

Aug. 12, 1947.

L. B. WAGNER

2,425,447

CONTROL STRUCTURE

Filed June 29, 1943

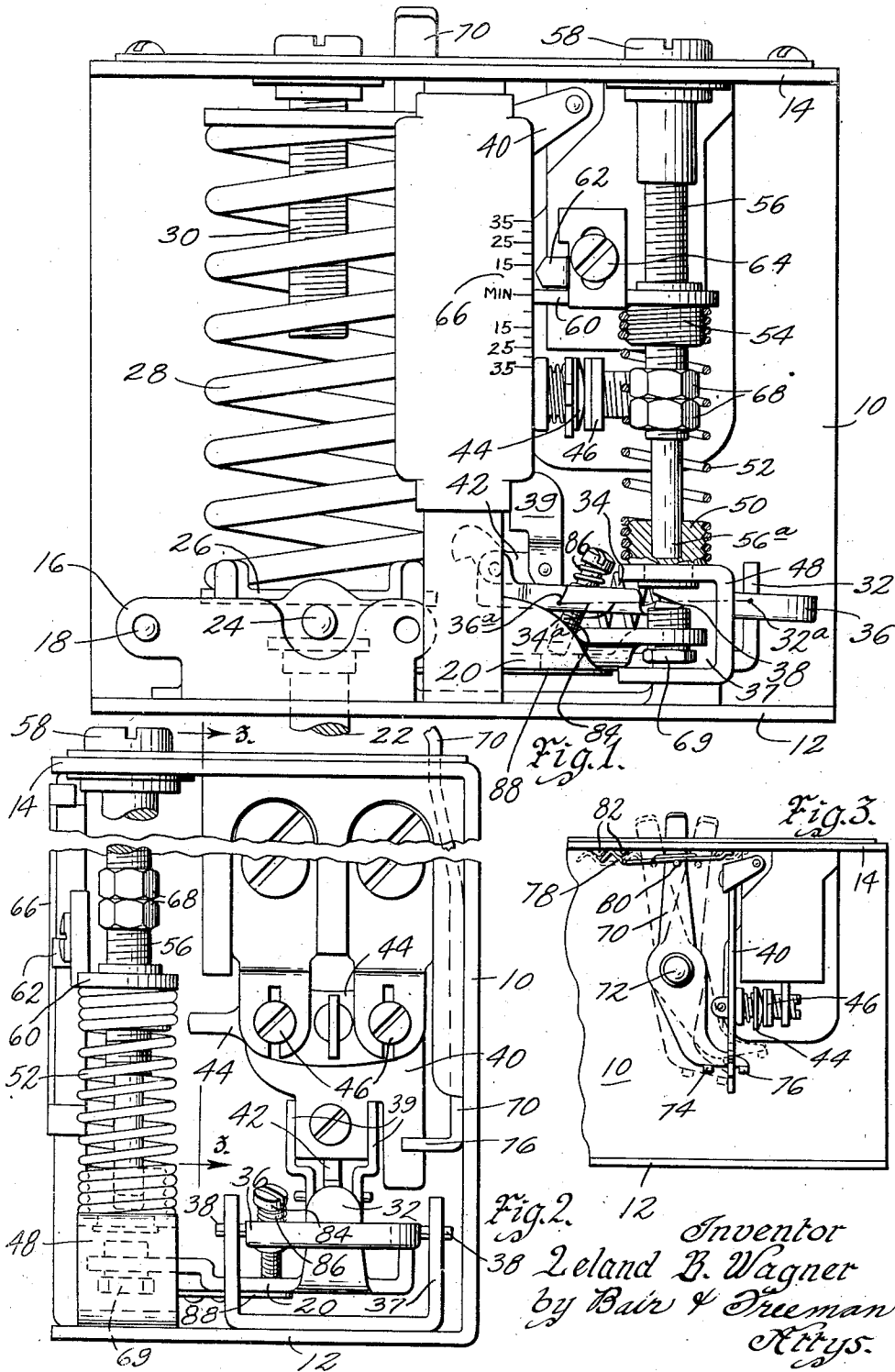

Fig. 1.
Fig. 2.
Fig. 3.
Inventor
Leland B. Wagner
by Bair & Freeman
Attys.

UNITED STATES PATENT OFFICE

2,425,447

CONTROL STRUCTURE

Leland B. Wagner, Goshen, Ind., assignor to Penn Electric Switch Co., Goshen, Ind., a corporation of Iowa

Application June 29, 1943, Serial No. 492,677

2 Claims. (Cl. 200—83)

1

My invention relates to a control structure such as an automatic electric switch having means for adjusting the differential thereof and operable to increase the differential in either a cut-out direction or a cut-in direction.

One object of the invention is to provide a single differential adjusting means, which may be arranged to oppose the movement of an actuating lever in either one direction or the opposite one, whereby a single switch can be carried in stock and adjusted for increase in differential in either one direction or the other, instead of it being necessary to have two different switches in stock, one with differential increase in one direction and the other with differential increase in the opposite direction.

Another object is to provide a differential widening means, which includes a yoke that can be adjusted for either pull or push of a spring relative thereto for causing the spring to oppose the movement of an actuating lever in either one direction or the other, and thereby increase the differential in the desired direction.

Still another object is to provide a lock means, which is associated with the differential adjusting means for insuring that it will be adjusted in only one range or the other as set by the dealer.

Still another object is to provide a means for manually controlling a switch or the like of a control structure, so that the switch can operate automatically or may be manually turned on or off as desired.

With these and other objects in view, my invention consists in the construction, arrangement, and combination of the various parts of my control structure, whereby the objects contemplated are attained, as hereinafter more fully set forth, pointed out in my claims, and illustrated in the accompanying drawings, in which:

Figure 1 is an enlarged front elevation of a control structure to which my differential widening means has been applied.

Figure 2 is an end elevation thereof, looking at the right-hand end of Figure 1; and

Figure 3 is a view similar to Figure 1 on a reduced scale, showing parts of the control structure removed in order to illustrate a manual switch of my control structure.

On the accompanying drawing, I have used the reference numeral 10 to indicate the back plate of a control housing, having a bottom plate 12 and a top plate 14. The cover of the housing is omitted from the drawing.

Within the housing, a bracket 16 supports a pivot pin 18 on which is pivoted an actuating

2

lever 20. The lever 20 is adapted to be actuated by a stem 22, which may be responsive to temperature or pressure changes, such as operable upon a bellows (not shown).

5 The stem 22 engages a cross pin 24 of the actuating lever 20 and also engaging this cross pin is a washer 26. A range spring 28 is seated on the washer 26 and is adjustable in the usual manner by means of an adjusting screw 30.

10 The lever 20 has an extension 32 connected by a spring 34 with a toggle lever 36. The lever 36 is pivoted at 38 to a bracket 37 by means of knife edges and V notches and is connected to a bracket 39 of a switch lever 40 by a toggle link 42. The center line for the spring 34 is indicated at 34a and its pivot points at 32a and 36a in Figure 1, the spring being of the toggle or over-center type.

20 The switch lever 40 carries a pair of movable bridging contacts 44 engageable with stationary contacts 46 when the switch is closed. The switch is automatically opened and closed with snap action by the actuating lever 20 through the over-center spring 34 and the toggle link 42. There is also an abutment connection between the actuating lever 20 and the toggle lever 36. This connection comprises an adjustable screw 84 having an adjustment retaining spring 86. The screw co-acts with a stiff leaf spring 88, the lever 20 having a hole therethru to permit passage of the screw.

30 My differential widening means consists of a yoke-like element 48 having a spring plug 50 secured thereto, and a differential spring 52 has its lower end threaded on the spring plug. The upper end of the differential spring is threaded on a second spring plug 54, in which is screw-threadedly mounted an adjusting stem 56. The stem 56 may be adjusted by means of a screw driver coacting with its slotted head 58.

40 The plug 54 has an extension 60 to which is secured a pointer 62 by means of a screw and slot connection 64 for the purpose of slight corrective adjustment at the factory. The pointer 62 is adapted to cooperate with a scale 66 for indicating the degree of differential widening.

45 On the adjusting stem 56, I provide a pair of lock nuts 68, which may be located either below the plug 54, as seen in Figure 1, or above the plug, as in Figure 2, depending on whether the differential is to be widened upon the lever 20 moving downwardly or upwardly. The lever 20 may be provided with an adjusting screw 69 for contact with the upper or lower arms of the yoke 48 as will hereinafter appear.

55 Also in my control structure, I provide a means

3

to manually control the switch or other control device to positively position it in the "off" or the "on" position as desired. This feature of the invention takes the form of a lever 70 (see Figure 3) pivoted to the wall 10 of the switch housing at 72. The lever 70 extends through the top 14 to the exterior of the switch housing for external operation and normally assumes the full line position shown in Figure 3. In such position, a pair of fingers 74 and 76 on the lever 70 permit free movement of the switch arm 40 to its opening and closed positions under automatic control of the actuating stem 22. When moved to the dotted position, however, the switch is continuously held "on" by the finger 74 and when moved to the dash line position it is continuously held "off" by the finger 76. In the "off" position, the leaf spring 88 permits the toggle lever 56 to be depressed even though the lever 20 may be held in raised position by pressure in the bellows 28.

For holding the lever 70 in any one of its three positions, a detent 78 is provided in the form of a leaf spring frictionally held against the top 14 of the switch housing by a pin 80 carried by the lever 70. The leaf spring detent is provided with an opening therethrough, fitting around the lever 70, so that it is moved toward the right or left, as the lever is moved. The detent cooperates with a pair of projections 82 on the bottom of the switch housing wall 14, so as to both indicate to the operator when he has fully moved the switch to one position or the other and to retain it there until it is again moved manually.

Practical operation

When the lock nuts 68 are below the plug 54, as seen in Figure 1, the switch is adjusted for widening the differential in a cut-out direction. As the adjusting screw 69 is moved downwardly, it will engage the lower arm of the yoke 48 and thereafter the tension of the spring 52 is imposed on the lever 20 to oppose its movement, thus widening the differential depending on how much tension there is in the spring 52. Normally with this adjustment, the spring holds the lower plug 50 against the bottom of an extension 56a of the stem 56, so that when the lever 20 moves downwardly, it will after some degree of movement engage the lower arm of the yoke and separate the bottom of the socket in the plug 50 from the lower end of the extension 56a. The scale 66 has a minimum mark (MIN) and the lock nuts 68 are positioned so that the pointer 62 has a range upward only from the minimum mark. This insures against any possibility of the differential being adjusted to the wrong direction in the field.

For widening the differential when the actuating lever 20 moves upwardly or in a cut-in direction, the lock nuts 68 may be arranged as in Figure 2, and the pointer 62 will travel between MIN and the indicating numerals on the scale 66 below the minimum mark. In this case, the plug 50 is forced downwardly by compression of the spring 52, so that the yoke-like element 48 rests on the bottom 12 and the lever 20 and its

4

screw 68 when moving upwardly will engage the upper arm of the yoke and compress the spring instead of extending it. The differential of operation is thereby increased in the reverse direction with respect to Figure 1, and the degree of such increase can, of course, be varied by the adjusting stem 56, as indicated by the pointer 62 cooperating with the scale 66 below the minimum mark.

From the foregoing, it will be obvious that I have provided a differential widening means, which may be set for increasing the differential in either a cut-in or a cut-out direction on a control switch, or in either direction with respect to any type of actuating lever or the like. The device, of course, is adaptable to any type of control device and is not limited necessarily to automatic switches.

Some changes may be made in the arrangement and construction of the various parts of my control structure, without departing from the real spirit and purpose of my invention, and it is my intention to cover by my claims, any modified forms of structure or use of mechanical equivalents, which may be reasonably included within their scope.

I claim as my invention:

1. In a control structure, an actuating lever having a range of movement, a spring, an adjustable anchorage for one end of said spring, a yoke carried by the other end of said spring, a portion of said actuating lever being positioned in said yoke and of less thickness than the distance between its sides, a pair of limit stops for said yoke in opposite directions, said anchorage being adjustable to cause said spring to either pull said yoke against one of said stops whereby said actuating lever may engage one side of the yoke and move it away from said stop, or push said yoke against the other of said stops whereby said actuating lever may engage the other side of said yoke and move it away from said last stop.

2. In a control structure, an actuating lever having a range of movement, a yoke having arms on opposite sides of said lever, a sleeve secured to said yoke, an adjusting screw having a guide portion in said sleeve, said yoke at one limit of movement being stopped by said guide portion, a stop for said yoke in the opposite direction permitting limited sliding movement of said sleeve on said guide portion, an adjusting nut threaded on said adjusting screw, and a spring connection between said adjusting nut and said sleeve.

LELAND B. WAGNER.

REFERENCES CITED

The following references are of record in the file of this patent:

| UNITED STATES PATENTS | | |
|-----------------------|---------|----------------|
| Number | Name | Date |
| 1,969,304 | Grooms | Aug. 7, 1934 |
| 2,054,328 | King | Sept. 15, 1936 |
| 2,131,282 | Henning | Sept. 27, 1938 |
| 1,969,326 | Raney | Aug. 7, 1934 |
| 2,291,501 | Persons | July 28, 1942 |
| 2,298,795 | Judson | Oct. 13, 1942 |