

(No Model.)

C. N. HAMMOND.
ROSETTE FOR ELECTRIC LIGHT WIRES.

No. 525,653.

Patented Sept. 4, 1894.

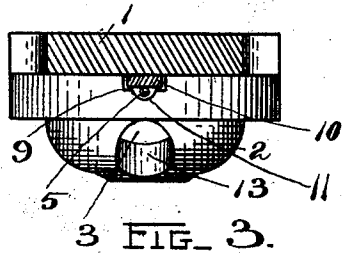
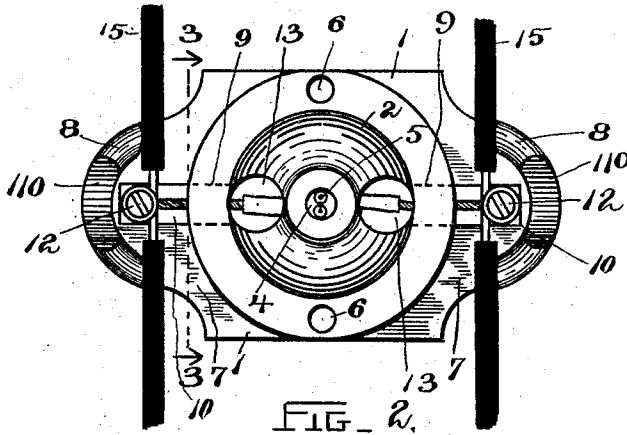
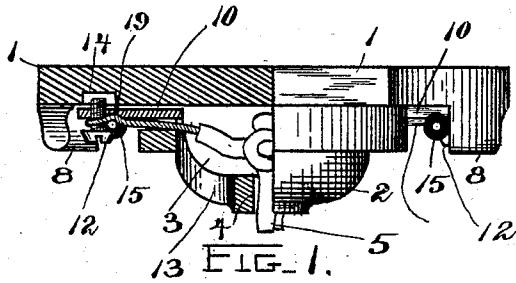

WITNESSES

Harry M. Key.
Arthur F. Randall.

INVENTOR

Chas. N. Hammond
by Macleod Balver & Randall
his Attorneys.

UNITED STATES PATENT OFFICE.

CHARLES N. HAMMOND, OF BOSTON, MASSACHUSETTS.

ROSETTE FOR ELECTRIC-LIGHT WIRES.

SPECIFICATION forming part of Letters Patent No. 525,653, dated September 4, 1894.

Application filed January 15, 1894. Serial No. 496,876. (No model.)

To all whom it may concern:

Be it known that I, CHARLES N. HAMMOND, a citizen of the United States, residing at Boston, in the county of Suffolk and State of Massachusetts, have invented certain new and useful Improvements in Rosettes for Electric-Light Wires, of which the following is a specification, reference being had therein to the accompanying drawings.

My invention relates to the rosettes, so called, which are used in connection with suspended incandescent electric lights. They provide for the connection of the lamp-cords, by means of which the electric lights are hung or suspended, with the main-feed-wires which supply the electric current; and, in addition, serve for the support of the said feed-wires and lamp-cords, the said rosettes being secured in suitable manner to a ceiling or other support. They are employed, also, for other similar uses.

The object of my invention is to provide a rosette of high efficiency, affording perfect security from fire, and of simple and inexpensive but durable character and construction, the parts of which may be conveniently assembled, and which shall admit of having the lamp-cords and feed wires applied thereto and connected with each other quickly and conveniently.

In the drawings, Figure 1 is a view of a rosette embodying my invention in the best form which has yet been devised by me, it representing one-half of the rosette in elevation and the other half thereof in vertical section, and showing the lamp cord and feed wires applied thereto. Fig. 2 is a view of the parts which are represented in Fig. 1, it showing them in inverted plan and representing the entire rosette. Fig. 3 is a view in section on the line 3-3 of Fig. 2, looking toward the right-hand side in latter figure.

The rosette shown in the drawings is formed of some suitable non-conducting material. The body thereof comprises a back or base portion 1, and a bulb or boss 2 having an internal chamber 3, the said parts being made integral or solid with each other, and a hole 4 being made centrally through the face of the bulb or boss and opening into the said chamber 3, the said hole serving for the passage of the lamp cord 5. The back or base

portion 1 is made solid or continuous and closes the said chamber on the side which is next the support to which the rosette is applied when in use. Holes 6, 6 are formed through the body at the opposite edges thereof, for the passage of the screws or other fastening devices which are employed to secure the rosette in place upon the ceiling or other support to which it is applied. At opposite sides of the bulb or boss 2 the back or base portion 1 has lateral extensions or ears 7, 7, from the outer edges of which extend at right angles the guard flanges 8, 8. The portion of the bulb or boss 2 which joins the back or base 1 has formed therethrough on the sides thereof which are adjacent to the flanges 8, 8, the horizontal slots 9, 9, for the reception of metal strips 10, 10 the said slots perforating the said sides as shown in Figs. 1 and 3.

The strips 10, 10 fit the slots 9, 9, so as thereby to be held in place in the rosette, although they are capable of endwise movement therethrough such as enables them to be applied or removed. Communicating with each slot 9 is the groove 11 through which is passed the bared end of one of the strands of the lamp cord. The outer end of each strip 10 has a threaded hole therethrough for the reception of the stem of a binder screw 12. Through the face of the bulb or boss 2, holes 13, 13 are formed on opposite sides of the central hole 4, these holes 13, 13 opening also into the internal chamber 3. At 14 is a hole or recess in the back or base 1, into which the end of the binder-screw projects, the said end fitting loosely in the said hole or recess and having free play therein.

In applying the strips 10, 10 to the body of the rosette, when assembling the parts, the strips are simply slipped endwise into the slots 9, 9, the cut-away places 11 of the flanges 8, 8, permitting the application of the strips in the manner stated. After the strips have been thus slipped into place, the binder-screws 12, 12 are applied to the outer ends thereof, the inner ends of the screws projecting into holes or recesses 14 in the back or base portion and, although they fit and play loosely in said holes or recesses, operating to prevent the withdrawal of the strips.

The holes 13, 13 on opposite sides of the central hole 4 permit the manipulation of the

strands of the lamp-cord as required in applying the rosette to use. The ends of the said strands of lamp-cord first are passed from the outside through the hole 4 into the chamber 3, and then both are withdrawn to the outside again through one of the side holes 13. The said ends are then knotted together in the customary manner, and are then re-introduced by means of the same hole 13, into the interior chamber 3, the bared ends thereof next being respectively pushed out through the opposite grooves 11 and applied to the stems of the binding screws 12, 12, the two holes 13, 13 serving to enable the said ends conveniently to be passed through the respective grooves, by the person engaged in making the connections. Then the bared portions of the feed wires 15, 15 having been laid against the said bared ends of the lamp cord strands, under the heads of the binding screws 12, 12, the said screws are turned in so as to clamp the whole together between the heads thereof and the strips 10. A depression is formed in the surface of each strip 10 adjacent to the binder-screw 12, as at 19, in Fig. 1, and the pressure of the head of the binder-screw upon the feed-wire causes the under-lying portion of lamp-cord strand to be bent into this depression, thus enabling the feed wires to be held more securely in position.

The object of using the strips 10 is to dispense with the formation of threaded holes in the body of the rosette, and simplify the operations by which the said body is produced, thereby cheapening the cost of the rosette. Moreover, when the body of the rosette is made of porcelain or the like, it is practically impossible to form therein screw-threaded holes such as would be required for the reception of binder-screws if the latter were to be screwed into the body of the rosette.

Instead of screwing the binder-screws 12 into the body of the rosette, I screw them into the strips 10, the holes in the latter being threaded for the reception of the threaded stems of the screws. The strips 10 are themselves held in place in the body of the rosette in a simple and convenient manner without the employment of any separate securing device, thereby rendering unnecessary the use of screws passing through the same and into the body of the rosette.

An important result secured by the rosette, constructed as shown in the drawings with a

solid back extending continuously across and closing the chamber which is formed within the body of the rosette, is that thereby complete protection is afforded to the support to which the rosette is applied.

What I claim is—

1. A rosette having an internal chamber, a back or base extending continuously across and closing the said chamber, a central hole through which the lamp-cord passes to the said internal chamber, side-holes perforating the sides of the rosette and through which the ends of the lamp-cord may extend for connection with the feed-wires, strips loosely fitting the said side-holes, and binders applied to the outer ends of said strips and entering loosely cavities in the body of the rosette to check endwise movement of the strips in the said holes, substantially as described.

2. A rosette having an internal chamber, a back or base extending continuously across and closing the said chamber, a central hole through which the lamp-cord passes to the said internal chamber, side-holes through which the ends of the lamp-cord strands may extend for connection with the feed-wires, one or more holes or openings 13, 13 adjacent to the said central hole and through which the knotted ends of the lamp cord strands may be passed and whereby the manipulation of the said ends in knotting the lamp-cord and passing the ends of the strands thereof out through the side holes is permitted, and binders, substantially as described.

3. A rosette having an internal chamber, a back or base extending continuously across and closing the said chamber, holes 14, 14 in said back or base, a central hole through which the lamp-cord passes to the said internal chamber, slots 9, 9, in the sides thereof, strips 10, 10 fitting the said slots, and binder screws 12, 12 passing through the outer ends of the strips and having their points or inner ends passing loosely into the holes 14, 14, in the back or base, the said screws serving both to bind the ends of the lamp-cord strands to the feed wires and to prevent the withdrawal of the strips, substantially as described.

In testimony whereof I affix my signature in presence of two witnesses.

CHARLES N. HAMMOND.

Witnesses:

WM. A. MACLEOD,
CHAS. F. RANDALL.