



US 20140123448A1

(19) **United States**

(12) **Patent Application Publication**  
**Tussy**

(10) **Pub. No.: US 2014/0123448 A1**

(43) **Pub. Date: May 8, 2014**

(54) **STRAP LENGTH ADJUSTER FOR SANDALS**

(52) **U.S. Cl.**

(71) Applicant: **Kevin Alan Tussy**, Las Vegas, NV (US)

CPC ..... *A43C 11/165* (2013.01)

USPC ..... **24/68 SK**

(72) Inventor: **Kevin Alan Tussy**, Las Vegas, NV (US)

(57) **ABSTRACT**

(21) Appl. No.: **13/669,746**

(22) Filed: **Nov. 6, 2012**

**Publication Classification**

A system for adjusting the length of a sandal strap comprising a receiving member attached to a sandal strap at or near the end of the sandal strap, a tightening member that extends up into the hole through the sole of the sandal to engage the receiving member, wherein the length of the sandal strap can be adjusted by actuating the tightening member.

(51) **Int. Cl.**  
*A43C 11/16* (2006.01)

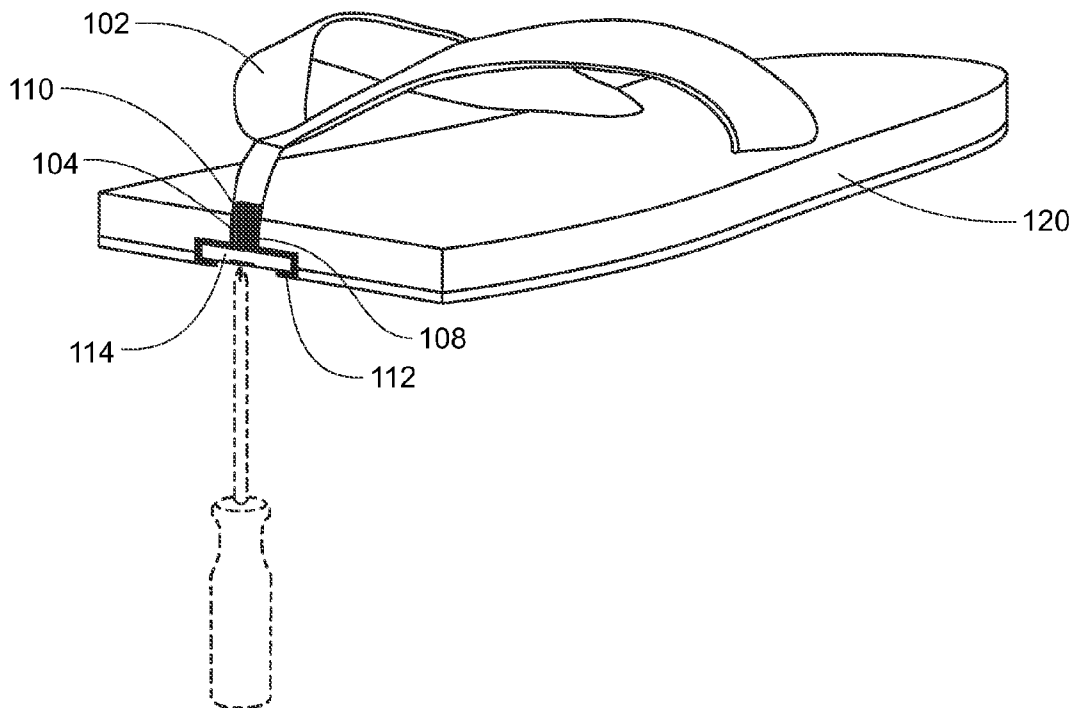

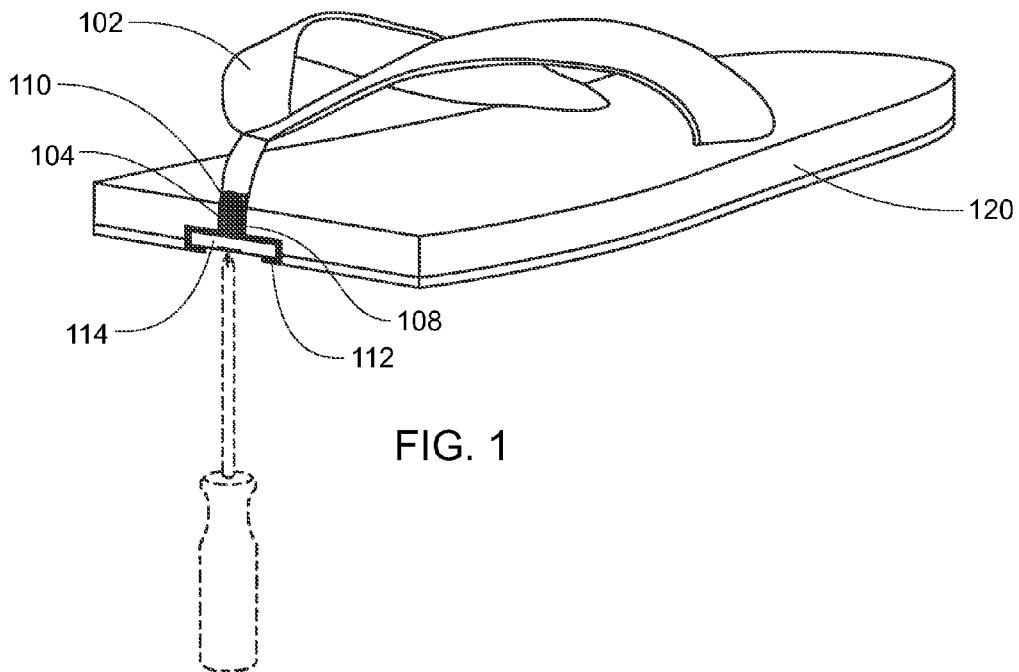

FIG. 1

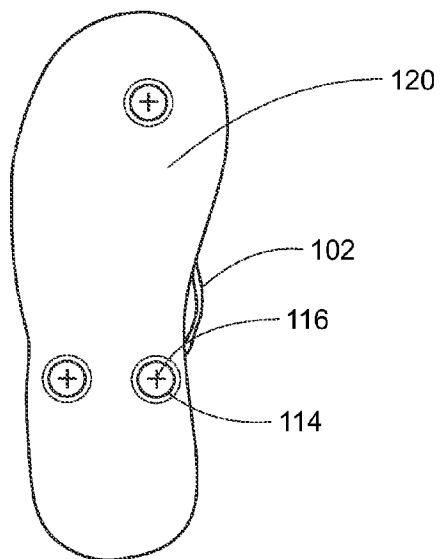

FIG. 2

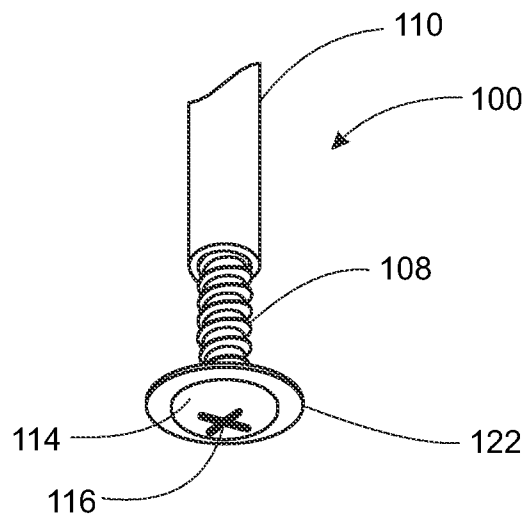

FIG. 4

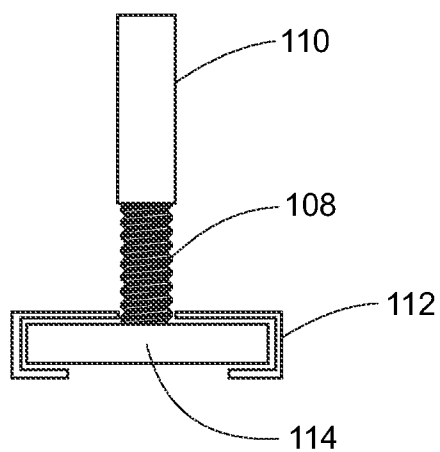

FIG. 6

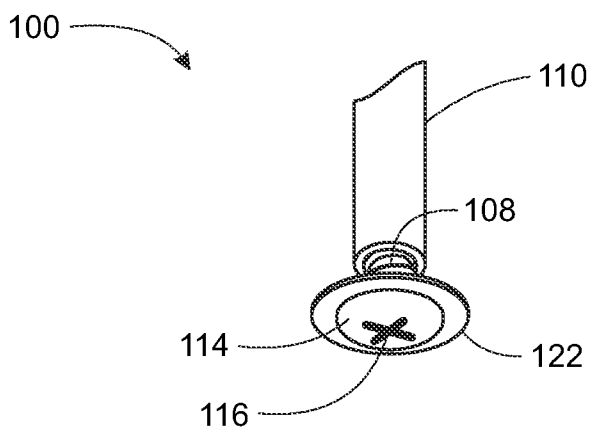

FIG. 3

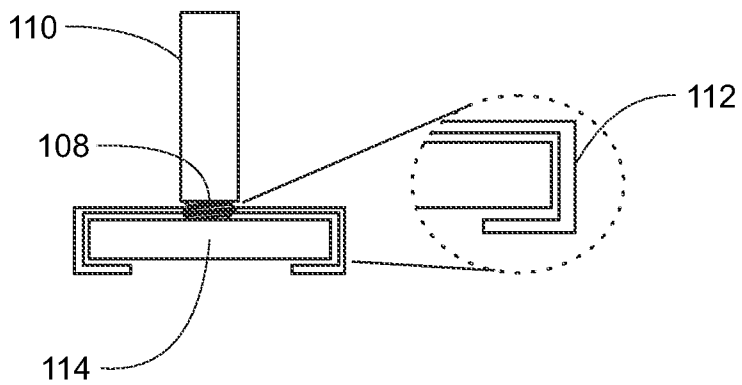

FIG. 5

**STRAP LENGTH ADJUSTER FOR SANDALS**

**BACKGROUND OF THE INVENTION**

**[0001]** 1. Field of the Invention

**[0002]** The invention relates generally to the field of sandals. In particular, the invention relates to sandal straps that can be shortened or lengthened to create the perfect fit for the wearer.

**[0003]** 2. Description of Related Art

**[0004]** The prior art includes a wide range of strap types for sandals including “flip-flop” sandals that typically have a strap that extends up between the big toe and the second toe, then splits into two straps that extend back across respective sides of the wearer’s foot. In perhaps the most common configuration of the flip-flop, the ends of the straps extend through holes in the sole of the sandal and are held in place by a flat disk or plug larger than the hole so that the strap end cannot pull through.

**[0005]** Prior art devices have failed to effectively provide any means to adjust the length of the straps on sandals like flip-flops to provide a custom fit for the wearer and to adjust the straps to account for stretching and wear. The present invention provides a simple, effective solution that allows the user to easily adjust the fit of their sandals to create a perfect fit for their foot height and width.

**SUMMARY OF THE INVENTION**

**[0006]** A system for adjusting the length of a sandal strap comprising a receiving member attached to a sandal strap at or near the end of the sandal strap, a tightening member that extends up into the hole through the sole of the sandal to engage the receiving member, wherein the length of the sandal strap can be adjusted by actuating the tightening member. In various exemplary embodiments, the receiving member is attached to the sandal strap by an adhesive and/or the receiving member and tightening members are threaded. In various exemplary embodiments, the threads of the tightening member engage the threads of the receiving member to shorten or lengthen the strap when the tightening member is rotated. In various exemplary embodiments, the tightening member has a head that is larger in diameter than the hole through the sole of the sandal. In various exemplary embodiments, the head comprises one or more slots that may be engaged to rotate the tightening member. In various exemplary embodiments, the back side of the head comprises a locking structure to prevent the tightening member from unintentional rotation. In various exemplary embodiments, a plastic or metal washer is molded into the sole of the footwear. In various exemplary embodiments, the tightening member is recessed into the sole of the sandal. In various exemplary embodiments, the tightening member is at least partially enclosed in a housing. In various exemplary embodiments, three tightening mechanisms are configured in the sole of a sandal to allow for adjustment between the big and second toe, and on either side of the foot.

**BRIEF DESCRIPTION OF THE DRAWINGS**

**[0007]** FIG. 1 is a diagram showing a cut-away view of a sandal with an exemplary embodiment of a strap-length adjuster.

**[0008]** FIG. 2 is a diagram showing a bottom view of a sandal with an exemplary embodiment of a strap-length adjuster.

**[0009]** FIG. 3 is a diagram showing a perspective view of an exemplary embodiment of a strap-length adjuster.

**[0010]** FIG. 4 is a diagram showing a side view of an exemplary embodiment of a strap-length adjuster.

**[0011]** FIG. 5 is a diagram showing a perspective view of an exemplary embodiment of a strap-length adjuster.

**[0012]** FIG. 6 is a diagram showing a side view of an exemplary embodiment of a strap-length adjuster.

**DETAILED DESCRIPTION OF THE PREFERRED EMBODIMENTS**

**[0013]** The following description is presented to enable any person skilled in the art to make and use the invention. For purposes of explanation, specific nomenclature is set forth to provide a thorough understanding of the present invention. Descriptions of specific embodiments or applications are provided only as examples. Various modifications to the embodiments will be readily apparent to those skilled in the art, and general principles defined herein may be applied to other embodiments and applications without departing from the spirit and scope of the invention. Thus, the present invention is not intended to be limited to the embodiments shown, but is to be accorded the widest possible scope consistent with the principles and features disclosed herein. Moreover, while the present invention is discussed herein primarily with respect to flip-flop sandals, it will be understood that the present invention can be used with other types of footwear, including all types of sandals.

**[0014]** Referring to FIGS. 1 through 6, in various embodiments the present invention comprises a sandal strap 102 with one or more strap ends 104 that extend up to or through one or more holes in the sole of the sandal. The strap ends 104 are prevented from pulling back through holes in the sole 120 of the sandal by an adjustable securing mechanism 100.

**[0015]** In various exemplary embodiments, the adjustable securing mechanism 100 may comprise a tightening member 108, and a receiving member 110 secured to the sandal strap end 104. The tightening member 108 may include threads that mate with compatible threads in the receiving member 110. The head 114 of the tightening member 108 may further have one or more slots 116 that may be actuated by a screwdriver, a coin, or any other suitably shaped object to rotate the tightening member 108, or by any other suitable recess, head shape, or flange that allows a user to rotate the tightening member 108. As the head 114 rotates, the threads of tightening member 108 move the tightening member 108 deeper into the receiving member 110, reducing the overall length of that portion of the strap 102. The head 114 can be turned the opposite direction to increase the strap length and loosen the fit for the wearer.

**[0016]** In various exemplary embodiments of the invention, one or more threaded receiving members 110 are fastened to one or more of the ends 104 of the sandal straps such that the threaded receiving members 110 are generally located within a hole through the sole 116 of the sandal.

**[0017]** Referring to FIGS. 3 and 4, the tightening member 108 may comprise a threaded screw or bolt. The head 114 of the tightening member may be configured in a size or shape that prevents it from passing through the hole in the sole, or the tightening member 108 may be equipped with a washer 122 or similar device.

**[0018]** Referring to FIGS. 5 and 6, the head 114 of the tightening member 110 may be surrounded by cover 112 recessed or molded into the sole 120 of the sandal. The cover

112 may be made of plastic, rubber, metal, or any other suitable material, and may have a cover or an access opening to access the head 114 for adjustment and to ensure that the tightening member 108 is protected from the ground while walking. The back sides of the head 114 may feature ribs or another locking structure to create friction between the screw head and the sandal or cover 112 to prevent the tightening member from loosening unintentionally.

[0019] In various exemplary embodiments, the invention comprises three tightening mechanisms configured in the sole of a flip-flop type of sandal to allow adjustment in between the big toe and second toe and on either side of the foot.

[0020] It will be readily understood that a wide range of tightening mechanisms 108 in addition to threaded devices like screws or nuts can be used to create the adjustable straps disclosed herein. In the present disclosure, various devices are described and set forth with regard to several embodiments. It is contemplated that features of the disclosed embodiments may be combined in any manner as may be desired for various applications and implementations.

What is claimed is:

- 1. A system for adjusting the length of a sandal strap comprising:
  - a receiving member attached to a sandal strap at or near the end of the sandal strap;
  - a tightening member that extends up into the hole through the sole of the sandal to engage the receiving member;
 wherein the length of the sandal strap can be adjusted by actuating the tightening member.

2. The system of claim 1, wherein the receiving member is attached to the sandal strap by an adhesive.

3. The system of claim 1, wherein the receiving member is threaded.

4. The system of claim 3, wherein the tightening member is threaded.

5. The system of claim 4, wherein the threads of the tightening member engage the threads of the receiving member to shorten or lengthen the strap when the tightening member is rotated.

4. The system of claim 1, wherein the tightening member has a head that is larger in diameter than the hole through the sole of the sandal.

5. The system of claim 1, wherein the head comprises one or more slots that may be engaged to rotate the tightening member.

6. The system of claim 1, wherein the back side of the head comprises a locking structure to prevent the tightening member from unintentional rotation.

7. The system of claim 1, wherein a plastic or metal washer is molded into the sole of the footwear.

8. The system of claim 1, wherein the tightening member is recessed into the sole of the sandal.

9. The system of claim 1, wherein the tightening member is at least partially enclosed in a housing.

10. The system of claim 1, wherein three tightening mechanisms are configured in the sole of a sandal to allow for adjustment between the big and second toe, and on either side of the foot.

\* \* \* \* \*