

June 15, 1937.

H. PAXTON ET AL

2,084,048

AUTOMATIC LID NAILING MACHINE

Filed Sept. 5, 1933

11 Sheets-Sheet 1

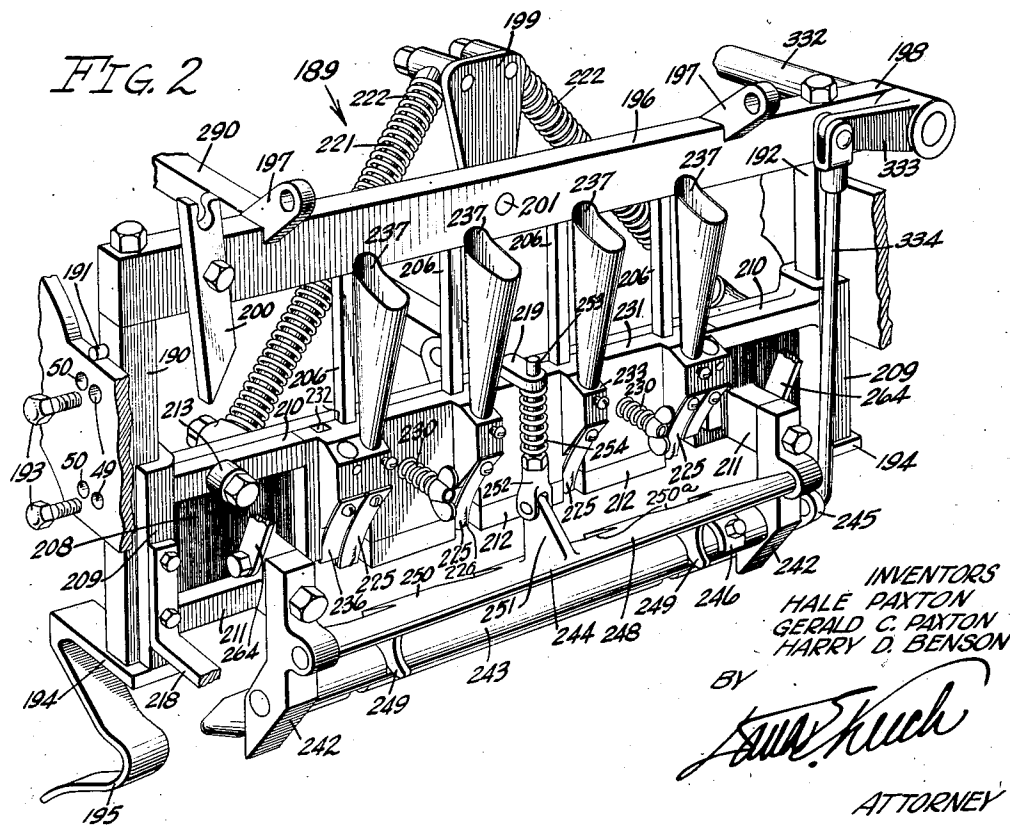
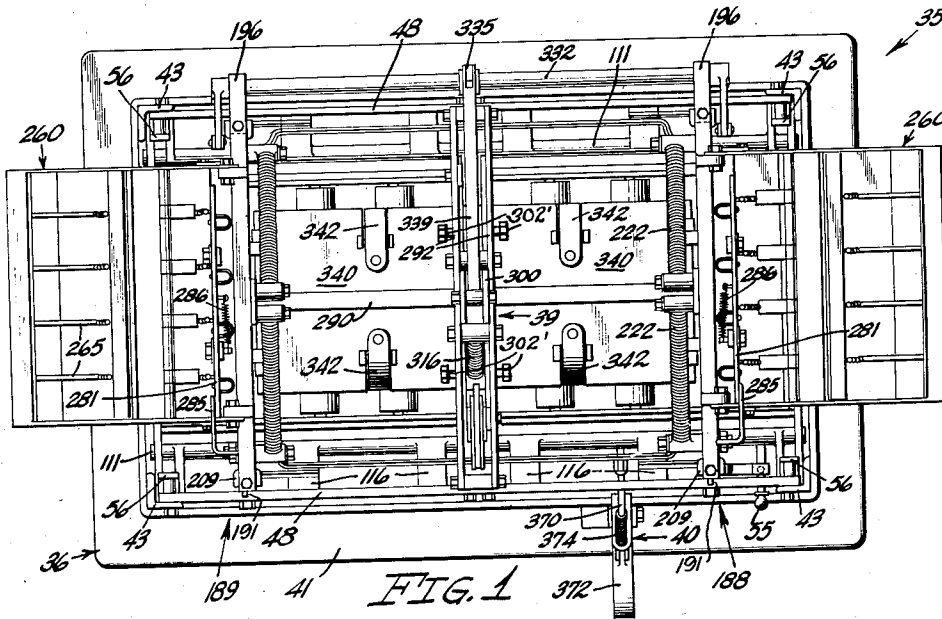

INVENTORS
HALE PAXTON
GERALD C. PAXTON
HARRY D. BENSON

BY
Samuel Keuch
ATTORNEY

June 15, 1937.

H. PAXTON ET AL

2,084,048

AUTOMATIC LID NAILING MACHINE

Filed Sept. 5, 1933

11 Sheets-Sheet 2

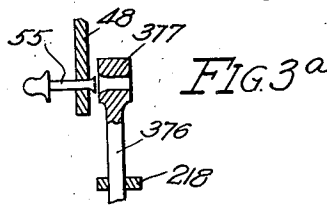
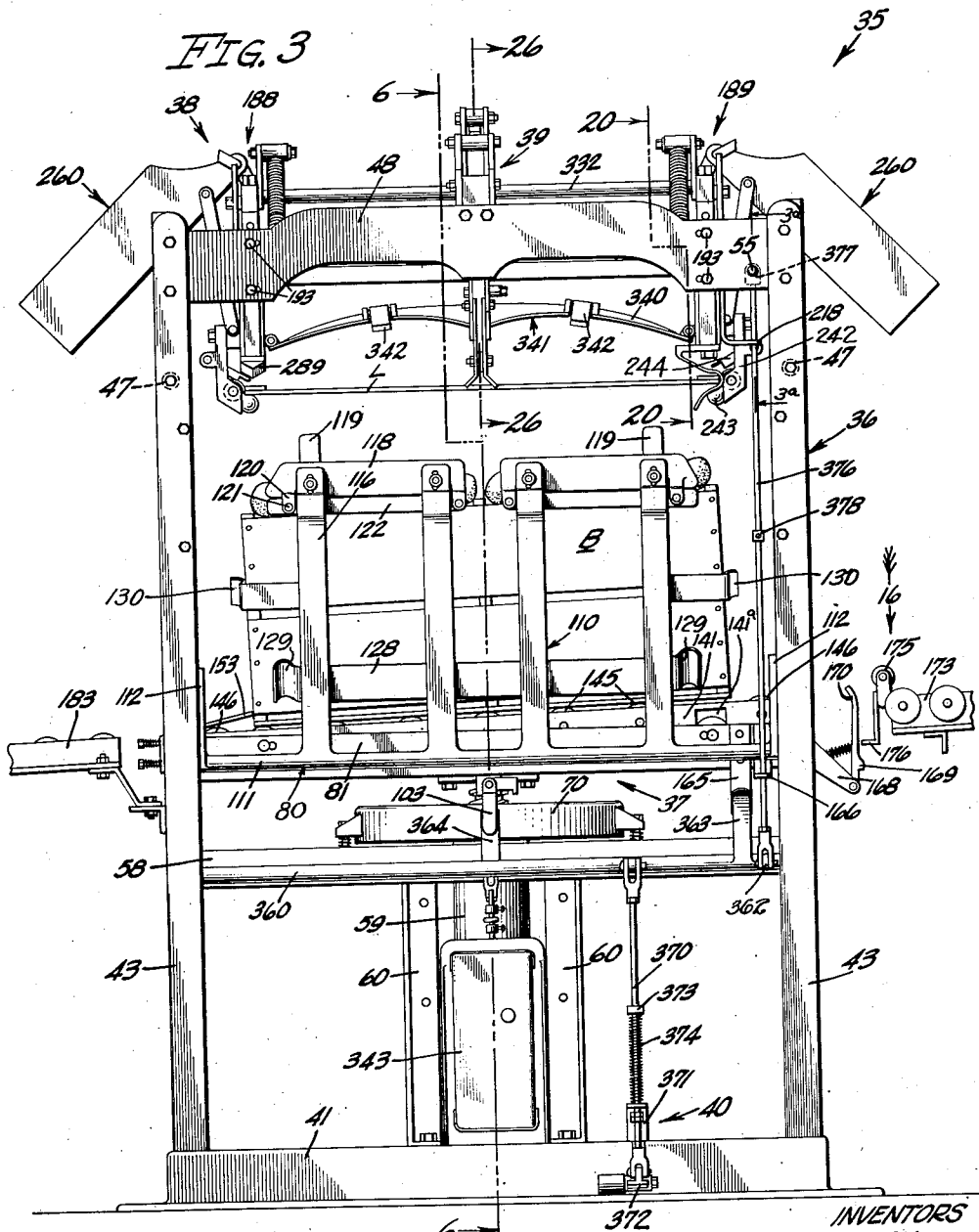

INVENTORS
 HALE PAXTON
 GERALD C. PAXTON
 HARRY D. BENSON
 BY

John Keck

ATTORNEY

June 15, 1937.

H. PAXTON ET AL
AUTOMATIC LID NAILING MACHINE

2,084,048

Filed Sept. 5, 1933

11 Sheets-Sheet 3

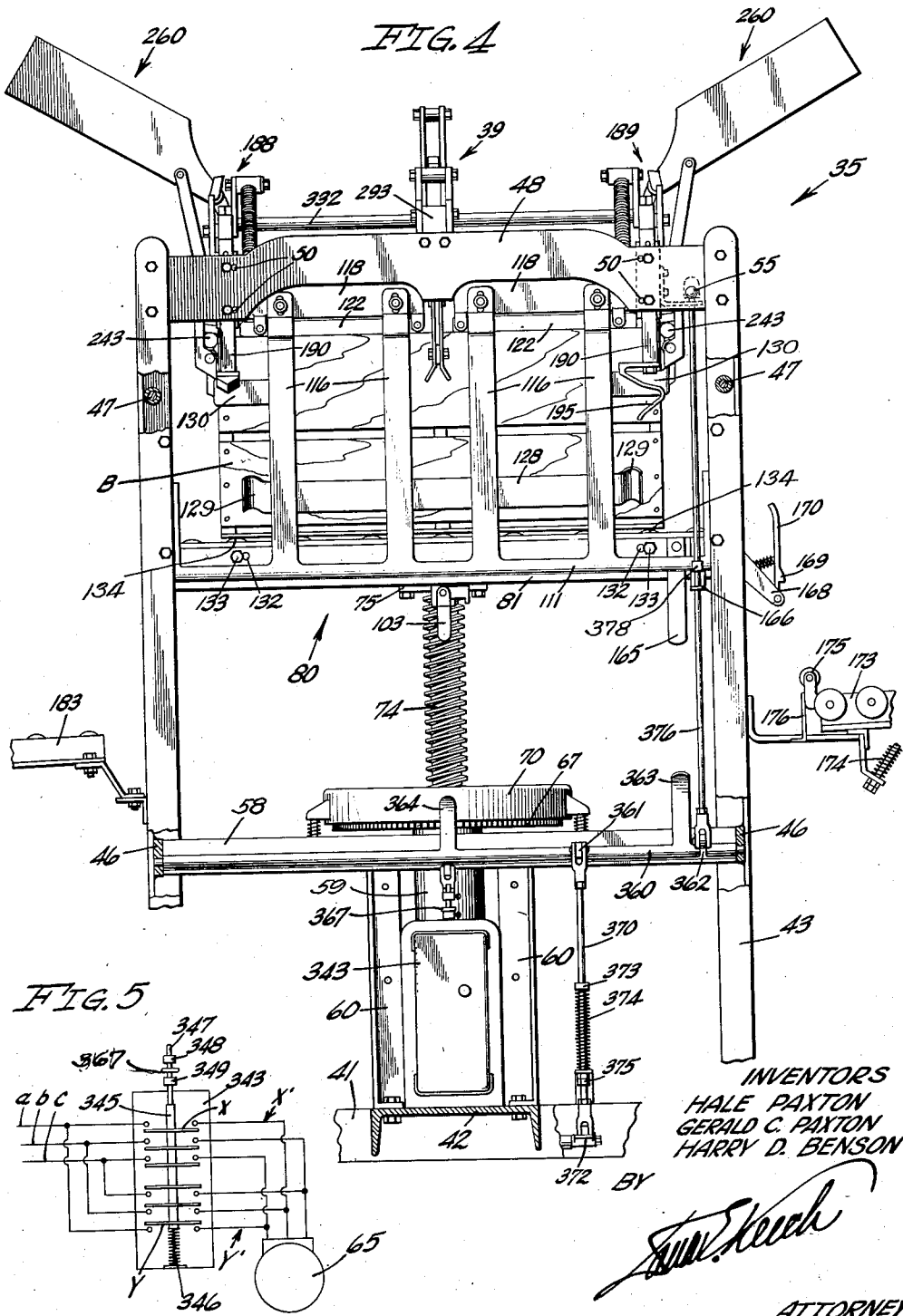

INVENTORS
HALE PAXTON
GERALD C. PAXTON
HARRY D. BENSON

BY *[Signature]*

ATTORNEY

June 15, 1937.

H. PAXTON ET AL

2,084,048

AUTOMATIC LID NAILING MACHINE

Filed Sept. 5, 1933

11 Sheets-Sheet 4

FIG. 6

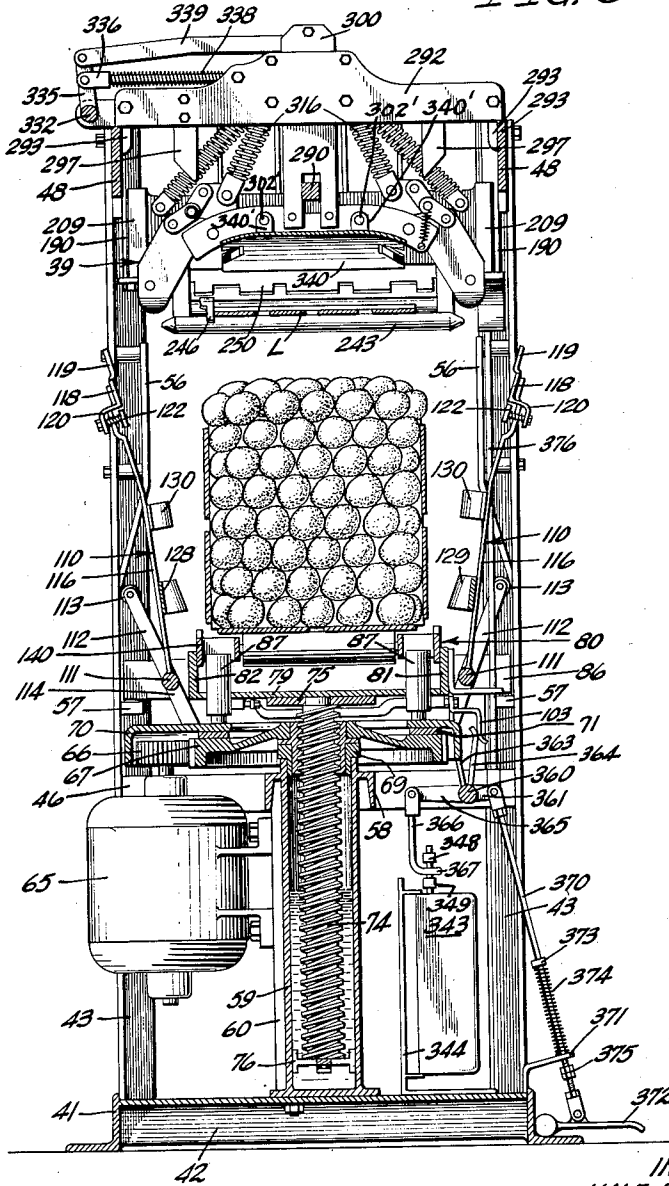

INVENTORS
HALE PAXTON
GERALD C. PAXTON
HARRY D. BENSON

BY

ATTORNEY

June 15, 1937.

H. PAXTON ET AL

2,084,048

AUTOMATIC LID NAILING MACHINE

Filed Sept. 5, 1933

11 Sheets-Sheet 5

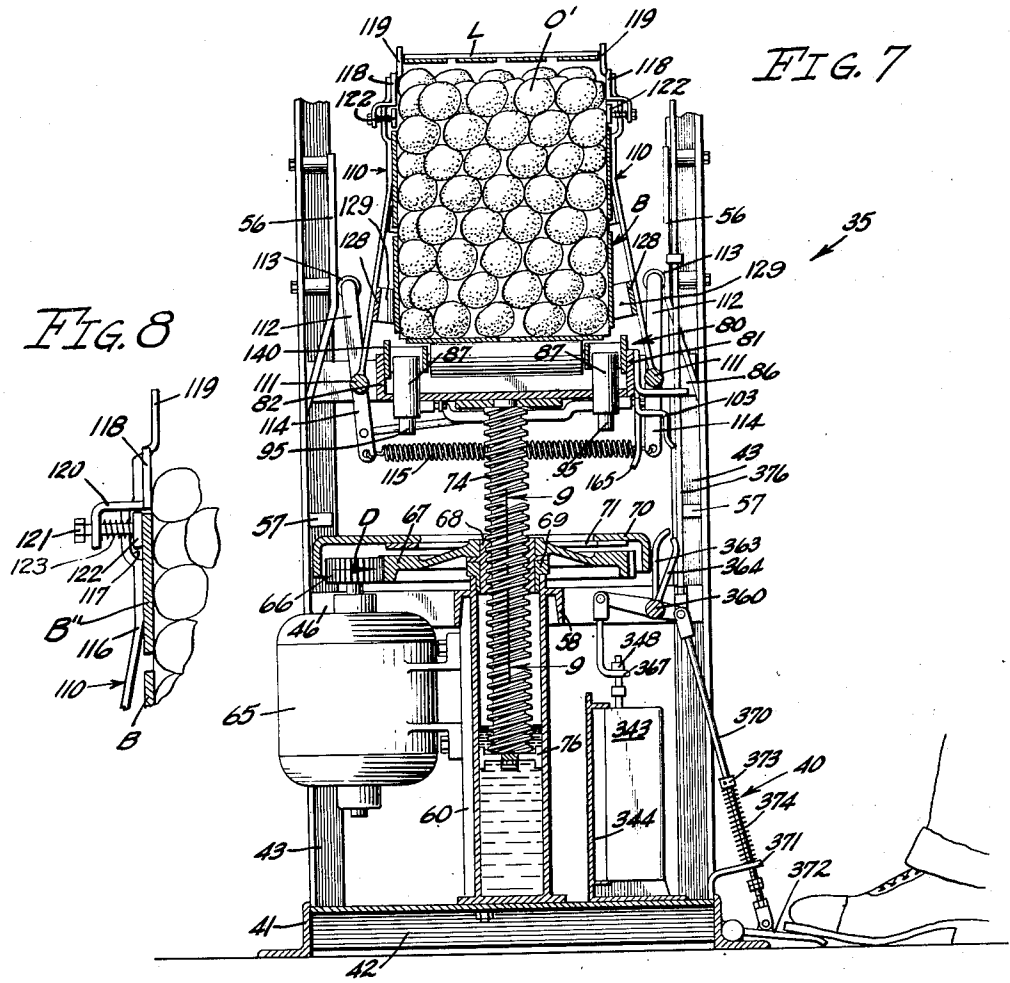

FIG. 8

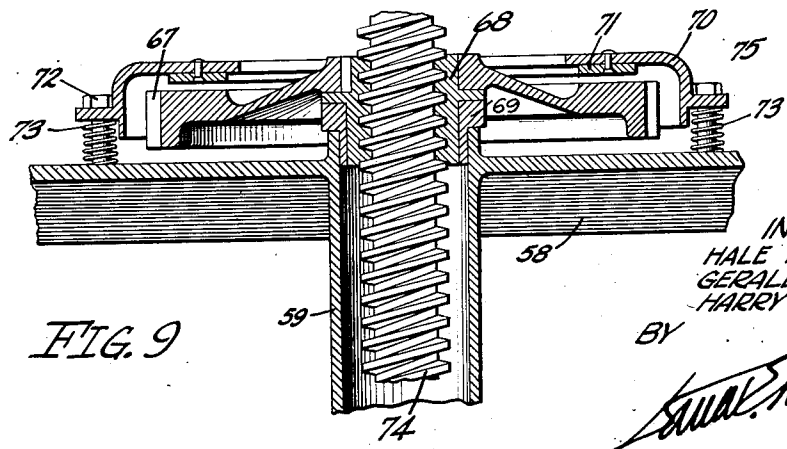
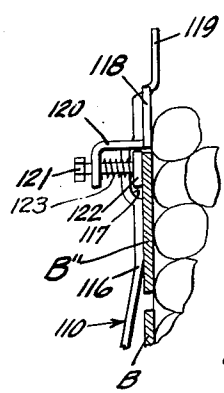

FIG. 9

FIG. 7

INVENTORS
HALE PAXTON
GERALD C. PAXTON
HARRY D. BENSON

BY
Paul. Kitch
ATTORNEY

June 15, 1937.

H. PAXTON ET AL

2,084,048

AUTOMATIC LID NAILING MACHINE

Filed Sept. 5, 1933

11 Sheets-Sheet 6

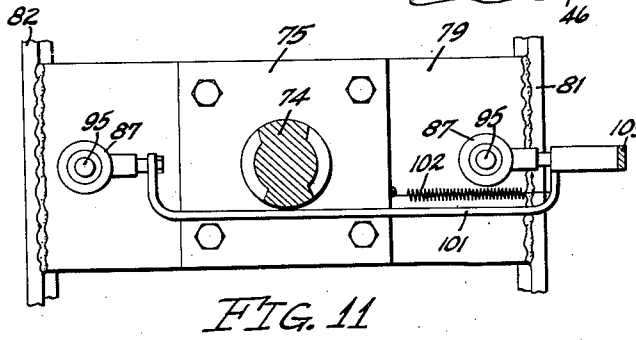
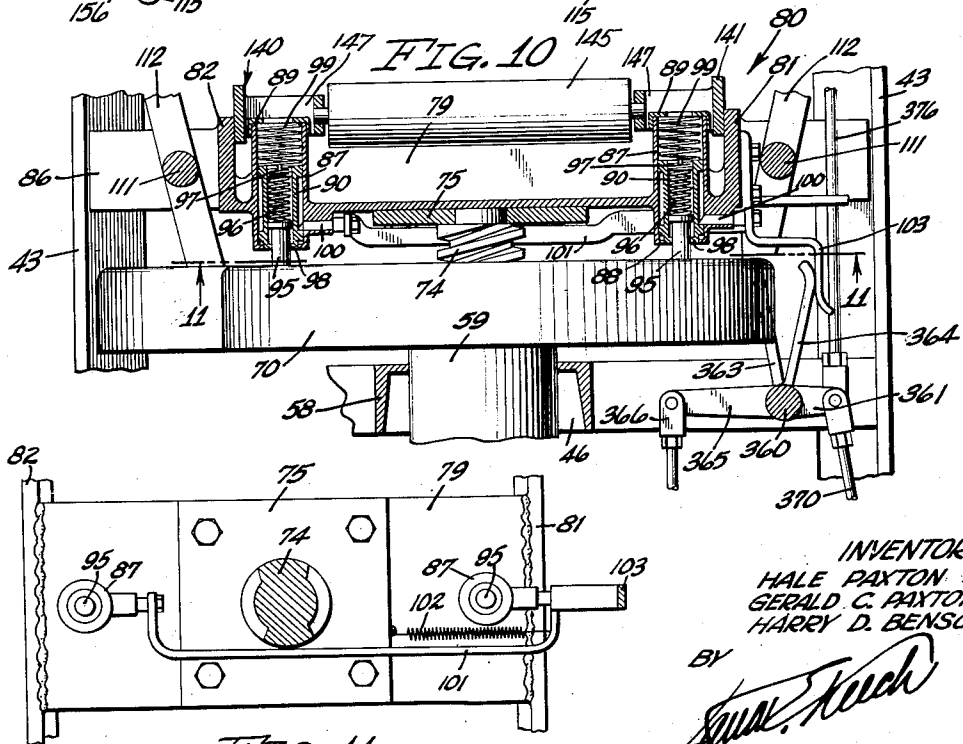
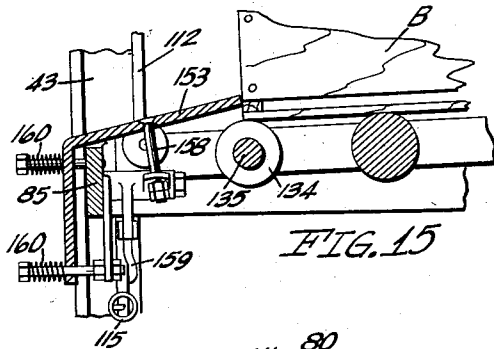
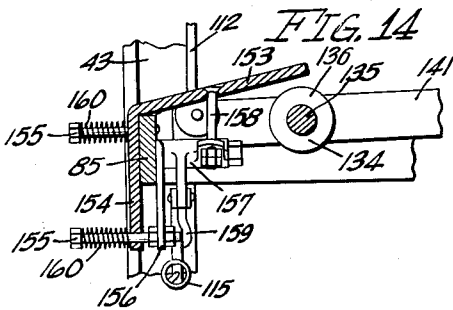
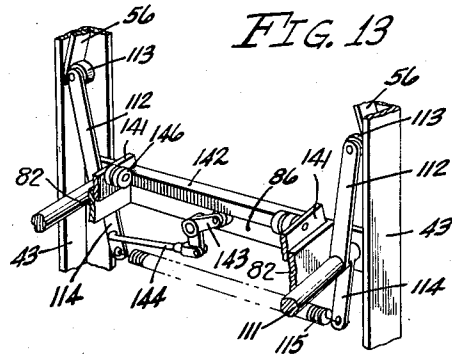
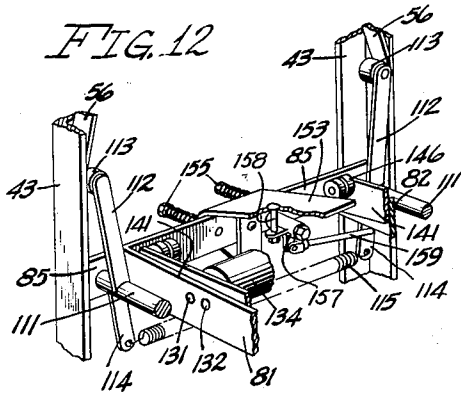

INVENTORS
HALE PAXTON
GERALD C. PAXTON
HARRY D. BENSON

BY *Paul Keck*

ATTORNEY

June 15, 1937.

H. PAXTON ET AL

2,084,048

AUTOMATIC LID NAILING MACHINE

Filed Sept. 5, 1935

11 Sheets-Sheet 7

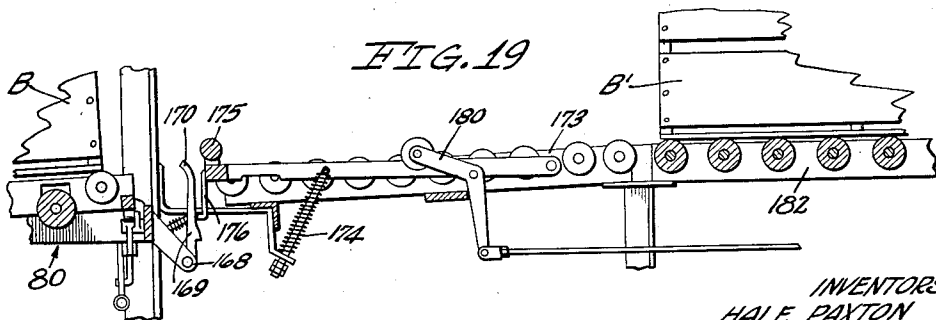
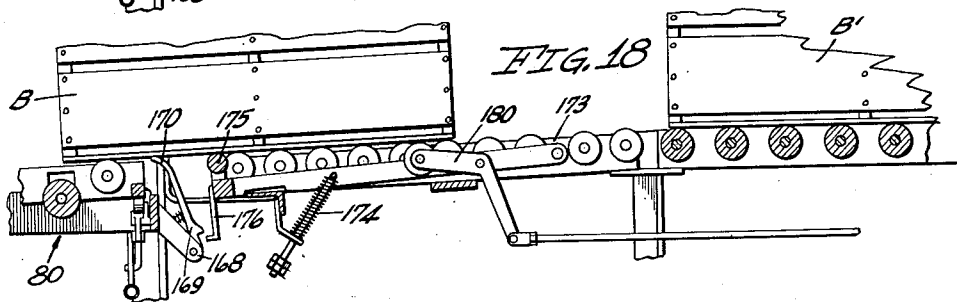
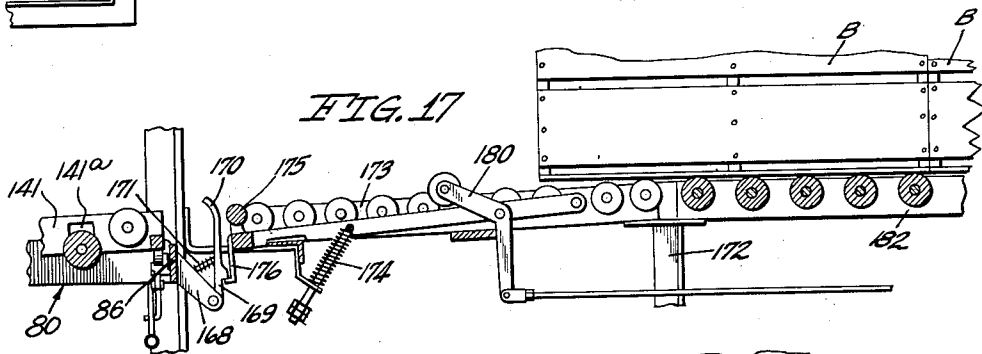
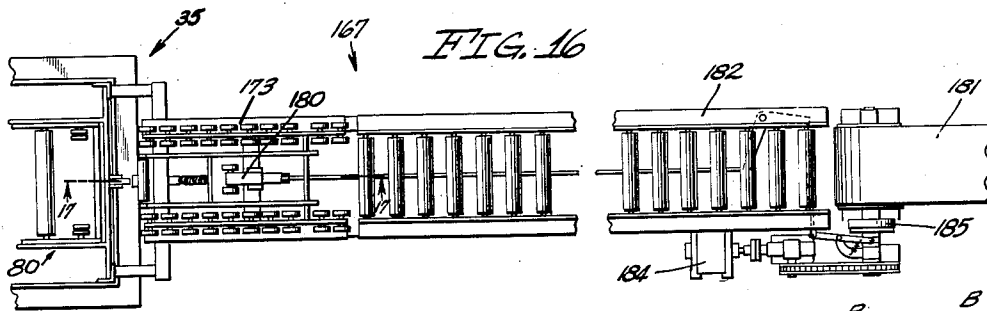

INVENTORS
HALE PAXTON
GERALD C. PAXTON
HARRY D. BENSON
BY
John Keck
ATTORNEY

June 15, 1937.

H. PAXTON ET AL

2,084,048

AUTOMATIC LID NAILING MACHINE

Filed Sept. 5, 1935

11 Sheets-Sheet 8

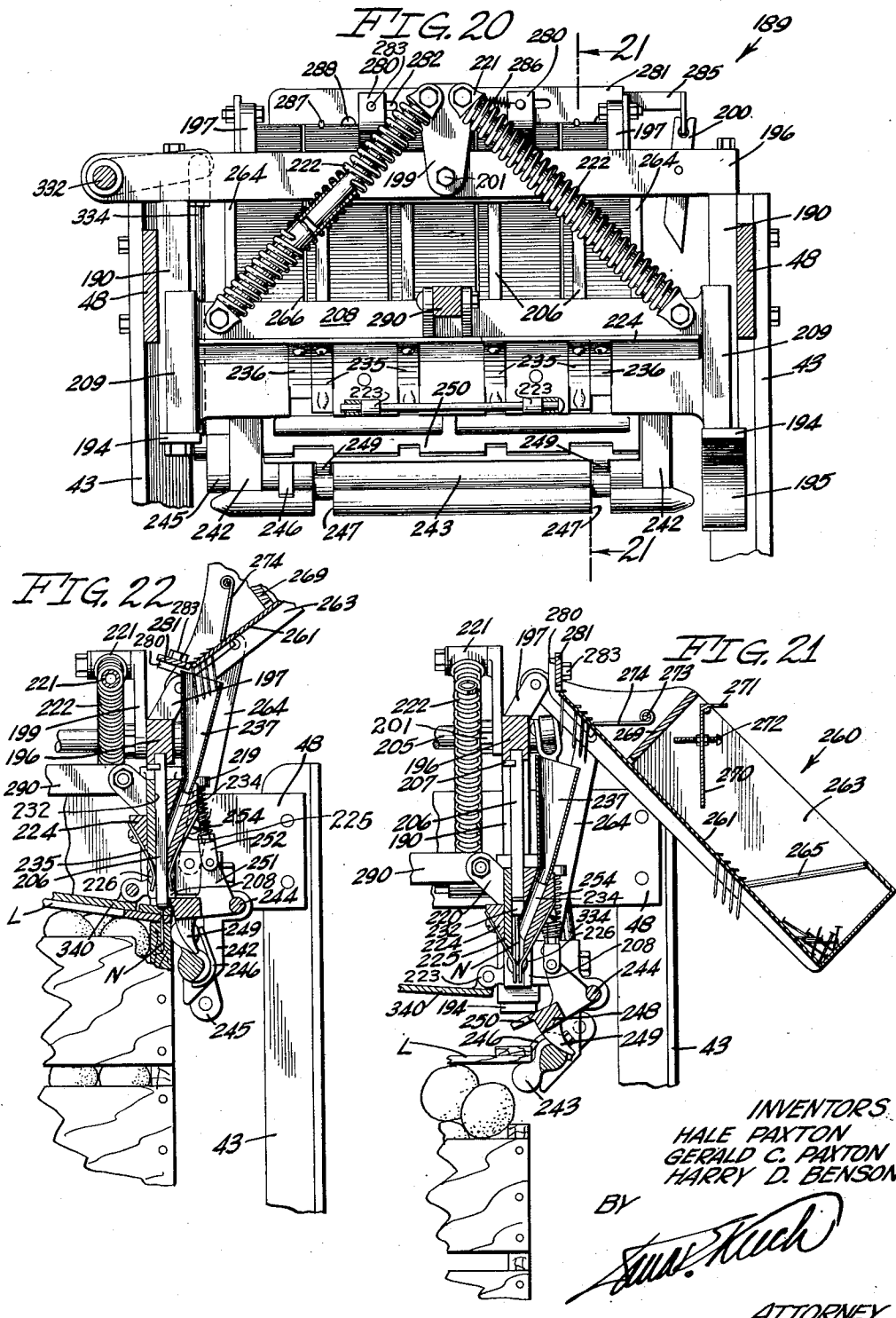

June 15, 1937.

H. PAXTON ET AL
AUTOMATIC LID NAILING MACHINE

2,084,048

Filed Sept. 5, 1935

11 Sheets-Sheet 9

FIG. 23

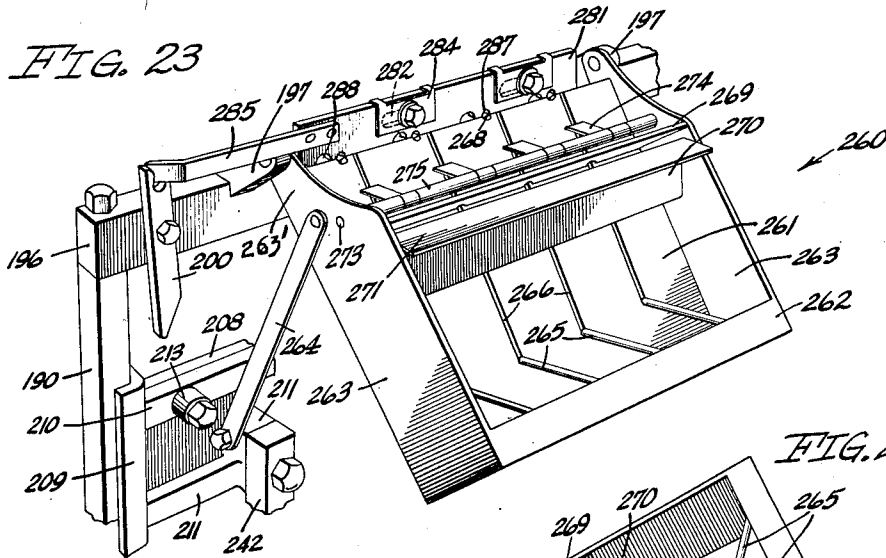

FIG. 24

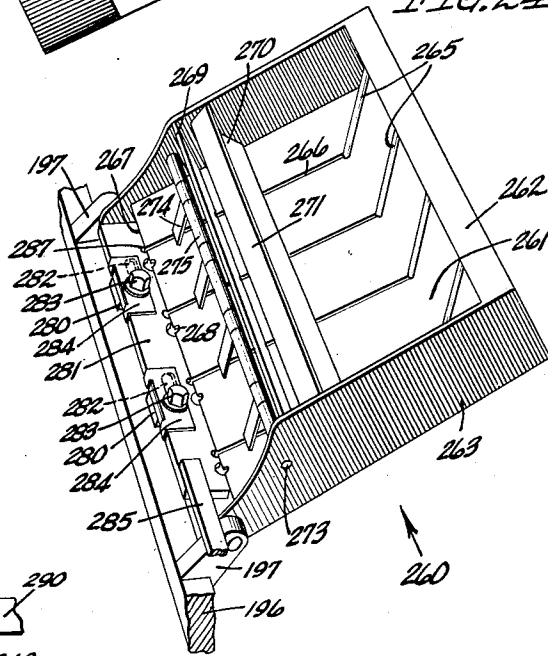
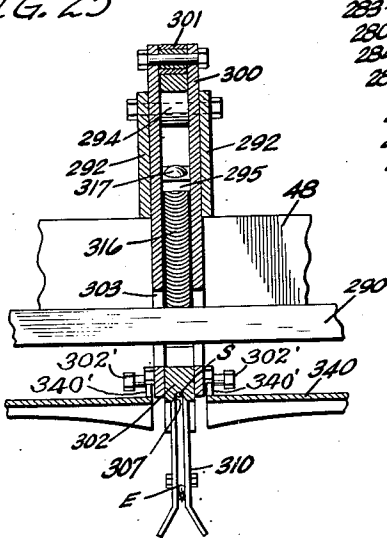

FIG. 25



INVENTORS
HALE PAXTON
GERALD C. PAXTON
HARRY D. BENSON

BY

ATTORNEY

June 15, 1937.

H. PAXTON ET AL

2,084,048

AUTOMATIC LID NAILING MACHINE

Filed Sept. 5, 1933

11 Sheets-Sheet 11

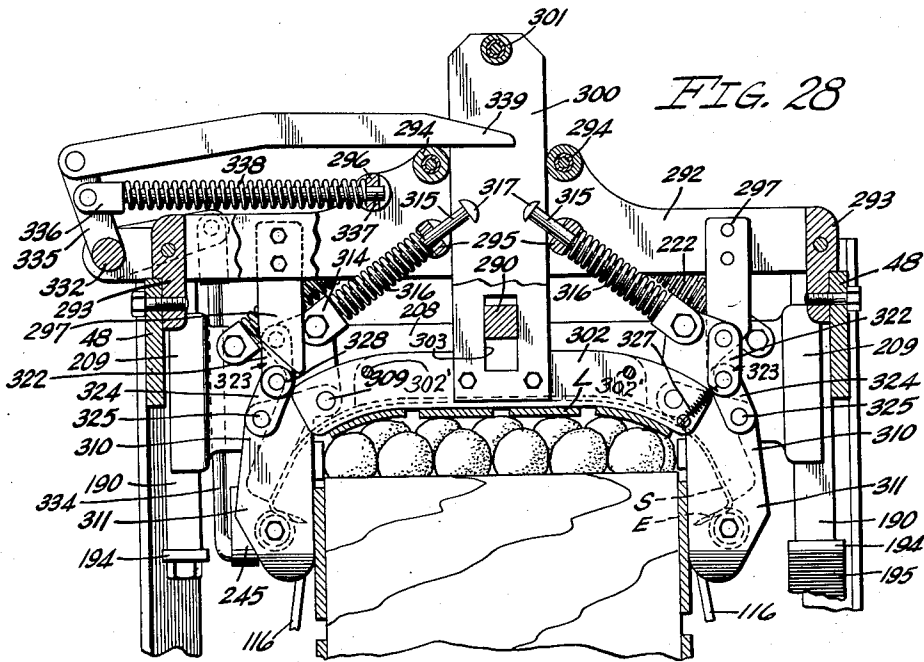

FIG. 28

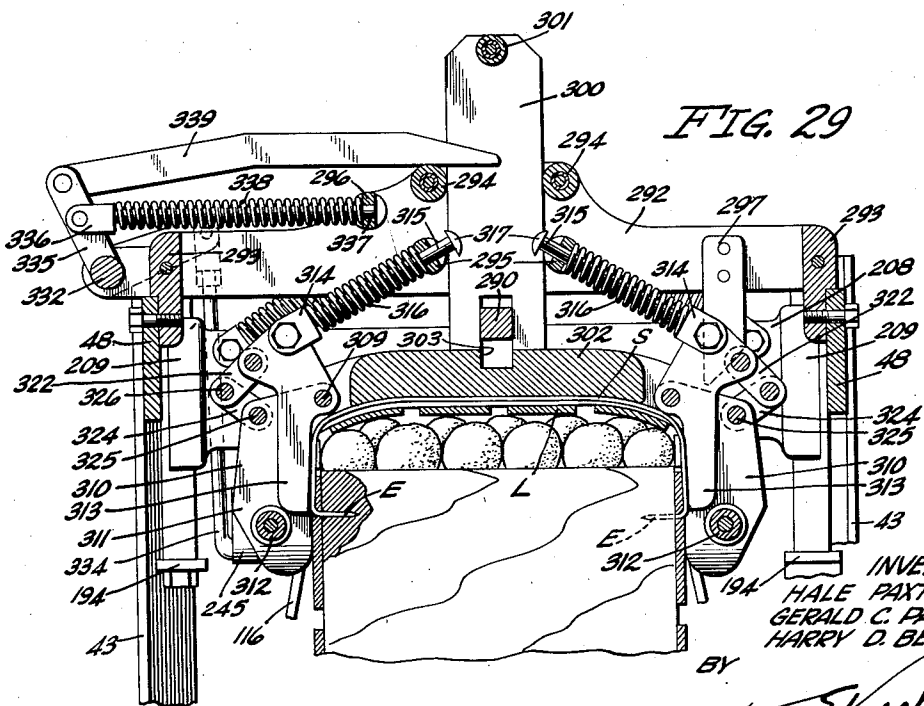

FIG. 29

INVENTORS
HALE PAXTON
GERALD C. PAXTON
HARRY D. BENSON

BY *Paul Keck*
ATTORNEY

UNITED STATES PATENT OFFICE

2,084,048

AUTOMATIC LID NAILING MACHINE

Hale Paxton, Redlands, and Gerald C. Paxton and Harry D. Benson, Santa Ana, Calif., assignors, by mesne assignments, to Food Machinery Corporation, a corporation of Delaware

Application September 5, 1933, Serial No. 688,104

65 Claims. (Cl. 1—10)

Our invention relates to the nailing and strapping art and has particular utility in nailing and strapping lids on boxes overfilled with fresh farm products.

While our invention has wide utility, it is particularly useful in nailing and strapping lids on shipping boxes overfilled with fresh citrus fruit, and an embodiment of the invention particularly adapted for this purpose will be disclosed in this application.

Among other objects, this invention is directed towards producing a simpler, more compact, and stronger machine for nailing and strapping covers on boxes, one which is less expensive to build and operate, one which is easier to service and repair, one which is more dependable in operation, and a machine which is easier on the fresh farm products being packaged.

It is a further object of our invention to produce such a machine in which clutches and other complicated mechanisms are eliminated and yet render the machine completely responsive to the operator and fast enough for the proper performing of the work. It is to be noted that many features of our invention are applicable to cover presses, some are applicable to nailing machines generally, some have particular application to lidding machines alone, while others relate particularly to strapping machines.

It is a further object of our invention to provide such a machine having an improved mechanism for feeding boxes into and from the machine.

Yet another object of our invention is to produce a machine for one or more of the purposes above referred to which is capable of handling work varying in height and width without adjustment and work varying in length with a minimum of adjustment.

The manner of accomplishing the foregoing objects, as well as further objects and advantages, will be made manifest in the following description taken in connection with the accompanying drawings, in which:

Fig. 1 is a plan view of a preferred embodiment of our invention.

Fig. 2 is an enlarged perspective view of one of the nailing units of the machine shown in Fig. 1.

Fig. 3 is a front elevational view of the machine shown in Fig. 1.

Fig. 3a is a detail sectional view taken on line 3a—3a of Fig. 3.

Fig. 4 is a fragmentary view similar to Fig. 3 illustrating the machine just after a lid has been

nailed and strapped to a box and the operator's foot released from the control pedal.

Fig. 5 is a diagrammatic view of the control switch of said machine.

Fig. 6 is a vertical transverse sectional view taken on the line 6—6 of Fig. 3.

Fig. 7 is a fragmentary view similar to Fig. 6 showing the control pedal depressed and the resulting elevation of a box by said machine in the performance of a lid nailing and strapping operation.

Fig. 8 is a fragmentary view illustrating operation of the side flushers of our invention on the higher of two boxes varying in height which these flushers are adapted to automatically perform a fruit gathering function on.

Fig. 9 is an enlarged fragmentary sectional view taken on the line 9—9 of Fig. 7 illustrating the construction of the brake mounting of our invention.

Fig. 10 is an enlarged fragmentary detailed sectional view taken on the line 6—6 of Fig. 3 and illustrating the construction of the brake release mechanism of our invention.

Fig. 11 is a fragmentary detailed horizontal sectional view taken on the line 11—11 of Fig. 10 and looking upward.

Fig. 12 is a detailed fragmentary perspective view of a box stop of our invention illustrating its manner of operation.

Fig. 13 is a fragmentary detailed perspective view of mechanism for operating the tilting elevator table of our invention.

Fig. 14 is an enlarged fragmentary sectional view of the stop shown in Fig. 12.

Fig. 15 is a view similar to Fig. 14 illustrating the stop of our invention in the act of stopping a box.

Fig. 16 is a fragmentary plan view of the box feed mechanism of our invention operating in conjunction with the elevator of our machine to feed boxes thereto, said view being taken in the direction of the arrow 16 in Fig. 3.

Fig. 17 is a fragmentary vertical longitudinal sectional view taken on the line 17—17 of Fig. 16 and illustrating the stop of said feed mechanism while depressed.

Fig. 18 is a view similar to Fig. 17 illustrating a box passing over the stop of said feed mechanism into said machine.

Fig. 19 is a view similar to Fig. 17 showing the parts of said feed mechanism as positioned immediately after said box has been fed into said machine with the stop in elevated position as shown in Fig. 3.

Fig. 20 is an enlarged transverse sectional view taken on the line 20—20 of Fig. 3.

Fig. 21 is a fragmentary detailed sectional view taken on the line 21—21 of Fig. 20.

5 Fig. 22 is a view similar to Fig. 21 illustrating the parts shown therein in operating position.

Fig. 23 is a fragmentary perspective view of one of the nailing units of our invention illustrating the nail stripper and feed mechanism thereof with the stripper pan inclined downwardly.

Fig. 24 is a view similar to Fig. 23 illustrating the stripper pan in upwardly inclined position.

Fig. 25 is a fragmentary detailed view taken on the line 25—25 of Fig. 26.

15 Fig. 26 is an enlarged transverse vertical sectional view taken on the line 26—26 of Fig. 3, and showing the strapper of our invention positioned as when said machine is at the beginning of a strapping operation.

20 Fig. 27 is a view similar to Fig. 26 illustrating the strapper after the first step in a strapping operation which results in preshaping the strap.

Fig. 28 is a view similar to Fig. 27 illustrating the strapper after the next step in a strapping operation which results in the shaping of the cover and tensioning of the driver actuating springs.

30 Fig. 29 is a view similar to Fig. 28 illustrating the strapper just after the final step takes place in the strapping operation which results in the release of the drivers permitting these to make a strap securing movement relative to the strap positioning jaws.

Referring specifically to the drawings, we have shown therein a preferred embodiment of our invention comprising a lid nailing and strapping machine 35, this machine including a frame 36, an elevator 37, a nailing mechanism 38, a strapper 39, and a control mechanism 40.

40 The frame 36

The frame 36 includes a rectangular base 41 having a heavy transverse channel iron 42 shown in Figs. 4, 6, and 7 and four posts 43 which are rigidly secured to the corners of the base 41 and extend vertically upward therefrom. As seen in Fig. 4, end pairs of the posts 43 are connected by bars 46 and by spacers 47.

50 Upper ends of side pairs of the posts 43 (Fig. 4) are connected together by relatively heavy side plates 48 which perform an important function of the frame 36 which will be explained hereinafter. While the side plates 48 might be formed integral with the corner posts 43, they are preferably bolted to said posts and are provided with pairs of holes 49 and 50, as shown in Fig. 2, the purpose of these holes being made evident hereinafter.

Retained in a suitable aperture in the forward side plates 48 is a push pin 55 (Figs. 1, 3, and 4) having a knob on its outer end. This pin is free to play in and out through said aperture but its inner end is upset to prevent its being removed therefrom.

65 Also provided on the posts 43 are cam tracks 56, as shown in Figs. 6 and 7, and stop lugs 57, the latter being preferably welded in place on these posts.

The frame 36 also includes a channel iron 58 shown in Figs. 3 and 6, said channel iron being preferably welded at its ends to the frame bars 46. The channel iron 58 has an aperture formed vertically therethrough at its middle through which a hollow standard 59 extends, the lower end of this standard resting on the channel iron

42 and is preferably welded to these channel irons. Also extending between and secured at their ends to the channel irons 42 and 58 are angle-iron motor struts 60.

The elevator 37

5 The elevator 37 and associated devices will now be described. This elevator includes an electric motor 65 bolted onto the motor struts 60, as clearly shown in Figs. 6 and 7, this motor having a drive pinion 66 which is preferably formed of fiber. The pinion 66 meshes with a jack gear 67 having a nut 68 formed within the hub thereof, this gear being rotatably mounted on a bearing 69 inserted in the upper end of the hollow 15 standard, as clearly shown in Fig. 9.

Covering the pinion 66 and gear 67 is a gear housing brake 70 having a brake lining 71 of the flat ring type, this lining being disposed just above the outer rim of the gear 67, as clearly 20 shown in Figs. 6 and 7. The brake 70 is positioned in a horizontal plane and has its vertical movement upward limited by cap screws 72, compression springs 73 coiled about these screws constantly urging the brake 70 into disengaged 25 position, as shown in Figs. 7 and 9.

Screwed downwardly through the nut 68 is a jack screw 74 which is preferably double pitched as shown, this screw having a cap plate 75, as clearly shown in Figs. 6, 7, and 10. Provided on 30 the lower end of the screw 74 is a guide spider 76.

Resting on and rigidly secured to the cap plate 75 is a central cross-beam 79 of a nailing table 80. This table 80 includes longitudinal side 35 beams 81 and 82 which are welded to opposite ends of the cross-beam 79 and have their opposite ends connected by end cross-bars 85 and 86. The opposite ends of these cross-bars extend into the angles produced by adjacent 40 flanges of the angle iron posts 43, as clearly shown in Figs. 10, 12, and 13, so that said posts are adapted to guide any vertical movement of the table 80.

Referring now particularly to Fig. 10, the 45 cross-beam 79 is seen to be an inverted channel iron with upper portions of the flanges thereof notched for a purpose which will become evident hereinafter. Provided on the beam 79 as by welding so as to be integral therewith are hollow 50 cylinders 87 having flanges 88 at their lower ends and screw caps 89 provided on their upper ends. The screw caps 89 have central apertures to provide access to the interior of the cylinders 87. Provided in each of the cylinders 87 is a plunger 55 cylinder 90 which is also hollow, and has an annular flange at its lower end which retains therein a solid plunger 95, the latter being flanged at its upper end to prevent its complete removal from the cylinder 90. A high compression spring 60 96 is provided in the cylinder 90, this being held downwardly against the plunger 95 by a screw plug 97. The plunger 90 is provided with an annular recess in its outer surface leaving an annular shoulder 98 at its lower end. Disposed 65 in the upper end of the cylinder 87 between the cap 89 and the plunger cylinder 90 is a relatively light coil spring 99 for normally retaining the plunger cylinder 90 in the lower end of the cylinder 87. Lying in suitable slide ways formed 70 in bosses projecting from the bodies of the cylinders 87 are latches 100 which are connected by a rod 101 and normally held inwardly over the shoulders 98 of the plunger cylinders 90 by a coil spring 102 connected to this rod. The rod 75

101 has a finger 103 which extends forwardly and downwardly for a purpose which will become evident hereinafter.

5 The table 80 (Figs. 3, 6 and 7) also has provided thereon a pair of side flushers 110. Each of these flushers has a shaft 111, opposite ends of which are journaled in suitable apertures in the table end cross-bars 85 and 86, and each of these shafts is provided at its opposite ends with upwardly disposed cam arms 112 carrying rollers 113 adapted to travel on the cam tracks 56 and downwardly extending arms 114, end pairs of the arms 114 being connected by springs 115 which yieldably hold the cam rollers 113 against the cam tracks 56.

15 Secured, preferably as by welding, to each shaft 111 and extending upwardly therefrom, as clearly shown in Figs. 3, 4, 6, and 7, are pairs of spring flusher arms 116. Just below their upper ends 20 these arms 116 are bent outwardly to form recesses 117. Secured to the upper ends of each pair of spring arms 116 (Fig. 8) is a main flusher blade 118. Each of the blades 118 has an upwardly extending lid centralizing finger 119. 25 Extending downwardly and outwardly from opposite ends of each flusher blade 118 are brackets 120 through which screws 121 extend, inner ends of these screws screwing into auxiliary flusher blades 122. Compression springs 123 between the blades 122 and the brackets 120 constantly urge each auxiliary blade inwardly into the same plane as its main flusher blade 118.

30 As will be noted in Figs. 3 and 4, the flusher blades 118 by the use of a slot and bolt connection are mounted on the spring arms 116 in such a manner as to permit a limited degree of vertical adjustment thereon.

35 Fixed on spring arms 116 on each of the side flushers 110 is a box guide rail 128, opposite ends 40 129 of this rail being adapted to engage sides of a box on the table 80 so as to centralize this box laterally when the flushers 110 are swung inwardly.

45 Mounted on the endmost spring arms 116, as clearly shown in Figs. 3, 4, 6, and 7, are box locating cams 130, the function of which is to centralize said box longitudinally, when said flushers are swung in, by engaging the ends of the box in a longitudinally trapping relation therewith.

50 Provided in the side beams 81 and 82 of the table 80, as clearly shown in Figs. 3, 4, and 12, are holes 131 and 132. In Fig. 12 these holes are both shown as empty. In Figs. 3 and 4 cap screws 133 are shown extending through the holes 131 to support rollers 134 between said beams 81 and 82 at opposite ends of the table 80. A screw 133 is removed in Fig. 12 to indicate the position of one of the holes 131 in the beam 81. Each of the rollers 134 has a relatively heavy solid shaft 135 which is supported at its opposite ends by the cap screws 133 which are threadedly received therein. The rollers 134 also are cut away centrally to provide stop accommodating spaces 136.

65 Pivotaly mounted on the shaft 135 (Figs. 10, 11, and 12) at the discharge end of the table 80 is a tilting roller conveyor 140, this conveyor including side members 141 which have holes 70 141a (Fig. 3) for freely receiving the other shaft 135, and an end member 142 (Fig. 13) which is preferably welded to the side members to rigidly space these, the member 142 being at the receiving end of the table 80. Pivotaly mounted 75 on the end bar 86 of the table 80, as clearly shown

in Fig. 13, is a bell crank 143 having a roller on one arm thereof engaging the lower surface of the member 142 and having the other arm thereof connected by a link 144 to one of the downwardly extending flusher arms 114. The operation of the bell crank 143 and link 144 is such that when the table 80 is in lowermost position, as shown in Fig. 3, the conveyor 140 is tilted. Provided on the conveyor 140 is between the rollers 134 is a series of idle rollers 145. The opposite ends of the tilting conveyor side members 141 are also provided with skate wheel rollers 146, as clearly shown in Figs. 12 and 13. The roller 145 at the middle of the table 80 is shorter than the balance of these rollers, as clearly shown 15 in Fig. 10, and is pivotaly mounted at its ends on U-shaped brackets 147 which extend around the cylinders 87 and permit access to these cylinders from above the table 80.

20 Referring now to Figs. 12, 13, 14, and 15, a box stop 153 is here shown in the form of a plate having a vertical body 154 bent therefrom, the latter being mounted on four bolts 155 which are supported on the cross-bar 85 and a plate 156 extending downwardly from this cross-bar. 25 Also pivotaly mounted on cross-bar 85 is a bell crank 157, one arm of this bell crank being loosely connected by a link 158 to the stop 153, and the other end of the bell crank being connected by a link 159 to an adjacent downwardly extending arm 114 of one of the flusher shafts 30 111, as clearly shown in Fig. 12. When the table 80 is elevated it is thus seen that the bell crank 157 is rocked by the swinging of the side flushers to draw the stop 153 downwardly.

35 Provided on the front table beam 81, as clearly shown in Figs. 3 and 4, is a downwardly extending shut-off cam 165 and a safety rod guide and shut-off finger 166, the purpose of these being made evident hereinafter.

40 Referring now particularly to Figs. 3, 4, 16, 17, 18, and 19, it is seen that we have provided a novel box feeding mechanism 167 for feeding boxes into the automatic lid nailing and strapping machine 35. The apparatus 167 includes 45 a bracket 168 mounted on the table end cross-bar 86 and pivotaly carrying a catch 169 having a release finger 170 and urged into upright position by a spring 171.

50 Supported on adjacent corner posts 43 of the machine 35 and on legs 172 is a skate wheel roller section of conveyor 173 having the rollers disposed on opposite sides of a central space in the conveyor. Pivotaly mounted in said central space and continually urged upward by a spring 174 is a stop 175 having a hook finger 176 55 which lies in the path of the catch 169 as the latter moves vertically with the table 80 during the operation of the machine 35. Also pivotaly mounted in this open space of the conveyor section 173 is a power conveyor control bell crank 180. Aligned with the conveyor section 173 is a power conveyor 181, this conveyor being adapted to run continuously excepting when the bell crank 180 is depressed, this depression temporarily disconnecting the power from the conveyor 181. Disposed in between the power conveyor 181 and the conveyor section 173 is an idle roller conveyor section 182 which is adapted to act as an accumulator for boxes discharged 70 from the power conveyor 181.

75 Disposed at the discharge end of the machine 35 is a discharge conveyor 183, one end of which may be supported upon an adjacent pair of the corner posts 43.

The nailing mechanism

The nailing mechanism 30 consists primarily of two nailing units 188 and 189 (Fig. 3) these being substantially identical so that a description of one with an explanation of the differences will suffice for both. The nailing unit 189 (Figs. 2 and 20) has side slide bars 190 having pins 191 by which the unit may be supported upon the side plates 48 of the frame, these units normally being rigidly mounted upon the side plates 48 by cap screws 193 extending either through pairs of holes 49 or through pairs of holes 50 in the side plates 48 and being threadedly received in suitable holes provided in the side slide bars 190. Secured to lower ends of the side slide bars 190 are chuck beam stops 194, the front stop 194 having a lid guiding hook 195 secured thereon. Extending between and preferably rigidly connected at its opposite ends to the upper ends of the side slide bars 190 is a cross-bar 196, this bar having stripper supporting ears 197 (Figs. 2 and 20 through 23), a bearing 198 provided by a rearwardly extending end thereof, an upwardly extending spring hanger 199, and a picker operating cam lever 200 pivotally mounted thereon. The spring hanger 199 is connected to the cross bar 196 by a single cap screw 201. Formed in the lower face of the cross-bar 196 is a groove 205, and square nail drivers 206 have their upper ends held in place in the groove 205 by a key 207 which extends into suitable notches provided in the drivers 206, the key 207 being secured in any suitable manner to the lower face of the cross-bar 196.

Disposed between the side slide bars 190 (Figs. 2 and 23) is a chuck beam 208 having guide shoes 209 provided on its opposite ends, these guide shoes embracing the side slide bars 190 so as to guide the chuck beam vertically thereon. The chuck beam 208 is reinforced by welding blocks 210 along its upper edge and blocks 211 along its lower edge adjacent the guide shoes 209 and then by blocks 212 welded in spaced relation along the lower edge of the chuck beam. One of the blocks 210 at the front of the machine provides a mounting for a picker cam actuating roller 213. Secured to the guide shoe 209 at the front of the machine and on nailing unit 189 alone is a control rod guide and release finger 218. Provided on the upper edge of the chuck beam 208 at the middle of the beam is a lid centralizer spring lug 219. As shown in Figs. 20, 21, and 22, strapper limit bar lugs 220 extend inwardly from the central portion of the chuck beam 208. Pivotally mounted at their opposite ends on the spring hanger 199 and on opposite ends of the chuck beam 208 are telescopic spring spindles 221 on which heavy compression springs 222 are mounted under constant tension. Provided on the lower edge of the chuck beam 208 and extending inwardly is a pair of crown sheet attaching eyes 223.

Formed on the chuck beam 208 (Figs. 21 and 22) and extending inwardly across its entire length is a chuck spring supporting boss 224, chuck springs 225 being secured by screws to an inclined lower face of this boss and extending through suitable notches in the lower edge of the chuck beam 208 and downwardly on the opposite side of the chuck beam. The lower ends of the chuck springs 225 are bent to extend vertically downward and pockets 226 are formed in these springs, preferably by expressing the material thereof outwardly.

Resting on top of the lower reinforcing blocks

212, disposed between the upper reinforcing blocks 210, and yieldably held against the chuck beam 208 by springs 230 is a compound spring chuck block 231 which is clearly shown in Fig. 2. This block 231 has a plurality of driver guideways 232 (Figs. 2, 21 and 22) provided therein and a rearwardly extending boss 233 opposite each of these guideways, this boss providing a nail feeding duct 234 leading into the channel 232 and inwardly inclined faces against which 10 chuck springs 235 are secured by screws. These springs are substantially identical with springs 225 (Fig. 21) and extend inwardly and downwardly to cooperate with the springs 225 in a manner which will be made manifest hereinafter. 15

In the preferred embodiment of our invention there are six guideways 232 shown in the compound chuck block 231, the endmost pairs of these guideways being closer together than the inner pairs so that the outer pair of bosses 233 20 are formed as a single unit. As shown in Fig. 2, only one of each of the endmost pairs of the guideways 232 is used, the purpose of these two guideways being close together being to permit operation upon boxes differing considerably in 25 width, as will be explained hereinafter. When any of the guideways 232 are not used, it has been found preferable to cover up their lower ends as by dummy chuck springs 236 secured both to 30 the boss 233 and to the boss 224 opposite this guideway.

Removably supported in each of the ducts 234 and connecting therewith is a nail funnel 237.

Mounted on the chuck beam reinforcing block 211, as clearly shown in Fig. 2, are brackets 242, 35 these pivotally carrying opposite ends of an end tucker 243 and a lid depressor and centralizer 244. The end tucker 243 comprises two substantially cylindrical bodies, one of which is disposed 40 on the axis of rotation of the tucker and the other of which is disposed parallel with the first body and radially therefrom, the two being connected by a substantially continuous web of metal. After extending through the rearmost 45 bracket 242 the tucker 243 provides an arm 245 which extends outwardly therefrom, as shown in Fig. 2. The tucker 243 normally extends downwardly at an angle as clearly shown in Fig. 21 so that it is adapted to support an end of a box 50 lid as shown in this figure. Secured on the tucker 243 to provide a stop for the rear edge of such a lid is a cam member 246. Also formed in the tucker 243, as clearly shown in Figs. 2, 20, 21, and 22, is a pair of slots 247.

The lid depressor and centralizer 244 has a 55 cross-section as shown in Figs. 21 and 22 which includes a body 248 having arcuate guards 249 extending downwardly into the grooves 247 in the tucker 243, and a lip 250 which extends inwardly 60 from the body 248 at the upper edge thereof and is provided with suitable notches 250a opposite each of the nail driver guideways 232. The lid depressor and centralizer 244 has an upwardly 65 extending hump 251 (Figs. 2, 21, and 22) to which is pivotally secured a clevis 252 carrying a rod 253 which extends through a suitable aperture in the lug 219, a compression spring 254 being coiled about the rod 253, said spring constantly urging 70 said lid depressor and centralizer 244 to rotate downwardly into the position in which it is shown in Figs. 2, 20, and 21.

Referring now particularly to Figs. 21, 22, 23, and 24, it will be seen that the nailing unit 189 also includes a nail hopper 260 having a floor 261, 75

a rear wall 262, and side walls 263, the inner ends of the latter being pivotally connected to the hopper mounting lugs 197. The hopper side walls are also connected by links 264 to the reinforcing block 211 of the chuck beam 208. Extending from the upper edge of the rear wall 262 to spaced points in the floor 261 are nail agitating rods 265, there being nail advancing slots 266 extending forwardly from these rods to a front edge 267 (Fig. 24) of the floor 261. Formed in the edge 267 adjacent each of the slots 266 is a relatively small notch 268. The hopper 260 has a fixed baffle wall 269 extending between the walls 263 and rigidly secured thereto, there being clearance between the lower edge of the wall 269 and the floor 261 adjacent the slots 266 to permit nail heads to pass underneath the baffle wall 269 as the stems of the nails extend through the slots 266. Pivotaly mounted between the walls 263 is a pivoted baffle 270, this baffle having a flange 271 at its upper end and a set screw 272 for limiting its downward swinging movement when the hopper 260 is extended upwardly, as shown in Fig. 24. Also extending between the walls 263 is a rod 273 on which are pivotally mounted a series of traps 274, these being held in spaced relation by spacers 275. Each of the traps 274 is disposed over one of the slots 266, as clearly shown in Figs. 23 and 24.

As shown in Figs. 20, 21, and 22, two brackets 280 are connected to the lower surface of the hopper floor 261 and extend forwardly beyond the front edge 267 of said floor. Slidably mounted on these brackets is a picker bar 281 having a pair of slots 282 through which cap screws 283 extend, these screws then screwing into suitable apertures in the brackets 280. Disposed between the heads of the cap screws 283 and the picker bar 281 so as to cover the slots 282 are guard washers 284. Fixed on the picker bar 281 is an actuating arm 285, the extremity of which is bent as shown in Fig. 23 to extend into the upper bifurcated end of the cam lever 200 by which the picker bar 281 is adapted to be actuated. As shown in Figs. 1 and 20, a coil spring 286 attaches to one of the brackets 280 and to the picker bar 281 so as to constantly urge this picker bar into the position in which it is shown in Figs. 20 and 23.

The picker bar 281 has its lower edge both parallel and close to the front edge 267 of the hopper floor 261, and this edge of the picker bar is provided with a series of pairs of notches, one pair for each of the slots 266 of the hopper floor. Each of these pairs of notches comprises a small notch 287 and a large notch 288, the notch 287 of each of these pairs being opposite one of the notches 268 when the picker bar is positioned as shown in Fig. 23, while the large notch 288 of that pair is on the opposite side of that notch 268 from the slot 266 adjacent that notch 268. The notches 287 and 288 are spaced apart the same distance from their centers as is each of the slots 266 and adjacent notch 268.

In the operation of the machine, a considerable quantity of nails are carried in the hopper 260, which apply a considerable pressure to the pivotal connection between the links 264 and the inner portions 263 of the hopper walls 263. Owing to the fact that these links and inner portions of the walls 263 form toggle joints and the weight of the nails thus applied to the intermediate pivots of these joints tends to maintain the links of these toggle joints in extended relation, the weight of these nails is thus effective in strongly restricting the elevation of the chuck

beam 208. The weight of these nails on these toggle joints, however, is yieldable and as will be pointed out hereinafter, is overcome in the operation of the machine by the upward pressure against the chuck beams 208, so that the links 264 lift, swinging the hopper pans and the load of nails carried thereby upwardly and collapsing said toggle joints formed by the links 264 and the hopper walls 263 (see Fig. 23).

We have now completed the description of the 10 nailing unit 188. The nailing unit 188 is an exact duplicate of nailing unit 189 excepting that instead of a hook 195 being formed on the forward chuck beam stop 194, the corresponding chuck beam stop in nailing unit 188 merely has a shallow 15 V-shaped lid end guide 289, as shown in Fig. 3. Connecting the lugs 220 of the nailing units 188 and 189 is a strapper height limit bar 290.

The strapper 39

The strapper 39 of our invention is best shown in Figs. 1, 3, 4, 6, 25, 26, 27, 28, and 29. This strapper includes a pair of bridge bars 292 (Figs. 25 and 29) mounted on blocks 293 secured to the frame side plates 40 of our invention. Rotatably 25 mounted between the bridge bars 292 are rollers 294 and spring heads 295 and 296, the spring heads 295 being directly beneath the rollers 294. Each bridge bar 292 has a driver release cam 297 rigidly secured thereon and depending therefrom. 30 The lower end of each of these cams 297 has an oblique cam face 298.

Slidably vertically between the bridge bars 292 and the rollers 294 and spring heads 295 is a strapper stem 299, this stem consisting of two 35 plates 300 having a roller 301 rotatably mounted between these plates on a suitable spacer. The lower ends of the plates 300 extend on opposite sides of and are rigidly secured to a saddle bar 302, the stem and saddle bar having a vertically 40 elongated opening 303 through which the strapper height limit bar 290 extends.

The saddle bar 302 (Figs. 25, 28, and 29) has an arched conformation corresponding approximately with the transverse shape which it is 45 desired that this bar transmit to the middle portion of a lid to be strapped. The lower face of this bar is provided with a recess 307 (see Fig. 25) which connects at its opposite ends to vertical strap jaw guideways 308 through which extend pins 50 309 mounted on opposite ends of said saddle bar. Pivotaly mounted on the pins 309 in the recesses 308 are strapper jaws 310, each jaw comprising a pair of plates 311 which are spaced at their 55 lower ends by a strap end stop 312. The lower extremities of the plates 311 (Fig. 25) are bent outwardly to form strap end guides for assisting in feeding a strap into the strapper 39.

Disposed between the plates 311 and also pivotally mounted on the pins 309 of each jaw 310 60 is a driver 313, the function of which is to secure an end of a strap to a side of a box. An upper end of each driver 313 is connected by a clevis 314 to a rod 315 which extends through a spring head 295. A coil compression spring 316 65 surrounds the rod 315 and is maintained under tension by a head 317 on the end of the rod 315. The upper end of each driver 313 also pivotally connects to a link 322 of a toggle 323, the other link 324 of this toggle being pivotally connected 70 to the jaw 310 by a pin 325. The links 322 and 324 are connected together by a pin 326, this pin having a spring 327 (see Fig. 28) attached to one of its extending ends, the other end of the spring being attached to the saddle bar 302. The op- 75

posite end of the pin 326 carries a roller 328 which is disposed directly beneath the oblique cam face 298 of one of the cams 297.

Journalled in the bearings 198 of the cross-bars 196 of the two nailing units 188 and 189 is a shaft 332 having arms 333 at its opposite ends, as shown in Figs. 1 and 2, these arms being connected by links 334 with the arms 245 on the end tuckers 243. As shown in Figs. 26 to 29 inclusive, the shaft 332 carries an arm 335 opposite the strapper 39, this arm having a clevis 336 pivoted thereon, a rod 337 on this clevis extending through the spring head 296 and carrying a coil compression spring 338 which constantly tends to rotate the shaft 332 and maintain the end tuckers 243 rotated into their downwardmost position in which extending ends of these tuckers engage the brackets 242 as shown in Fig. 21.

Pivotally connected to the upper end of the arm 335 is a wedge 339 which overlies one of the rollers 294 and extends beneath the strapper stem roller 301, as shown in Fig. 26.

Pivotally connected at their outer ends to crown sheet ears 223 and loosely connected at their inner ends to the strapper saddle bar 302 by bolts 302' provided on said bar, as shown in Figs. 1, 3, 20, 21, 22 and 25, are halves 340 of a crown sheet 341. Lugs 340' provided on the crown sheet halves 340 slide horizontally on the bolts 302' whenever there is relative vertical movement between the saddle bar 302 and the chuck beams 208. Pivotally mounted on the crown sheet halves 340 along their edges as shown in Fig. 1 are cover slat spreader jaws 342, the inner ends of which are lifted by suitable springs disposed thereunder so as to permit the outer ends of said jaws to swing upwardly and outwardly when brought into vertical engagement with the side slats of a lid, said jaws thus being separated to spread said side slats laterally.

The control mechanism 40

The control mechanism 40 of our invention includes a switch 343 which is preferably mounted on a suitable bracket 344 fixed upon the channel member 42, as shown in Fig. 6. The switch 343 is diagrammatically shown in Fig. 5 and is an ordinary reversing switch interposed between the main line conductors *a*, *b*, and *c* and the three terminals of the motor 65. The switch 343 includes a stem 345 having two sets of contact makers *X* and *Y*. When the stem 345 is positioned as shown in Fig. 5, the motor 65 is shut off and no contact is made by either of the contact makers *X* or *Y*. When the stem 345 is moved upwardly the electrodes *a*, *b*, and *c* are connected with the motor 65 through a circuit *X'* to cause the motor to run in a direction so as to elevate the table 80. When the stem 345 is moved downwardly from the position in which it is shown in Fig. 5, the electrodes *a*, *b*, and *c* are connected through a circuit *Y'* with the motor 65 to cause the motor to run in the opposite direction or so as to lower the table 80. Connecting with the lower end of the stem 345 is a spring 346 which maintains the stem 345 in the position in which it is shown in Fig. 5 unless a lifting or depressing force is applied to this stem. Extending upwardly from the stem 345 is a rod 347 having collars 348 and 349.

Pivotally mounted at its opposite ends in the cross-bar 46 (Fig. 4) of the frame 36 is a control rock shaft 360 having two arms 361 and 362 (Figs. 6 and 7) extending forwardly therefrom,

two arms 363 and 364 extending upwardly therefrom, and one arm 365 extending rearwardly therefrom. The arm 365 is pivotally connected to a link 366 which extends downwardly, as shown in Fig. 6, and is provided with a horizontal loop 367 which encircles the rod 347 between the collars 348 and 349. The arm 363 engages the downwardly extending shut-off cam 166 when the table 80 is in its lowermost position, as shown in Figs. 3 and 6, so as to rock the shaft 360 and relieve the switch stem 345 of all pressure from the eye 367 and permit this switch to assume the position shown in Fig. 5 in which it shuts off the motor 65.

Pivotally connected with the arm 361 is a rod 370 which extends downward through a guide bracket 371 mounted on the frame base 41 and connects at its lower end to a foot pedal 372 which is pivotally mounted on the base 41. The rod 370 has a collar 373, a compression spring 374 between this collar and the bracket 371, and a pair of lock nuts 375 beneath the bracket 371 to limit the action of the spring 374 on the rod 370 when the pedal 372 is relieved from all manual pressure.

Connected by a clevis to the arm 362 (Figs. 3 and 4) and extending upwardly is a safety shut-off rod 376, this rod extending upwardly through suitable holes in the safety shut-off fingers 166 and 218. Mounted on the upper end of this rod is a head 377 (see Fig. 3a), this head having a suitable opening therein having a chamfered edge and adapted to receive the push pin 55 so as to adjust the rod 376 vertically in such a position that the switch 343 will shut off the motor 65. In other words, and as will appear more particularly hereinafter, the opening in the head 377 is so positioned relative to the pin 55 that when the latter is inserted into said opening, the head 377 will be held in such a position vertically that the rod 376 will, through the arm 362, shaft 360 and arm 365, so determine the vertical location of the link 366 that the eye 367 of the latter presses neither against the collar 348 nor the collar 349, thereby permitting the switch spring 346 to neutralize switch 343 as shown in Fig. 5, and shut off motor 65.

Adjustably mounted on the rod 376 is a collar 378, which is normally so positioned that when the nailing table 80 is lifted without a box thereon or with a box thereon which is lower than the lowest box which the machine is designed to accommodate, the finger 166 on the table 80 engages the collar 378 and lifts upon the rod 376 so as to rock the shaft 360 to depress the eye 367 as shown in Fig. 4, which operates the switch 343 to stop the motor and even to reverse the latter until the table shall be moved back downwardly enough to allow the eye 367 to rise a short distance from the position in which it is shown in Fig. 4, providing the operator's foot is held on the pedal 372. Whenever the table would thus be stopped by engagement of the finger 166 with the collar 378, it would immediately give warning to the operator that a box not suitable for lidding was deposited in the machine, and the operator would thereupon immediately relieve the pedal 372 from the pressure of his foot permitting the spring 374 to rock the shaft 360 and actuate the switch 344 to throw the motor into reverse as shown in Fig. 4, thereby returning the table 80 under power to its lowermost position as shown in Fig. 3.

Operation

In commencing the operation of our machine 35, the parts thereof are positioned as shown in Figs. 1, 2, 3, 5, 6, 10, 11, 12, 13, 14, 16, 17, 20, 21, 23, 25, and 26. The balance of the views are views illustrating the machine during its operation. To begin with, the motor 184 (Fig. 16) is started which drives the power conveyor 181 through the clutch 185 owing to the fact that the bell crank 180 is not depressed. Also the conductors *a*, *b*, and *c* are connected to a suitable source of three phase current capable of driving the motor 65 in opposite directions when these conductors are connected with this motor through the circuits X' and Y'.

As will be noted in Figs. 3, 5, and 6, the control eye 367 of the switch 343 is now disposed out of contact with either of the collars 348 or 349, thus permitting the spring 346 of the switch 343 to neutralize the switch stem 345 and shut off the motor 65. As before mentioned, this position of the eye 367 results from engagement between the table shut-off arm 363 and the shut-off cam 165 when the table 80 is in its lowermost position, as shown in Figs. 3 and 6.

It is also desired to point out that at this time the plungers 95 are held downwardly, as shown in Fig. 10, by the latches 100 engaging with the shoulders 98 so that the plungers 95 hold the gear housing brake 70 downwardly with the lining 71 pressed against the gear 67, as shown in Fig. 6. It is also noted that the side flushers 110 are swung outwardly as shown in Fig. 6, and that the receiving end of the tiltable conveyor 140, is as shown in Figs. 3, 13 and 17. At this time also the stop 175 is held downward by the catch 169, as shown in Fig. 17. A box B being fed from the power conveyor 181 onto the accumulator 182 is eventually pushed onto the conveyor section 173 by following boxes until box B passes over the bell crank 180 which shuts off the conveyor 181 by disconnecting the clutch 185. Owing to the depression of the stop 175 and the inclination of the conveyor section 173 in the direction of the machine 35, the box B now rolls by gravity onto the tilting conveyor 140 where its foremost end engages the stop 153, as shown in Figs. 3 and 15. The box B is shown as over-filled with oranges O, a superposed layer O' of which extends above the upper edges of the box.

As the box B passes over the release finger 170 it swings this, as shown in Fig. 18, to release the hook finger 176 from the catch 169. As the stop 175 is uncovered by the box B before the finger 170, this stop is lifted into its upward position by the spring 174, as shown in Fig. 19. It is also noted that as the box B uncovers the bell crank 180 this is permitted to rise again as shown in Fig. 19, thus throwing in the clutch 185 and starting the power conveyor 181. This action again starts the feeding of boxes from this conveyor onto the accumulator 182 so that box B', which follows box B, is pushed onto the conveyor section 173 and rolls down this against the stop 175. In this position the box B' depresses the bell crank 180, thus discontinuing operation of the power conveyor 181.

Either before the box B enters the machine 35 or after it has come to a stop, as shown in Fig. 3, the operator takes a strap S which is preferably in the form of a straight wire having nail-like pointed driving ends E bent from its ends, and inserts this strap in the strapper 39. When strap S is thus inserted, the strap ends rest

against the stops 312 (Fig. 26) and the body of the strap is arched upwardly so as to extend into the notch 307 along the lower face of the saddle bar 302. The space between the plates 311 of the jaws 310, as shown in Fig. 25, is just sufficient to slidably receive the strap ends E.

The operator now inserts a lid L in the machine, as clearly shown in Figs. 3, 21, and 26, so that ends of the lid rest upon the end tuckers 243, the rear edge of the lid engaging the stops 246 provided on these tuckers. The lid L is a "unitized" lid formed of a plurality of spaced parallel longitudinal slats of relatively thin material, such as ply wood, connected at their opposite ends by relatively thin transverse end cleats stapled or nailed to the slats.

The machine 35 is now ready for initiating a power cycle of operation for nailing and strapping the lid L to the box B. The entire operation is brought about by the operator stepping on the foot pedal 372 and the progress of the operation is retained under control of the operator by his manipulating this pedal. As shown in Figs. 6 and 7, depression of pedal 372 rocks the control shaft 360 so as to swing the arm 364 forwardly. This arm engages the finger 103 and withdraws the latches 100 from over the shoulders 98. Thus released, the plunger cylinders 90 are thrust upwardly by the springs 96. The gear housing brake 70 is thus relieved from the pressure of these springs and the relatively light pressure of the springs 99 is substituted therefor. This release of the brake 70 from pressure by the springs 96 permits this brake to be lifted by its springs 73, as shown in Fig. 9, thus releasing the gear 67 from the brake 70.

Simultaneously with or shortly following this release of the brake 70, the eye 367 engages the collar 348, as shown in Fig. 7, and lifts this to cause the switch 343 to complete the circuit X' between the conductors *a*, *b*, and *c* and the motor 65. This causes the motor to rotate in the direction of the arrow D in Fig. 7 so as to rotate the gear 67 and the nut 68, thereby lifting the jack screw 74 and the table 80 mounted thereon.

As the nailing table 80, carrying the box B, starts upwardly the flusher cam rollers 113 (Fig. 7) are shifted inwardly by the corner post flusher cams 56, thus rocking the shafts 111, swinging the side flushers 110 inwardly into flushing position, and swinging the lower arms 114 on the shafts 111 outwardly. The outward swinging of the arms 114, to certain of which are attached links 144 and 159 (Figs. 12 and 13), results in rocking the bell crank 143 to lower the tilting conveyor 140 into horizontal position, as it is shown in Fig. 4, and also in rocking the bell crank 157 so as to draw down on the stop 153 while it is under pressure of the springs 160, as shown in Fig. 15. As this stop comes below the bottom edge of the box B it is urged by the springs 160 into the space 136 (Fig. 14) beneath this box, thereby no longer being in a position to prevent discharge of the box from a machine at the conclusion of the lidding and strapping operation.

As will be noted in Fig. 7, the upper edges of the sides of the box B are of such a height as to permit the auxiliary flusher blades 122 of the flushers 110 to pass inwardly over these sides as shown in this view. This moves in side rows of the superposed layer of oranges O', these oranges being engaged by both the main flusher blades

118 and the auxiliary blades 122. In case a higher box than the box B were to be used, as the box B' shown in Fig. 8 in which the sides of the box come just below the lower edges of the main flusher blades 18, the auxiliary blades 122 engage the outer surface of the sides of the box so as to compress the springs 123 and permit the main blades 118 to extend inwardly over the upper edges of the box sides and shift the side rows of the oranges O' inwardly over the sides.

The swinging in of the side flushers 110 also brings the box centralizers 129 into engagement with sides of the box B, as shown in Figs. 3 and 7, thus centralizing this box laterally on the nailing table 80 while the springs and longitudinal box centralizing cams 130 engage the ends of the box and centralize this longitudinally in proper position on the nailing table 80 for performing a lidding and strapping operation on the box. As shown in Figs. 3, 4, 6, and 7, the lateral centralizers 129 engage the box at points spaced longitudinally from the points at which these centralizers are attached to the arms 116. This permits a slight yielding horizontally of the centralizers 129 when a box of excessive width is being handled in the machine. Adaptation of the side flushers 110 to boxes varying in width is effected by the springy nature of the arms 116 on which the flusher blades are carried.

The flushing movement of the side flushers 110 is timed with the elevation of the table 80 by cam tracks 56 so that the lid positioning fingers 119 are brought inwardly as they come opposite the lid L and positively position the lid L laterally for application to the box B.

At the moment the side flushers 110 come into flushing position, as shown in Fig. 7, the box B has been elevated practically to the position in which it is shown fragmentarily in Fig. 21. As box B continues thereafter to rise the end tuckers 243 contact the ends of the box B and end oranges in the layer O'. As the box lifts the end tuckers 243 these end tuckers swing inwardly, tucking these end oranges inwardly over the box ends and holding these oranges in inward position as they are brought into contact with the lid L which is disposed immediately thereabove. As the oranges O' engage the lid L the lid is lifted bringing its ends against the lip 250 of the lid depressor and centralizer 244. The upward swinging of the end tuckers 243 causes the lid ends to engage the lips 250 and swing the centralizers 244 upward. In case one of the lid ends should not be of sufficient bulk to accomplish this the lid stop cam member 246 lifts this lid depressor and centralizer 244 substantially to the position in which this is shown in Fig. 22. In comparing Figs. 21 and 22, it is clear that the upward rocking of the end tuckers 243 on which the lid stop cam member 246 is mounted, inevitably brings this lid stop member against the element 244 as the box moves upwardly. Normally, of course, the member 244 is swung upwardly by the pressure of the cleated lid end against the lip 250 when the end of the box lifts on the tucker 243 and the latter pushes upward on the cleated lid end. Obviously, the centralizer body 248 and downwardly extending arcuate guards 249 engage the ends of the lid L and centralize this longitudinally for application to the box B. The guards 249 prevent the lid extending between an end tucker 243 and the centralizer body 248 thereabove.

Fig. 21 shows a cross-section of a chuck beam 208 in the position in which this remains until the box B has risen to press the ends of the lid L onto the ends of the box by forcing the lid ends upwardly against the lips 250, these lips being then lifted by the lid ends and pressed upwardly against the bottoms of the chuck beams 208. Up to this point the tension under which the springs 222 are maintained urges the chuck beams 208 into their lowermost positions on the side slide bars 190 as shown in Figs. 2, 20, and 21. When the lid ends have thus been completely pressed upon the box B, however, further continued upward movement of the box B lifts the chuck beams 208 so as to cause the drivers 206 to drive nails N from the recesses 232 downwardly from between the chuck springs 225 and 235 through the lid ends, and into the ends of the box as clearly shown in Fig. 22. In the embodiment disclosed, the nails N and drivers 206 do not move downwardly but remain stationary while the box and the lid are pushed upward onto the nails.

When the box B has been elevated to the position in which it is shown in Fig. 22 the release finger 218 on the chuck beam 208 of the nailing unit 189 (Figs. 3 and 3a) has been lifted to engage the head 377 on the safety shutoff rod 376, this engagement rocking the control shaft 360 so as to lift the pedal 372 against the action of the operator's foot and depress the eye 367 to neutralize the switch 343 and shut off the motor 65. When this occurs the operator releases the pedal 372, as shown in Fig. 4, this permitting the spring 374 to lift the rod 370 and thereby rock the shaft 360 to press the eye 367 downward and thus lower the stem 345 of the switch 343 to connect the conductors a, b, and c with the motor 65 through the reverse circuit Y'. The motor 65 is thus reversed and lowers the table 80 under power until the shut-off cam 165 engages the arm 363 to rock the shaft 360 against the action of the spring 374, neutralize the switch 343, and shut off the motor 65. Following the shutting off of the motor 65, the motor and the gear 67 continue to rotate owing to their momentum and are stopped by the gear housing brake 70 being forced downwardly by engagement therewith of the plungers 95, as clearly shown in Figs. 6 and 10. This halts rotation of the motor 65 and gear 67 with the table 80 returned to its original position.

As the table 80 descends the side flushers 110 return to their outward position shown in Fig. 6, this releasing the box from the longitudinal positioning cams 130 and swinging the downwardly extending arms 114 inwardly to lift the receiving end of the tiltable conveyor 140 into its elevated position, as shown in Figs. 3 and 13, and release the stop 153 (Figs. 12, 14, and 15) so that it will be free to rise up into the path of the next box to be received by the machine 35.

Owing to the inclination of the conveyor 140 on the table 80, the box B is now automatically discharged from this table by gravity onto the discharge conveyor 183. Descent of the table 80 also causes the stop 175 to be depressed as shown in Fig. 17, thus permitting box B' to be automatically fed onto the table 80 as the box B is discharged therefrom.

With the descent of the box B from its upwardmost position shown in Fig. 22, the chuck beams 208 descend to the positions indicated in Fig. 21, these being forced downwardly by the springs 222 to closely follow the box until the guide shoes 209 come into engagement with

the chuck beam stops 194 provided on the lower ends of the side slide bars 190. This reciprocation of the chuck beams 208 in each nailing operation accomplishes through the links 264 the oscillation of the nail hoppers 260 between downwardly inclined positions as shown in Figs. 21 and 23 and upwardly inclined positions as shown in Figs. 22 and 24.

A quantity of nails N are maintained in the hoppers 260 so that these are gradually fed into the slots 266 owing to the oscillation of the hoppers. The nails thus fed into the slots 266 slide downwardly in the slots beneath the transverse baffle walls 269 and 270 and the traps 274. Thus, when the hoppers 260 rock downwardly, as shown in Fig. 23, the traps 274 retain the nails which have passed under these traps from returning back into the hopper. A supply of nails is thus always maintained in the slots 266 adjacent the mouths thereof.

When the chuck beam 208 moves upwardly in each nailing operation, it not only tilts the hopper 260 upwardly, as shown in Fig. 24, but the roller 213 shown in Fig. 23 engages the picker operating cam lever 200 so as to shift the picker bar 281 into the position in which it is shown in Fig. 24. This causes a nail to be fed from the mouth of each of the slots 266 into the small picker bar notch 287 now disposed opposite this slot. As the hopper 260 starts to swing downwardly the roller 213 releases the lever 200 permitting the spring 286 to shift the picker bar 281 to its other position as shown in Fig. 23. This brings the notches 287 opposite the notches 268 in the front edge 267 of the floor 261 with this floor in downwardly inclined position as shown in Fig. 23. The nails N carried in the notches 287 are thus transferred to the notches 268. As the shifting of the picker bar 281 back to its nail receiving position starts before the hopper 260 has again been swung into its upwardly inclined position, the nails N thus delivered to the notches 268 remain in these notches when the picker bar 281 moves back to its position as shown in Fig. 24. Thus, with the upward swinging of the hoppers 260 the nails in the notches 268 are discharged therefrom through the large notches 288 and these nails fall downwardly into the nail funnels 237 with the latter positioned as shown in Fig. 22. Operating in this manner, the hoppers 260 deliver a single nail to each of the nail funnels 237 of each of the nailing units 188 and 189 during each nailing cycle.

The operation of the strapper 39 occurs simultaneously and automatically during the operation of the nailing mechanism 38. In describing this, reference is made to Figs. 2, 21, 22, 26, 27, 28, and 29. When the ends of box B engage the end tuckers 243 so as to lift these upwardly from the positions indicated in Fig. 21 to the positions indicated in Fig. 22, the arms 245 on these end tuckers are swung downwardly, thus pulling down on the links 334 and the arms 333 of the shaft 332 so as to rock this shaft and move the wedge 339 from the position in which it is shown in Fig. 26 to the position in which it is shown in Fig. 27. In this action the wedge 339 engages the roller 301 and lifts the strapper stem 299 and saddle bar 302 so that the springs 316 swing the drivers 313 about the pins 309. This movement is transmitted through the toggles 323 to the jaws 310 so that the latter are swung into substantially vertical positions as shown in Fig. 27. This action of the wedge 339 is thus seen to shape the ends of the strap S inwardly and bring the inner faces

of the jaws 310 into parallel relationship and spaced apart a distance approximately equal to the width of the box B. This inward swinging of the jaws 310 takes place just as the upper edges of the sides of the box B come opposite the lower portions of these jaws (Fig. 27), so that with further elevation of the box B the jaws slide vertically on the sides of the box. Owing to the box B being positioned between the jaws 310, these jaws cannot swing any further inwardly towards each other and the saddle bar 302 accordingly is not lifted by contact of the lid L therewith until the pressure between the lid and the saddle bar is sufficient to compress the springs 316. When the latter is accomplished, however, the cover has been shaped laterally to conform to the saddle bar 302, as shown in Fig. 28.

The final elevation of the box B to lift the chuck beams 208 and complete the nailing operation of the ends of the lid to the ends of the box B lifts the saddle bar 302 to bring the rollers 328 on the toggles 323 into engagement with the oblique faces 298 of the driver release cams 297, as shown in Fig. 28, and this contact throws the rollers 328 outwardly over dead center, thus releasing the drivers 313 from being locked to the jaws 310 by the toggles 323 and permitting the springs 316 to swing the drivers 313 suddenly inward, thus driving the pointed strap ends E into the sides of the box B and securing the ends of the strap S to the sides of the box, as shown in Fig. 29.

With the lowering of the table 80, the box B merely drops away from the strapper 39 and the strapper resumes the condition in which it is shown in Fig. 26 excepting for the fact that it is emptied of its strap.

It is noted that the crown sheet 341 is expansible vertically owing to the fact that its halves 340 are loosely connected to the strapper 39 (see Fig. 25) and the strapper 39 is yieldable vertically independently of the chuck beams 208 (see Figs. 26, 27, 28, and 29) to which the outer ends of the crown sheet are pivotally connected. It is preferable to limit this vertical expansibility of the crown sheet 341 and this is accomplished by the strapper limit bar 290 which connects the chuck beams 208. In the drawing box B is shown as having a pack of medium height. The height limit bar 290 is thus shown in Figs. 28 and 29 as disposed a considerable distance above the bottom of the slot 303 in the strapper 39 through which this bar extends. In the event a box with a pack of maximum height were to be strapped in the machine 35, the strapper 39 would be lifted so that the bottom of the slots 303 would engage the bar 290, thus limiting the upward extremity to which the center of the crown sheet could be lifted. This is for the purpose of preventing the arching of the lid L to the extent of drawing the ends of the lid inwardly from their proper positions over the ends of the box.

In the operation of the machine 35 the end tuckers and side flushers guard the edge rows of fruit in the superposed layer of oranges O' and makes special care by the operator for guarding these oranges almost unnecessary. However, the operator has complete control over the vertical movement of the table 80 at all times and is able by manipulation of the foot pedal 372 to either stop vertical movement of this table by neutralizing this pedal or by pressing the pedal down or entirely releasing it move the table 80 either upwardly or downwardly respectively.

When the lid L is forced upwardly by the 75

oranges O' against the crown sheet 341, side edge slats of the lid are brought into pressural engagement with the spreaders 342 so as to cause these spreaders to swing outwardly, spreading the side slats laterally as the cover is given its final shape by the crown sheet 341. The spreaders 342 are particularly effective in deflecting the side slats of the lid to a uniform height relative to the upper edges of the box sides in that the entire cover is engaged by the crown sheet 341 simultaneously with the spreading action of the spreaders 342. The spreaders 342 and crown sheet 341 represent an improvement upon the invention set forth in the application for U. S. Letters Patent, Serial No. 566,822, by Hale Paxton, filed October 3, 1931.

Our machine 35 is capable of nailing and strapping lids on boxes varying somewhat in size without adjustment of the machine. For instance, in the citrus industry "standard" and "jumbo" boxes of lemons are packed on the same floor out of the same lots of fruit, and it is of course desirable to nail and strap lids on these boxes as they are delivered in miscellaneous order from the packing tables to the lidded. The standard and jumbo boxes have the same length but vary in both height and width, although not greatly. Owing to the flexible character of the tucker spring arms 116 and the box centralizers 120 differences in width as much as an inch or more are automatically compensated for by the yielding of these elements. Differences in height between the jumbo and standard boxes are compensated for by the auxiliary blades 122, as clearly illustrated in Figs. 7 and 8, the box B representing a standard lemon box and box B' representing a jumbo box.

Orange shipping boxes and lemon shipping boxes differ slightly in length, but these boxes are seldom, if ever, delivered to the same lidding machine. Accordingly, automatic adjustability for length is not requisite in an automatic lidding machine used in the citrus industry. Accordingly, in the preferred embodiment of our invention illustrated herein we have provided the two pairs of holes 49 and 50 (Figs. 2, 3, and 4) for effecting the mounting of the nailing units 188 and 189 between the frame side plates 48 in either of two positions. When the machine 35 is installed in an orange house the nailing units 188 and 189 are mounted between the side plates 48 by extending the cap screws 193 through the holes 50 and then screwing these cap screws into the side slide bars 190. When the machine is to be used in a lemon house, however, the cap screws 193 are extended through the holes 49 and then into the side slide bars 190. While the change from one adjustment to the other is taking place the nailing units 188 and 189 are supported on the side plates 48 by the pins 191 (see Fig. 2). Obviously, strapper height limit bars 288 as well as crown sheet halves 340 and shafts 332 of different lengths are used when the machine is adjusted for lidding orange boxes than when the machine is adjusted for lidding lemon boxes.

It is also to be noted that the end rollers 134 (Figs. 4 and 12) of the table 80 are secured in place by cap screws 133 passing through holes 131 when the machine 35 is adjusted for lidding lemon boxes, and through holes 132 when adjusted for lidding orange boxes. The adjustment of rollers 134 results from the fact that the bottoms of citrus shipping boxes are quite thin so that to properly support the box ends these rollers must be located almost directly beneath these ends.

In Fig. 20 the springs 222 are shown as diagonally disposed so that as the chuck beam 208 is lifted and these springs compressed the angles of pressure of the springs against the chuck beam are materially reduced, this tending to equalize the pressure of the chuck beam 208 against the work during the lifting movement by reducing the portion of the spring pressure applied downwardly as the expansive force exerted by the springs along their own axes is increased. Where there is any difference in the resistance offered by the two springs 222, this is equalized by the rocking of the spring bracket 199 about the cap screw 201 connecting it to cross bar 196.

The collar 378 (Fig. 3) performs a safety function by virtue of its being positioned on the rod 376 so that this collar will be engaged by the finger 166 and will shut off the motor 65 before any damage is done to the machine in case the table 80 should be lifted without a box on it.

It is of course to be understood that reference to specific types of boxes is merely illustrative of the adaptability of this type of machine owing to the unique features of its construction. While we have shown and described but a single embodiment of our invention, it is to be understood that many changes and modifications might be made in this without departing from the spirit of the invention or the scope of the appended claims.

We claim as our invention:

1. In a nailing machine the combination of: nailing table means for supporting work to be nailed; a nailing unit including nail drivers and nail chucks, the latter being in alignment with and slidably disposed relative to said drivers; a frame upon which said table and unit are mounted, said frame including a positive drive mechanism for causing relative vertical movement between said table and said unit, said movement accomplishing the driving of nails into said work; an electric motor directly connected as a prime mover to said drive mechanism; and a control switch for energizing said motor to cause it to run in one direction or the other to relatively move said table and said unit towards or away from each other or for deenergizing said motor.

2. In a nailing machine the combination of: nailing table means for supporting work to be nailed; a nailing unit including nail drivers and nail chucks, the latter being in alignment with and slidably disposed relative to said drivers; a frame upon which said table and unit are mounted, said frame including positive drive mechanism for causing relative vertical movement between said table and said unit to drive nails into said work; an electric motor directly connected to said drive mechanism; a switch for energizing said motor to cause it to run in one direction or the other or to deenergize said motor; manually controlled switch operating means to cause said switch to energize said motor to effect relative movement of said table and said unit towards each other, said movement driving nails into said work; and means for automatically operating said switch to control said motor so as to discontinue said nail driving movement at the completion thereof.

3. In a nailing machine the combination of: nailing table means for supporting work to be nailed; a nailing unit including nail drivers and nail chucks, the latter being in alignment with and slidably disposed relative to said drivers; a frame upon which said table and unit are mounted, said frame including a positive drive mechanism for causing relative vertical movement between said table and said unit towards each

other, said movement accomplishing the driving of nails into said work; an electric motor directly connected to said drive mechanism; a switch for energizing said motor to cause it to run in one direction or the other or to deenergize said motor; means for operating said switch to energize said motor to effect relative movement of said table and said unit towards each other to drive nails into said work; means for operating said switch to reverse said motor, thereby causing relative movement of said table and said unit away from each other; and means for automatically operating said switch to deenergize said motor when said table and said unit are restored substantially to their normal spaced relationship.

4. In a nailing machine the combination of: nailing table means for supporting work to be nailed; a nailing unit including nail drivers and nail chucks, the latter being in alignment with and slidably disposed relative to said drivers; a frame upon which said table and unit are mounted, said frame including a positive drive mechanism for causing relative vertical movement between said table and said unit to drive nails into said work; an electric motor directly connected to said drive mechanism; a switch for energizing said motor to cause it to run in one direction or the other or to deenergize said motor; manually controlled switch operating means to cause said switch to energize said motor to effect relative movement of said table and said unit towards each other to drive nails into said work; means for automatically operating said switch to control said motor so as to discontinue said nail driving movement at the completion thereof; means for operating said switch to reverse said motor when said manual means is released, thereby causing relative movement of said table and said unit away from each other; and means for automatically operating said switch to deenergize said motor when said table and said unit are restored substantially to their normal spaced relationship.

5. In a nailing machine the combination of: nailing table means for supporting work to be nailed; a nailing unit including nail drivers and nail chucks, the latter being in alignment with and slidably disposed relative to said drivers; a frame upon which said table and unit are mounted, said frame including a positive drive mechanism for causing relative vertical movement between said table and said unit to drive nails into said work; an electric motor directly connected to said drive mechanism; a switch for energizing said motor to cause it to run in one direction or the other or to deenergize said motor; manually controlled switch operating means to cause said switch to energize said motor to effect relative movement of said table and said unit towards each other to drive nails into said work; means for automatically operating said switch to control said motor so as to discontinue said nail driving movement at the completion thereof; means for operating said switch to reverse said motor when said manual means is released, thereby causing relative movement of said table and said unit away from each other; means for automatically operating said switch to deenergize said motor when said table and said unit are restored substantially to their normal spaced relationship; and brake means for automatically braking the momentum of said motor and mechanism after said motor is deenergized by said last aforementioned means.

6. A combination as in claim 5 in which means is provided for automatically releasing said brake means following its operation as aforesaid and prior to a subsequent energizing of said motor to initiate another cycle of operation.

7. In a lid press the combination of: a table for receiving an overfilled packed box with a lid disposed thereover; overhead lid engaging means; a frame upon which said table and overhead means are mounted, said frame embodying a positive drive mechanism for causing reciprocating relative vertical movement between said table and said overhead means to bring the latter into contact with the ends of said lid, thus arching said lid over the overfilled contents of said box and pressing said lid ends onto the ends of said box in position for nailing thereto; an electric motor directly and continuously connected to said mechanism as prime mover thereof; a manually manipulative switch by which said motor may be caused to rotate in either direction or be shut off to effect said reciprocating movement; means constantly urging said switch to run said motor in a direction to separate said lid engaging means and said table; and means automatically actuating said switch at a given point in said separation to shut off said motor.

8. In a lid press the combination of: a table for receiving an overfilled packed box with a lid disposed thereover; overhead lid engaging means; a frame upon which said table and overhead means are mounted, said frame embodying a positive drive mechanism for causing reciprocating relative vertical movement between said table and said overhead means to bring the latter into contact with the ends of said lid, thus arching said lid over the overfilled contents of said box and pressing said lid ends onto the ends of said box in position for nailing thereto; an electric motor directly and continuously connected to said mechanism as prime mover thereof; a switch for causing said motor to rotate in either direction or to be shut off; a manual control for said switch which when manually actuated causes said switch to energize said motor to drive said mechanism to cause said table and lid engaging means to have relative movement towards each other, and which when manually released causes said switch to energize said motor to drive said mechanism to cause said table and lid engaging means to have relative movement away from each other; and means automatically actuating said switch to shut off said motor at the extremes of said relative movements.

9. In a lid nailing machine the combination of: a frame; a nailing table for receiving a packed box with a lid disposed thereover; means for centralizing said box on said table; a gear nut rotatively mounted on said frame on the vertical axis of said table; a screw provided on said table and screwed into said nut; an electric motor mounted on said frame; a pinion on the shaft of said motor, said pinion being continuously in mesh with said gear nut; nail chucks supported on said frame over opposite ends of said box and shiftable vertically; nail drivers on said frame disposed over and in vertical alignment with said chucks; a control switch for said motor; means for manually actuating said switch to energize said motor to elevate said table to lift said box and lid against said chucks and then lift said chucks to drive nails from said chucks through said lid and into said box; means automatically reversing said motor when said control switch is manually released; means automatically

neutralizing said switch when said table has been thus returned downwardly under power close to its lowermost position; and brake means automatically braking the rotation of said gear nut as said table approaches its lowermost position.

10. In a nailing machine the combination of: a rectangular base frame; posts rigidly fixed upon the corners of said base frame and extending upwardly therefrom; an overhead frame rigidly connecting the upper ends of said posts; nailing mechanism mounted on said overhead frame; a hollow standard provided on said base frame on the central vertical axis of said frame and extending upwardly therefrom; a thrust bearing formed on the upper end of said standard on said axis; a nut rotatable on said bearing; a jack screw screwed downwardly through said nut into said hollow standard; a rectangular work supporting nailing table rigidly mounted on the upper end of said screw, corners of said table being guided vertically on said posts; and an electric motor directly connected to said nut; and switch means for energizing said motor to positively rotate said nut successively in opposite directions to elevate and lower said table to accomplish a nailing operation.

11. In a lid nailing machine the combination of: a frame; a nailing table for receiving a packed box with a lid disposed thereover; means for centralizing said box on said table; a gear nut rotatively mounted on said frame on the vertical axis of said table; a screw provided on said table and screwed into said nut; an electric motor mounted on said frame; a pinion on the shaft of said motor, said pinion being continuously in mesh with said gear nut; nail chucks supported on said frame over opposite ends of said box and shiftable vertically; nail drivers on said frame disposed over and in vertical alignment with said chucks; a control switch for said motor; means for manually actuating said switch to energize said motor to elevate said table to lift said box and lid against said chucks and then lift said chucks to drive nails from said chucks through said lid and into said box; means automatically reversing said motor when said control switch is manually released; and means automatically neutralizing said switch when said table has been thus returned downwardly under power close to its lowermost position.

12. In a nailing machine the combination of: a rectangular base frame; posts rigidly fixed upon the corners of said base frame and extending upwardly therefrom; an overhead frame rigidly connecting upper ends of said posts; nailing mechanism mounted on said overhead frame; an elevator mechanism mounted on said base frame; a rectangular work supporting nailing table rigidly mounted on said elevator means, the corners of said table being guided vertically by said posts; means for operating said elevator mechanism to elevate and lower said table to accomplish a nailing operation; means on said table for positively centralizing work thereon relative to said nailing mechanism; and cam means on said posts for actuating said centralizing mechanism during the elevation of said table.

13. In a lid nailing machine for lidding overfilled packed boxes, the combination of: a frame including a base, posts extending upwardly therefrom, and a superstructure rigidly connecting the upper ends of said posts; nailing mechanism mounted on said superstructure and actuated by lifting a box thereagainst; an elevator mechanism mounted on said base; a nailing table

mounted on said elevator mechanism; means for operating said elevator mechanism to lift a box on said table with a lid disposed thereover against said nailing mechanism to press said cover on said box and nail the ends of said lid thereto; means mounted on said table for moving edge portions of an upper layer of produce in said box inwardly over said edges and maintaining said condition while said lid is being pressed on said box and nailed thereto; and cam means on said posts for actuating said produce moving means during the elevation of said table.

14. In a nailing machine the combination of: a frame including a base, posts extending upwardly therefrom, and a superstructure mounted on the upper ends of said posts; a pair of nailing units, each of which includes two vertical side slide bars, a cross-bar mounted on upper ends of said slide bars, a chuck beam disposed between and sliding at its ends on said slide bars, drivers mounted on said cross-bar and extending downwardly therefrom, and chucks provided on said chuck beam in alignment with said drivers; means on said superstructure for engaging said side slide bars to mount said nailing units spaced horizontally on said superstructure; a nailing table provided on said frame with its opposite ends positioned beneath said nailing units; and mechanism on said frame for causing relative vertical movement between said nailing units and said table to drive nails simultaneously in opposite ends of work on said table.

15. In a nailing machine the combination of: a frame including a base, posts extending upwardly therefrom, and a superstructure mounted on the upper ends of said posts; a pair of nailing units, each of which includes two vertical side slide bars, a cross-bar mounted on upper ends of said slide bars, a chuck beam disposed between and sliding at its ends on said slide bars, drivers mounted on said cross-bar and extending downwardly therefrom, and chucks provided on said chuck beam in alignment with said drivers; means on said superstructure for supporting said units by rigidly securing said side slide bars to said superstructure; a nailing table provided on said frame with its opposite ends positioned beneath said nailing units; and mechanism on said frame for elevating and lowering said table to cause said nailing units to drive nails simultaneously in opposite ends of work on said table.

16. In a nailing machine the combination of: a frame including a base, posts extending upwardly therefrom, and a superstructure mounted on the upper ends of said posts; a pair of nailing units, each of which includes two vertical side slide bars, a cross-bar mounted on upper ends of said slide bars, a chuck beam disposed between and sliding at its ends on said slide bars, drivers mounted on said cross-bar and extending downwardly therefrom, and chucks provided on said chuck beam in alignment with said drivers; means on said superstructure for supporting said units by rigidly securing said side slide bars to said superstructure yet permitting adjustment of said units towards or away from each other as units on said superstructure; a nailing table provided on said frame with its opposite ends positioned beneath said nailing units; and mechanism on said frame for elevating and lowering said table to cause said nailing units to drive nails simultaneously in opposite ends of work on said table.

17. In a nailing machine the combination of:

a frame including a base, posts extending upwardly therefrom, and a superstructure mounted on the upper ends of said posts; a pair of nailing units, each of which includes two vertical side slide bars, a cross-bar mounted on upper ends of said slide bars, a chuck beam disposed between and sliding at its ends on said slide bars, drivers mounted on said cross-bar and extending downwardly therefrom, and chucks provided on said chuck beam in alignment with said drivers; means on said superstructure for engaging said side slide bars to mount said nailing units on said superstructure, said mounting means permitting adjustment of said units toward and away from each other as units; a nailing table provided on said frame with its opposite ends positioned beneath said nailing units; and mechanism on said frame for causing relative vertical movement between said nailing units and said table to drive nails simultaneously in opposite ends of work on said table.

18. A combination as in claim 17 in which each of said units includes an oscillating nail hopper and a nail picker mounted on said unit.

19. In a nailing machine the combination of: a frame including a base, posts extending upwardly therefrom, and a superstructure mounted on the upper ends of said posts; a pair of nailing units, each of which includes two vertical side slide bars, a cross-bar mounted on upper ends of said side slide bars, a chuck beam disposed between said side slide bars and sliding at its ends thereon, drivers mounted on said cross-bar and extending downwardly therefrom, chucks provided on said chuck beam in alignment with said drivers, and an oscillating nail pan and a nail picker mounted on said unit; means on said superstructure for engaging said side slide bars to mount said units in spaced relation on said superstructure; a nailing table provided on said frame; and mechanism for causing relative vertical movement between said nailing units and said table to drive nails simultaneously in opposite ends of work on said table.

20. In a nailing machine the combination of: a rectangular base frame; posts rigidly fixed upon the corners of said base frame and extending upwardly therefrom; longitudinally disposed side plates connecting upper ends of said posts on each side of said machine; a pair of nailing units, each of which includes two vertical side slide bars, a cross-bar mounted on the upper ends of said slide bars, a chuck beam disposed between and sliding at its ends on said slide bars, drivers mounted on said cross-bar and extending downwardly therefrom, and chucks provided on said chuck beam in alignment with said drivers; means on said side plates for engaging said side slide bars to mount said nailing units in spaced relation with each other between said side plates; a nailing table provided on said frame with its opposite ends positioned beneath said nailing units; and mechanism for causing relative vertical movement between said nailing units and said table to drive nails simultaneously in opposite ends of work on said table.

21. In a nailing machine the combination of: a rectangular base frame; posts rigidly fixed upon the corners of said base frame and extending upwardly therefrom; longitudinally disposed side plates connecting upper ends of said posts on each side of said machine; a pair of nailing units, each of which includes two vertical side slide bars, a cross-bar mounted on the upper ends of said slide bars, a chuck beam dis-

posed between and sliding at its ends on said slide bars, drivers mounted on said cross-bar and extending downwardly therefrom, and chucks provided on said chuck beam in alignment with said drivers; means on said side plates for supporting said units by rigidly securing said side slide bars to said side plates; a nailing table having its corners guided vertically on said posts; and mechanism for elevating and lowering said table to cause said nailing units to drive nails simultaneously in opposite ends of work on said table.

22. In a nailing machine the combination of: a rectangular base frame; posts rigidly fixed upon the corners of said base frame and extending upwardly therefrom; longitudinally disposed side plates connecting upper ends of said posts on each side of said machine; a pair of nailing units, each of which includes two vertical side slide bars, a cross-bar mounted on the upper ends of said slide bars, a chuck beam disposed between and sliding at its ends on said slide bars, drivers mounted on said cross-bar and extending downwardly therefrom, and chucks provided on said chuck beam in alignment with said drivers; means on said side plates for supporting said units by rigidly securing said side slide bars to said side plates; means permitting adjustment of said units towards or away from each other on said plates as units; a rectangular nailing table having its corners guided vertically on said posts; and mechanism for elevating and lowering said table to cause said nailing units to drive nails simultaneously in opposite ends of work on said table.

23. In a lid nailing machine for lidding over-filled packed boxes, the combination of: a frame including a base, posts extending upwardly therefrom, and a superstructure mounted on the upper ends of said posts; a nailing table for receiving an over-filled packed box with a lid disposed thereover; a pair of nailing units, each of which includes two vertical side slide bars, a cross-bar mounted on the upper ends of said slide bars, a chuck beam disposed between and sliding at its ends on said slide bars, drivers mounted on said cross-bar and extending downwardly therefrom, chucks provided on said chuck beam in alignment with said drivers, and spring means normally under a substantial strain and urging said cross-bar and said chuck beam apart; means on said superstructure for engaging said side slide bars to mount said nailing units on said superstructure in spaced relation with each other; and mechanism on said frame for causing relative vertical movement between said nailing units and said table to bring said chuck beams into contact with opposite ends of said lid, said spring means yieldably pressing said chuck beams down to cause said contact to effect the arching of said lid over said superimposed contents of said box and the clamping of said lid ends against the ends of said box, said relative movement then continuing between said table and said cross-bars to cause said nail drivers to extend into said chucks to drive nails therefrom through said lid ends and into said box ends.

24. In a lid nailing machine for lidding over-filled packed boxes, the combination of: a nailing table for receiving an overfilled packed box with a lid disposed thereover; overhead nailing means including units, one of which units is disposed over each end of said lid, each of said units including nail drivers, a chuck beam slidable relative thereto, and yieldable means for holding said

drivers and said chuck beams in their maximum spaced relation with a substantial pressure; and means for supporting and causing relative vertical movement between said table and nail drivers to press said chuck beams against said lid ends, the force of said yieldable means substantially maintaining said maximum spaced relation between said drivers and chuck beams until said relative movement has caused said chuck beams to arch said cover over protruding contents of said box and spring said lid ends against ends of said box, said yieldable means then submitting to said relative movement to cause said chuck beams to have sliding movement on said nail drivers so that the latter drive nails from said chuck beams through said lid ends and into said box ends.

25. In a lid nailing machine for lidding overfilled packed boxes, the combination of: a nailing table for receiving an overfilled packed box with a lid disposed thereover; overhead nailing means including units, one of which units is disposed over each end of said lid, each of said units including nail drivers, a chuck beam slidable relative thereto, and yieldable means for holding said drivers and said chuck beams in their maximum spaced relation with a substantial pressure; means for supporting and causing relative vertical movement between said table and nail drivers to press said chuck beams against said lid ends, the force of said yieldable means substantially maintaining said maximum spaced relation between said drivers and chuck beams until said relative movement has caused said chuck beams to arch said cover over protruding contents of said box and spring said lid ends against ends of said box, said yieldable means then submitting to said relative movement to cause said chuck beams to have sliding movement on said nail drivers so that the latter drive nails from said chuck beams through said lid ends and into said box ends; and members yieldably mounted on said chuck beams to engage ends of said lid and move inwardly, as said lid ends approach said chuck beams, to centralize said lid longitudinally relative to said box as said lid is arched over said contents.

26. In a lid nailing machine for lidding overfilled packed boxes, the combination of: a nailing table for receiving an overfilled packed box with a lid disposed thereover; overhead nailing means including units, one of which units is disposed over each end of said lid, each of said units including nail drivers, a chuck beam slidable relative thereto, and yieldable means for holding said drivers and said chuck beams in their maximum spaced relation with a substantial pressure; means for supporting and causing relative vertical movement between said table and nail drivers to press said chuck beams against said lid ends, the force of said yieldable means substantially maintaining said maximum spaced relation between said drivers and chuck beams until said relative movement has caused said chuck beams to arch said cover over protruding contents of said box and spring said lid ends against ends of said box, said yieldable means then submitting to said relative movement to cause said chuck beams to have sliding movement on said nail drivers so that the latter drive nails from said chuck beams through said lid ends and into said box ends; and tucking means mounted on said chuck beams, said tucking means tucking portions of said contents inward as said lid ends are being pressed towards the ends of said box and then withdrawing from between said

lid ends and said box to permit the consummation of the lidding operation.

27. In a lid nailing machine for lidding overfilled packed boxes, the combination of: a nailing table for receiving an overfilled packed box with a lid disposed thereover; overhead nailing means including units, one of which units is disposed over each end of said lid, each of said units including nail drivers, a chuck beam slidable relative thereto, and yieldable means for holding said drivers and said chuck beams in their maximum spaced relation with a substantial pressure; means for supporting and causing relative vertical movement between said table and nail drivers to press said chuck beams against said lid ends, the force of said yieldable means substantially maintaining said maximum spaced relation between said drivers and chuck beams until said relative movement has caused said chuck beams to arch said cover over protruding contents of said box and spring said lid ends against ends of said box, said yieldable means then submitting to said relative movement to cause said chuck beams to have sliding movement on said nail drivers so that the latter drive nails from said chuck beams through said lid ends and into said box ends; tucking means mounted on said chuck beams, said tucking means tucking portions of said contents inward as said lid ends are being pressed towards the ends of said box and then withdrawing from between said lid ends and said box to permit the consummation of the lidding operation; and members yieldably mounted on said chuck beams to engage ends of said lid and yieldably hold said lid ends downwardly during said tucking action, said tucking means being actuated by said relative movement.

28. In a lid nailing machine for lidding overfilled packed boxes the combination of: a frame; a nailing table for receiving an overfilled packed box with a lid disposed thereover; nail drivers fixed on said frame above the ends of said box; nail chuck means disposed beneath and slidable up and down in alignment with said drivers; means for elevating said table to press the protruding contents of said box upward against said lid and thus lift the ends of said lid into pressural contact with said chuck means; and spring means interposed between said frame and said chuck means under a substantial strain for yieldably holding said chuck means down to cause said contact to effect the arching of said lid over said protruding contents of said box, and the clamping of said lid ends against the ends of said box before said chuck means are lifted by said elevating means to drive nails from said chuck means through said lid ends and into said box ends.

29. A combination as in claim 28 in which said springs are compression springs and are connected to said chuck means at points removed substantial distances from vertical alignment with the points at which said springs are attached to said frame.

30. In a lid nailing machine for lidding overfilled packed boxes the combination of: a frame; a nailing table for receiving an overfilled packed box with a lid disposed thereover; nail drivers mounted on opposite ends of said frame above the ends of said box; nail chuck means disposed beneath and slidable up and down in alignment with said drivers; means for yieldably pressing said chuck means downwardly; mechanism on said frame for lifting said table to bring the ends of said lid into pressural contact with said chuck

means, thereby forcing the ends of said lid against the ends of said box and then lifting said chuck means to drive nails therefrom through ends of said lid into ends of said box; and means disposed between and supported on said chuck means for defining the curvature of said lid when the latter responds to upward pressure of said fruit, said means then raising with said chuck means during said nailing operation.

31. A combination as in claim 30 in which said last recited means comprises a crown sheet which is swingably connected to said chuck means and also has a loose joint intermediate its ends; and means for pressing said crown sheet downwardly at said joint with a yieldable pressure.

32. In a lid press the combination of: a table for receiving an overfilled packed box with a lid disposed thereover; an overhead lid engaging crown sheet; a frame upon which said table and crown sheet are mounted, said frame embodying a mechanism for causing reciprocating relative vertical movement between said table and said crown sheet to bring the latter into contact with said lid, thus arching said lid over the overfilled contents of said box and pressing said lid ends onto the ends of said box in position for nailing thereto, said crown sheet having a loose joint intermediate its ends; and spring means tending to yieldably hold said crown sheet down at said joint, thus causing the curvature of said crown sheet to be adapted to varying heights of pack in said boxes without special adjustment thereof.

33. In a lid press the combination of: a table for receiving an overfilled packed box with a lid disposed thereover; an overhead lid engaging crown sheet; a frame upon which said table and crown sheet are mounted, said frame embodying a mechanism for causing reciprocating relative vertical movement between said table and said crown sheet to bring the latter into contact with said lid, thus arching said lid over the overfilled contents of said box and pressing said lid ends onto the ends of said box in position for nailing thereto; and a plurality of spreader dogs mounted on opposite sides of said crown sheet, said dogs being yieldable to yield laterally upon engaging side edge slats of said lid and thus spread said side slats laterally when said lid is shaped in substantial conformity with said crown sheet.

34. In a lid press the combination of: a table for supporting an overfilled packed box with a lid disposed thereover; overhead lid engaging means; a frame upon which said table and overhead means are mounted; means embodied in said frame for causing relative vertical movement of said table and overhead means to arch said lid over the protruding contents of said box and press ends of said lid onto ends of said box in readiness for nailing thereto; flusher means including flusher blades disposed at different levels; means for shifting said flusher means inward to move in an edge portion of said protruding contents; and means for rendering said flusher blades selectively operative according to the height of said box.

35. A combination as in claim 34 in which the lower of said flusher blades is yieldably supported so as to yield on engaging a wall of a box and permitting the upper of said blades to move in over said wall to perform said overflow moving operation.

36. In a lid nailing machine for lidding overfilled packed boxes the combination of: a frame; a nailing table supported on said frame for receiving an overfilled packed box; a pair of nail-

ing units mounted on said frame in spaced relation with each other over said nailing table, each of said units including a cross bar, a plurality of drivers mounted on said cross bar and extending downwardly therefrom, a chuck beam disposed beneath said cross bar, a plurality of nail chucks provided on said chuck beam in alignment with said drivers, means for supporting said cross bar on said frame, and means for supporting said chuck beam so as to be spaced downwardly from said cross bar and so as to be vertically slidable; mechanism on said frame for causing relative vertical movement between said nailing units and said table to bring said chuck beams into contact with opposite ends of a lid placed over said box until the opposite ends of said lid have been pressed against the opposite ends of said box, thereby arching said lid over the contents of said overfilled box, said relative movement then continuing between said table and said cross bars to cause said nail drivers to extend into said chucks to drive nails therefrom through said lid ends and into said box ends; and gathering means carried by said chuck beams for gathering produce inwardly from over vertical walls of said box to prevent said produce being pinched between said box and said lid.

37. In a lid nailing machine for lidding overfilled packed boxes, the combination of: a frame; a nailing table supported on said frame for receiving an overfilled packed box; a pair of nailing units mounted on said frame in spaced relation with each other over said nailing table, each of said units including a cross bar, a plurality of drivers mounted on said cross bar and extending downwardly therefrom, a chuck beam disposed beneath said cross bar, a plurality of nail chucks provided on said chuck beam in alignment with said drivers, means for supporting said cross bar on said frame, and means for supporting said chuck beam so as to be spaced downwardly from said cross bar and so as to be vertically slidable; mechanism on said frame for causing relative vertical movement between said nailing units and said table to bring said chuck beams into contact with opposite ends of a lid placed over said box until the opposite ends of said lid have been pressed against the opposite ends of said box, thereby arching said lid over the contents of said overfilled box, said relative movement then continuing between said table and said cross bar to cause said nail drivers to extend into said chucks to drive nails therefrom through said lid ends and into said box ends; and gathering means mounted on said chuck beams and moving inwardly automatically in timed relation with said lid pressing operation for gathering produce inwardly from over vertical walls of said box to prevent said produce being pinched between said box and said lid.

38. In a lid nailing machine for lidding overfilled packed boxes the combination of: a frame; a nailing table supported on said frame for receiving an overfilled packed box; a pair of nailing units mounted on said frame in spaced relation with each other over said nailing table, each of said units including a cross bar, a plurality of drivers mounted on said cross bar and extending downwardly therefrom, a chuck beam disposed beneath said cross bar, a plurality of nail chucks provided on said chuck beam in alignment with said drivers, means for supporting said cross bar on said frame, and means for supporting said chuck beam so as to be spaced downwardly from said cross bar and so as to be vertically slidable;

mechanism on said frame for causing relative vertical movement between said nailing units and said table to bring said chuck beams into contact with opposite ends of a lid placed over said box until the opposite ends of said lid have been pressed against the opposite ends of said box, thereby arching said lid over the contents of said overfilled box, said relative movement then continuing between said table and said cross bar to cause said nail drivers to extend into said chucks to drive nails therefrom through said lid ends and into said box ends; and tucking mechanism mounted on said chuck beams and automatically operated in timed relation with the lid pressing operation for tucking produce inwardly from between the ends of said box and the ends of said lid to prevent said produce from being pinched between said box and said lid.

39. In a lid nailing machine for lidding overfilled packed boxes the combination of: a frame; a nailing table supported on said frame for receiving an overfilled packed box; a pair of nailing units mounted on said frame in spaced relation with each other over said nailing table, each of said units including a cross bar, a plurality of drivers mounted on said cross bar and extending downwardly therefrom, a chuck beam disposed beneath said cross bar, a plurality of nail chucks provided on said chuck beam in alignment with said drivers, means for supporting said cross bar on said frame, and means for supporting said chuck beam so as to be spaced downwardly from said cross bar and so as to be vertically slidable; mechanism on said frame for elevating said table with a box resting thereon and a lid positioned over said box to force said lid and box upwardly against said chuck beams to spring the ends of said lid downwardly against the ends of said box thereby arching said lid over the contents of said box, the elevation of said table then continuing so as to lift said chuck beams and to cause said nail drivers to extend into said chucks to drive nails therefrom through said lid ends and into said box ends; and gathering means carried by said chuck beams and movable inwardly for gathering produce inward from over vertical walls of said box to prevent said produce being pinched between said box and said lid in said lid pressing operation, said gathering means then travelling upwardly with said chuck beams during the lid nailing operation.

40. In a lid nailing machine for lidding overfilled packed boxes, the combination of: a frame; a nailing table supported on said frame for receiving an overfilled packed box; a pair of nailing units mounted on said frame in spaced relation with each other over said nailing table, each of said units including a cross bar, a plurality of drivers mounted on said cross bar and extending downwardly therefrom, a chuck beam disposed beneath said cross bar, a plurality of nail chucks provided on said chuck beam in alignment with said drivers, means for supporting said cross bar on said frame, and means for supporting said chuck beam on said frame so as to be spaced downwardly from and vertically slidable relative to said cross bar; mechanism on said frame for elevating said table with a box resting thereon and a lid positioned over said box to force said lid and box upwardly against said chuck beams to spring the ends of said lid downwardly against the ends of said box thereby arching said lid over the contents of said box, the elevation of said table then continuing to lift said chuck beams and to cause said nail drivers to extend

into said chucks to drive nails therefrom through said lid ends and into said box ends; and gathering means mounted on said chuck beams and moving inwardly automatically in timed relation with said lid pressing operation for gathering produce inwardly from over vertical walls of said box to prevent said produce being pinched between said box and said lid.

41. In a lid nailing machine for lidding overfilled packed boxes, the combination of: a frame; a nailing table supported on said frame for receiving an overfilled packed box; a pair of nailing units mounted on said frame in spaced relation with each other over said nailing table, each of said units including a cross bar, a plurality of drivers mounted on said cross bar and extending downwardly therefrom, a chuck beam disposed beneath said cross bar, a plurality of nail chucks provided on said chuck beam in alignment with said drivers, means for supporting said cross bar on said frame, and means for supporting said chuck beam on said frame so as to be spaced downwardly from and vertically slidable relative to said cross bar; mechanism on said frame for elevating said table with a box resting thereon and a lid positioned over said box to force said lid and box upwardly against said chuck beams to spring the ends of said lid downwardly against the ends of said box thereby arching said lid over the contents of said box, the elevation of said table then continuing to lift said chuck beams and to cause said nail drivers to extend into said chucks to drive nails therefrom through said lid ends and into said box ends; and tucking mechanism mounted on said chuck beams and automatically operated in timed relation with the lid pressing operation for tucking produce inwardly from between the ends of said box and the ends of said lid to prevent said produce from being pinched between said box and said lid.

42. In a lid press, the combination of: a table for supporting an overfilled packed box with a lid disposed thereover; overhead lid engaging means; a frame upon which said table and overhead means are mounted; means for causing relative vertical movement of said table and overhead means to engage and arch said lid over the protruding contents of said box and press the ends of said lid over the ends of said box in readiness for nailing thereto; a primary flusher blade adapted for operation on a relatively tall box; a secondary flusher blade adapted for operation on a relatively low box; means for simultaneously moving said flusher blades inwardly relative to a box in said press; and yieldable means permitting said secondary blade to yield upon its engaging an outer face of a vertical wall of said tall box when the latter is disposed in said press, and permitting said flusher moving means to shift said primary flusher blade inwardly over said vertical wall of said tall box, said yieldable means being effective, when said low box is in said machine, to cause said secondary flusher blade to shift produce inward from over a vertical wall thereof when said blades are moved inwardly by said blade moving means.

43. In a lidding machine, the combination of: a frame; a nailing table for receiving loaded boxes to be lidded; a pair of nailing units mounted on said frame in spaced relation to each other over said nailing table, each of said units including a cross bar, a plurality of drivers mounted on said cross bar and extending downwardly therefrom, a chuck beam disposed beneath said cross bar, a plurality of nail chucks provided on said chuck

beam in alignment with said drivers, means for supporting said cross bar in a fixed position on said frame, means for supporting said chuck beam on said frame so as to be spaced downwardly from and vertically yieldable relative to said cross bar, a member pivotally mounted on a fixed horizontal axis parallel with said chuck beam, and links pivotally connected at their ends to corresponding ends of said beam and eccentric portions of said member; means for causing relative vertical movement between said nailing units and said table to bring said chuck beams into contact with opposite ends of said work, said relative movement then continuing between said table and said cross bars to cause said nail drivers to extend into said chucks to drive nails therefrom into said work.

44. In a lidding machine, the combination of: a frame; a nailing table for receiving loaded boxes to be lidded; a pair of nailing units mounted on said frame in spaced relation to each other over said nailing table, each of said units including a cross bar, a plurality of drivers mounted on said cross bar and extending downwardly therefrom, a chuck beam disposed beneath said cross bar, a plurality of nail chucks provided on said chuck beam in alignment with said drivers, means for supporting said cross bar in a relatively fixed position on said frame, means for supporting said chuck beam on said frame so as to be spaced downwardly from and vertically yieldable relative to said cross bar, a nail hopper pivotally mounted on said cross bar, and a pair of links the opposite ends of which are pivotally connected to opposite ends of said nail hopper and said chuck beam; means for causing relative vertical movement between said nailing units and said table to bring said chuck beams into contact with opposite ends of said work, said relative movement then continuing between said table and said cross bars to cause said nail drivers to extend into said chucks to drive nails therefrom into said work, said relative movement rocking said nail hoppers with each nailing operation.

45. In a nailing machine the combination of: nailing table means for supporting work to be nailed; a nailing unit including nail drivers and nail chucks, the latter being in alignment with and slidably disposed relative to said drivers; a frame upon which said table and unit are mounted, said frame including a positive drive mechanism for causing relative vertical movement between said table and said unit, said movement accomplishing the driving of nails into said work; an electric motor directly connected as a prime mover to said drive mechanism; and a control switch for energizing said motor to cause it to run in one direction or the other to decrease or increase the distance between said table and said unit or for deenergizing said motor; brake means automatically retarding and bringing to a standstill said drive mechanism and the armature of said motor upon the return of the normal spaced relation between said table and unit; and means for automatically actuating said control switch to deenergize said motor upon said normal spaced relationship being closely approached.

46. In a nailing machine the combination of: nailing table means for supporting work to be nailed; a nailing unit including nail drivers and nail chucks, the latter being in alignment with and slidably disposed relative to said drivers; a frame upon which said table and unit are mounted, said frame including a positive drive mechanism

for causing relative vertical movement between said table and said unit, said movement accomplishing the driving of nails into said work; an electric motor directly connected as a prime mover to said drive mechanism; and a control switch for energizing said motor to cause it to run in one direction or the other to decrease or increase the distance between said table and said unit or for deenergizing said motor; manual control means for freely manipulating said switch to cause said motor to run in such a direction as to decrease the distance between said table and said unit; and yieldable means automatically operating when said last aforementioned means is released to actuate said switch to cause said motor to run in the opposite direction to increase the distance between said table and said unit.

47. In a nailing machine the combination of: nailing table means for supporting work to be nailed; a nailing unit including nail drivers and nail chucks, the latter being in alignment with and slidably disposed relative to said drivers; a frame upon which said table and unit are mounted, said frame including a positive drive mechanism for causing relative vertical movement between said table and said unit, said movement accomplishing the driving of nails into said work; an electric motor directly connected as a prime mover to said drive mechanism; and a control switch for energizing said motor to cause it to run in one direction or the other to decrease or increase the distance between said table and said unit or for deenergizing said motor; manual control means for freely manipulating said switch to cause said motor to run in such a direction as to decrease the distance between said table and said unit; yieldable means automatically operating when said last aforementioned means is released to actuate said switch to cause said motor to run in the opposite direction to increase the distance between said table and said unit; and means automatically operating said switch to deenergize said motor when the normal spaced relationship between said table and said unit is substantially restored.

48. In a lid nailing machine for lidding overfilled packed boxes the combination of: a frame; a nailing table supported on said frame for receiving an overfilled packed box; a pair of nailing units mounted on said frame in spaced relation with each other over said nailing table, each of said units including a cross bar, a plurality of drivers mounted on said cross bar and extending downwardly therefrom, a chuck beam disposed beneath said cross bar, a plurality of nail chucks provided on said chuck beam in alignment with said drivers, means for supporting said cross bar on said frame, means for supporting said chuck beam on said frame so as to be spaced downwardly from and vertically slidably relative to said cross bar, spring means interposed between said cross bar and chuck beam, and members for transmitting the energy of said spring means to said chuck beam, said members having an angular relation with and being pivotally connected to opposite ends of said chuck beam; mechanism on said frame for causing relative vertical movement between said nailing units and said table to bring said chuck beams into contact with opposite ends of a lid placed over said box until the opposite ends of said lid have been pressed against the opposite ends of said box, thereby arching said lid over the contents of said overfilled box, said relative movement then continuing between said table and

said cross bar to cause said nail drivers to extend into said chucks to drive nails therefrom through said lid ends and into said box ends, said members being so related to said spring means in each of said units that as the chuck beam and cross bar of said unit move relatively toward each other, the angles between said members and said chuck beam decrease, thereby reducing the vertical resultant of the total pressure of said spring means applied to said chuck beam as the increasing distortion of said spring means increases said total pressure.

49. In a lid nailing machine for lidding overfilled packed boxes the combination of: a frame; a nailing table supported on said frame for receiving an overfilled packed box; a pair of nailing units mounted on said frame in spaced relation with each other over said nailing table, each of said units including a cross bar, a plurality of drivers mounted on said cross bar and extending downwardly therefrom, a chuck beam disposed beneath said cross bar, a plurality of nail chucks provided on said chuck beam in alignment with said drivers, means for supporting said cross bar on said frame, means for supporting said chuck beam on said frame so as to be spaced downwardly from and vertically slidable relative to said cross bar, spring means interposed between said cross bar and chuck beam, and members for transmitting the energy of said spring means to said chuck beam, said members having an angular relation with and being pivotally connected to opposite ends of said chuck beams; and mechanism on said frame for elevating said table with a box resting thereon and a lid positioned over said box to force said lid and box upwardly against the ends of said box thereby arching said lid over the contents of said box, the elevation of said table then continuing to lift said chuck beams and to cause said nail drivers to extend into said chucks to drive nails therefrom through said lid ends and into said box ends, said members being so related to said spring means in each of said units that as said chuck beams are lifted towards said cross bars, the angles between said members and said chuck beams decrease, thereby reducing the downward resultant of the total pressure of said spring means applied to said chuck beams as the increasing distortion of said spring means increases said total pressure.

50. In a lid nailing machine for lidding overfilled packed boxes, the combination of: a frame; a nailing table supported on said frame for receiving an overfilled packed box; a pair of nailing units mounted on said frame in spaced relation with each other over said nailing table, each of said units including a cross bar, a plurality of drivers mounted on said cross bar and extending downwardly therefrom, a chuck beam disposed beneath said cross bar, a plurality of nail chucks provided on said chuck beam in alignment with said drivers, means for supporting said cross bar on said frame, means for supporting said chuck beam on said frame so as to be spaced downwardly from and vertically slidable relative to said cross bar, spring means, and spring mounting means for placing said spring means under pressure and applying a fraction of the total pressure of said spring means in urging said bar and beam apart; mechanism on said frame for causing relative vertical movement between said nailing units and said table to bring said chuck beams into contact with opposite ends of a lid placed over said box until the opposite ends of said lid have been pressed against the opposite

ends of said box, thereby arching said lid over the contents of said overfilled box, said relative movement then continuing between said table and said cross bar to cause said nail drivers to extend into said chucks to drive nails therefrom through said lid ends and into said box ends; said spring mounting means applying a smaller fraction of the total pressure exerted by said spring means in urging said cross bars and chuck beams apart as the relative movement of said bars and beams towards each other increases the distortion of said spring means and accordingly the total pressure exerted by said spring means.

51. In combination: a frame; a table supported on said frame for receiving an overfilled packed box; a driver supported on said frame above said table, said driver being adapted to drive a securing element into said box; a pressure beam adapted to press downwardly on the cover of said box; means on said beam for guiding said securing element, said beam being vertically slidable relative to said driver; mechanism on said frame causing relative vertical movement between said table and said driver and said beam to first apply said beam pressurably to said cover and then cause said driver to perform its driving function as aforesaid; spring means; and spring mounting means for placing said spring means under pressure and utilizing a fraction of the total pressure of said spring means in urging said driver and said beam apart, said last mentioned means applying a smaller fraction of the total pressure exerted by said spring means in urging said driver and said beam apart as the contact of said cover with said beam results in relative movement towards each other of said driver and said beam, the latter action increasing the distortion of said spring means and accordingly the total pressure exerted by the latter.

52. In a lid nailing machine for lidding overfilled packed boxes, the combination of: a frame; a nailing table supported on said frame for receiving an overfilled packed box; a pair of nailing units mounted on said frame in spaced relation with each other over said nailing table, each of said units including a cross bar, a plurality of drivers mounted on said cross bar and extending downwardly therefrom, a chuck beam disposed beneath said cross bar, a plurality of nail chucks provided on said chuck beams in alignment with said drivers, means for supporting said cross bar on said frame, means for supporting said chuck beam on said frame so as to be spaced downwardly from and vertically slidable relative to said cross bar, spring means, and spring mounting means for carrying said spring means and applying equal portions of the pressure exerted by said spring means to opposite end portions of said beams to urge said bar and beam apart; mechanism on said frame for causing relative vertical movement between said nailing units and said table to bring said chuck beams into contact with opposite ends of a lid placed over said box until the opposite ends of said lid have been pressed against the opposite ends of said box, thereby arching said lid over the contents of said overfilled box, said relative movement then continuing between said table and said cross bar to cause said nail drivers to extend into said chucks to drive nails therefrom through said lid ends and into said box ends, said spring mounting means maintaining the equality of said portions of said spring pressure applied to opposite end portions of said beams as

the relative movement of said bars and beams towards each other increases the distortion of said spring means and accordingly the total pressure exerted by said spring means.

53. A combination as in claim 50 in which said spring mounting means applies equal portions of the pressure exerted by said spring means to opposite portions of said beam in each of said units and maintains the equality of said portions during the relative movement of said bars and beams toward each other.

54. In a nailing machine the combination of: nailing table means for supporting work to be nailed; a nailing unit including nail drivers and nail chucks, the latter being in alignment with and slidably disposed relative to said drivers; a frame upon which said table and unit are mounted, said frame including a positive drive mechanism for causing relative vertical movement between said table and said unit, said movement accomplishing the driving of nails into said work; an electric motor directly connected as a prime mover to said drive mechanism; and a control switch for energizing said motor to cause it to run in one direction or the other to decrease or increase respectively the vertical distance between said table and said unit or for deenergizing said motor; brake means automatically retarding and bringing to a standstill said drive mechanism and the armature of said motor upon the return of said table and unit to their normal spaced relationship; means for automatically actuating said control switch to deenergize said motor as the normal spaced relationship between said table and said unit is approached; and means rendering said brake means ineffective to retard said drive mechanism at the initiation of a subsequent cycle of operation of said machine.

55. In a nailing machine the combination of: nailing table means for supporting work to be nailed; a nailing unit including nail drivers and nail chucks, the latter being in alignment with and slidably disposed relative to said drivers; a frame upon which said table and unit are mounted, said frame including a positive drive mechanism for causing relative vertical movement between said table and said unit, said movement accomplishing the driving of nails into said work; an electric motor directly connected as a prime mover to said drive mechanism; and a control switch for selectively energizing said motor and thereby permitting the operator to manipulate at will the spaced relation of said unit and said table by running said motor in a direction to reduce the vertical space between said unit and said table or to run said motor in a reverse direction to increase the vertical space between said unit and table.

56. In a nailing machine the combination of: nailing table means for supporting work to be nailed; a nailing unit including nail drivers and nail chucks, the latter being in alignment with and slidably disposed relative to said drivers; a frame upon which said table and unit are mounted, said frame including a positive drive mechanism for causing relative vertical movement between said table and said unit, said movement accomplishing the driving of nails into said work; an electric motor directly connected as a prime mover to said drive mechanism; a control switch for energizing said motor to cause it to run in one direction or the other to decrease or increase the vertical space between said table and said unit or for deenergizing said motor; and safety

means operable in the absence of any work upon said table for automatically actuating said switch to discontinue the running of said motor in a direction to decrease said vertical space, said safety means functioning as aforesaid upon the attaining of a given minimum spaced relationship between said table and said nail chucks.

57. In a nailing machine the combination of: nailing table; means for supporting work to be nailed; a nailing unit including nail drivers and nail chucks, the latter being in alignment with and slidably disposed relative to said drivers; a frame upon which said table and unit are mounted; elevating means on said frame for causing movement of said table towards and away from said unit, said movement of said table accomplishing the driving of nails by said drivers from said nail chucks into said work; an electric motor directly connected as a prime mover to said elevating means; and a control switch for energizing said motor to cause it to run under power in one direction or the other to cause said table to move towards or away from said unit or for deenergizing said motor.

58. In a nailing machine the combination of: nailing table; means for supporting work to be nailed; a nailing unit including nail drivers and nail chucks, the latter being in alignment with and slidably disposed relative to said drivers; a frame upon which said table and unit are mounted; elevating means on said frame for causing movement of said table towards and away from said unit, said movement of said table accomplishing the driving of nails by said drivers from said nail chucks into said work; an electric motor directly connected as a prime mover to said elevating means; a control switch for energizing said motor to cause it to run under power in one direction or the other to cause said table to move towards or away from said unit or for deenergizing said motor; and safety means operable in the absence of any work upon said table for automatically actuating said switch to discontinue the running of said motor in a direction to lift said table, said safety means functioning as aforesaid upon the attaining of a given minimum spaced relationship between said table and said nail chucks.

59. In a lidding machine, the combination of: a frame; a nailing table for receiving loaded boxes to be lidded; a pair of nailing units mounted on said frame in spaced relation to each other over said nailing table, each of said units including a cross bar, a plurality of drivers mounted on said cross bar and extending downwardly therefrom, a chuck beam disposed beneath said cross bar, a plurality of nail chucks provided on said chuck beam in alignment with said drivers, means for supporting said chuck beam on said frame so as to be spaced downwardly from and vertically yieldable relative to said cross bar, two pairs of elements those in each pair being pivotally connected together, one element in each pair being pivotally connected to said cross bar and the other element in said pair being pivotally connected to said chuck beam, and means for applying a yieldable pressure to said pairs of elements tending to separate said elements and to urge said bar and chuck beam apart; and means for causing relative vertical movement between said nailing units and said table to bring about contact of said chuck beams with opposite ends of said work, said relative movement then continuing between said table and said cross bars to

cause said nail drivers to extend into said chucks to drive nails therefrom into said work.

60. In a box lidding machine, means for supporting a box to be lidded, means disposed above
5 said box supporting means for applying lids to boxes, means mounting said box supporting means for movement between a lowermost position and an elevated position, a power shaft,
10 means connecting said power shaft to said supporting means to elevate said box supporting means when said power shaft is moved in one direction and to lower said box supporting means when said shaft is moved in the opposite direction, reversible power means for driving said
15 power shaft, brake means for said power means, means normally urging said brake means out of braking relation with said power means, and means operated by the approach of said box supporting means to its lowermost position for applying said braking means.

61. In a box lidding machine, means for supporting a box to be lidded, means disposed above
25 said box supporting means for applying lids to boxes, means mounting said box supporting means for movement between a lowermost position and an elevated position, a power shaft, means connecting said power shaft to said box supporting means to move said box supporting
30 means between its lowermost position and its uppermost position, brake means for retarding movement of said power shaft, including a brake shoe normally urged away from braking position, and means operable by the approach of said box supporting means to its lowermost position for
35 moving said brake shoe to braking position.

62. In a box lidding machine, means for supporting a box to be lidded, means disposed above
40 said box supporting means for applying a lid to said box, means mounting said box supporting means for movement between a lowermost position and an elevated position, a power shaft, means connecting said power shaft to said box supporting means to move said box supporting

means between its lowermost position and its uppermost position, brake means for retarding movement of said power shaft, and means automatically operable by the approach of said box supporting means to its lowermost position for
5 rendering said brake means operative.

63. In a box lidding machine, means for supporting a box to be lidded, means disposed above
10 said box supporting means for applying a lid to said box, means mounting said box supporting means for movement between a lowermost position and an elevated position, a power shaft, means connecting said power shaft to said box supporting means to move said box supporting
15 means between its lowermost position and its uppermost position, brake means for retarding movement of said power shaft, means automatically operable by the approach of said box supporting means to its lowermost position for rendering said brake means operative, and means
20 automatically effective to cause said brake means to be inoperative when the next upward movement of said box supporting means is commenced.

64. A combination as in claim 3 having a brake
25 means which is automatically operative to retard the movement of said drive mechanism and said motor as the normal spaced relationship between said table and said unit is approached in the
30 operation of said machine.

65. A combination as in claim 3 having a brake
35 means which is automatically operative to retard the movement of said drive mechanism and said motor as the normal spaced relationship between said table and said unit is approached in the operation of said machine, said brake means embodying means for rendering said brake means inoperative to retard movement of said drive mechanism and motor when the next nailing
40 operation is commenced.

HALE PAXTON.
GERALD C. PAXTON.
HARRY D. BENSON.