

(19) World Intellectual Property Organization
International Bureau



(43) International Publication Date
13 November 2008 (13.11.2008)

PCT

(10) International Publication Number
WO 2008/137679 A1

(51) International Patent Classification:
H02M 3/156 (2006.01)

(21) International Application Number:
PCT/US2008/062423

(22) International Filing Date: 2 May 2008 (02.05.2008)

(25) Filing Language: English

(26) Publication Language: English

(30) Priority Data:
60/915,547 2 May 2007 (02.05.2007) US

(71) Applicant (for all designated States except US): CIRRUS LOGICS, INC. [US/US]; 2901 Via Fortuna, Austin, TX 78746 (US).

(72) Inventor: MELANSON, John, L.; 901 W. 9th Street, #201, Austin, TX 78703 (US).

(74) Agent: CHAMBERS, Kent, B.; Hamilton & Terrile, LLP, P.O. Box 203518, Austin, TX 78720 (US).

(81) Designated States (unless otherwise indicated, for every kind of national protection available): AE, AG, AL, AM, AO, AT, AU, AZ, BA, BB, BG, BH, BR, BW, BY, BZ, CA, CH, CN, CO, CR, CU, CZ, DE, DK, DM, DO, DZ, EC, EE, EG, ES, FI, GB, GD, GE, GH, GM, GT, HN, HR, HU, ID, IL, IN, IS, JP, KE, KG, KM, KN, KP, KR, KZ, LA, LC, LK, LR, LS, LT, LU, LY, MA, MD, ME, MG, MK, MN, MW, MX, MY, MZ, NA, NG, NI, NO, NZ, OM, PG, PH, PL, PT, RO, RS, RU, SC, SD, SE, SG, SK, SL, SM, SV, SY, TJ, TM, TN, TR, TT, TZ, UA, UG, US, UZ, VC, VN, ZA, ZM, ZW.

(84) Designated States (unless otherwise indicated, for every kind of regional protection available): ARIPO (BW, GH, GM, KE, LS, MW, MZ, NA, SD, SL, SZ, TZ, UG, ZM, ZW), Eurasian (AM, AZ, BY, KG, KZ, MD, RU, TJ, TM), European (AT, BE, BG, CH, CY, CZ, DE, DK, EE, ES, FI, FR, GB, GR, HR, HU, IE, IS, IT, LT, LU, LV, MC, MT, NL, NO, PL, PT, RO, SE, SI, SK, TR), OAPI (BF, BJ, CF, CG, CI, CM, GA, GN, GQ, GW, ML, MR, NE, SN, TD, TG).

Published:
— with international search report

(54) Title: SWITCHING POWER CONVERTER WITH SWITCH CONTROL PULSE WIDTH VARIABILITY AT LOW POWER DEMAND LEVELS

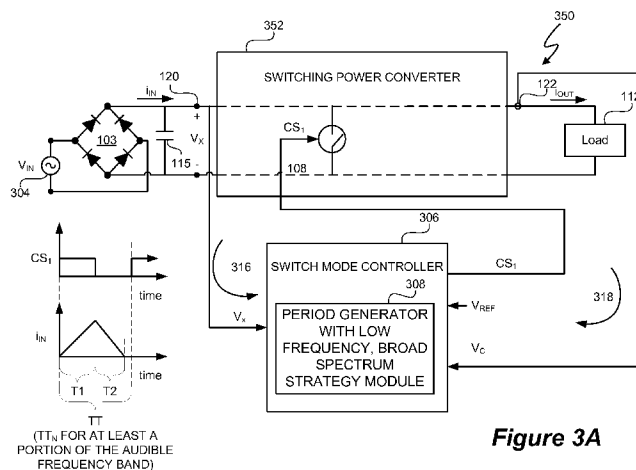

Figure 3A

(57) Abstract: A power control system includes a switch mode controller (306) to control the switching mode of a switching power converter (352). The switch mode controller (306) generates a switch control signal (CSI) that controls conductivity of a switch (108) of the switching power converter (352). Controlling conductivity of the switch (108) controls the switch mode of the switching power converter (352). The switch mode controller (306) includes a period generator (308) to determine a period of the switch control signal (CSI) and to vary the determined period to generate a broad frequency spectrum of the switch control signal (CSI) when the determined period corresponds with a frequency in at least a portion of an audible frequency band. Generating a switch control signal with a broad frequency spectrum in the audible frequency band allows the system to utilize switching frequencies in the audible frequency band.



WO 2008/137679 A1

**SWITCHING POWER CONVERTER WITH SWITCH CONTROL PULSE
WIDTH VARIABILITY AT LOW POWER DEMAND LEVELS**

John L. Melanson

Cross-reference to Related Application

(1) This application claims the benefit under 35 U.S.C. § 119(e) and 37 C.F.R. § 1.78 of U.S. Provisional Application No. 60/915,547, filed on May 2, 2007 and entitled “Power Factor Correction (PFC) Controller Apparatuses and Methods”.

BACKGROUND OF THE INVENTION

Field of the Invention

(2) The present invention relates in general to the field of electronics, and more specifically to a system and method for voltage conversion using a switching power converter with variations of a switch control signal pulse widths at low power demand levels.

DESCRIPTION OF THE RELATED ART

(3) Many devices utilize electrical power to operate. Power is initially supplied by a power source, such as a public utility company, and power sources generally provide a steady state input voltage. However, the voltage levels utilized by various devices may differ from the steady state input voltage provided by the power source. For example, light emitting diode (LED) based lighting systems, typically operate from voltage levels that differ from voltage level supplied by a public utility company. To accommodate the difference between the voltage from the power source and the voltage utilized by the device, power converters are connected between the power source and the device to convert a supply voltage level from an alternating current (AC) power source to, for example, another AC power source having a voltage level different than the supply voltage level. Power converters can also convert AC power into direct (DC) power and DC power into AC power.

(4) Switching power converters represent one example of a type of power converter. A switching power converter utilizes switching and energy storage technology to convert an input voltage into an output voltage suitable for use by a particular device connected to the switching power converter.

(5) Figure 1 depicts a power control system 100, which includes a switching power converter 102. Voltage source 101 supplies an AC input “mains” voltage V_{mains} to a full, diode bridge rectifier 103. The voltage source 101 is, for example, a public utility, and the AC mains voltage V_{mains} is, for example, a 60 Hz/120 V mains voltage in the United States of America or a 50 Hz/230 V mains voltage in Europe. The rectifier 103 rectifies the input mains voltage V_{mains} . The rectifier 103 rectifies the input mains voltage V_{mains} and supplies a rectified, time-varying, primary supply voltage V_X to the switching power converter. The switching power converter 102 provides approximately constant voltage power to load 112 while maintaining a resistive input characteristic to voltage source 101. Providing approximately constant voltage power to load 112 while maintaining an approximately resistive input characteristic to voltage source 101 is referred to as power factor correction (PFC). Thus, a power factor corrected switching power converter 102 is controlled so that an input current i_L to the switching power converter 102 varies in approximate proportion to the AC mains voltage V_{mains} .

(6) PFC and output voltage controller 114 controls the conductivity of switch mode switch 108 so as to provide power factor correction and to regulate the output voltage V_C of switching power converter 102. The PFC and output voltage controller 114 attempts to control the inductor current i_L so that the average inductor current i_L is linearly and directly proportional to the primary supply voltage V_X . A proportionality constant relates the inductor current i_L to the primary supply voltage V_X , and the proportionality constant is adjusted to regulate the voltage to load 112. The PFC and output voltage controller 114 supplies a pulse width modulated (PWM) switch control signal CS_0 to control the conductivity of switch 108. In at least one embodiment, switch 108 is a field effect transistor (FET), and switch control signal CS_0 is the gate voltage of switch 108. The values of the pulse width and duty cycle of switch control signal CS_0 depend on at least two signals, namely, the primary supply voltage V_X and the capacitor voltage/output voltage V_C . Output voltage V_C is also commonly

referred to as a “link voltage”. Current control loop 119 provides current i_{RTN} to PFC and output voltage controller 114 to allow PFC and output voltage controller 114 to adjust an average i_L current to equal a target i_L current.

(7) Capacitor 106 supplies stored energy to load 112 when diode 111 is reverse biased and when the primary supply voltage V_X is below the RMS value of the input mains. The value of capacitor 106 is a matter of design choice and, in at least one embodiment, is sufficiently large so as to maintain a substantially constant output voltage V_C , as established by a PFC and output voltage controller 114. A typical value for capacitor 106, when used with a 400 V output voltage V_C , is 1 microfarad per watt of maximum output power supplied via switching power converter 102. The output voltage V_C remains at a substantially constant target value during constant load conditions with ripple at the frequency of primary supply voltage V_X . However, as load conditions change, the output voltage V_C changes. The PFC and output voltage controller 114 responds to the changes in voltage V_C by adjusting the switch control signal CS_0 to return the output voltage V_C to the target value. In at least one embodiment, the PFC and output voltage controller 114 includes a small capacitor 115 to filter any high frequency signals from the primary supply voltage V_X .

(8) The switching power converter 102 incurs switching losses each time switch 108 switches between nonconductive and conductive states due to parasitic impedances. The parasitic impedances include a parasitic capacitance 132 across switch 108. During each period TT of switching switch control signal CS_0 , energy is used to, for example, charge parasitic capacitance 132. Thus, switching power converter 102 incurs switching losses during each period TT of switch control signal CS_0 .

(9) PFC and output voltage controller 114 controls the process of switching power converter 102 so that a desired amount of energy is transferred to capacitor 106. The desired amount of energy depends upon the voltage and current requirements of load 112. To determine the amount of energy demand of load 112, the PFC and output voltage controller 114 includes a compensator 128. An input voltage control loop 116 provides a sample of primary supply voltage V_X to PFC and output voltage controller 114. Compensator 128 determines a difference between a reference voltage V_{REF} , which indicates a target voltage for output voltage V_C , and the actual output voltage V_C sensed from node 122 and received as feedback from voltage loop 118. The

compensator 128 generally utilizes technology, such as proportional integral (PI) type control, to respond to differences in the output voltage V_C relative to the reference voltage V_{REF} . The PI control processes the error so that the PFC and output voltage controller 114 smoothly adjusts the output voltage V_C to avoid causing rapid fluctuations in the output voltage V_C in response to small error signals. The compensator 128 provides an output signal to the pulse width modulator (PWM) 130 to cause the PWM 130 to generate a switch control signal CS_0 that drives switch 108.

(10) PFC and output voltage controller 114 modulates the conductivity of PFC switch 108. The primary supply voltage V_X is, in at least one embodiment, a rectified sine wave. To regulate the amount of energy transferred and maintain a power factor close to one, PFC and output voltage controller 114 varies the period TT of switch control signal CS_0 so that the inductor current i_L (also referred to as the 'input current') tracks changes in primary supply voltage V_X and holds the output voltage V_C constant. As the primary supply voltage V_X increases from phase angle 0° to phase angle 90° , PFC and output voltage controller 114 increases the period TT of switch control signal CS_0 , and as the primary supply voltage V_X decreases, PFC and output voltage controller 114 decreases the period of switch control signal CS_0 .

(11) Time T_2 represents a flyback time of inductor 110 that occurs when switch 108 is nonconductive and the diode 111 is conductive. In at least one embodiment, the value of inductor 110 is a matter of design choice. Inductor 110 can be any type of magnetic component including a transformer. In at least one embodiment, the value of inductor 110 is chosen to store sufficient power transferred from voltage source 101 when switch 108 conducts in order to transfer energy to capacitor 106 when switch 108 is non-conductive to maintain a desired output voltage V_C .

(12) The inductor current i_L ramps 'up' during time T_1 when the switch 108 conducts, i.e. is "ON". The inductor current i_L ramps down during flyback time T_2 when switch 108 is nonconductive, i.e. is "OFF", and supplies inductor current i_L through diode 111 to recharge capacitor 106. Discontinuous conduction mode (DCM) occurs when the inductor current i_L reaches 0 during the period TT of switch control signal CS_0 . Continuous conduction mode (CCM) occurs when the inductor current i_L is greater than 0 during the entire period TT .

(13) The PFC and output voltage controller 114 sets a target current that tracks the primary supply voltage V_X . When the inductor current i_L reaches the target current during the pulse width T1, the switch control signal CS_0 opens switch 108, and inductor current i_L decreases to zero during flyback time T2. An average inductor current i_L tracks the primary supply voltage V_X , thus, providing power factor correction. Prodić, *Compensator Design and Stability Assessment for Fast Voltage Loops of Power Factor Correction Rectifiers*, IEEE Transactions on Power Electronics, Vol. 12, No. 5, Sept. 1007, pp. 1719-1729 (referred to herein as “Prodić”), describes an example of PFC and output voltage controller 114.

(14) PFC and output voltage controller 114 updates the switch control signal CS_0 at a frequency much greater than the frequency of input voltage V_X . The frequency of input voltage V_X is generally 50-60 Hz. The frequency $1/TT$ of switch control signal CS_0 is, for example, at or below 130 kHz to avoid significant switching inefficiencies.

(15) Figure 2 depicts a human audible sensitivity versus audible frequency band graph 200. The audible sensitivity plot 202 indicates the relationship between sound frequencies and human sensitivity to the sounds. References to “humans” refer to typical humans. Generally, humans can hear sounds having frequencies ranging from about 20 Hz to about 20 kHz. Thus, the audible frequency band is defined as approximately 20 Hz to 20 kHz. Human sensitivity to sound increases as the frequency increases from 20 Hz to about 1 kHz. At about 1 kHz, human sensitivity to sounds begins to decline as the sound frequency increases. Human sensitivity declines to 0 to sounds above about 20 kHz. In other words, sounds above about 20 kHz are generally inaudible to humans.

(16) Humans are particularly sensitive to tones, such as tone 204, with frequencies in the audible frequency band. Human audible tones are repetitive sounds with a fundamental frequency in the audible frequency band. Humans are less sensitive to non-tonal, or noise-like sounds.

(17) Referring to Figures 1 and 2, all magnetic circuit components of power control system 100 are small speakers. Physical forces on the wires and magnetic circuit components of power control system 100 cause the wires and components to vibrate at the switching frequency of switch control signal CS_0 . Switching frequencies below

20 kHz can produce audible tones that are generally deemed undesirable. Since the power demand by load 112 tends to change very little over a short period of time, such as 2-4 seconds, the frequency of switch control signal CS₀ would remain approximately constant and produce an audible tone for switching frequencies less than 20 kHz.

(18) Lower switching frequencies of switch control signal CS₀ are generally desirable. High voltage transistors, diodes, and inductors often have significant parasitic capacitances that make high frequency switching of switch 108 inefficient. Additionally, high frequency switching increases electromagnetic interference (EMI) of power control system 100. Although lower switching frequencies are desirable, power control system 100 typically avoids switching frequencies below 20 kHz to avoid generating audible tones. Thus, the production of tones by power control system 100 limits the switching frequency range of switch 108.

SUMMARY OF THE INVENTION

(19) In one embodiment of the present invention, a system includes a switch mode controller to generate a switch control signal to control conductivity of a switching mode switch included in a switching power converter. The switch mode controller includes a period generator to determine a nominal period of the switch control signal and to vary the nominal period to generate a broad frequency spectrum of the switch control signal when the nominal period corresponds with a frequency in at least a portion of an audible frequency band.

(20) In another embodiment of the present invention, a method includes generating a switch control signal to control conductivity of a switch mode switch included in a switching power converter. The method also includes determining a nominal period of the switch control signal and varying the nominal period to generate a broad frequency spectrum of the switch control signal when the nominal period corresponds with a frequency in at least a portion of an audible frequency band. The method further includes determining a pulse width of the switch control signal and providing the switch control signal to the switch of the switching power converter.

(21) In a further embodiment of the present invention, a power control system includes a switching power converter having a switch and a switch mode controller to

generate a switch control signal to control conductivity of a switching mode switch included in a switching power converter. The switch mode controller includes a period generator to determine a nominal period of the switch control signal and to vary the nominal period to generate a broad frequency spectrum of the switch control signal when the nominal period corresponds with a frequency in at least a portion of an audible frequency band.

(22) In another embodiment of the present invention, an apparatus includes means for generating a switch control signal to control conductivity of a switch mode switch included in a switching power converter. The apparatus further includes means for determining a nominal period of the switch control signal and means for varying the nominal period to generate a broad frequency spectrum of the switch control signal when the nominal period corresponds with a frequency in at least a portion of an audible frequency band. The apparatus also includes means for determining a pulse width of the switch control signal and means for providing the switch control signal to the switch of the switching power converter.

BRIEF DESCRIPTION OF THE DRAWINGS

(23) The present invention may be better understood, and its numerous objects, features and advantages made apparent to those skilled in the art by referencing the accompanying drawings. The use of the same reference number throughout the several figures designates a like or similar element.

(24) Figure 1 (labeled prior art) depicts a power control system, which includes a switching power converter.

(25) Figure 2 (labeled prior art) depicts a human audible sensitivity versus audible frequency band graph.

(26) Figure 3A depicts a power control system having a switching power converter and a switch mode controller with a low frequency, broad spectrum strategy module.

(27) Figure 3B depicts a power control system having a boost type switching power converter and a switch mode controller with a low frequency, broad spectrum strategy module.

- (28) Figure 4 depicts a power control system having a switching power converter and a control signal period-power transfer correlation strategy module.
- (29) Figure 5 depicts a low frequency, broad spectrum strategy.
- (30) Figures 6-8 depict low frequency, broad spectrum strategy modules.
- (31) Figures 9-11 depict energy versus frequency graphs for a switch control signal corresponding to respective Figures 6-8.
- (32) Figures 12-14 depict energy versus frequency graphs of switch control signal CS₁.
- (33) Figure 15 depicts nonlinear delta-sigma modulator.
- (34) Figure 16 depicts a proportional integrator.
- (35) Figures 17 and 18 depict respective root mean square value generators.

DETAILED DESCRIPTION

(36) A power control system includes a switch mode controller to control the switching mode of a switching power converter. In at least one embodiment, the switch mode controller also controls power factor correction of the switching power converter. The switch mode controller generates a switch control signal that controls conductivity of a switch of the switching power converter. Controlling conductivity of the switch controls the switch mode of the switching power converter. The switching power converter can be any type of switching power converter, such as a buck mode, boost mode, boost-buck mode, Cúk, mode, Sepic mode, and so on. The switch mode controller controls the switch consistent with the switching power converter type. To control power factor correction, the switch mode controller causes an input current to the switching power converter to vary in approximate proportion to a time varying voltage source signal supplied to the switching power converter.

(37) The switch mode controller includes a period generator to determine a period of the switch control signal and to vary the determined period to generate a broad frequency spectrum of the switch control signal when the determined period corresponds with a frequency in at least a portion of the audible frequency band. Generating a switch control signal with a broad frequency spectrum in the audible

frequency band allows the power control system to utilize switching frequencies in the audible frequency band that have relatively low power at any particular frequency and, in at least one embodiment, tones are also avoided. The broad frequency spectrum can be shaped to minimize power in frequencies within particularly sensitive areas of the audible frequency band. Thus, the power control system can utilize switching frequencies in the audible frequency band without generating sounds.

(38) Figure 3A depicts a power control system 350 having a switching power converter 352 and a switch mode controller 306. The switching power converter 350 can be any type of switching power converter, such as a buck mode, boost mode, boost-buck mode, Cúk, mode, Sepic mode, and so on. The switch mode controller 306 controls the switch mode switch 108 (referred to herein as “switch 108”) consistent with the switching power converter type. Power control system 350 is subsequently described primarily with reference to a boost type switching power converter. The principles of switch mode controller 306 determining a period of the switch control signal CS_1 and varying the determined period to generate a broad frequency spectrum of the switch control signal CS_1 when the determined period corresponds with a frequency in at least a portion of the audible frequency band are applicable to any type of switching power converter. In at least one embodiment, the determined period that is varied is referred to as the nominal period TT_N . The portion or portions of the audible frequency band in which the corresponding period of switch control signal CS_1 is varied is a matter of design choice. In at least one embodiment, the portion is all of the audible frequency band. In another embodiment, the portion is the audible frequency band in which humans are most sensitive, e.g. 50 Hz - 10 kHz.

(39) Figure 3B depicts a power control system 300 having a switching power converter 302 and a switch mode controller 306. Power control system 300 represents one embodiment of power control system 350. Switching power converter 302 is a boost-type converter, and switching power converter 302 represents one embodiment of switching power converter 352. The switching power converter 302 can be any type of switching power converter, such as a buck mode, boost mode, boost-buck mode, Cúk, mode, Sepic mode, and so on. The switch mode controller controls the switch consistent with the switching power converter type.

(40) The switch mode controller 306 includes and utilizes a period generator 308 with a low frequency, broad spectrum strategy module to generate a pulse width modulated switch control signal CS_1 . The switch mode controller 306 generates switch control signal CS_1 using feedback signals representing the primary supply voltage V_X and output voltage V_C . In at least one embodiment, switching power converter 302 is configured in the same manner as switching power converter 102. Rectifier 103 rectifies the input voltage V_{IN} supplied by voltage source 304 to generate time varying, primary supply voltage V_X . In at least one embodiment, voltage source 304 is identical to voltage source 101, and input voltage V_{IN} is identical to the mains voltage V_{mains} .

(41) In at least one embodiment, when the period generator 308 determines a period TT of the switch control signal CS_1 with a corresponding frequency in the audible frequency band, the period generator 308 broadens the spectrum of the switch control signal CS_1 to minimize the audibility of any sounds resulting from the switching of switch mode switch 108. The period generator 308 can utilize any of a number of low frequency, broad spectrum strategies. In at least one embodiment, the period generator 308 can also broaden the spectrum of switch control signal CS_1 for non-audible frequencies in the same manner as broadening the spectrum of the switch control signal CS_1 for audible frequencies to, for example, reduce EMI emissions.

(42) To control power factor correction, the switch mode controller 306 causes the input current i_{IN} to the switching power converter 302 to vary in approximate proportion to a time varying voltage source signal supplied to the switching power converter. U.S. Patent Application No. 11/967,269, entitled "Power Control System Using a Nonlinear Delta-Sigma Modulator with Nonlinear Power Conversion Process Modeling", filed on December 31, 2007, assignee Cirrus Logic, Inc., and inventor John L. Melanson describes exemplary systems and methods for controlling power factor correction and is incorporated herein by reference in its entirety.

(43) Figure 4 depicts a switch mode controller 400, which represents one embodiment of switch mode controller 306. The switch mode controller 400 determines switch control signal CS_1 in accordance with the switch control signal generation strategy implemented by low frequency, broad spectrum strategy module 402. As subsequently described in more detail, the low frequency, broad spectrum

strategy module 402 represents one embodiment of the strategy utilized by period generator 308 to generate a period TT of switch control signal CS₁ to broaden the spectrum of switch control signal CS₁ in at least the audible frequency band in response to the estimated power demand of load 112. In at least one embodiment, the estimated power demand of load 112 is represented by K, and K is provided as an input to low frequency, broad spectrum strategy module 402. “K” is the output of the load power demand estimator 403. In another embodiment, the estimated power delivered to load 112 is estimated by multiplying the average output voltage V_C obtained via voltage control loop 318 and the average output current i_{OUT} of switching power converter 402, and the product can be provided to or determined by low frequency, broad spectrum strategy module 402. The determination of the estimated power delivered to load 112 is a matter of design choice and can be determined in any of a number of ways.

(44) The switch mode controller 400 determines a period TT of switch control signal CS₁ and pulse width T1 of switch control signal CS₁. In at least one embodiment, the square of the pulse width period T1, i.e. T1², is determined in accordance with Equation [1]:

$$T1^2 = \frac{2 \cdot L}{V_{X_RMS}^2} \cdot K \cdot TT \cdot \left(1 - \frac{V_X}{V_C}\right) \quad 1$$

(45) “T1” is the pulse width time of the control signal CS₁. “L” represents an inductor value of inductor 110. V_{X_RMS} represents the primary supply RMS voltage V_{X_RMS}. “K” represents an estimate of the power demand of load 112 as determined by load power demand estimator 403 in the voltage control loop 418. “TT” is the period of control signal CS₁ as generated by control signal period generation strategy module 402. “V_X” is a sampled value of the current value of primary supply voltage V_X. “V_C” is a sampled value of the output voltage V_C from the voltage control loop 418. In the preferred embodiment, the calculation Equation [1] is performed in fixed-point arithmetic with appropriately scaled values and work lengths.

(46) For switch control signal CS₁ frequencies in at least a portion of the audible frequency band, the switch control signal CS₁ period TT is referred to as a nominal period TT_N (Figure 3A). The nominal period TT_N corresponds to a nominal

frequency f_N of the switch control signal CS_1 . In at least one embodiment, the period generator 308 varies the nominal period TT_N to generate a broad frequency spectrum of the switch control signal CS_1 . The actual value of the nominal period TT_N is a matter of design choice and is, for example, dependent upon the values of the components of switching power converter 402 such as the characteristics of inductor 110, switch 108, capacitor 106, and diode 111 along with the instantaneous primary supply voltage V_X , the primary supply RMS voltage V_{X_RMS} , and the power transferred to load 112. As described subsequently in more detail, the low frequency, broad spectrum strategy module 402 varies the nominal period TT_N to broaden the frequency spectrum of the nominal frequency f_N when the nominal frequency f_N resides in at least a portion of the audible frequency band.

(47) The RMS value generator 404 determines primary supply RMS voltage V_{X_RMS} from a sampled primary supply voltage V_X from voltage loop 316. Module 406 receives the primary supply RMS voltage V_{X_RMS} value and determines $2 \cdot L / (V_{X_RMS}^2)$. “ $2 \cdot L / (V_{X_RMS}^2)$ ” represents a scaling factor. Boost factor module 408 determines a boost factor $(1 - V_X / V_C)$. Multiplier 410 multiplies switch control signal CS_1 period TT , the output value of module 406, the output value of boost factor module 408, and estimated power demand K to generate $T1^2$. Nonlinear delta-sigma modulator 412 determines the pulse width $T1$ of switch control signal CS_1 . Pulse width modulator (PWM) 414 receives the pulse width time $T1$ and period TT and generates switch control signal CS_1 so that switch control signal CS_1 has a pulse width of $T1$ and a period of TT .

(48) In at least one embodiment, to ensure that switching power converter 302 operates in DCM, the value L of inductor 110 is set in accordance with Equation [2]:

$$L = V_{\min}^2 / [(P_{\max} \cdot J) \cdot (2 \cdot f_{\max}) \cdot \left[1 - \sqrt{2} \left(\frac{V_{\min}}{V_{\text{cap}}} \right) \right]] \quad [2].$$

(49) “ L ” is the value of the inductor 110. “ V_{\min} ” is the minimum expected primary supply RMS voltage V_{X_RMS} . “ P_{\max} ” is the maximum power demand of load 112. “ J ” is an overdesign factor and any value greater than 1 indicates an overdesign. In at least one embodiment, “ J ” is 1.1. “ f_{\max} ” is a maximum frequency of control signal CS_1 . “ V_C ” is a nominal expected output voltage V_C . The flyback time $T2$ can be determined in accordance with Equation [3]:

$$T2 = \frac{V_X}{V_C - V_X} \quad [3].$$

(50) In at least one embodiment, to avoid saturation of inductor 110, the value L of inductor 110 is chosen so that a peak input current, i_{IN_PEAK} is greater than or equal to the greatest value of $V_X \cdot T1/L$. Generally, the peak input current i_{IN_PEAK} occurs at full output power at the peak of primary supply voltage V_X during low line voltage operation.

(51) Figure 5 depicts an exemplary low frequency, broad spectrum strategy 500 to broaden the spectrum of switch control signal CS_1 for switching frequencies in the audible frequency band. The particular frequency broadening strategy and the range of nominal periods TT_N 's are matters of design choice. The estimated power delivered to load 112 versus switch control signal CS_1 period TT curve 502 depicts an inverse relationship between the estimated power delivered to load 112 and the period TT of switch control signal CS_1 . The curve 502 depicts the nominal period TT_N that corresponds to the nominal frequency f_N of switch control signal CS_1 . The particular relationship between the estimated power delivered to load 112 versus switch control signal CS_1 period TT curve 502 can vary and is a matter of design choice.

(52) When the nominal period TT of switch control signal CS_1 exceeds 50 microseconds, the nominal frequency f_N of switch control signal CS_1 is in the audible frequency band, and the low frequency, broad spectrum strategy module 402 varies the nominal period TT_N to generate a broad frequency spectrum of switch control signal CS_1 . The dashed box 504 depicts a spreading of the period TT around the nominal period TT_N corresponding to the nominal frequency f_N and, thus, indicates a broadening of the frequency spectrum of switch control signal CS_1 . Broadening the frequency spectrum of switch control signal CS_1 spreads the power of tones, thus reducing power at any particular frequency. Broadening the frequency spectrum of switch control signal CS_1 allows switch mode controller 306 to generate switch control signal CS_1 with periods at or above 50 microseconds while minimizing power at audible frequencies.

(53) In at least one embodiment, the inverse relationship between the estimated power delivered to load 112 and the period TT of switch control signal CS_1 improves the efficiency of switch mode controller 306 as described with respect to exemplary

systems and methods in U.S. Patent Application No. _____, entitled “Switching Power Converter With Efficient Switching Control Signal Period Generation”, filed concurrently with the present application, attorney docket no. 1677-CA, assignee Cirrus Logic, Inc., and inventor John L. Melanson, which is incorporated herein by reference in its entirety.

(54) Figure 6 depicts a low frequency, broad spectrum strategy module 600, and low frequency, broad spectrum strategy module 600 represents one embodiment of low frequency, broad spectrum strategy module 402 when the nominal period TT_N is greater than or equal to 50 microseconds. The strategy module 600 generates periods TT_s of switch control signal CS_1 to broaden the frequency spectrum of switch control signal CS_1 and shift the frequencies of switch control signal CS_1 corresponding to the periods generated by strategy module 600 into areas of lower human sensitivity.

(55) The strategy module 600 includes a pseudorandom number (PRN) generator 602 that generates a pseudorandom number PRN. The pseudorandom number PRN is provided to filter 604 to generate a filtered pseudorandom number PRN_F . In at least one embodiment, filter 604 is a high pass filter having a transfer function of, for example, $(1-z^{-1})/(1-.99z^{-1})$. “ z^{-1} ” represents a unit delay in the z-domain. The filtered pseudorandom number PRN_F is provided as an input to randomizer 606. In at least one embodiment, the filtered pseudorandom number PRN_F is scaled and processed along with the nominal period TT_N to generate the randomized period TT_R . The strategy module 600 repeats the generation of the randomized period TT_R to generate multiple randomized periods TT_R 's to broaden the spectrum of the nominal period TT_N . In at least one embodiment, the scaling of filtered pseudorandom number PRN_F determines the amount of frequency spreading of the switching frequencies of switch control signal CS_1 . The randomizer 606 can process the filtered pseudorandom number PRN_F and nominal period TT_N in any of a number of ways. For example, the filtered pseudorandom number PRN_F can be scaled such that the randomizer 606 can multiply the value of TT_N times the pseudorandom number PRN to generate the randomized period TT_R , add the value of TT_N to the pseudorandom number PRN, and so on, to determine a randomized value of nominal period TT_N . The particular scaling and frequency spread of switch control signal CS_1 is a matter of design choice. In at least one embodiment, the strategy module 600 has an operating frequency to

generate multiple pseudorandom number PRN's, multiple filtered pseudorandom number PRN_F's, and multiple randomized periods TT_R's for each nominal period TT_N so that the average of the randomized periods TT_R's for each nominal period TT_N approximately equals the nominal period TT_N. In at least one embodiment, using a high pass filter 604 results in the average of the randomized periods TT_R's having an average value of the nominal period TT_N, and the high pass filter 604 has no DC component. The high pass filter 604 also shifts more sound energy into higher frequencies where the human ear is less sensitive.

(56) In at least one embodiment, filter 604 is a low pass filter. A low pass filter 604 performs an averaging function so that an average of the randomized periods TT_R's over time will equal the nominal period TT_N. In at least one embodiment, the strategy module 600 is designed so that the average of the periods TT generated over a 2-4 second time frame average to the nominal period TT_N.

(57) Figure 9 depicts an energy versus frequency graph 900 of the frequency spectrum of switch control signal CS₁ generated by strategy module 600 with a low pass filter 604. Sensitivity plot 902 indicates human hearing sensitivity levels versus frequency. The dashed tone 904 indicates the frequency and energy of switch control signal CS₁ for a period TT of switch control signal CS₁ generated without broadening the frequency spectrum of switch control signal CS₁. The switch control signal CS₁ frequency graph 906 represents an exemplary broadening of the frequency associated with the period of tone 904. The frequencies of switch control signal CS₁ in graph 906 generated by strategy module 600 are in a frequency range that is less sensitive to humans.

(58) Figure 7 depicts a low frequency, broad spectrum strategy module 700, and low frequency, broad spectrum strategy module 700 represents one embodiment of low frequency, broad spectrum strategy module 402 when the nominal period TT_N is greater than or equal to 50 microseconds. The pseudorandom number PRN generator 602 generates pseudorandom number PRN. Adder 702 adds an approximately equal number of $1/f_L$ and $-1/f_L$ to the pseudorandom number PRN. " f_L " represents minimum and maximum frequency limits of the periods generated by strategy module 700. The randomizer 604 processes pseudorandom number PRN $\pm f_L$ and the nominal period TT_N to generate the randomized period TT_R. In at least one

embodiment, the randomizer 604 adds $PRN \pm f_L$ and the nominal period TT_N , and, in at least one embodiment, randomizer 604 multiplies $PRN \pm f_L$ and the nominal period TT_N . The randomization of nominal period TT_N can be expressed in terms of a percentage of randomization. In other words, the nominal period TT_N could be randomized by a factor of $\pm x\%$, where “x” represents a particular percentage. The particular percentage is a design choice, and larger percentages generally represent broader spectrums of switch control signal CS_1 . In at least one embodiment, the strategy module 700 has an operating frequency to generate multiple pseudorandom number PRN’s and multiple randomized periods TT_R ’s for each nominal period TT_N so that the average of the randomized periods TT_R ’s for each nominal period TT_N approximately equals the nominal period TT_N . Thus, the frequency $1/TT_R$ is shifted by $\pm f_L$ to broaden the spectrum of switch control signal CS_1 .

(59) Figure 10 depicts an energy versus frequency graph 1000 of the frequency spectrum of switch control signal CS_1 generated by strategy module 700. The dashed tone 904 indicates the frequency and energy of switch control signal CS_1 for a period TT of switch control signal CS_1 generated without broadening the frequency spectrum of switch control signal CS_1 . As indicated by graph 1000, the frequencies of switch control signal CS_1 corresponding to the periods of switch control signal CS_1 generated by strategy module 700 are spread across frequencies as, for example, indicated by the frequency spectrum 1002 ranging from $1/TT_N - f_L$ to $1/TT_N + f_L$ and centered around the nominal frequency $f_N = 1/TT_N$. The broadening of the frequency spectrum of switch control signal CS_1 avoids repeating tones and spreads energy across multiple frequencies so that any sounds generated by switch control signal CS_1 are less perceptible to humans.

(60) Figure 8 depicts a low frequency, broad spectrum strategy module 800, and low frequency, broad spectrum strategy module 800 represents one embodiment of low frequency, broad spectrum strategy module 402 when the nominal period TT_N is greater than or equal to 50 microseconds. Strategy module 800 modulates the output TT_{700} of strategy module 700 with a delta-sigma modulator 802 to noise shape the broadened frequency spectrum of switch control signal CS_1 corresponding to the periods TT_{700} generated by strategy module 700. The delta-sigma modulator 802 further broadens the spectrum of the nominal period TT_N and also avoids repeating

tones. In at least one embodiment, the strategy module 800 has an operating frequency sufficiently high so that the average of the randomized periods TT_R 's for each nominal period TT_N approximately equals the nominal period TT_N . Exemplary conventional delta-sigma modulator design and operation is described in the book *Understanding Delta-Sigma Data Converters* by Schreier and Temes, IEEE Press, 2005, ISBN 0-471-46585-2.

(61) Figure 11 depicts an energy versus frequency graph 1100 of the frequency spectrum of switch control signal CS_1 generated by strategy module 800. The dashed tone 904 indicates the frequency and energy of switch control signal CS_1 for a period TT of switch control signal CS_1 generated without broadening the frequency spectrum of switch control signal CS_1 . As indicated by graph 1102, the frequencies of switch control signal CS_1 corresponding to the periods of switch control signal CS_1 generated by strategy module 800 are shaped to spread across frequencies in the audible frequency band. The broadening of the frequency spectrum of switch control signal CS_1 avoids repeating tones and spreads energy across multiple frequencies so that any sounds generated by switch control signal CS_1 are less perceptible to humans.

(62) Figure 12 depicts a frequency versus switch control signal CS_1 energy graph 1200 for determined periods TT 's of switch control signal CS_1 corresponding to multiple frequencies within the audible frequency band. The graph 1200 represents no randomization of the determined periods TT 's.

(63) Figure 13 depicts a frequency versus switch control signal CS_1 energy graph 1300 for randomized periods TT_R 's of multiple determined periods TT_N 's of switch control signal CS_1 . The graph 1300 demonstrates a significant broadening of the spectrum of switch control signal CS_1 and lower peak energy levels relative to the peak energy levels of graph 1200. The lower peak energy levels result in lower energy sound caused by switch control signal CS_1 .

(64) Figure 14 also depicts a frequency versus switch control signal CS_1 energy graph 1400 for randomized periods TT_R 's of multiple determined periods TT_N 's of switch control signal CS_1 . The spectrum of switch control signal CS_1 is broadened in graph 1400 using strategy module 600 and a high pass filter 604. In this embodiment, the high pass filter 604 has a transfer function of $(1-z^{-1})/(1-.99 z^{-1})$. The graph 1400

demonstrates an approximately 12 dB decrease of peak energy levels relative to the peak energy levels of graph 1300. The lower peak energy levels result in lower energy sound caused by switch control signal CS₁.

(65) Figure 15 depicts nonlinear delta-sigma modulator 1500, which represents one embodiment of nonlinear delta-sigma modulator 412. The nonlinear delta-sigma modulator 1500 models a nonlinear power transfer process of switching power converter 302. The nonlinear power transfer process of switching power converter 302 can be modeled as a square function, x^2 . Nonlinear delta-sigma modulator 1500 includes a nonlinear system feedback model 1502 represented by x^2 . The output of feedback model 1502 is the square of delay-by-one quantizer output signal T1, i.e. $[T1(n-1)]^2$. Delay z^{-1} 1506 represents a delay-by-one of quantizer output signal T1. Negative $[T1(n-1)]^2$ is added to $T1^2$ by adder 1512. The nonlinear delta-sigma modulator 1500 includes a compensation module 1504 that is separate from quantizer 1508. The nonlinearity compensation module 1504 processes output signal $u(n)$ of the loop filter 1510 with a square root function $x^{1/2}$ to compensate for nonlinearities introduced by the nonlinear feedback model 1502. The output $c(n)$ of compensation module 1504 is quantized by quantizer 1508 to generate switch control signal CS₁ pulse width T1.

(66) Figure 16 depicts a proportional integrator (PI) compensator 1600, which represents one embodiment of load power demand estimator 403. The PI compensator 1600 generates the load power demand signal K. The load power demand signal K varies as the difference between a reference voltage V_{REF} and the output voltage V_C , as represented by error signal e_v from error generator 1601, varies. The reference signal V_{REF} is set to a desired value of output voltage V_C . The PI compensator 1600 includes an integral signal path 1602 and a proportional signal path 1604. The integral signal path includes an integrator 1606 to integrate the error signal e_v , and a gain module 1608 to multiply the integral of error signal e_v by a gain factor g_2 and generate the integrated output signal I_{PW} . The proportional path 1604 includes a gain module 1610 to multiply the error signal e_v by a gain factor g_1 and generate the proportional output signal P_{PW} . Adder 1612 adds the integrated output signal I_{PW} and the proportional output signal P_{PW} to generate the load power demand signal K.

(67) The values of gain factors g_1 and g_2 are a matter of design choice. The gain factors g_1 and g_2 affect the responsiveness of switch mode controller 306. Exemplary values of gain factors g_1 and g_2 are set forth in the emulation code of Figures 8-31 of U.S. Patent Application Serial No. 11/967,269, entitled "Power Control System Using a Nonlinear Delta-Sigma Modulator with Nonlinear Power Conversion Process Modeling", filed December 31, 2007, assignee Cirrus Logic, Inc., and inventor John L. Melanson. U.S. Patent Application Serial No. 11/967,269 describes exemplary systems and methods and is incorporated herein by reference in its entirety. Faster response times of the switch mode controller 306 allow the switch control signal CS_1 to more rapidly adjust to minimize the error signal e_v . If the response is too slow, then the output voltage V_C may fail to track changes in power demand of load 112 and, thus, fail to maintain an approximately constant value. If the response is too fast, then the output voltage V_C may react to minor, brief fluctuations in the power demand of load 112. Such fast reactions could cause oscillations in switch mode controller 306, damage or reduce the longevity of components, or both. The particular rate of response by proportional integrator 1600 is a design choice.

(68) Figures 17 and 18 depict respective exemplary embodiments of RMS value generator 404. The RMS value of primary supply voltage V_X is the square root of the average of the squares of primary supply voltage V_X . RMS value generator 1700 receives a set $\{V_X\}$ samples of primary supply voltage V_X during a cycle of primary supply voltage V_X and squaring module 1702 squares each sample of primary supply voltage to determine a set $\{V_X^2\}$. Low pass filter 1704 determines a mean $V_{X^2_MEAN}$ of the set $\{V_X^2\}$. Square root module 1706 determines the square root of $V_{X^2_MEAN}$ to determine the primary supply RMS voltage V_{X_RMS} .

(69) The RMS value generator 1800 receives the primary supply voltage V_X and peak detector 1802 determines a peak value V_{X_PEAK} of primary supply voltage V_X . Since primary supply voltage V_X is a sine wave in at least one embodiment, multiplying V_{X_PEAK} by $\sqrt{2}/2$ with multiplier 1804 generates primary supply RMS voltage V_{X_RMS} . In at least one embodiment, as the exact value of V_{X_PEAK} is not critical, the determination of V_{X_PEAK} by RMS value generator 1800 is generally adequate.

(70) Thus, generating a switch control signal with a broad frequency spectrum in the audible frequency band allows the power control system 300 to utilize switching frequencies in the audible frequency band that have relatively low power at any particular frequency and, in at least one embodiment, tones are also avoided.

(71) Although the present invention has been described in detail, it should be understood that various changes, substitutions and alterations can be made hereto without departing from the spirit and scope of the invention as defined by the appended claims.

WHAT IS CLAIMED IS:

- 1 1. A system comprising:
2 a switch mode controller to generate a switch control signal to control
3 conductivity of a switching mode switch included in a switching power
4 converter, wherein the switch mode controller comprises:
5 a period generator to determine a nominal period of the switch control
6 signal and to vary the nominal period to generate a broad
7 frequency spectrum of the switch control signal when the
8 nominal period corresponds with a frequency in at least a
9 portion of an audible frequency band.
- 1 2. The system of claim 1 wherein the period generator is further
2 configured to generate a broad frequency spectrum of the switch control signal having
3 randomly selected periods.
- 1 3. The system of claim 3 wherein an average of the randomly selected
2 periods approximately equals the nominal period.
- 1 4. The system of claim 1 wherein the period generator further comprises
2 a pseudo random number generator to generate pseudorandom numbers, and the
3 period generator is further configured to generate a broad frequency spectrum of the
4 switch control signal having randomly selected periods based on the pseudorandom
5 numbers.
- 1 5. The system of claim 1 wherein the period generator is further
2 configured to generate the broad frequency spectrum of the switch control signal
3 using periods determined using low pass filtered, pseudo random numbers.
- 1 6. The system of claim 1 wherein the period generator is further
2 configured to generate the broad frequency spectrum of the switch control signal
3 using periods determined using high pass filtered, pseudo random numbers.

1 7. The system of claim 1 wherein the period generator is further
2 configured to generate the broad frequency spectrum of the switch control signal
3 using delta-sigma modulated, randomized values of the nominal period.

1 8. The system of claim 1 wherein the audible frequency band is
2 approximately 20 Hz to 20 kHz.

1 9. The system of claim 1 wherein the switch mode controller is further
2 configured to control conductivity of the switch mode switch to cause an input current
3 to the switching power converter to vary in approximate proportion to a time varying
4 voltage source signal supplied to the switching power converter, wherein the switch
5 mode controller further comprises:

6 a pulse width generator to determine a pulse width of the switch control signal
7 in response to (i) the nominal period of the switch control signal, (ii) a
8 voltage level of the voltage source signal, and (iii) a voltage level of
9 the output voltage signal of the switching power converter.

1 10. A method comprising:
2 generating a switch control signal to control conductivity of a switch mode
3 switch included in a switching power converter;
4 determining a nominal period of the switch control signal;
5 varying the nominal period to generate a broad frequency spectrum of the
6 switch control signal when the nominal period corresponds with a
7 frequency in at least a portion of an audible frequency band;
8 determining a pulse width of the switch control signal; and
9 providing the switch control signal to the switch of the switching power
10 converter.

1 11. The method of claim 10 further comprising:
2 controlling conductivity of the switch to cause an input current to the
3 switching power converter to vary in approximate proportion to a time

4 varying voltage source signal supplied to the switching power
5 converter; and
6 determining a pulse width of the switch control signal further comprises
7 determining a pulse width of the switch control signal in response to (i)
8 the nominal period of the switch control signal, (ii) a voltage level of
9 the voltage source signal, and (iii) a voltage level of the output voltage
10 signal of the switching power converter.

1 12. The method of claim 10 wherein varying the nominal period to
2 generate a broad frequency spectrum of the switch control signal further comprises
3 generating a broad frequency spectrum of the switch control signal having randomly
4 selected periods.

1 13. The method of claim 12 wherein an average of the randomly selected
2 periods approximately equals the nominal period.

1 14. The method of claim 10 wherein varying the nominal period to
2 generate a broad frequency spectrum of the switch control signal further comprises
3 generating pseudorandom numbers and generating a broad frequency spectrum of the
4 switch control signal having randomly selected periods based on the pseudorandom
5 numbers.

1 15. The method of claim 10 wherein varying the nominal period to
2 generate a broad frequency spectrum of the switch control signal further comprises
3 generating the broad frequency spectrum of the switch control signal using periods
4 determined using low pass filtered, pseudo random numbers.

1 16. The method of claim 10 wherein varying the nominal period to
2 generate a broad frequency spectrum of the switch control signal further comprises
3 generating the broad frequency spectrum of the switch control signal using periods
4 determined using high pass filtered, pseudo random numbers.

1 17. The method of claim 10 wherein varying the nominal period to
2 generate a broad frequency spectrum of the switch control signal further comprises
3 generating the broad frequency spectrum of the switch control signal using delta-
4 sigma modulated, randomized values of the nominal period.

1 18. The method of claim 10 wherein the audible frequency band is
2 approximately 20 Hz to 20 kHz.

1 19. The method of claim 10 further comprising:
2 controlling conductivity of the switch to cause an input current to the
3 switching power converter to vary in approximate proportion to a time
4 varying voltage source signal supplied to the switching power
5 converter; and
6 determining a pulse width of the switch control signal further comprises
7 determining a pulse width of the switch control signal in response to (i)
8 the nominal period of the switch control signal, (ii) a voltage level of
9 the voltage source signal, and (iii) a voltage level of the output voltage
10 signal of the switching power converter.

1 20. A power control system comprising:
2 a switching power converter having a switch; and
3 a switch mode controller to generate a switch control signal to control
4 conductivity of a switching mode switch included in a switching power
5 converter, wherein the switch mode controller comprises:
6 a period generator to determine a nominal period of the switch control
7 signal and to vary the nominal period to generate a broad
8 frequency spectrum of the switch control signal when the
9 nominal period corresponds with a frequency in at least a
10 portion of an audible frequency band.

1 21. The power control system of claim 20 wherein the period generator is
2 further configured to generate a broad frequency spectrum of the switch control signal
3 having randomly selected periods.

1 22. The power control system of claim 20 wherein the switching power
2 converter further includes an input node, an inductor coupled to the input node and
3 the switch, a diode coupled to the switch and the inductor, and an output capacitor
4 coupled to the diode.

1 23. The power control system of claim 20 wherein the switch mode
2 controller is further configured to control conductivity of the switch mode switch to
3 cause an input current to the switching power converter to vary in approximate
4 proportion to a time varying voltage source signal supplied to the switching power
5 converter, wherein the switch mode controller further comprises:

6 a pulse width generator to determine a pulse width of the switch control signal
7 in response to (i) the nominal period of the switch control signal, (ii) a
8 voltage level of the voltage source signal, and (iii) a voltage level of
9 the output voltage signal of the switching power converter.

1 24. An apparatus comprising:
2 means for generating a switch control signal to control conductivity of a
3 switch mode switch included in a switching power converter;
4 means for determining a nominal period of the switch control signal;
5 means for varying the nominal period to generate a broad frequency spectrum
6 of the switch control signal when the nominal period corresponds with
7 a frequency in at least a portion of an audible frequency band;
8 means for determining a pulse width of the switch control signal; and
9 means for providing the switch control signal to the switch of the switching
10 power converter.

1 25. The apparatus of claim 24 further comprising:
2 means for controlling conductivity of the switch to cause an input current to
3 the switching power converter to vary in approximate proportion to a
4 time varying voltage source signal supplied to the switching power
5 converter; and
6 means for determining a pulse width of the switch control signal further
7 comprises determining a pulse width of the switch control signal in
8 response to (i) the nominal period of the switch control signal, (ii) a
9 voltage level of the voltage source signal, and (iii) a voltage level of
10 the output voltage signal of the switching power converter.

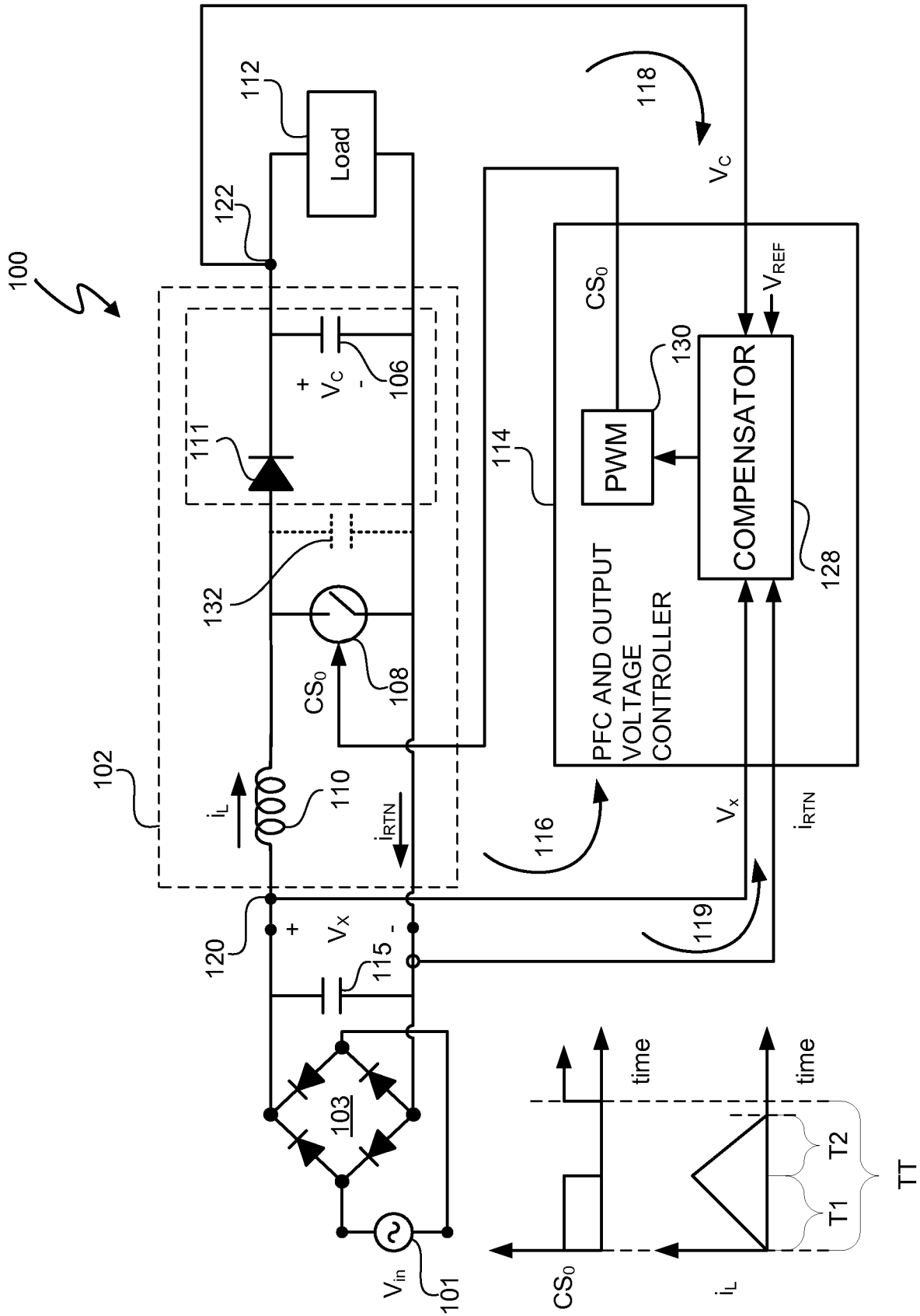

Figure 1 (prior art)

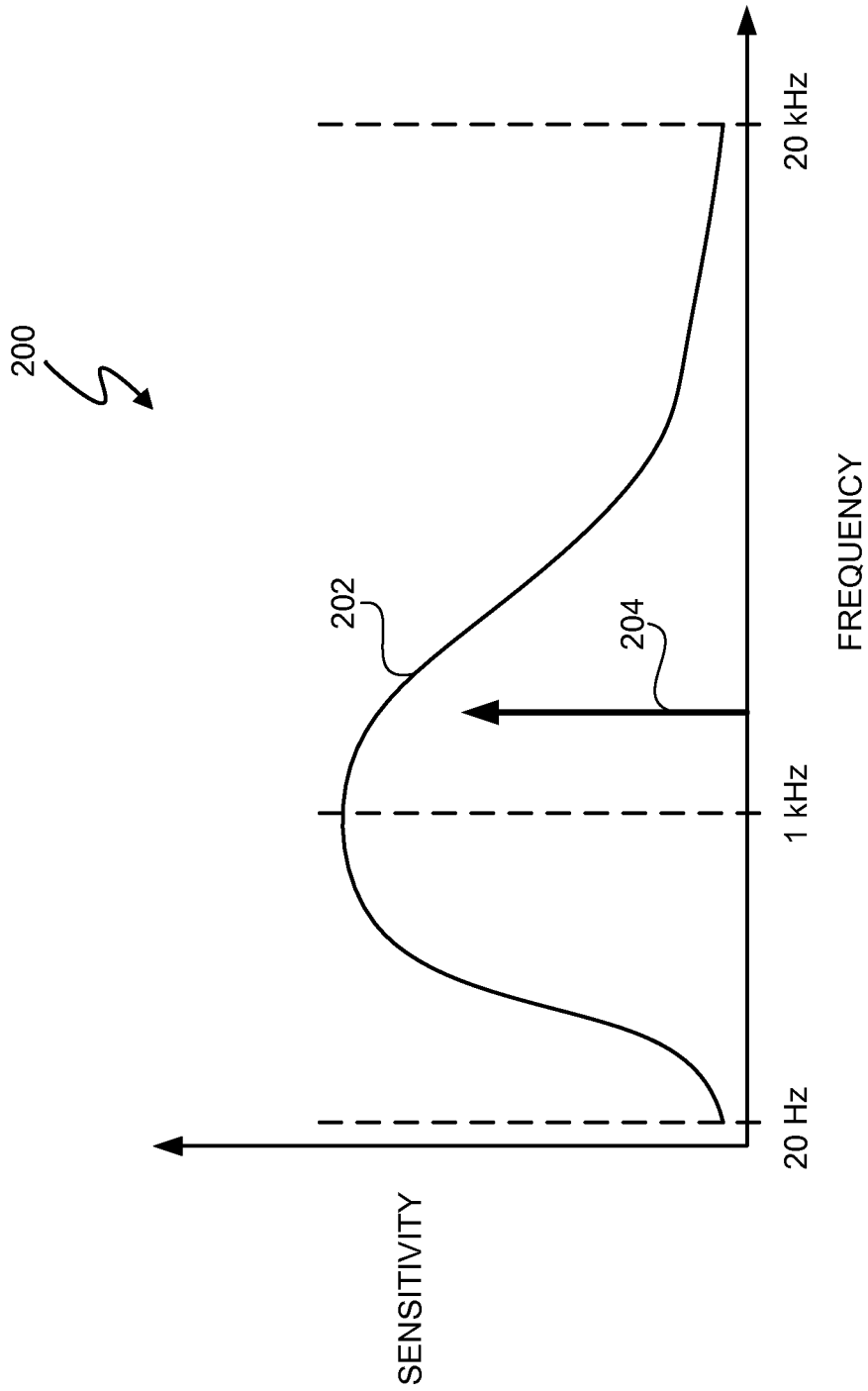

Figure 2 (prior art)

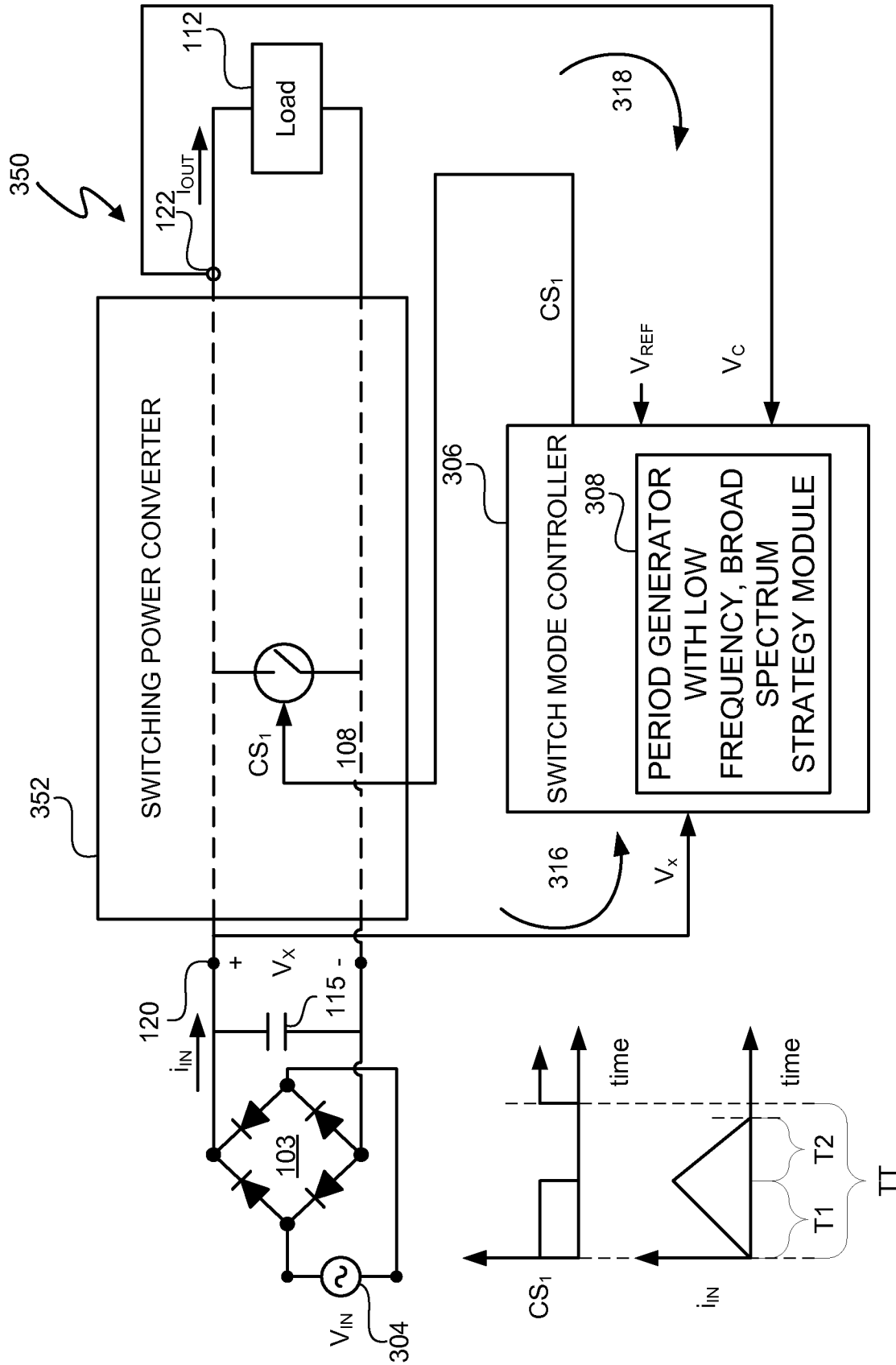
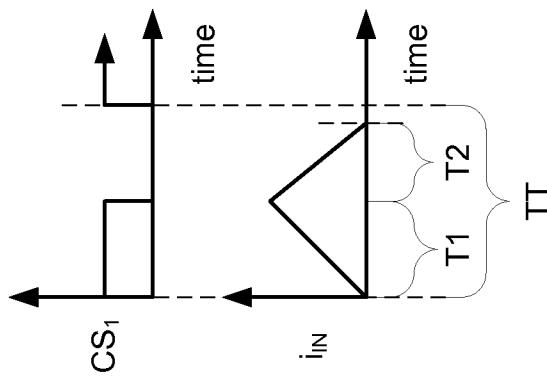

Figure 3A

(T_{TN} FOR AT LEAST A PORTION OF THE AUDIBLE FREQUENCY BAND)



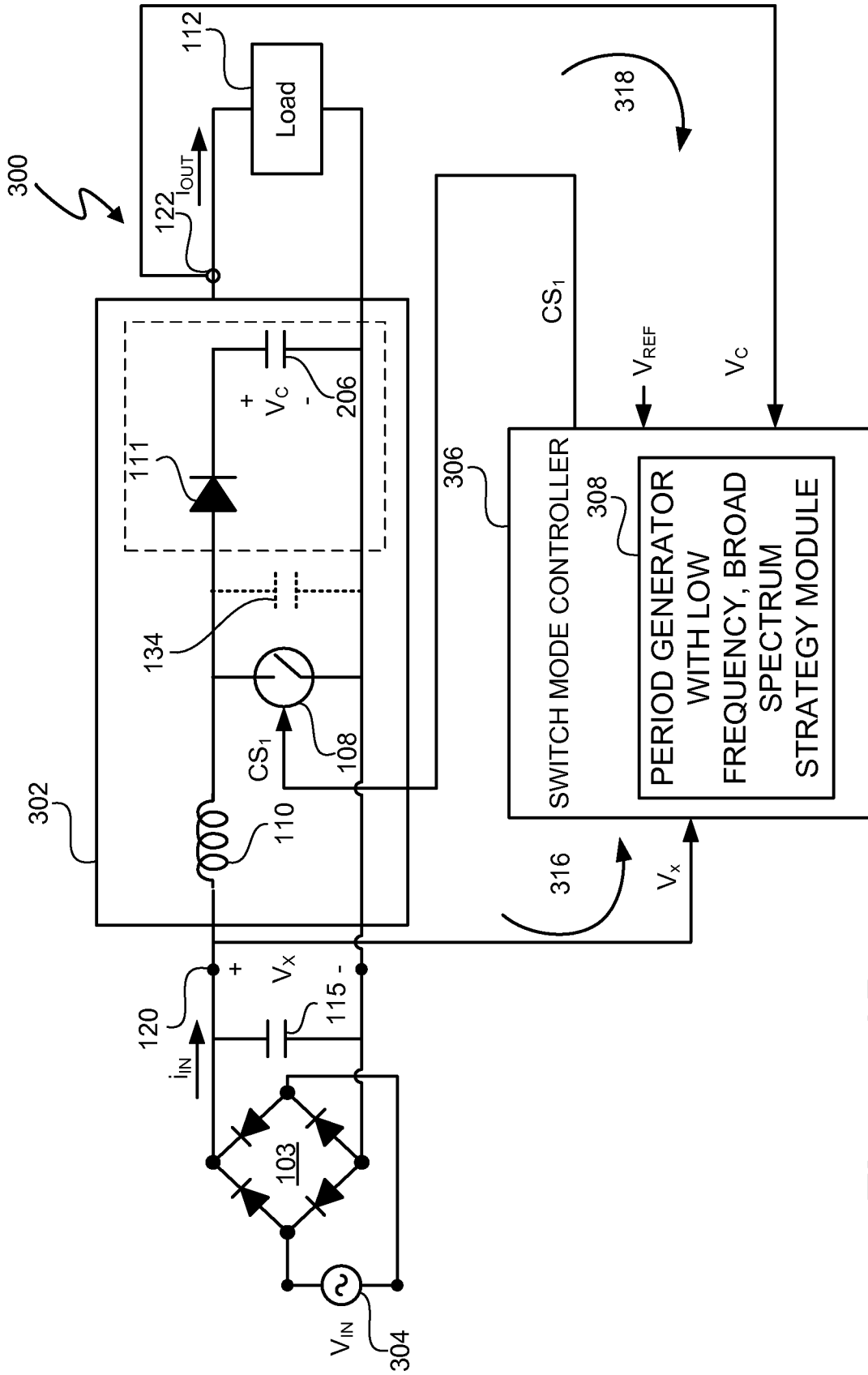

Figure 3B

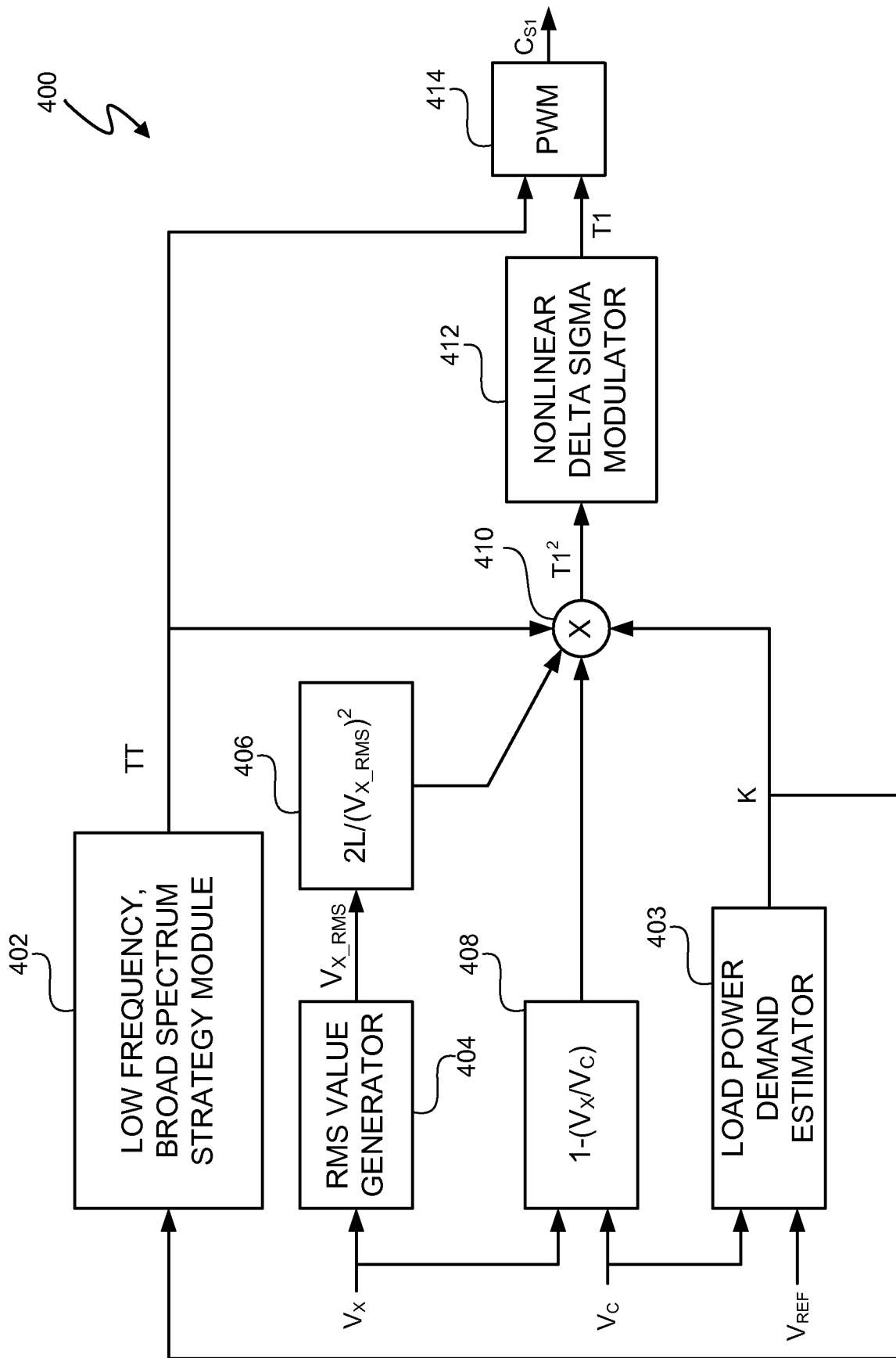

Figure 4

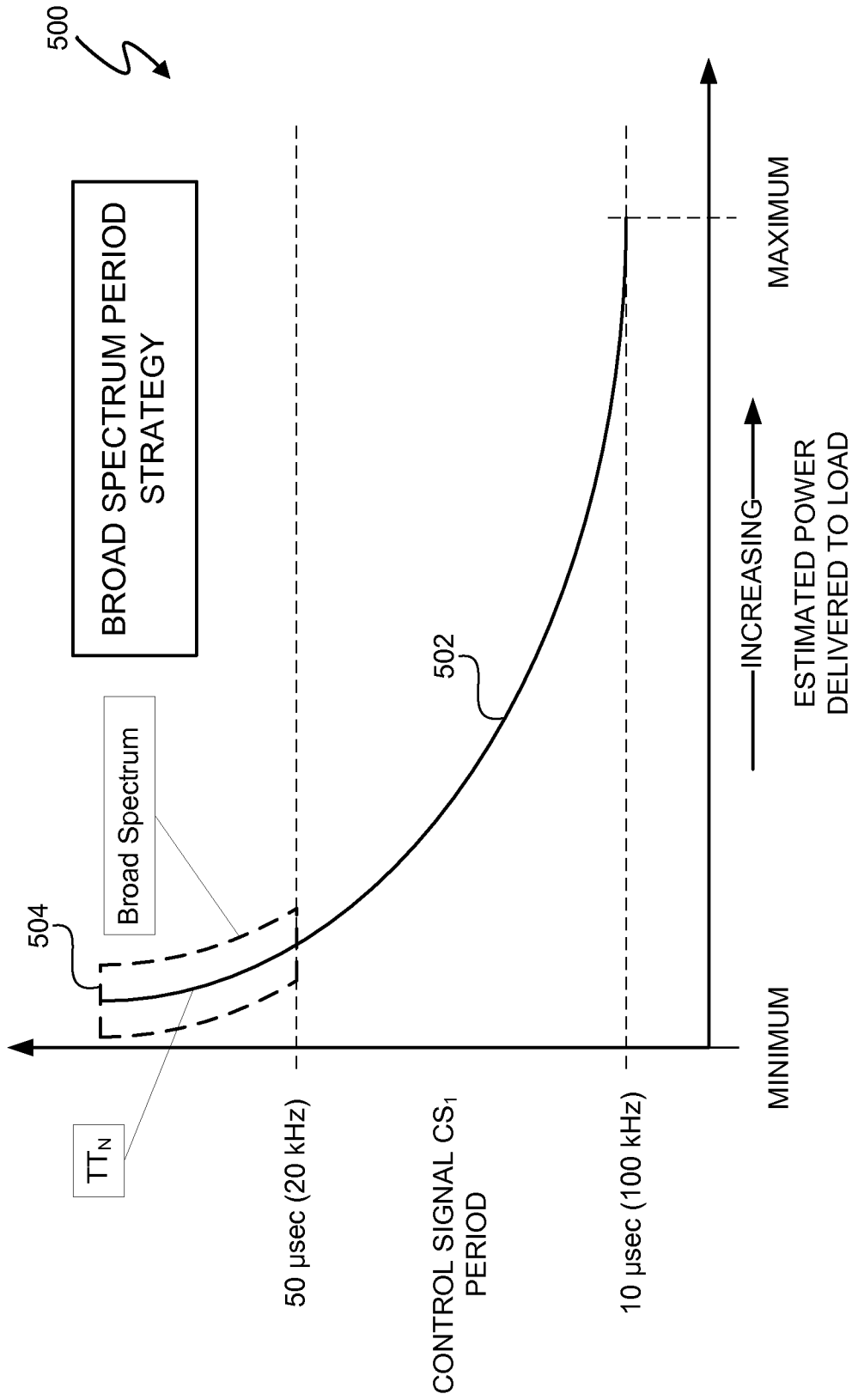

Figure 5

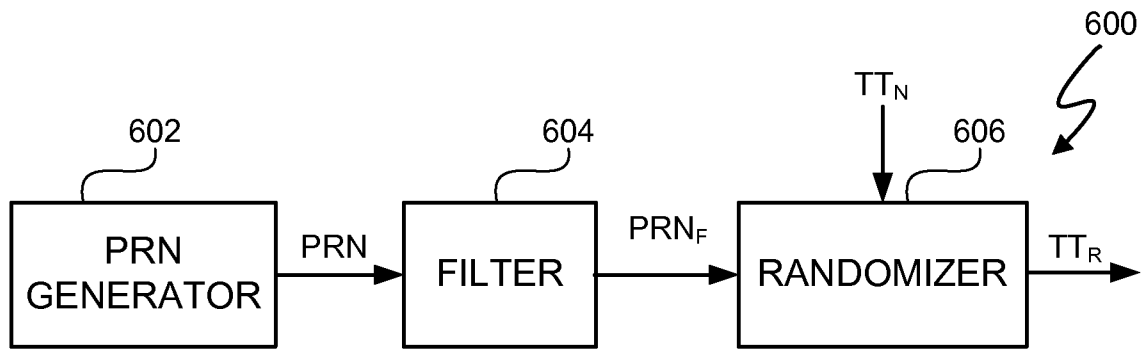

Figure 6

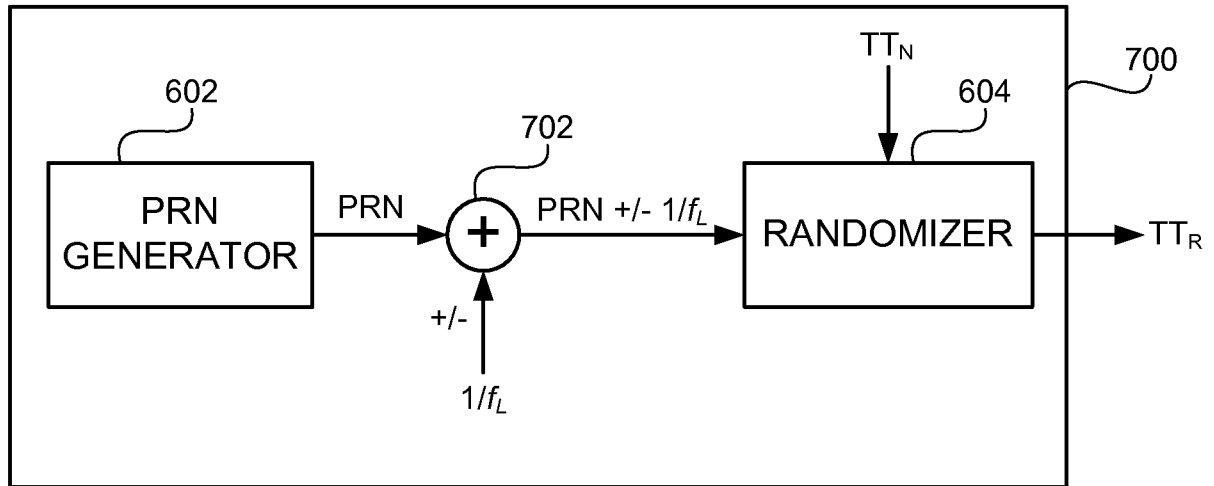

Figure 7

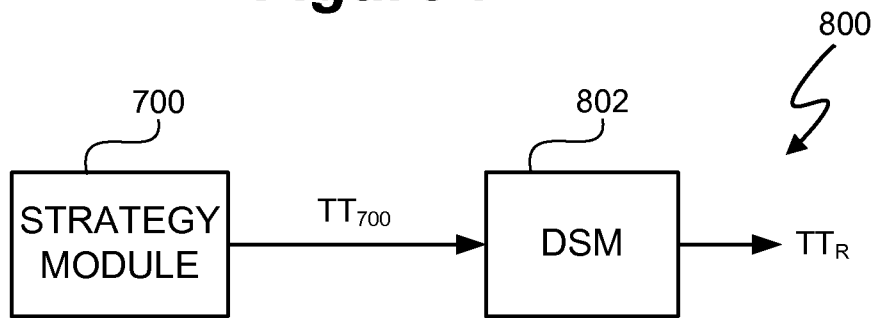

Figure 8

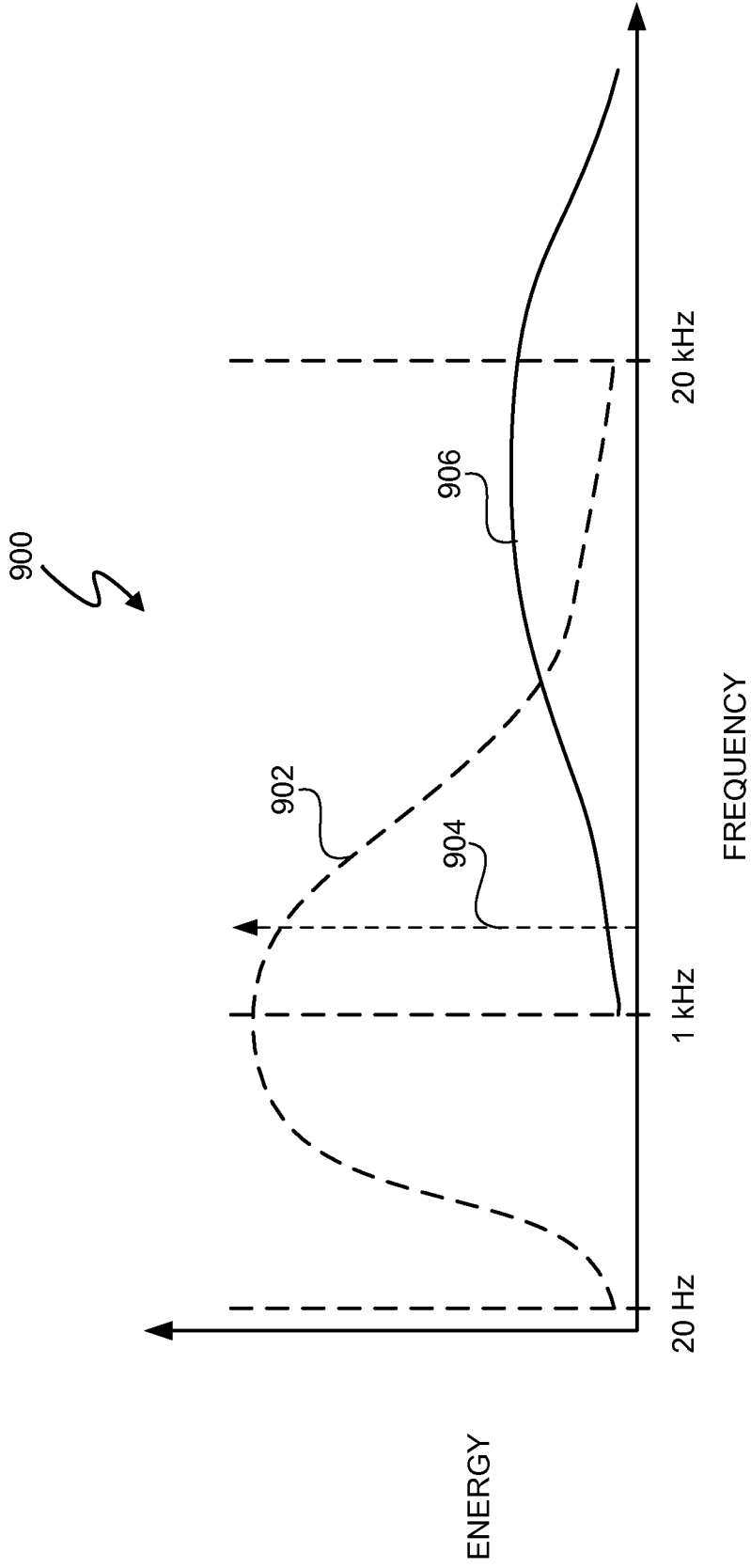

Figure 9

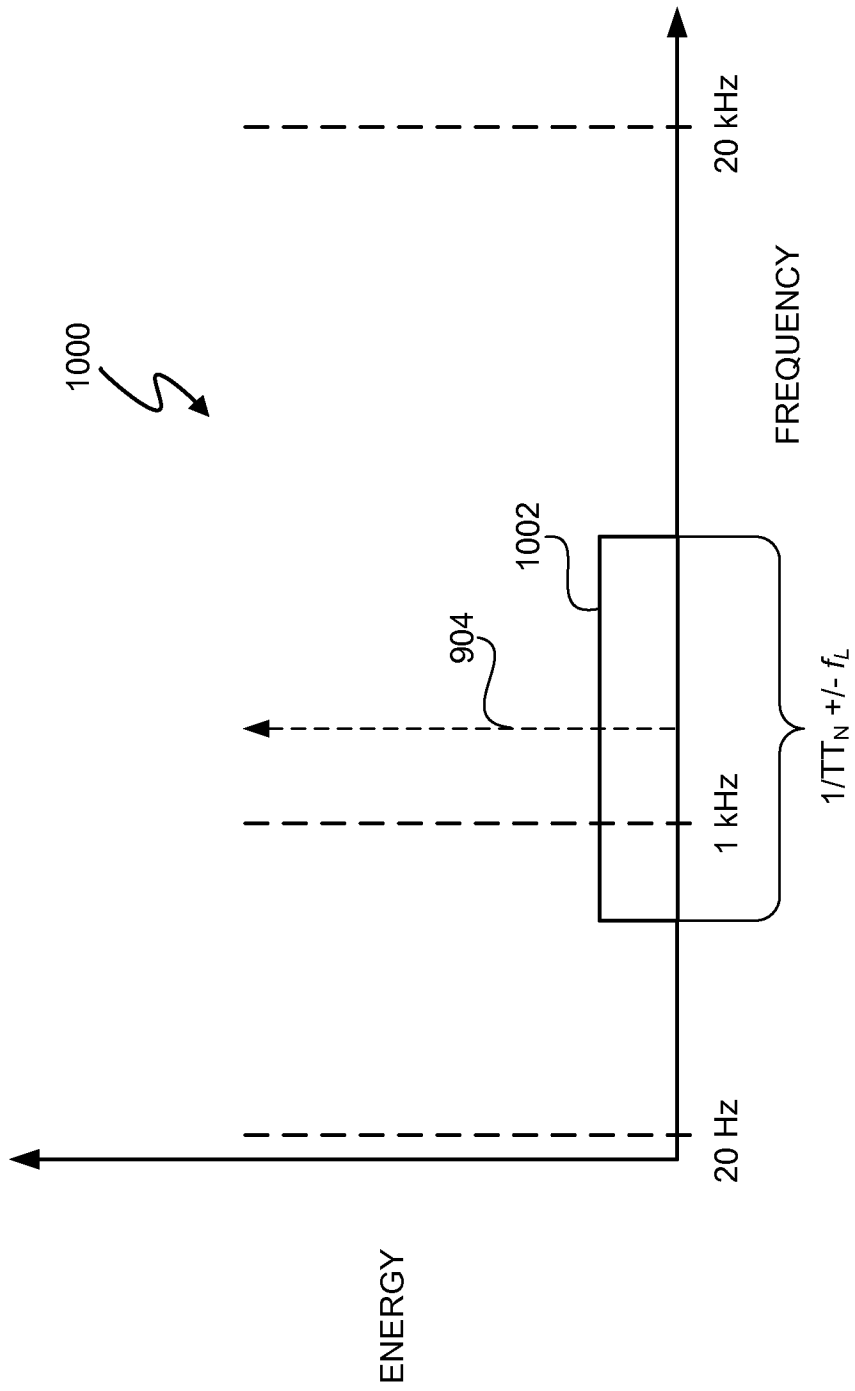

Figure 10

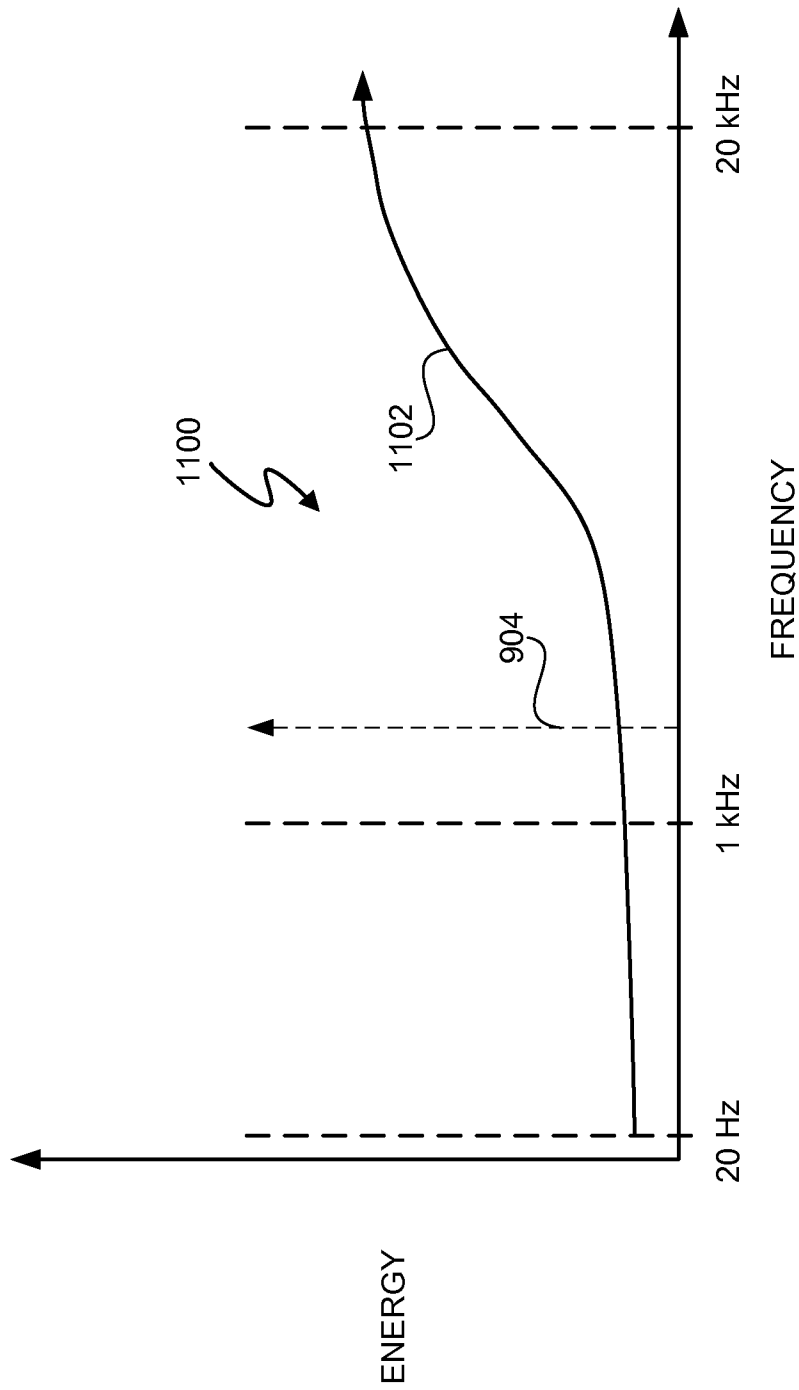

Figure 11

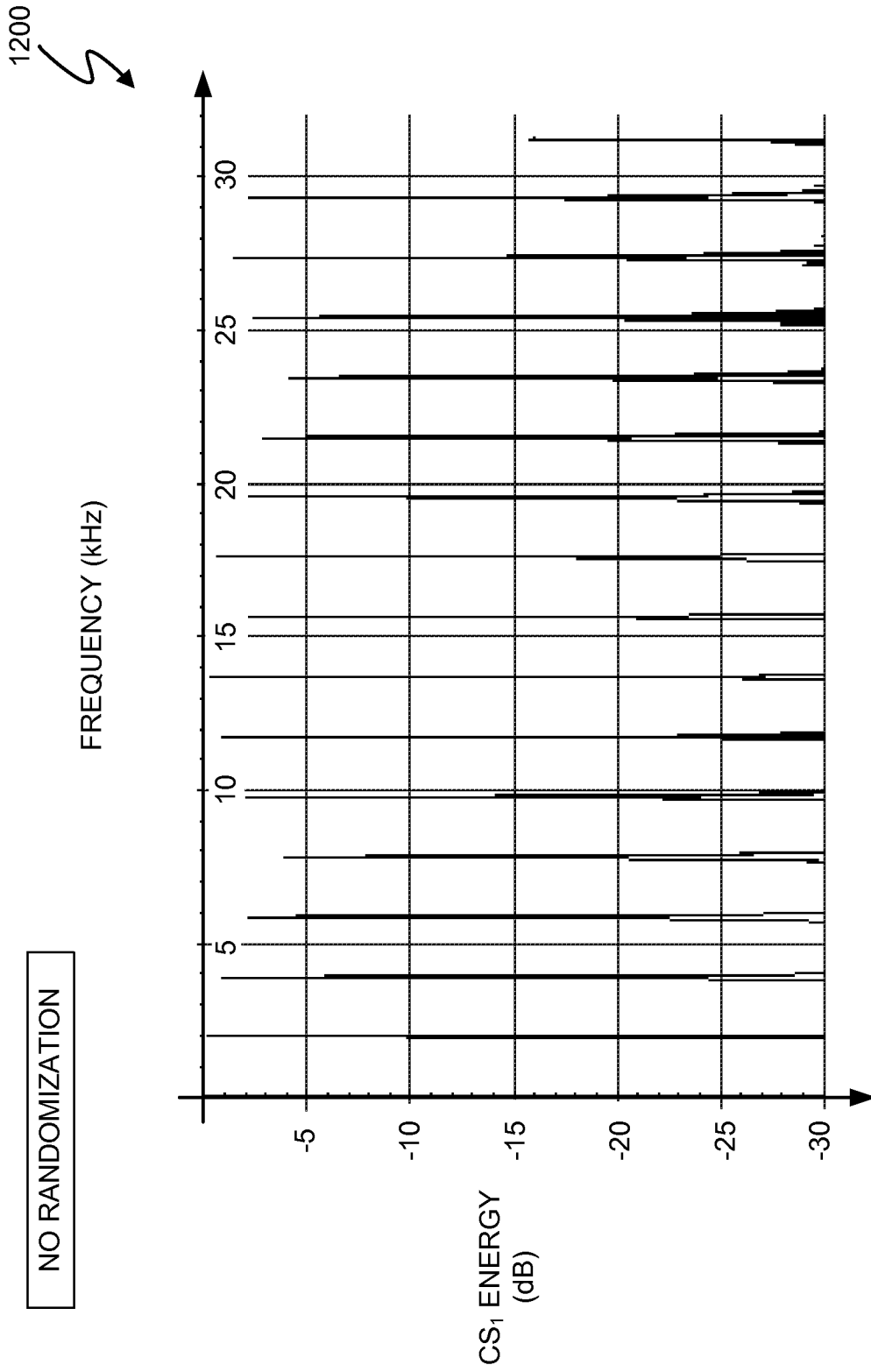

Figure 12

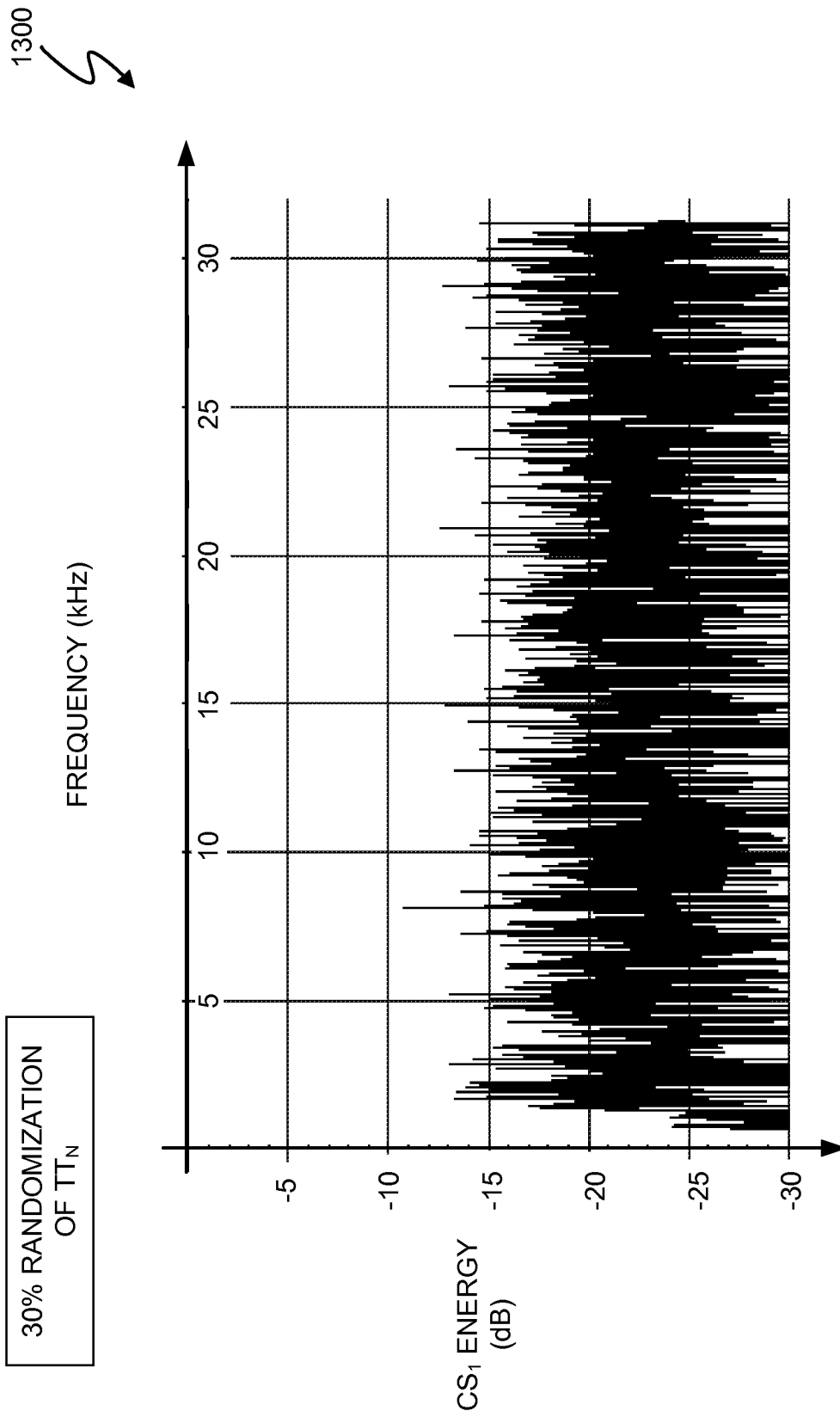

Figure 13

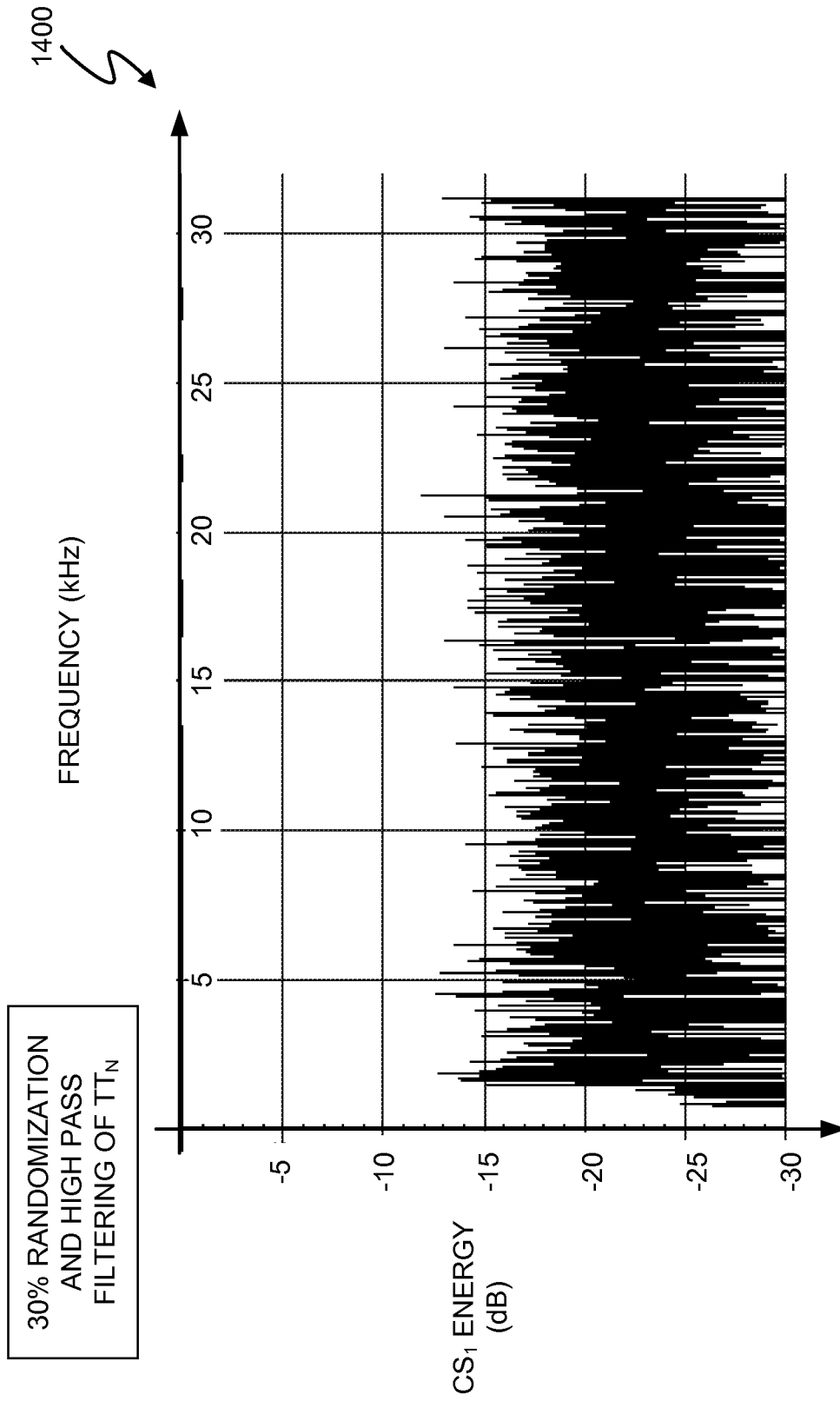

Figure 14

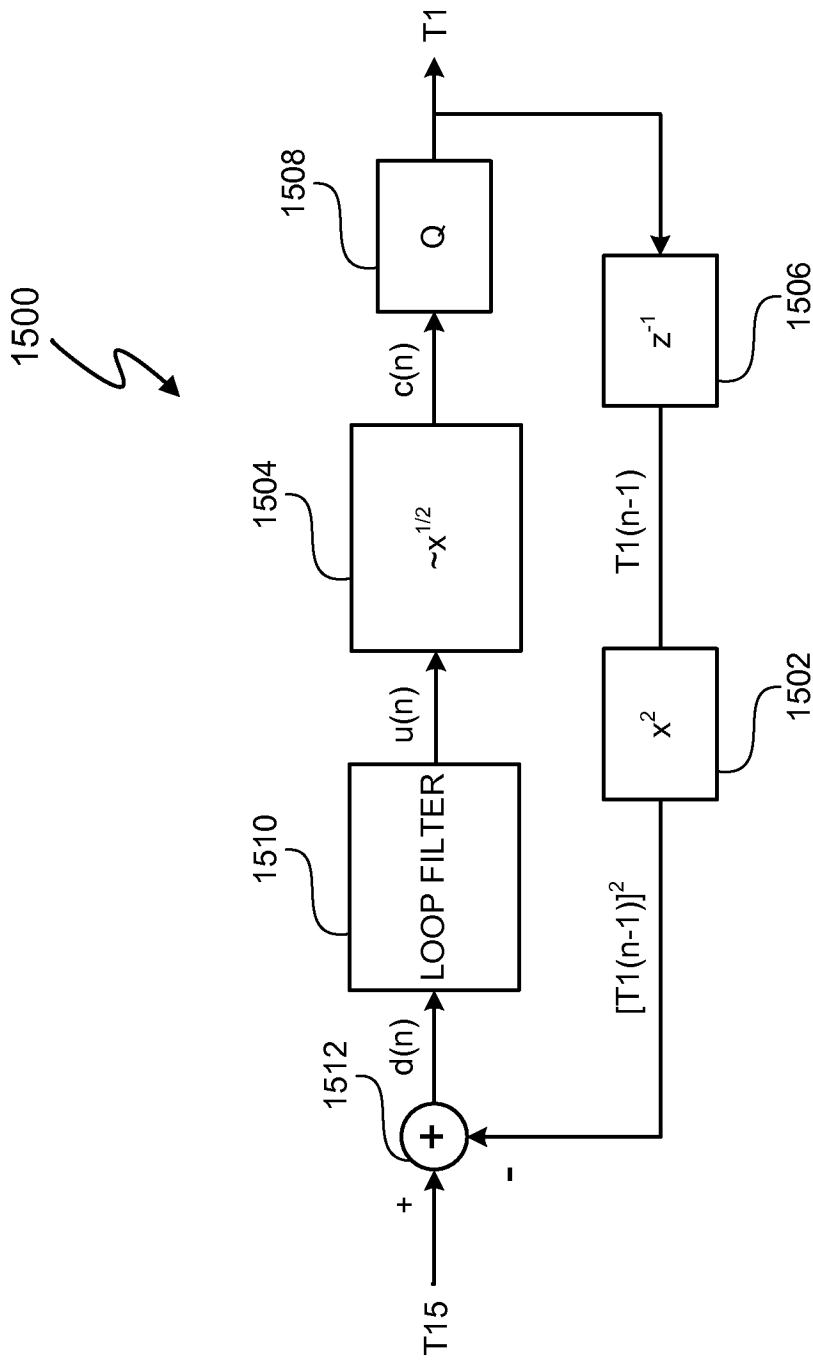

Figure 15

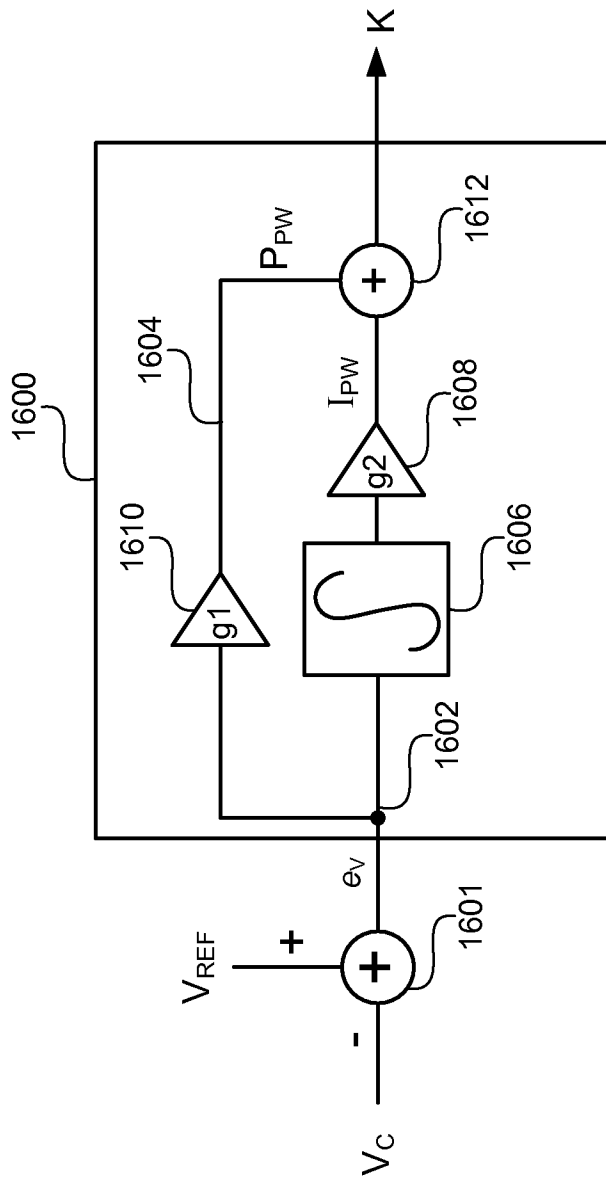

Figure 16

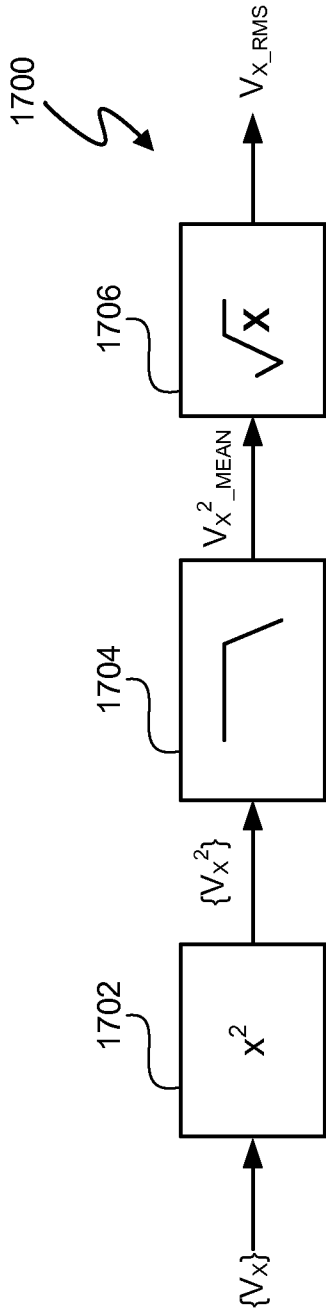

Figure 17

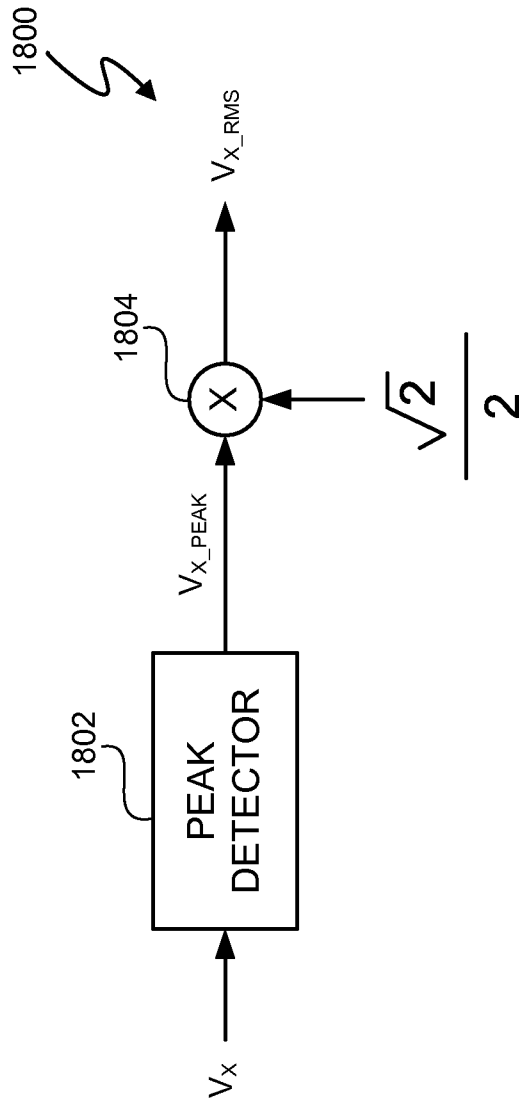

Figure 18

INTERNATIONAL SEARCH REPORT

International application No
PCT/US2008/062423

A. CLASSIFICATION OF SUBJECT MATTER INV. H02M3/156		
According to International Patent Classification (IPC) or to both national classification and IPC		
B. FIELDS SEARCHED Minimum documentation searched (classification system followed by classification symbols) H02M H03K H03F H02P G05B		
Documentation searched other than minimum documentation to the extent that such documents are included in the fields searched		
Electronic data base consulted during the international search (name of data base and, where practical, search terms used) EPO-Internal, INSPEC, WPI Data		
C. DOCUMENTS CONSIDERED TO BE RELEVANT		
Category*	Citation of document, with indication, where appropriate, of the relevant passages	Relevant to claim No.
X	US 2006/221646 A1 (YE JUN [CN] ET AL) 5 October 2006 (2006-10-05) paragraphs [0007] - [0031]; figure 1 ----- -/--	1-6,8, 10-16, 18,19,24
<input checked="" type="checkbox"/> Further documents are listed in the continuation of Box C. <input checked="" type="checkbox"/> See patent family annex.		
* Special categories of cited documents :		
<ul style="list-style-type: none"> *A* document defining the general state of the art which is not considered to be of particular relevance *E* earlier document but published on or after the international filing date *L* document which may throw doubts on priority claim(s) or which is cited to establish the publication date of another citation or other special reason (as specified) *O* document referring to an oral disclosure, use, exhibition or other means *P* document published prior to the international filing date but later than the priority date claimed *T* later document published after the international filing date or priority date and not in conflict with the application but cited to understand the principle or theory underlying the invention *X* document of particular relevance; the claimed invention cannot be considered novel or cannot be considered to involve an inventive step when the document is taken alone *Y* document of particular relevance; the claimed invention cannot be considered to involve an inventive step when the document is combined with one or more other such documents, such combination being obvious to a person skilled in the art. *&* document member of the same patent family 		
Date of the actual completion of the international search 31 July 2008		Date of mailing of the international search report 11/08/2008
Name and mailing address of the ISA/ European Patent Office, P.B. 5818 Patentlaan 2 NL - 2280 HV Rijswijk Tel. (+31-70) 340-2040, Tx. 31 651 epo nl; Fax: (+31-70) 340-3016		Authorized officer Braccini, Roberto

INTERNATIONAL SEARCH REPORT

International application No

PCT/US2008/062423

C(Continuation). DOCUMENTS CONSIDERED TO BE RELEVANT		
Category*	Citation of document, with indication, where appropriate, of the relevant passages	Relevant to claim No.
X	BOURGEOIS J M ED - INSTITUTE OF ELECTRICAL AND ELECTRONICS ENGINEERS: "PWM technique for acoustic noise reduction in power applications" PROCEEDINGS OF THE ANNUAL APPLIED POWER ELECTRONICS CONFERENCE AND EXPOSITION (APEC). SAN DIEGO, MAR. 7 - 11, 1993; [PROCEEDINGS OF THE ANNUAL APPLIED POWER ELECTRONICS CONFERENCE AND EXPOSITION (APEC)], NEW YORK, IEEE, US, vol. CONF. 8, 7 March 1993 (1993-03-07), pages 141-145, XP010111231 ISBN: 978-0-7803-0983-8 the whole document	1-4, 8, 10, 12-14, 18-21, 24
X	HIROTA A ET AL: "Analysis of single switch delta-sigma modulated pulse space modulation PFC converter effectively using switching power device" 33RD. ANNUAL IEEE POWER ELECTRONICS SPECIALISTS CONFERENCE. PESC 2002. CONFERENCE PROCEEDINGS. CAIRNS, QUEENSLAND, AUSTRALIA, JUNE 23 - 27, 2002; [ANNUAL POWER ELECTRONICS SPECIALISTS CONFERENCE], NEW YORK, NY : IEEE, US, vol. 2, 23 June 2002 (2002-06-23), pages 682-686, XP010747460 ISBN: 978-0-7803-7262-7 the whole document	1-3, 7-13, 17-25
X	DE 102 12 605 A1 (INFINEON TECHNOLOGIES AG [DE]) 16 October 2003 (2003-10-16) the whole document	1-4, 8-14, 18-25
X	US 2005/206361 A1 (ITO MASAHIKO [JP]) 22 September 2005 (2005-09-22) the whole document	1, 8-11, 18-20, 22-25

INTERNATIONAL SEARCH REPORT

Information on patent family members

International application No

PCT/US2008/062423

Patent document cited in search report		Publication date		Patent family member(s)	Publication date
US 2006221646	A1	05-10-2006	CN	1841893 A	04-10-2006
DE 10212605	A1	16-10-2003	NONE		
US 2005206361	A1	22-09-2005	JP	2005269736 A	29-09-2005