

E. S. YENTZER.

Sewing Machine.

No. 28.804.

Patented June 19, 1860.

Fig. 1

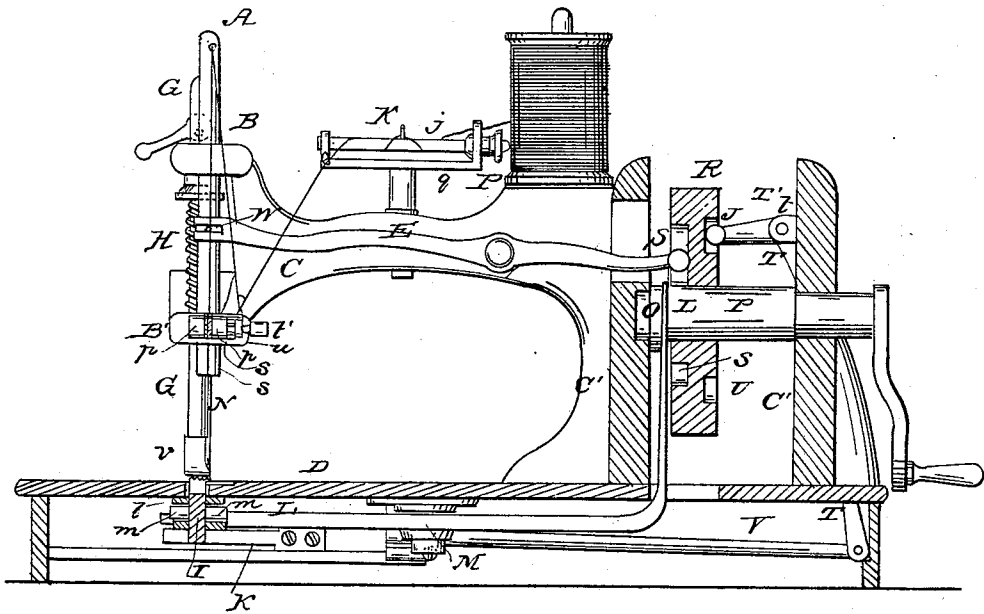
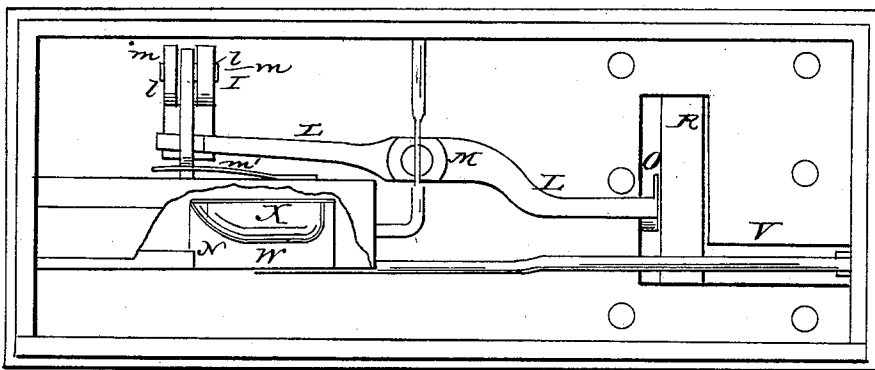

Fig. 3



Witnesses
 Goodwin & Ardee
 O. W. Henwick

Inventor
 E. S. Yentzer

E. S. YENTZER.
Sewing Machine.

No. 28,804.

Patented June 19, 1860.

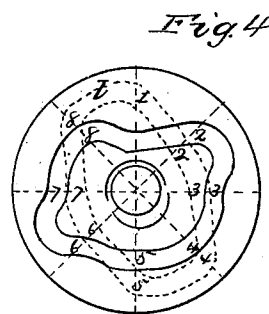
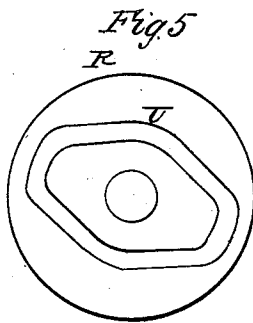
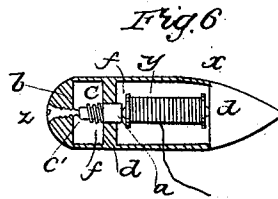
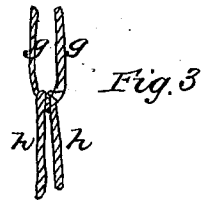
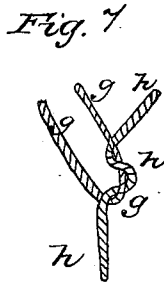
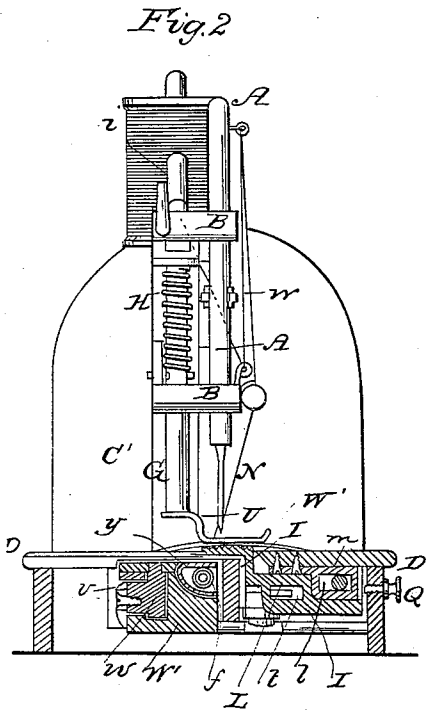

Witnesses
R. W. Hewick

Inventor
E. S. Yentzer

UNITED STATES PATENT OFFICE.

ENOCH S. YENTZER, OF MIDDLETOWN, PENNSYLVANIA.

IMPROVEMENT IN SEWING-MACHINES.

Specification forming part of Letters Patent No. 28,804, dated June 19, 1860.

To all whom it may concern:

Be it known that I, ENOCH S. YENTZER, of Middletown, in the county of Dauphin and State of Pennsylvania, have invented a new and useful Improvement in Sewing-Machines; and I do hereby declare that the following is a full, clear, and exact description of the same, reference being had to the accompanying drawings, forming a part of this specification, in which—

Figure 1 is a longitudinal vertical section of a sewing-machine constructed after my invention. Fig. 2 is a vertical transverse section of the same. Fig. 3 is a bottom view. Fig. 4 is a front view, and Fig. 5 a rear view, of the grooved cam. Fig. 6 is a vertical longitudinal section through the shuttle. Fig. 7 is a view of the stitch while being formed, and Fig. 8 a view of the same when complete.

Similar letters of reference in each of the several figures indicate corresponding parts.

To enable others skilled in the art to make and use my invention, I will proceed to describe its construction and operation.

The shaft P, to which are attached the cam-disk R and eccentric O, has its bearings in the upright portion C C' of the main frame of the machine. The disk R is provided with two cam-grooves, one, S, in its front face, and the other, U, in its rear face.

The rear end of a lever, E, which is pivoted to the main frame at F, works in the groove S of the cam-disk, while its front end supports the needle-carrier A, as seen at *w*. A peculiar motion is imparted to the rear end of lever E, and thus to the needle-carrier and needle N, by means of cam-groove S, as will be explained hereinafter.

An elbow-lever, T T', is fulcrumed at *t*, its upper end projecting into the cam-groove U, while its lower end, extending downward through a slot in the table D, is pivoted to the rear end of a rod, V. The front portion of rod V is formed into a piece, W, which partially encompasses the shuttle X, for the purpose of imparting to it the motion required. This motion, which is of course governed by the peculiar shape of the cam-groove U working the lever end T', and its relation to the motion of the needle—or, in other words, the peculiar re-

lation of the two cam-grooves to each other—will be described hereinafter.

The cloth-feeder I (provided with a rough surface projecting through a slot in the table D) has, near its end below the table, two pivots, *m m*, which play in slotted guide-pieces *l l*, which latter project from the bottom of the table. The cloth-feeder I has a slot, *l'*, through which the end of a lever, L, works in such a manner as to impart to the feeder the motion required for feeding the cloth. The width of the slot *l'* of the feeder is equal to the whole extent of the horizontal motion of the end of lever L, and thus the horizontal motion (which feeds the cloth forward) of the piece I can be stopped or graduated at will by adjusting the slot *l'* so that its width will correspond to the extent of motion of the lever end, or adjusting it more or less to one side of said motion of the lever end. In the latter case, it will be seen, the lever end will strike against one side of the slot, and thus impart a horizontal motion to the feeder I. These adjustments are made with a set-screw, Q, against the end of which the feeder I is pressed by means of a spring, *m'*; but the end of lever L has also a vertical motion, which, as the lever presses alternately against the upper or lower face of slot *l'*, causes the feeder I to rock on its pivots *m m*, which latter are at the same time free to slide in the horizontal guideways *ll*. This rocking motion causes the roughened surface of the feeder to rise and fall alternately, for the purpose of pressing against the cloth *w'* and pad *v*, or receding from it when feeding the cloth along.

The lever L is hung to the bottom of the table at M. Its rear end is bent upward and projects through a slot in the table, and terminates in a ring which embraces the eccentric O on shaft P, and thus the lever ends will receive a circular motion (or, in other words, a combined horizontal and vertical motion) at each revolution of the eccentric.

The needle-thread passes from the spool *i* around a small shaft, *j*, and hook *k*, projecting from said shaft, and thence to the needle-carrier and needle. This shaft *j* has its bearings in a standard, *g*, which is attached to the main frame, and one of its pivots is screw-threaded

and provided with a set-nut, *p*. When the set-nut is loose the shaft may be turned round more or less, so as to regulate the number of windings of the thread around the shaft.

It will be understood that the extent of thread in contact with the surface of the shaft, and consequently the friction between the two, will be increased as the number of turns given to the thread around the shaft are increased. Thus the tension of the thread may be regulated by turning the shaft *j*, and when properly adjusted the shaft may be fastened by screwing down the set-nut *p*. The thread, before it enters the needle-eye, passes between two pieces of wax or other suitable substance, *s s'*, which are attached to two knobs, *r r'*, respectively. The knob *r* projects from a plate attached to the main frame at *B'*, and is therefore stationary, while the other knob, *r'*, is adjustable by means of a screw, *t'*, which works through a screw-hole in a flange, *u*, extending from the said plate. By working the screw *t'* the knob *r'* and piece of wax *s'* can be moved more or less toward the stationary piece of wax *r*, so as to clamp the thread more or less tight between the two pieces of wax. It will be observed that the wax-holder is situated so that the thread is waxed after it has passed by the tension-shaft and loops, and therefore the thread is certain to pass through the cloth in a smooth condition. By this means the thread may be waxed as much as desired.

The other feature of my invention—the device employed for regulating the tension of the shuttle-thread—is constructed as follows: The pivot at one end of the bobbin *Y* has its bearing in the solid portion of the shuttle at *d*, while the other pivot bears against a small block, *a*, sliding through a corresponding hole in the shuttle-partition *f*. A short bar, *b*, extends from the block *a* backward, and a small spiral spring, *c*, winds around the bar, one end of the spring *c* resting against the rear surface of the partition *f*, the other end against a pin, *c'*, projecting from the bar. The tendency of this spring—the converse of what it is in springs generally used for producing the proper tension of the shuttle-thread—is to withdraw the block *a* from the pivot of the bobbin *Y* and allow the bobbin to be taken out when necessary. A screw, *Z*, works through a screw-hole in the rear end of the shuttle. The front end of this screw bears against the rear end of the bar extending from the pivot-block *a*.

It will be seen that the friction between the block and bobbin-pivot, and consequently the tension of the shuttle-thread, may be increased as much as may be requisite by screwing in the screw *Z*, so as to press the block *a* forward.

I will now proceed to describe the combined operation of the needle and shuttle.

For the purpose of producing the double lock-stitch represented in Figs. 7 and 8 of

the drawings, it is necessary that the needle should go twice through the same hole in the cloth, and that the shuttle should pass both times through the loop of the needle-thread. *g g g* in Fig. 7 represent the loop of the needle-thread, and *h h h* show the shuttle-thread after the shuttle has drawn it twice through the loop. The combined motions of needle, shuttle, and feed necessary for effecting this stitch are produced by one cam-disk, *R*, operating the levers *E* and *V*, and by the eccentric *O*, operating lever *L*.

Fig. 5 represents the two cam-grooves *S* and *U* and the eccentric *O* in their relative positions. During the position of the disk as represented in Fig. 4 the needle is at its greatest height, the shuttle is forward, and the rough surface of the feeder is raised up and partially forward. During the first one-eighth of a revolution of the disk, (in the direction of the arrow,) until the point 2 is at the top of the circumference of the disk, the needle enters the cloth, the shuttle moves back, and the feeding-surface drops down. During the next eighth of a revolution, until point 3 is on top, the needle penetrates the cloth and returns enough to form a loop, during which time the shuttle remains quiet and the feed-surface drops below the level of the table. During the next eighth of a revolution, until point 4 is on top, the shuttle passes through the loop, while the needle remains quiet. During the next eighth of a revolution, until 5 is on top, the shuttle is stationary, while the needle rises enough to allow the shuttle to move back under the loop. During this motion of the shuttle the needle remains stationary until point 6 is on top. During the next eighth of a revolution the needle penetrates the cloth again and returns sufficient to open the loop again, during which time the shuttle does not move. During the next eighth of a revolution, until point 8 is on top, the shuttle passes through the loop a second time, while the needle remains stationary. The feed-surface has in the meantime commenced to rise and begins to press against the cloth. During the last eighth of a revolution, until 1 is again on top, the needle withdraws out of the cloth and tightens the stitch, while the shuttle remains without motion, and the feed-surface presses tight against the cloth and moves the latter forward preparatory to the next stitch.

It will be seen that the shuttle-thread is tied twice in the same loop, and consequently the liabilities to rip are not so great as if it were tied only once.

What I claim as my invention, and desire to secure by Letters Patent, is—

1. The combination and arrangement of the horizontally-reciprocating shuttle *X*, vertically-reciprocating needle *N*, feed-pad *I*, disk *R*, (having cam-grooves *S U*, of the peculiar

configuration described, in its opposite faces,) eccentric O, lever E, lever T T', and lever L, the whole constructed and operating in the manner described, for the purpose of making the peculiar stitch represented in Figs. 7 and 8 of the drawings.

2. A shuttle (for sewing-machines) constructed with a sliding block, *a b*, spiral spring *c*, and set-screw *z*, the said parts being so arranged that a positive friction on the bobbin

Y is produced by the screw, and the action of the spring, when the screw is slackened, is to throw the block out of contact with the bobbin, substantially as and for the purposes set forth.

E. S. YENTZER.

Witnesses:

GOODWIN Y. AT LEE,
R. W. FENWICK.