



(12) **DEMANDE DE BREVET CANADIEN  
CANADIAN PATENT APPLICATION**

(13) **A1**

(86) Date de dépôt PCT/PCT Filing Date: 2020/05/21  
 (87) Date publication PCT/PCT Publication Date: 2020/12/03  
 (85) Entrée phase nationale/National Entry: 2021/11/15  
 (86) N° demande PCT/PCT Application No.: US 2020/033948  
 (87) N° publication PCT/PCT Publication No.: 2020/242873  
 (30) Priorité/Priority: 2019/05/30 (US62/854,368)

(51) Cl.Int./Int.Cl. *F04B 17/04* (2006.01),  
*F04B 49/06* (2006.01), *F04B 53/22* (2006.01),  
*H02K 33/10* (2006.01), *H02K 7/14* (2006.01)  
 (71) Demandeur/Applicant:  
MOTOR COMPONENTS, LLC, US  
 (72) Inventeurs/Inventors:  
DEPUE, MICHAEL ROBERT, US;  
SEAGER SR., KENNETH FRED, US  
 (74) Agent: CPST INTELLECTUAL PROPERTY INC.

(54) Titre : POMPE A CARBURANT  
 (54) Title: FUEL PUMP

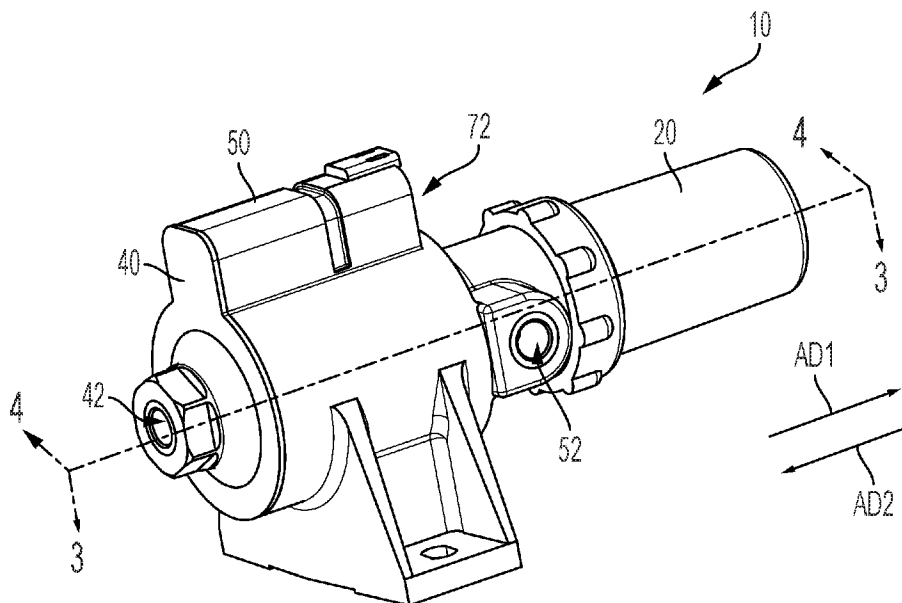

FIG. 1A

(57) **Abrégé/Abstract:**

A fuel pump, including a case, including a first section including a hub and a hole, a second section circumferentially arranged around the first section, wherein a radial space is arranged between the first section and the second section, an inlet in fluid communication with the radial space, a housing chamber arranged adjacent to the first section, and an outlet in fluid communication with the hole, a filter bowl removably connected to the second section, the filter bowl fluidly connecting the radial space with the hole, a valve assembly arranged at least partially in the first section and at least partially in the housing chamber, and a coil operatively arranged to apply a magnetic field to the valve assembly to selectively displace fluid therethrough.

(12) INTERNATIONAL APPLICATION PUBLISHED UNDER THE PATENT COOPERATION TREATY (PCT)

(19) World Intellectual Property  
Organization  
International Bureau



(10) International Publication Number  
**WO 2020/242873 A1**

(43) International Publication Date  
03 December 2020 (03.12.2020)

(51) International Patent Classification:

*F04B 17/04* (2006.01)      *F04B 49/03* (2006.01)  
*H02K 33/10* (2006.01)      *F04B 49/06* (2006.01)  
*F04B 35/04* (2006.01)

(72) Inventors: **DEPUE, Michael Robert**; 986 State Highway 12, Greene, New York 13778 (US). **SEAGER, SR., Kenneth Fred**; 23 Pine Street, Big Flats, New York 14814 (US).

(21) International Application Number:

PCT/US2020/033948

(74) Agent: **VРАНJES, Michael Nicholas et al.**; Simpson & Simpson, PLLC, 5555 Main Street, Suite 2, Buffalo, New York 14221 (US).

(22) International Filing Date:

21 May 2020 (21.05.2020)

(81) Designated States (*unless otherwise indicated, for every kind of national protection available*): AE, AG, AL, AM, AO, AT, AU, AZ, BA, BB, BG, BH, BN, BR, BW, BY, BZ, CA, CH, CL, CN, CO, CR, CU, CZ, DE, DJ, DK, DM, DO, DZ, EC, EE, EG, ES, FI, GB, GD, GE, GH, GM, GT, HN, HR, HU, ID, IL, IN, IR, IS, JO, JP, KE, KG, KH, KN, KP, KR, KW, KZ, LA, LC, LK, LR, LS, LU, LY, MA, MD, ME, MG, MK, MN, MW, MX, MY, MZ, NA, NG, NI, NO, NZ, OM, PA, PE, PG, PH, PL, PT, QA, RO, RS, RU, RW, SA, SC, SD, SE, SG, SK, SL, ST, SV, SY, TH, TJ, TM, TN, TR, TT, TZ, UA, UG, US, UZ, VC, VN, WS, ZA, ZM, ZW.

(25) Filing Language:

English

(26) Publication Language:

English

(30) Priority Data:

62/854,368      30 May 2019 (30.05.2019)      US

(71) Applicant: **MOTOR COMPONENTS, LLC** [US/US];  
2243 Corning Road, Elmira Heights, New York  
14903-1031 (US).

(54) Title: FUEL PUMP

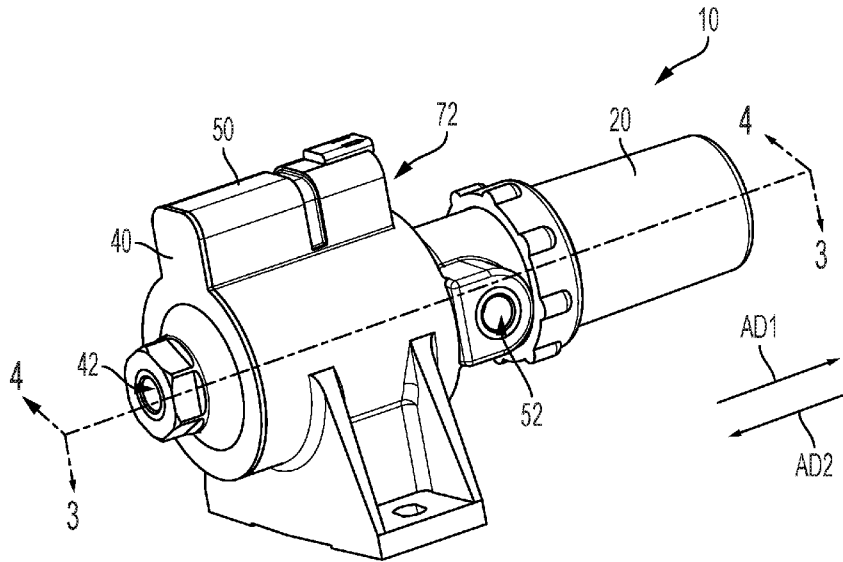

FIG. 1A

(57) Abstract: A fuel pump, including a case, including a first section including a hub and a hole, a second section circumferentially arranged around the first section, wherein a radial space is arranged between the first section and the second section, an inlet in fluid communication with the radial space, a housing chamber arranged adjacent to the first section, and an outlet in fluid communication with the hole, a filter bowl removably connected to the second section, the filter bowl fluidly connecting the radial space with the hole, a valve assembly arranged at least partially in the first section and at least partially in the housing chamber, and a coil operatively arranged to apply a magnetic field to the valve assembly to selectively displace fluid therethrough.



WO 2020/242873 A1

**WO 2020/242873 A1** 

**(84) Designated States** (*unless otherwise indicated, for every kind of regional protection available*): ARIPO (BW, GH, GM, KE, LR, LS, MW, MZ, NA, RW, SD, SL, ST, SZ, TZ, UG, ZM, ZW), Eurasian (AM, AZ, BY, KG, KZ, RU, TJ, TM), European (AL, AT, BE, BG, CH, CY, CZ, DE, DK, EE, ES, FI, FR, GB, GR, HR, HU, IE, IS, IT, LT, LU, LV, MC, MK, MT, NL, NO, PL, PT, RO, RS, SE, SI, SK, SM, TR), OAPI (BF, BJ, CF, CG, CI, CM, GA, GN, GQ, GW, KM, ML, MR, NE, SN, TD, TG).

**Published:**

— *with international search report (Art. 21(3))*

## FUEL PUMP

## 5 CROSS-REFERENCE TO RELATED APPLICATIONS

[0001] This application claims the benefit under Articles 4 and 8 of the Stockholm Act of the Paris Convention for the Protection of Industrial Property of U.S. Provisional Patent Application No. 62/854,368, filed on May 30, 2019, which application is hereby incorporated by reference in its entirety.

## 10 FIELD

[0002] The present disclosure relates to fuel pumps, and more particularly, to solenoid actuated fuel pumps.

## BACKGROUND

[0003] A fuel pump is a frequently (but not always) essential component on a car or other internal combustion engine device. Many engines (older motorcycle engines in particular) do not require any fuel pump at all, requiring only gravity to feed fuel from the fuel tank or under high pressure to the fuel injection system. Often, carbureted engines use low pressure mechanical pumps that are mounted outside the fuel tank, whereas fuel injected engines often use electric fuel pumps that are mounted inside the fuel tank (and some fuel injected engines have two fuel pumps: one low pressure/high volume supply pump in the tank and one high pressure/low volume pump on or near the engine). Fuel pressure needs to be within certain specifications for the engine to run correctly. If the fuel pressure is too high, the engine will run rough and rich, not combusting all of the fuel being pumped making the engine inefficient and a pollutant. If the pressure is too low, the engine may run lean, misfire, or stall.

25 [0004] Plunger-type pumps are a type of positive displacement pump that contain a pump chamber whose volume is increased and/or decreased by a plunger moving in and out of a chamber full of fuel with inlet and discharge stop-check valves. It is similar to that of a piston pump, but the high-pressure seal is stationary while the smooth cylindrical plunger slides through the seal. These pumps typically run at a higher pressure than diaphragm type pumps. A spring is

used to pull the plunger outward creating a lower pressure pulling fuel into the chamber from the inlet valve.

**[0005]** Typically, back pressure is present at the outlet port of a solenoid pump and limits operation of the pump, that is, the pump can operate only up to a certain back pressure level. In general, the back pressure works against the spring used to bias the plunger. For example, when the back pressure is greater than the biasing force of the spring, the pumping cycle is terminated (the plunger cannot return to a “rest” position when the coil is de-energized). The known use of linear springs limits the back pressure under which known solenoid pumps can operate. The spring biasing force must be relatively lower to enable the initiation of the plunger displacement when the coil is energized. Since the spring is linear, only the same relatively lower biasing force is available to counteract the back pressure. Known solenoid pumps cannot operate with a backpressure over about 10 psi.

**[0006]** Known solenoid pumps are difficult to assemble and can be large or bulky. Additionally, known solenoid pumps must be totally removed from its rather permanent plumbing in order that it be serviced (i.e., to replace the filter therein).

**[0007]** Thus, there is a long-felt need for a solenoid fuel pump that is compact, easy to assemble, and can be serviced without being removed from its plumbing. There is also a long-felt need for a solenoid pump, the timing of which can be controlled via a microcontroller and/or an external signal source. There is also a long-felt need for a solenoid pump that is entirely watertight and prevents the ingress of water and other foreign substances around the lead wires.

#### SUMMARY

**[0008]** According to aspects illustrated herein, there is provided a fuel pump, comprising a case, including a first section comprising a hub and a hole, a second section circumferentially arranged around the first section, wherein a radial space is arranged between the first section and the second section, an inlet in fluid communication with the radial space, a housing chamber arranged adjacent to the first section, and an outlet in fluid communication with the hole, a filter bowl removably connected to the second section, the filter bowl fluidly connecting the radial space with the hole, a valve assembly arranged at least partially in the first section and at least partially in the housing chamber, and a coil operatively arranged to apply a magnetic field to the valve assembly to selectively displace fluid therethrough.

[0009] In some embodiments, the fuel pump further comprises a bobbin arranged concentrically around the valve assembly, wherein the coil is arranged concentrically around the bobbin. In some embodiments, the fuel pump further comprises a first metal plate arranged on a first axial side of the coil, a second metal plate arranged on a second axial side of the coil, 5 opposite the first axial side, and a metal sleeve arranged circumferentially around the coil. In some embodiments, the fuel pump further comprises a circuit connected to the coil. In some embodiments, the circuit comprises a microcontroller operatively arranged to control current supplied to the coil. In some embodiments, the case further comprises a port electrically connected to the circuit. In some embodiments, the valve assembly comprises a fuel chamber 10 tube including a first end and a second end, a check valve assembly arranged in the fuel chamber tube at the first end, and a plunger assembly slidably arranged in the fuel chamber tube at the second end. In some embodiments, the check valve assembly comprises a first seat including a first side and a second side, a first component axially spaced from the first seat, a check valve displaceably arranged between the first seat and the first component, and a first spring 15 operatively arranged to bias the check valve in a first axial direction, towards the first seat. In some embodiments, the check valve assembly further comprises a seal, the seal being integrally formed and engaged with both the first side and the second side of the first seat. In some embodiments, the plunger assembly comprises a tube including a second seat, a third seat, and a through-bore, a fourth seat engaged with the second seat and including a radially inward facing 20 surface, a second component engaged with the second seat, and a plunger displaceably arranged between the fourth seat and the second component. In some embodiments, the check valve assembly further comprises a second spring arranged in a fuel chamber between the check valve assembly and the plunger assembly to bias the plunger assembly in a second axial direction, opposite the first axial direction. In some embodiments, the second spring is frusto-conical. In 25 some embodiments, when the plunger assembly is displaced in the first axial direction, the check valve sealingly engages the first side of the seat and the plunger is spaced apart from the radially inward facing surface allowing fluid flow into the through-bore, and when the plunger assembly is displaced in the second axial direction, the plunger is sealingly engaged with the radially inward facing surface and the check valve is spaced apart from the second surface allowing fluid 30 flow into the fuel chamber. In some embodiments, the fuel pump further comprises a filter

engaged with the hub, wherein the filter bowl is operatively arranged to secure the filter to the case.

**[0010]** According to aspects illustrated herein, there is provided a fuel pump, comprising a case, including a first section comprising a hub and a hole, a second section concentrically arranged around the first section, wherein a radial space is arranged between the first section and the second section, an inlet in fluid communication with the radial space, a housing chamber arranged adjacent to the first section and the second section, and an outlet in fluid communication with the hole, a filter bowl removably connected to the second section, the filter bowl fluidly connecting the radial space with the hole, a valve assembly arranged at least partially in the first section and at least partially in the housing chamber, the valve assembly including a fuel chamber tube comprising a first end and a second end, a check valve assembly arranged in the fuel chamber tube at the first end, and a plunger assembly slidingly arranged in the fuel chamber tube at the second end, and a solenoid coil concentrically arranged around the plunger assembly, the solenoid coil operatively arranged to produce a magnetic field to displace the plunger assembly in a first axial direction such that fluid is selectively displaced from the inlet to the outlet.

**[0011]** In some embodiments, the fuel pump further comprises a circuit connected to the solenoid coil, the circuit comprising a microcontroller operatively arranged to control power supplied to the solenoid coil. In some embodiments, the check valve assembly comprises a first seat including a first side and a second side, a seal integrally formed and engaged with both the first side and the second side, a first component axially spaced from the first seat, a check valve displaceably arranged between the first seat and the first component, and a first spring operatively arranged to bias the check valve in the first axial direction, towards the first seat. In some embodiments, the plunger assembly comprises a tube including a through-bore, a second seat engaged with the tube and including a radially inward facing surface, a second component engaged with the tube, and a plunger displaceably arranged between the second seat and the second component, wherein a spring is arranged between the plunger assembly and the check valve assembly to bias the plunger assembly in a second axial direction, opposite the first axial direction. In some embodiments, when the plunger assembly is displaced in the first axial direction, the check valve sealingly engages the first side and the plunger is spaced apart from

the radially inward facing surface allowing fluid flow into the through-bore, and when the plunger assembly is displaced in the second axial direction, the plunger is sealingly engaged with the radially inward facing surface and the check valve is spaced apart from the second surface allowing fluid flow into the fuel chamber tube.

5 **[0012]** According to aspects illustrated herein, there is provided a fuel pump, comprising a case, including a first section comprising a hub and a hole, a second section concentrically arranged around the first section, wherein a radial space is arranged between the first section and the second section, an inlet in fluid communication with the radial space, a housing chamber arranged adjacent to the first section and the second section, and an outlet in fluid  
10 communication with the hole, a filter removably connected to the hub, a filter bowl removably connected to the second section and operatively arranged to secure the filter to the case, the filter bowl fluidly connecting the radial space with the hole, a valve assembly arranged at least partially in the first section and at least partially in the housing chamber, the valve assembly including a fuel chamber tube comprising a first end and a second end, a check valve assembly  
15 arranged in the fuel chamber tube at the first end, and a plunger assembly slidingly arranged in the fuel chamber tube at the second end, and a solenoid coil concentrically arranged around the plunger assembly, the solenoid coil operatively arranged to produce a magnetic field to displace the plunger assembly in a first axial direction such that fluid is selectively displaced from the inlet to the outlet.

20 **[0013]** These and other objects, features, and advantages of the present disclosure will become readily apparent upon a review of the following detailed description of the disclosure, in view of the drawings and appended claims.

#### BRIEF DESCRIPTION OF THE DRAWINGS

**[0014]** Various embodiments are disclosed, by way of example only, with reference to  
25 the accompanying schematic drawings in which corresponding reference symbols indicate corresponding parts, in which:

Figure 1A is a perspective view of a fuel pump;

Figure 1B is a perspective view of the fuel pump shown in Figure 1A;

Figure 2 is an exploded perspective view of the fuel pump shown in Figure 1A;

Figure 3 is a cross-sectional view of the fuel pump taken generally along line **3-3** in Figure 1A;

Figure 4 is a cross-sectional view of the fuel pump taken generally along line **4-4** in Figure 1A;

5 Figure 5 is a perspective view of a valve assembly;

Figure 6 is a cross-sectional view of the valve assembly taken generally along line **6-6** in Figure 5;

Figure 7 is an exploded perspective view of the valve assembly shown in Figure 5; and,

Figure 8 is a detail view of the valve assembly taken generally along detail **8** in Figure 6.

10

#### DETAILED DESCRIPTION

**[0015]** At the outset, it should be appreciated that like drawing numbers on different drawing views identify identical, or functionally similar, structural elements. It is to be understood that the claims are not limited to the disclosed aspects.

15 **[0016]** Furthermore, it is understood that this disclosure is not limited to the particular methodology, materials and modifications described and as such may, of course, vary. It is also understood that the terminology used herein is for the purpose of describing particular aspects only, and is not intended to limit the scope of the claims.

20 **[0017]** Unless defined otherwise, all technical and scientific terms used herein have the same meaning as commonly understood to one of ordinary skill in the art to which this disclosure pertains. It should be understood that any methods, devices or materials similar or equivalent to those described herein can be used in the practice or testing of the example embodiments. The assembly of the present disclosure could be driven by hydraulics, electronics, pneumatics, and/or springs.

25 **[0018]** It should be appreciated that the term “substantially” is synonymous with terms such as “nearly,” “very nearly,” “about,” “approximately,” “around,” “bordering on,” “close to,” “essentially,” “in the neighborhood of,” “in the vicinity of,” etc., and such terms may be used interchangeably as appearing in the specification and claims. It should be appreciated that the term “proximate” is synonymous with terms such as “nearby,” “close,” “adjacent,” “neighboring,” “immediate,” “adjoining,” etc., and such terms may be used interchangeably as

appearing in the specification and claims. The term “approximately” is intended to mean values within ten percent of the specified value.

**[0019]** By “non-rotatably connected” or “non-rotatably secured” elements, we mean that: the elements are connected so that whenever one of the elements rotate, all the elements rotate; and relative rotation between the elements is not possible. Radial and/or axial movement of non-rotatably connected elements with respect to each other is possible, but not required. By “rotatably connected” elements, we mean that the elements are rotatable with respect to each other.

**[0020]** Moreover, as used herein, “and/or” is intended to mean a grammatical conjunction used to indicate that one or more of the elements or conditions recited may be included or occur. For example, a device comprising a first element, a second element and/or a third element, is intended to be construed as any one of the following structural arrangements: a device comprising a first element; a device comprising a second element; a device comprising a third element; a device comprising a first element and a second element; a device comprising a first element and a third element; a device comprising a first element, a second element and a third element; or, a device comprising a second element and a third element.

**[0021]** Adverting now to the figures, Figure 1A is a perspective view of fuel pump **10**. Figure 1B is a perspective view of fuel pump **10**. Figure 2 is a exploded perspective view of fuel pump shown **10**. Figure 3 is a cross-sectional view of fuel pump **10** taken generally along line **3-3** in Figure 1A. Figure 4 is a cross-sectional view of fuel pump **10** taken generally along line **4-4** in Figure 1A. Fuel pump **10** generally comprises filter bowl **20**, filter **26**, cover **40**, case **50**, circuit or circuit board **80**, coil **152**, and valve assembly **90**. The following description should be read in view of Figures 1A-4.

**[0022]** Filter bowl **20** comprises hub **22** and threading **24**. Filter bowl **20** is operatively arranged to secure filter **26** to case **50**. In some embodiments, and as shown, filter bowl **20** is connected to case **50** via threading **24**. Threading **24** engages threading **58** of case **50**. When filter bowl **20** is connected to case **50**, filter **26** is secured between hub **22** and case **50**. Specifically, filter **26** engages hub **22** of filter bowl **20** and hub **62** of case **50** to ensure proper alignment and position of filter **26**. As shown in Figures 3 and 4, filter **26** is positioned circumferentially around hub **22** and hub **62** (i.e., filter **26** is a sleeve that is slid over hub **62** and

hub 22 at each end). In some embodiments, filter 26 comprises support cage 28. In such embodiments, filter 26 and support cage 28 engage hub 22 of filter bowl 20 and hub 62 of case 50 to ensure proper alignment and position of filter 26. In some embodiments, filter bowl 20 is transparent, which allows filter 26 to be seen so as to indicate when replacement is necessary. In some embodiments, filter bowl 20 is translucent. In some embodiments, filter bowl 20 is opaque. Filter bowl 20 and filter 26 are operatively arranged to be removably connected to case 50. The threaded connection between filter bowl 20 and case 50 allow for easy replacement of filter 26.

[0023] Case 50 comprises inlet 52, section 56, section 60, fuel chamber 68, and housing chamber 70. Space 64 is a radially space arranged radially between section 56 and section 60. Sections 56 and 60 are generally radial walls. Section 60 comprises hub 62, which is operatively arranged to engage filter 26, hole 66, and fuel chamber 68. In some embodiments, section 60 is frusto-conical (i.e., section 60 decreases in diameter in axial direction AD1). Section 56 is arranged radially outward of, and circumscribes, section 60. Section 56 comprises threading 58, which is arranged to threadably engage threading 24 to connect filter bowl 20 with case 50. In some embodiments, inlet 52 comprises fitting 54. In some embodiments, a longitudinal axis of inlet 52 is perpendicular to a longitudinal axis of hole 66 and outlet 42. In some embodiments, a longitudinal axis of inlet 52 is arranged at an angle with respect to a longitudinal axis of hole 66 and outlet 42, and that angle being greater than 0 degrees and less than 180 degrees. In some embodiments, fitting 54 is a metal insert and includes threading on a its radially inward facing surface. In some embodiments, fitting 54 is molded within outlet 52. In some embodiments, a seal is arranged around fitting 54 to create a seal between fitting 54 and case 50. Housing chamber 70 is arranged adjacent to fuel chamber 68. Fuel chamber 68 at least partially houses valve assembly 60. In some embodiments, seal 94A is arranged radially between valve assembly 90 and section 56. Housing chamber 70 at least partially houses valve assembly 60. Housing chamber 70 houses circuit 80, coil bobbin 150, coil 152, pole 154, and pole 156. Case 50 further comprises connector port 72 which allows an electrical connection between a power source and circuit 80, and coil 152. In some embodiments, connector port 72 may comprise a connector geometry that eliminates the need for external lead wires, for example, Deutsch connector P/N: DT04-4P. This connector geometry is arranged in such a way as to accept the connector pins,

namely, terminal(s) **82**, from circuit **80** that will be described in greater detail below. In some embodiments, case **50** is injection molded.

**[0024]** Cover **40** comprises outlet **42**, protrusion **44**, and recess or hole **46**. Cover **40** is operatively arranged to be connected to case **50** to secure various components of fuel pump **10** therein. In some embodiments, cover **40** is connected to case **50** via ultrasonic weld; however, it should be appreciated that any suitable method for connecting cover **40** and case **50** may be used, for example, adhesives, bolts, screws, rivets, pins, nails, welding, soldering, etc. Protrusion **44** extends at least partially into housing chamber **70**, in axial direction **AD1**, and at least partially engages valve assembly **90** via recess **46**, which aligns valve assembly **90** with outlet **42**. In some  
10 embodiments, outlet **42** comprises fitting **48**. In some embodiments, fitting **48** is a metal insert and includes threading on a its radially inward facing surface. In some embodiments, fitting **48** is molded within outlet **42**. In some embodiments, a seal is arranged around fitting **48** to create a seal between fitting **48** and cover **40**. In some embodiments, seal **94B** is radially arranged between recess **46** and valve assembly **90**. In some embodiments, protrusion **44** engages shoulder  
15 **98**. Shoulder **98** engages spring **96** to bias the electromagnet portion of fuel pump **10** in axial direction **AD1**. For example, spring **96** is arranged axially between shoulder **98** and pole **154** to maintain the proper positioning of coil bobbin **150**, coil **152**, pole **154**, and pole **156** in housing chamber **70**. In some embodiments, cover **40** is injection molded.

**[0025]** To assemble fuel pump **10**, filter **26** is arranged on hub **62** and filter bowl **20** is connected to section **56**, for example, via threading **24** and threading **58**. Valve assembly **90** is positioned within fuel chamber **68** and housing chamber **70**. The solenoid coil assembly, namely, coil bobbin **150**, coil **152**, pole **154**, pole **156**, and sleeve **158** are arranged in housing chamber **70**, concentrically or radially around valve assembly **90**. Circuit **80** is arranged in housing chamber **70**, along with respective terminal(s) **82** and/or terminal(s) **84**. In some embodiments,  
25 circuit **80** engages retainer **151** of coil bobbin **150**. In some embodiments, spring **96** and shoulder **98** are arranged on valve assembly **90**. In some embodiments, all of the components within case **50** are then secured therein with epoxy. Then cover **40** is connected to case **50**. In some embodiments, when fuel pump **10** is fully assembled it is hermetically sealed.

**[0026]** The electromagnetic portion of the pump comprises coil bobbin **150**, coil **152**  
30 arranged circumferentially around coil bobbin **150**, pole **154** arranged on a first axial side of coil

bobbin, pole **156** arranged on a second axial side of coil bobbin, and sleeve **158** arranged circumferentially around coil **152**. In some embodiments, coil bobbin **150** comprises a polymer and houses solenoid coil **152**. As is known in the art, a coil or solenoid or solenoid coil is a type of electromagnet the purpose of which is to generate a controlled magnetic field through a coil wound into a tightly packed helix. Thus, coil **152** is wound as a helix around coil bobbin **150**, and also plunger assembly **120**. When electric current is passed through coil **152**, a magnetic field is produced, which in the present disclosure, then displaces plunger assembly **120** in axial direction **AD1** within fuel chamber tube **92** (i.e., plunger assembly **120** is slidably arranged in fuel chamber tube **92**). Since plunger assembly **120** comprises a magnetic metal (e.g., 416 stainless steel), it reacts to the magnetic field created by coil **152** (i.e., coil **152** creates a magnetic field which attracts, or opposes, the polarity of plunger assembly **120**, specifically tube **122**) as will be described in greater detail below. The poles **154** and **156**, and sleeve **158** completely surround coil **152** in order to further direct the magnetic field toward plunger assembly **120**. Specifically, pole **154** is a metal magnetic pole arranged axially adjacent to coil bobbin **150**, pole **156** is a metal magnetic pole arranged axially adjacent to coil bobbin **150**, and sleeve **158** is a metal magnetic sleeve arranged circumferentially around coil **152**. Coil **152** is connected to two or more terminals **84**. Terminals **84** are connected to circuit **80**. In some embodiments, and as shown in the figures, each end of coil **152** is connected to a respective terminal **84** by way of a small helical coil (see Figure 3). The ends of coil **152** extend out of coil bobbin **150**, through an aperture in pole **154**, and engage their respective terminals **84**. In some embodiments, coil bobbin **150** further comprises retainer **151** which extends therefrom in axial direction **AD2**. Retainer **151** extends through an aperture in pole **154** and engages an aperture in circuit **80** in order to further secure circuit **80** to coil bobbin **150** (in addition to the connection via terminals **84** and coil **152**).

**[0027]** Circuit **80** is arranged around valve assembly **90** within housing chamber **70**. In some embodiments, circuit **80** comprises a circuit board. Terminals **84** are connected to circuit **80**, for example, via solder. In some embodiments, circuit **80** comprises one or more terminals **82**. For example, circuit **80** may have three connector terminals **82**, with two of the three terminals being used to supply electricity to circuit **80** and coil **152**, and the third terminal being used to supply a signal to circuit **80** from an external signal source to externally control when

and for how long current is supplied to circuit **80** (i.e., without the use of or in addition to a microcontroller). Terminals **82** are connected to circuit **80**, for example, via solder, and are aligned with connector port **72**. Terminals **82** allow electrical connection with an external electrical connector via port **72**. In some embodiments, terminals **84**, circuit **80**, and terminals **82** (and their connection to an external signal source, provide electrical current to coil **152**. In some 5 embodiments, circuit **80** comprises transistor **88**. In some embodiments, transistor **88** connects the circuit to ground thereby allowing current to run through coil **152**. In some embodiments, circuit **80** further comprises one or more microcontrollers. The microcontroller is operatively arranged to control circuit timing, for example, how long and when current is provided to coil 10 **152**. The microcontroller may also control the amount of voltage provided to coil **152**. For example, the purpose of coil **152** and circuit **80** is to displace plunger assembly **120** with enough axial distance in order to pump a proper amount of fuel. To do this, there are two variables that might be considered: 1) the amount of time current is provided to coil **152** and 2) the amount of voltage provided to coil **152**. For example, if a large amount of voltage is applied to coil **152**, a large magnetic field will be produced and displace plunger assembly **120** a sufficient distance in 15 a very short amount of time. If a low amount of voltage is applied to coil **152**, the same sufficient displacement distance of plunger assembly **120** may still be achieved but will require that current be provided to coil **152** for a longer amount of time. The microcontroller is programmed to control these variables based on the provided voltage levels. In some embodiments, the microcontroller shuts down coil **152** (i.e., stops voltage applied to coil **152**) if the input voltage 20 exceeds a predetermined amount, for example, 18 Volts. As shown in the drawings, and specifically Figures 3 and 4, coil bobbin **150**, coil **152**, poles **154** and **156**, sleeve, circuit **80**, spring **96**, and shoulder **98** are all arranged concentrically around valve assembly **90** (i.e., valve assembly **90** runs through, for example apertures in, each of coil bobbin **150**, coil **152**, poles **154** and **156**, sleeve, circuit **80**, spring **96**, and shoulder **98**). 25

**[0028]** Fuel enters fuel pump **10** through inlet **52** and enters space or chamber **64**. The fuel then exits space **64** in axial direction **AD1** and follows flow path **FP1** through filter **26** (i.e., radially inward). Fuel then enters fuel chamber **68**, specifically fuel chamber **94** of valve assembly **90**, through hole **66** in section **60**, in axial direction **AD2**. Fuel travels in axial direction

**AD2** through valve assembly **90** and exits fuel pump **10** through outlet **42**. The displacement of fuel through valve assembly **90** will be described in greater detail below.

[0029] Figure 5 is a perspective view of valve assembly **90**. Figure 6 is a cross-sectional view of valve assembly **90** taken generally along line **6-6** in Figure 5. Figure 7 is an exploded perspective view of valve assembly **90**. Figure 8 is a detailed view of valve assembly **90** taken generally along detail **8** in Figure 6. Valve assembly **90** generally comprises fuel chamber tube **94**, check valve assembly **100**, spring **114**, plunger assembly **120**, and spring **144**. The following description should be read in view of Figures 1A-8.

[0030] Check valve assembly **100** is operatively arranged to selectively allow fuel to flow into fuel chamber **94** in axial direction **AD1**. Check valve assembly **100** is arranged at a first end of fuel chamber tube **92** and comprises seat **102**, seal **104**, check valve **106**, spring **110**, and component **112**. Seat **102** comprises first axial side **102A** and second axial side **102B**. Seal **104** engages both axial sides of seat **102**. Specifically, and as shown in Figure 6, seal **104** is arranged adjacent to side **102A**, wraps around a radially inward facing surface (through-bore) of seat **102**, and is also arranged adjacent to side **102B**. As such, seal **104** provides sealing engagement of seat **102** with section **60** of case **50**, as well as sealing engagement of check valve **106**, specifically surface **106A**, with seat **102**. Check valve **106** is operatively arranged to displace in axial direction **AD1** and axial direction **AD2** to allow passage of fuel into fuel chamber **94**, as indicated by flow path **FP2**. Check valve **106** comprises surface **106A**, which is operatively arranged to sealingly engage with surface **102B** via seal **104**, and protrusion **108**, which is operatively arranged to engage spring **110**. Spring **110** biases check valve **106** into sealing engagement with seat **102**. Component **112** engages spring **110**. In some embodiments, spring **110** wraps concentrically around protrusion **108** and sits within an indentation in component **112**. Component **112** and spring **110** work together to bias check valve **106** in axial direction **AD1**. In some embodiments, component **112** is connected to seat **102**. Component **112** has a plurality of fingers that connect to seat **102** and allow for fluid to flow through component **112** in axial direction **AD2**. Spring **114** engages component **112** at a first end and seat **130** at a second end. Spring **114** is operatively arranged to bias plunger assembly **120** in axial direction **AD2**, as will be described in greater detail below. In some embodiments, spring **114** is frusto-conical. In some embodiments, spring **114** is a constant diameter helical spring.

[0031] Plunger assembly 120 is operatively arranged to selectively allow fuel to flow into through-bore 124 in axial direction AD1. Plunger assembly 120 is arranged at a second end of fuel chamber tube 92, opposite check valve assembly 100, and comprises tube 122, seat 130, component 134, plunger 138, and spring 144. As previously described, plunger assembly 120, specifically tube 122, comprises a magnetic metal (e.g., 416 stainless steel) that displaces relative to the magnetic field created by coil 152. Tube 122 comprises through-bore 124, seat 126, and seat 128. Seat 130 has a cylindrical portion and flange portion that extend radially inward from the cylindrical portion on a first end of the cylindrical portion. The second end of the cylindrical portion engages seat 126. In some embodiments, seat 130 is generally shaped like a brake drum of an automobile. Seat 130 comprises surface 132 which is arranged to engage plunger 138 to create a seal therebetween. Component 134 is arranged to engage seat 126. As shown in Figure 7, component 134 is triangular shaped having a through-bore and curved radially outward facing surface apertures therein. Plunger 138 is generally arranged between seat 130 and component 134 and is connected to shaft 140 which is engaged with the through-bore of component 134. In a sealed state, plunger 138 is engaged with surface 132, thereby preventing fuel from entering through-bore 124 from fuel chamber 94. In an unsealed state, plunger 138 displaces away from surface 132 in axial direction AD2 with respect to seat 130 and component 134, thereby allowing fuel to flow through seat 130 and component 134 into through-bore 124, as indicated by flow path FP3 in Figure 6. In some embodiments, a spring is arranged between component 134 and plunger 138 to bias plunger 138 into engagement with surface 132. Spring 144 is arranged to engage seat 128 at a first end, and recess 46 of cover 40 at a second end. Spring 144 is arranged to dampen the return displacement of tube 122. For example, when current provided to coil 152 is turned off, spring 114 displaces tube 122 in axial direction AD2. Spring 144 provides a buffer between tube 122 and cover 40, thereby preventing tube 122 from impacting the solid material of cover 40 and possibly damaging it.

[0032] When direct current (DC) power is applied to circuit 80 via terminals 82, the microcontroller on circuit 80 causes DC power to flow through coil 152 at frequencies that vary with the input voltage. One complete cycle of fuel pump 10 begins with circuit 80 causing one coil lead, namely, one of terminals 84, to be connected to ground through transistor 88. Coil 152, enhanced by the metal shielding surrounding it, namely, magnetic poles 154 and 156 and

magnetic sleeve **158**, urges plunger assembly, namely tube **122**, in axial direction **AD1** (i.e., towards filter bowl **20**). During this movement, check valve assembly **100** is closed (i.e., surface **106A** of check valve **106** is sealingly engaged with seat **102**), plunger assembly **120** is open (i.e., plunger **138** is not sealingly engaged with surface **132**), and fuel flows through seat **130**, around  
5 plunger **138**, through component **134**, and into through-bore **124** as indicated by flow path **FP3** in Figure 6. It is the displacement of tube **122** in axial direction **AD1** that forces plunger **138** off of surface **132** of seat **130**, thereby allowing fuel to flow from fuel chamber **94** and into through-bore **124**. Circuit **80** then disconnects the coil lead from ground causing the DC current to stop flowing through coil **152** and results in the collapse of the magnetic field. Spring **114** urges tube  
10 **122** and plunger assembly **120** in axial direction **AD2** back toward its initial position, as shown in Figures 3 and 4. This movement, in axial direction **AD2**, causes check valve assembly **100** to open (i.e., surface **106A** of check valve **106** disengages seat **102**) allowing fuel to flow into fuel chamber **94** as indicated by flow path **FP2**, and plunger assembly **120** to close (i.e., plunger **138** sealingly engages surface **132** of seat **130**). The fuel on the outlet side of plunger **138** (i.e., within  
15 and adjacent to through-bore **124**) is forced towards outlet **42**. Fuel in filter bowl **20** and filter **26** is pulled into fuel chamber **94** (i.e., via vacuum). Thus, displacement of plunger assembly **120** in axial direction **AD1** via a magnetic force moves fuel from fuel chamber **94** into through-bore **124**. Displacement of plunger assembly **120** in axial direction **AD2** when the magnetic force is removed displaces fuel from through-bore **124** through outlet **42** as well as from filter bowl **20**  
20 into fuel chamber **94**. This cycle is repeated at predetermined frequencies programmed into the microcontroller or manually operated via an external signal source.

[0033] It should be appreciated that the arrangement of fuel pump **10** allows filter **26** to be serviced without having to remove the plumbing connections at inlet **52** and outlet **42**. It should also be appreciated that, while the present disclosure is directed at a pump for fuel, the  
25 fuel pump of the present disclosure can be used with any fluids in need of pumping, for example, water, paint, oil, etc., and the term “fuel” as used herein is intended to be synonymous with the term “fluid.”

[0034] It will be appreciated that various aspects of the disclosure above and other features and functions, or alternatives thereof, may be desirably combined into many other  
30 different systems or applications. Various presently unforeseen or unanticipated alternatives,

modifications, variations, or improvements therein may be subsequently made by those skilled in the art which are also intended to be encompassed by the following claims.

## LIST OF REFERENCE NUMERALS

	<b>10</b>	Fuel pump		<b>92</b>	Fuel chamber tube
	<b>20</b>	Filter		<b>94</b>	Fuel chamber
5	<b>22</b>	Hub		<b>100</b>	Check valve assembly
	<b>24</b>	Threading		<b>102</b>	Seat
	<b>26</b>	Filter	35	<b>102A</b>	Side
	<b>28</b>	Cage		<b>102B</b>	Side
	<b>30</b>	Seal		<b>104</b>	Seal
10	<b>40</b>	Cover		<b>106</b>	Check valve
	<b>42</b>	Outlet		<b>106A</b>	Surface
	<b>44</b>	Protrusion	40	<b>108</b>	Protrusion
	<b>46</b>	Recess or hole		<b>110</b>	Spring
	<b>48</b>	Fitting		<b>112</b>	Component
15	<b>50</b>	Case		<b>114</b>	Spring
	<b>52</b>	Inlet		<b>120</b>	Plunger assembly
	<b>54</b>	Fitting	45	<b>122</b>	Tube
	<b>56</b>	Section		<b>124</b>	Through-bore
	<b>58</b>	Threading		<b>126</b>	Seat
20	<b>60</b>	Section		<b>128</b>	Seat
	<b>62</b>	Hub		<b>130</b>	Seat
	<b>64</b>	Space or chamber	50	<b>132</b>	Surface
	<b>66</b>	Hole		<b>134</b>	Component
	<b>68</b>	Fuel chamber		<b>136</b>	Surface
25	<b>70</b>	Housing chamber		<b>138</b>	Plunger
	<b>72</b>	Connector port		<b>140</b>	Shaft
	<b>80</b>	Circuit	55	<b>142</b>	Surface
	<b>82</b>	Terminal(s)		<b>144</b>	Spring
	<b>84</b>	Terminal(s)		<b>150</b>	Coil bobbin
30	<b>90</b>	Valve assembly		<b>151</b>	Retainer

<b>152</b>	Coil	<b>FP2</b>	Flow path
<b>154</b>	Pole	<b>FP3</b>	Flow path
<b>156</b>	Pole	<b>AD1</b>	Axial direction
<b>158</b>	Sleeve	<b>AD2</b>	Axial direction
5 <b>FP1</b>	Flow path		

10

## CLAIMS

What Is Claimed Is:

1. A fuel pump, comprising:  
a case, including:
  - a first section comprising a hub and a hole;
  - a second section circumferentially arranged around the first section, wherein a radial space is arranged between the first section and the second section;
  - an inlet in fluid communication with the radial space;
  - a housing chamber arranged adjacent to the first section; and,
  - an outlet in fluid communication with the hole;a filter bowl removably connected to the second section, the filter bowl fluidly connecting the radial space with the hole;  
a valve assembly arranged at least partially in the first section and at least partially in the housing chamber; and,  
a coil operatively arranged to apply a magnetic field to the valve assembly to selectively displace fluid therethrough.
2. The fuel pump as recited in Claim 1, further comprising a bobbin arranged concentrically around the valve assembly, wherein the coil is arranged concentrically around the bobbin.
3. The fuel pump as recited in Claim 2, further comprising:
  - a first metal plate arranged on a first axial side of the coil;
  - a second metal plate arranged on a second axial side of the coil, opposite the first axial side; and,
  - a metal sleeve arranged circumferentially around the coil.
4. The fuel pump as recited in Claim 1, further comprising a circuit connected to the coil.

5. The fuel pump as recited in Claim 4, wherein the circuit comprises a microcontroller operatively arranged to control current supplied to the coil.
6. The fuel pump as recited in Claim 4, wherein the case further comprises a port electrically connected to the circuit.
7. The fuel pump as recited in Claim 1, wherein the valve assembly comprises:
  - a fuel chamber tube including a first end and a second end;
  - a check valve assembly arranged in the fuel chamber tube at the first end; and,
  - a plunger assembly slidably arranged in the fuel chamber tube at the second end.
8. The fuel pump as recited in Claim 7, wherein the check valve assembly comprises:
  - a first seat including a first side and a second side;
  - a first component axially spaced from the first seat;
  - a check valve displaceably arranged between the first seat and the first component; and,
  - a first spring operatively arranged to bias the check valve in a first axial direction, towards the first seat.
9. The fuel pump as recited in Claim 8, wherein the check valve assembly further comprises a seal, the seal being integrally formed and engaged with both the first side and the second side of the first seat.
10. The fuel pump as recited in Claim 8, wherein the plunger assembly comprises:
  - a tube including a second seat, a third seat, and a through-bore;
  - a fourth seat engaged with the second seat and including a radially inward facing surface;
  - a second component engaged with the second seat; and,
  - a plunger displaceably arranged between the fourth seat and the second component.
11. The fuel pump as recited in Claim 10, wherein the check valve assembly further comprises a second spring arranged in a fuel chamber between the check valve assembly and the

plunger assembly to bias the plunger assembly in a second axial direction, opposite the first axial direction.

12. The fuel pump as recited in Claim 11, wherein the second spring is frusto-conical.

13. The fuel pump as recited in Claim 11, wherein:

when the plunger assembly is displaced in the first axial direction, the check valve sealingly engages the first side of the seat and the plunger is spaced apart from the radially inward facing surface allowing fluid flow into the through-bore; and,

when the plunger assembly is displaced in the second axial direction, the plunger is sealingly engaged with the radially inward facing surface and the check valve is spaced apart from the second surface allowing fluid flow into the fuel chamber.

14. The fuel pump as recited in Claim 1, further comprising a filter engaged with the hub, wherein the filter bowl is operatively arranged to secure the filter to the case.

15. A fuel pump, comprising:

a case, including:

a first section comprising a hub and a hole;

a second section concentrically arranged around the first section, wherein a radial space is arranged between the first section and the second section;

an inlet in fluid communication with the radial space;

a housing chamber arranged adjacent to the first section and the second section;

and,

an outlet in fluid communication with the hole;

a filter bowl removably connected to the second section, the filter bowl fluidly connecting the radial space with the hole;

a valve assembly arranged at least partially in the first section and at least partially in the housing chamber, the valve assembly including:

a fuel chamber tube comprising a first end and a second end;

a check valve assembly arranged in the fuel chamber tube at the first end; and,  
a plunger assembly slidingly arranged in the fuel chamber tube at the second end;  
and,

a solenoid coil concentrically arranged around the plunger assembly, the solenoid coil operatively arranged to produce a magnetic field to displace the plunger assembly in a first axial direction such that fluid is selectively displaced from the inlet to the outlet.

16. The fuel pump as recited in Claim 15, further comprising a circuit connected to the solenoid coil, the circuit comprising a microcontroller operatively arranged to control power supplied to the solenoid coil.

17. The fuel pump as recited in Claim 15, wherein the check valve assembly comprises:  
a first seat including a first side and a second side;  
a seal integrally formed and engaged with both the first side and the second side;  
a first component axially spaced from the first seat;  
a check valve displaceably arranged between the first seat and the first component; and,  
a first spring operatively arranged to bias the check valve in the first axial direction, towards the first seat.

18. The fuel pump as recited in Claim 17, wherein the plunger assembly comprises:  
a tube including a through-bore;  
a second seat engaged with the tube and including a radially inward facing surface;  
a second component engaged with the tube; and,  
a plunger displaceably arranged between the second seat and the second component;  
wherein a spring is arranged between the plunger assembly and the check valve assembly to bias the plunger assembly in a second axial direction, opposite the first axial direction.

19. The fuel pump as recited in Claim 18, wherein:

when the plunger assembly is displaced in the first axial direction, the check valve sealingly engages the first side and the plunger is spaced apart from the radially inward facing surface allowing fluid flow into the through-bore; and,

when the plunger assembly is displaced in the second axial direction, the plunger is sealingly engaged with the radially inward facing surface and the check valve is spaced apart from the second surface allowing fluid flow into the fuel chamber tube.

20. A fuel pump, comprising:

a case, including:

a first section comprising a hub and a hole;

a second section concentrically arranged around the first section, wherein a radial space is arranged between the first section and the second section;

an inlet in fluid communication with the radial space;

a housing chamber arranged adjacent to the first section and the second section;

and,

an outlet in fluid communication with the hole;

a filter removably connected to the hub;

a filter bowl removably connected to the second section and operatively arranged to secure the filter to the case, the filter bowl fluidly connecting the radial space with the hole;

a valve assembly arranged at least partially in the first section and at least partially in the housing chamber, the valve assembly including:

a fuel chamber tube comprising a first end and a second end;

a check valve assembly arranged in the fuel chamber tube at the first end; and,

a plunger assembly slidingly arranged in the fuel chamber tube at the second end;

and,

a solenoid coil concentrically arranged around the plunger assembly, the solenoid coil operatively arranged to produce a magnetic field to displace the plunger assembly in a first axial direction such that fluid is selectively displaced from the inlet to the outlet.

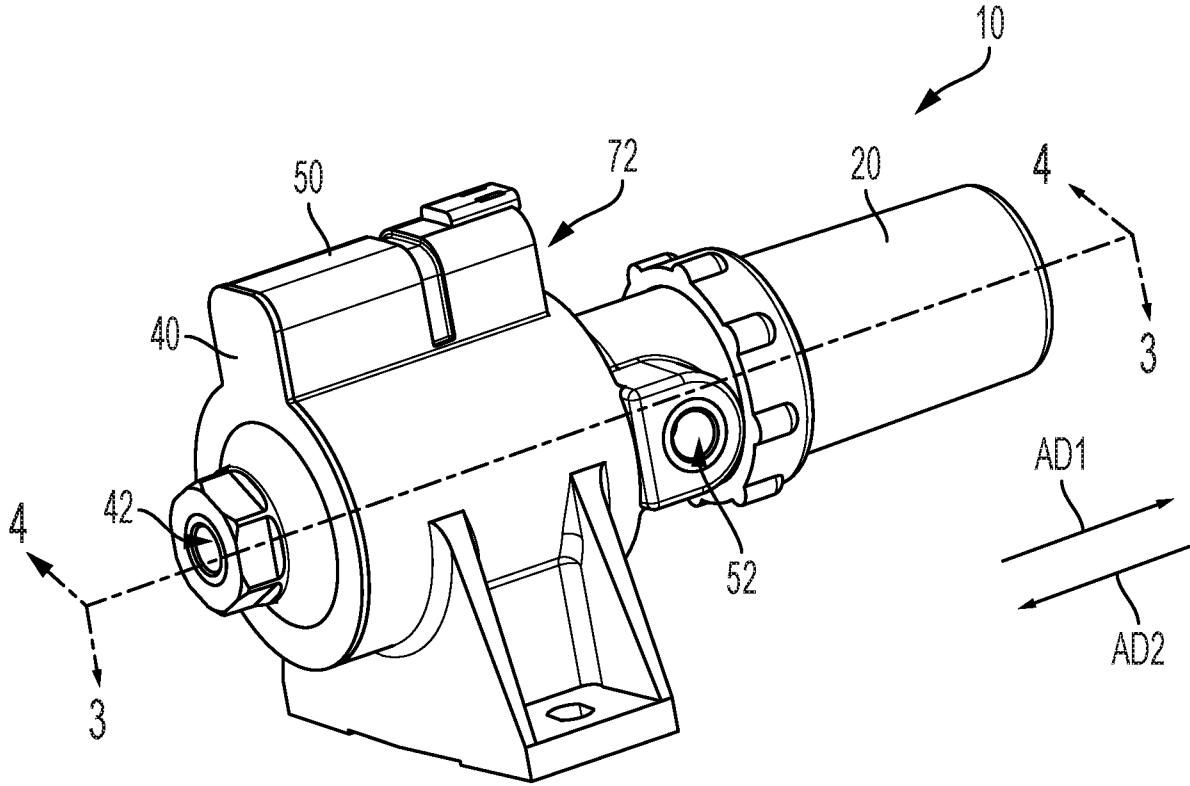

FIG. 1A

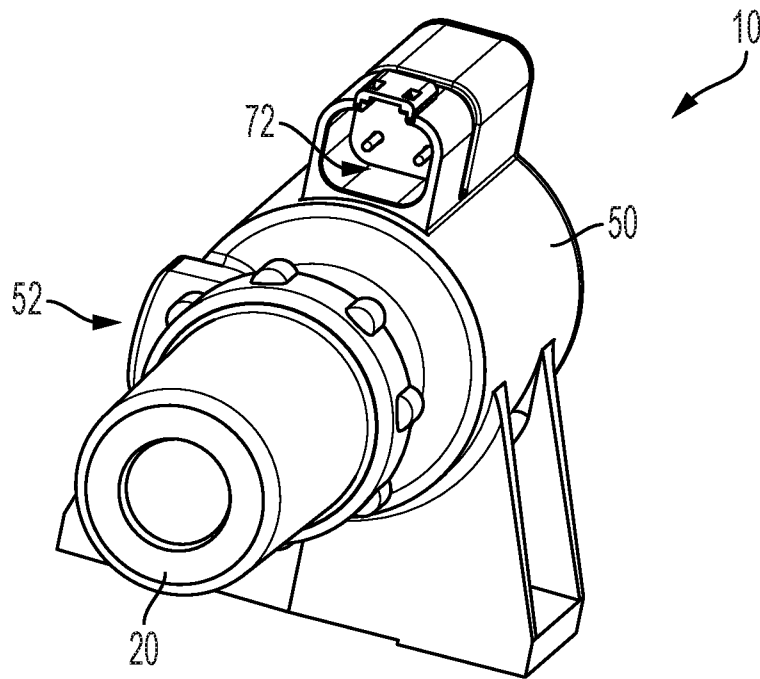

FIG. 1B

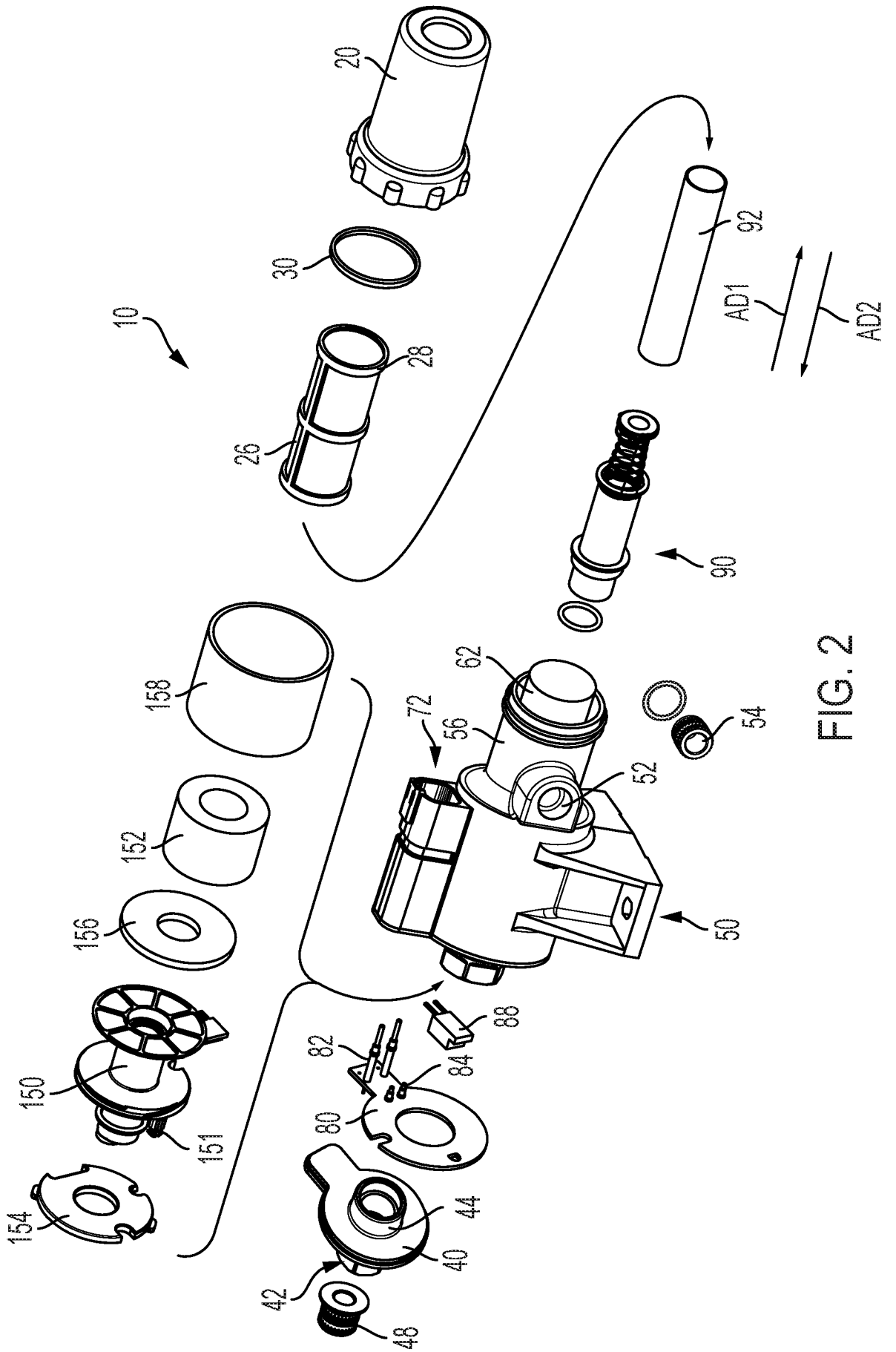

FIG. 2



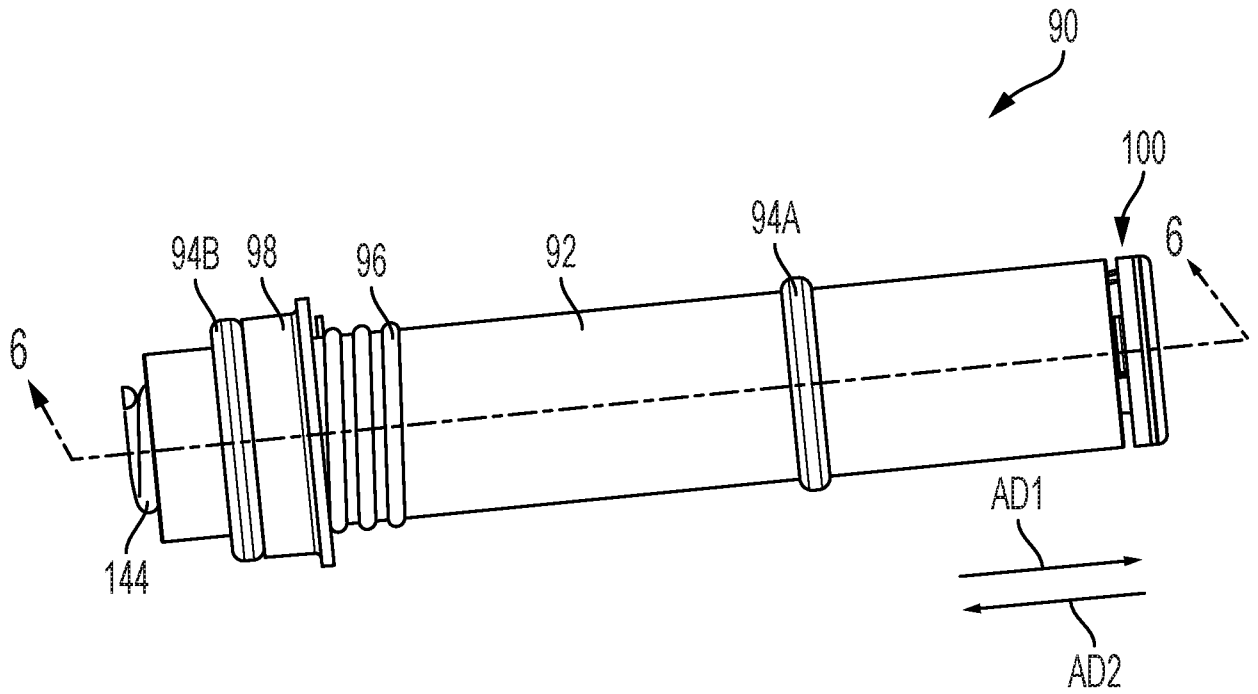

FIG. 5

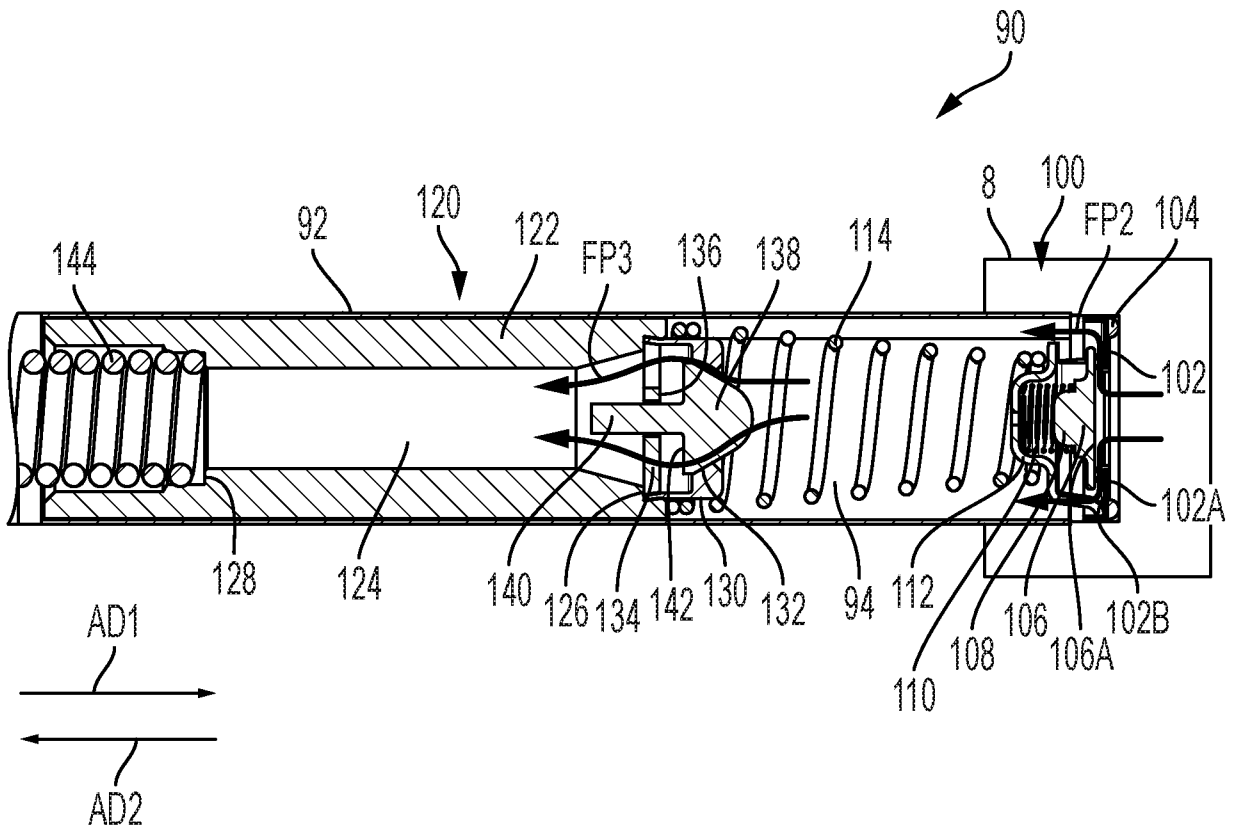

FIG. 6

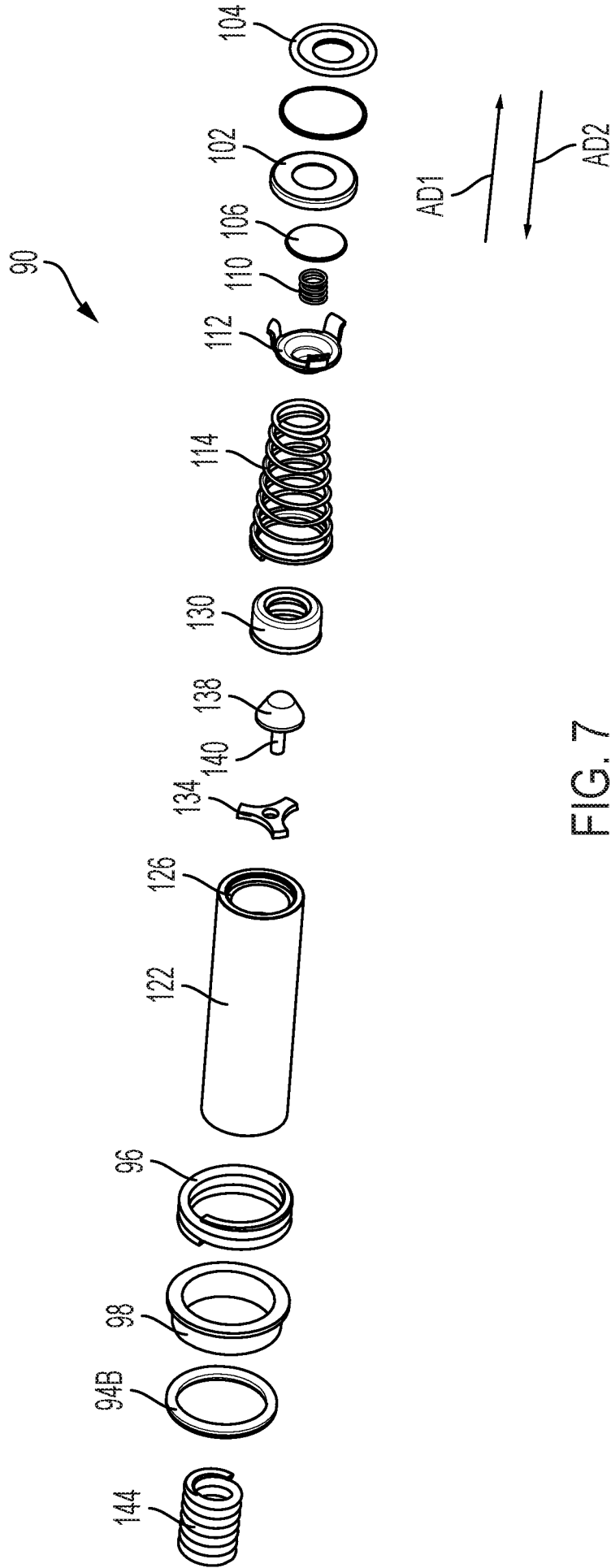

FIG. 7

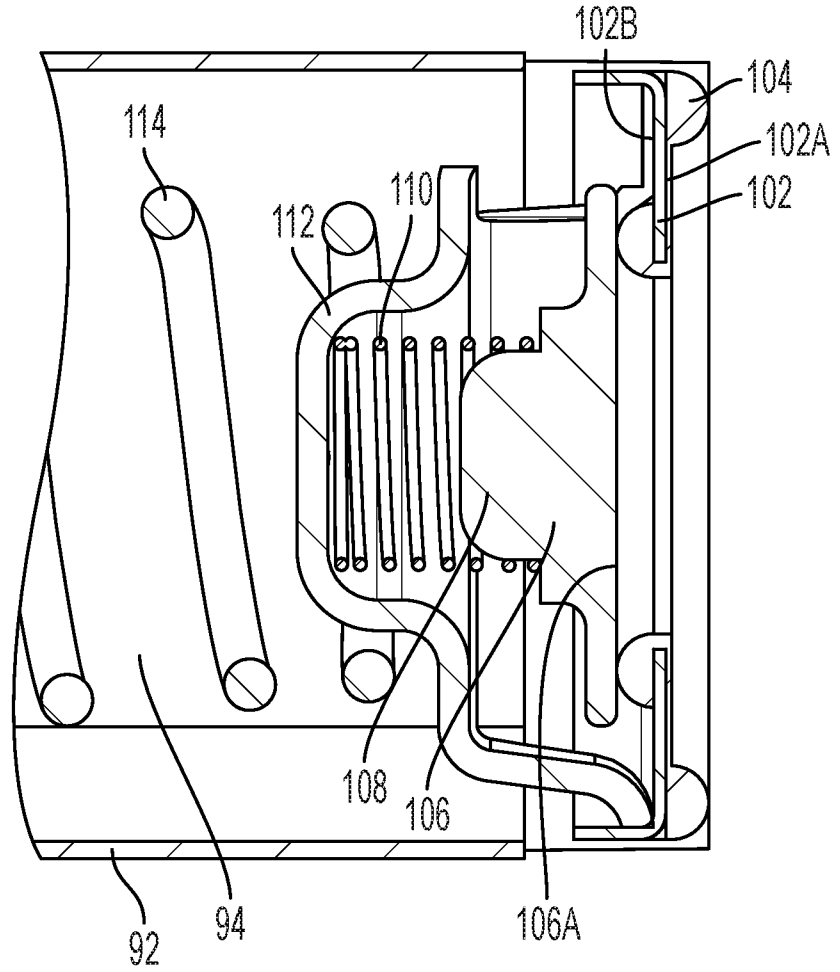

FIG. 8

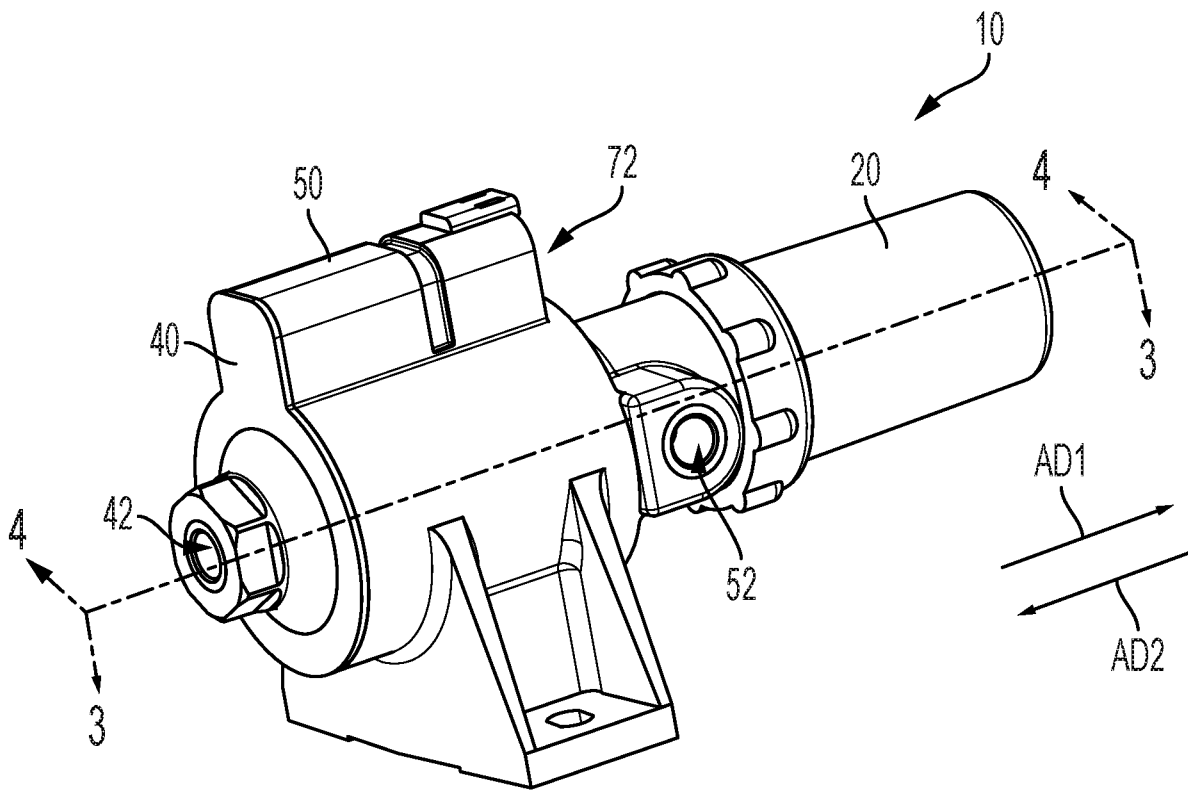

FIG. 1A