

(Model.)

3 Sheets—Sheet 1.

T. SHAW.

Machine for Registering Measurements upon Fabrics.

No. 235,968.

Patented Dec. 28, 1880.

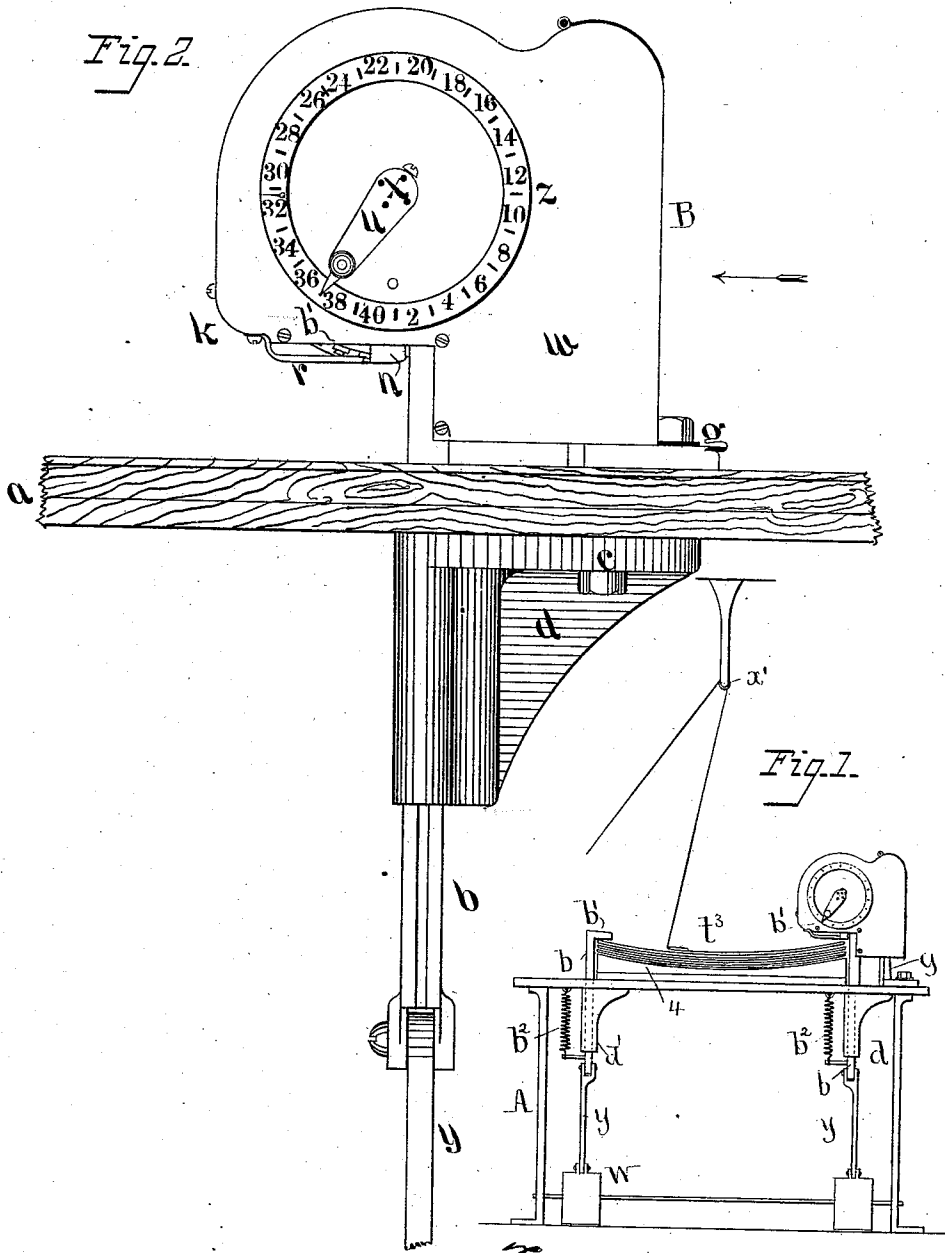

WITNESSES:

Wm Garwood
Wm B Hughes

T Shaw INVENTOR

ATTORNEY

(Model.)

3 Sheets—Sheet 2.

T. SHAW.

Machine for Registering Measurements upon Fabrics.

No. 235,968.

Patented Dec. 28, 1880.

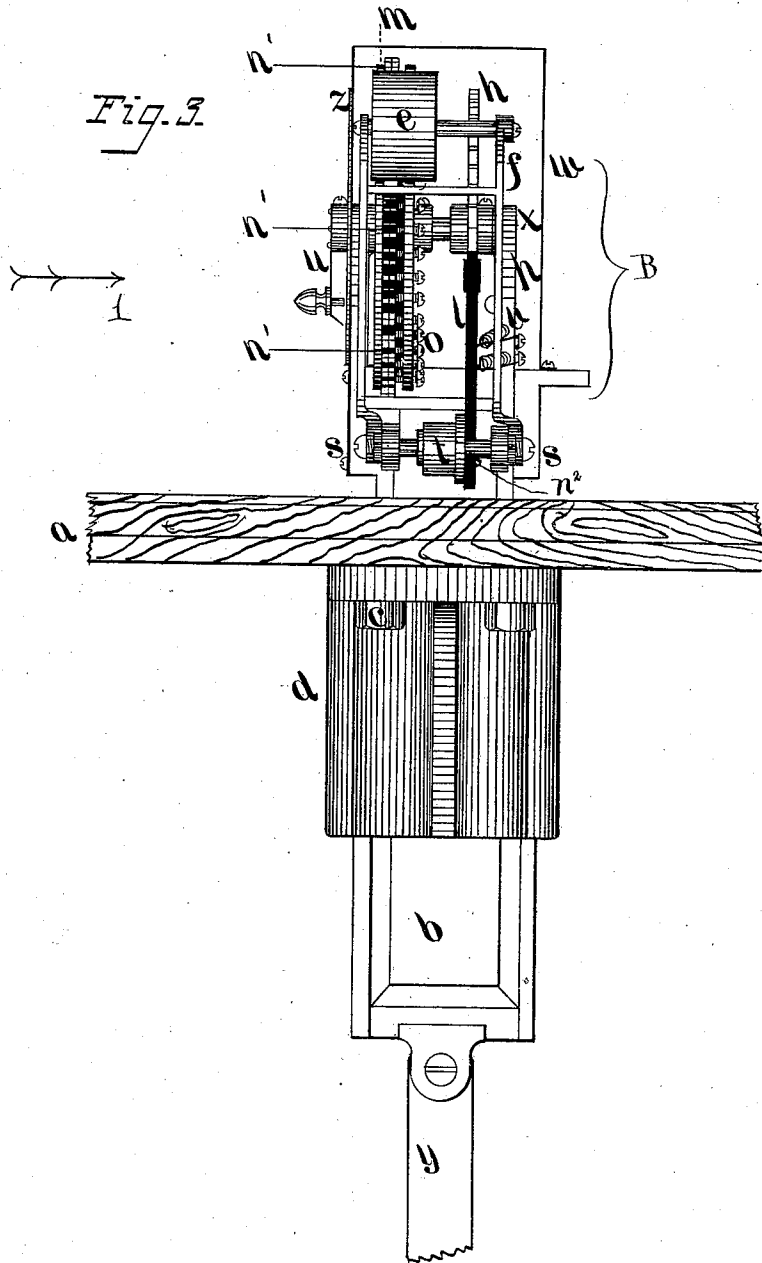

WITNESSES:

Wm Garwood
Wm B. Hughes

T. Shaw INVENTOR

ATTORNEY

(Model.)

3 Sheets—Sheet 3.

T. SHAW.

Machine for Registering Measurements upon Fabrics.

No. 235,968.

Patented Dec. 28, 1880.

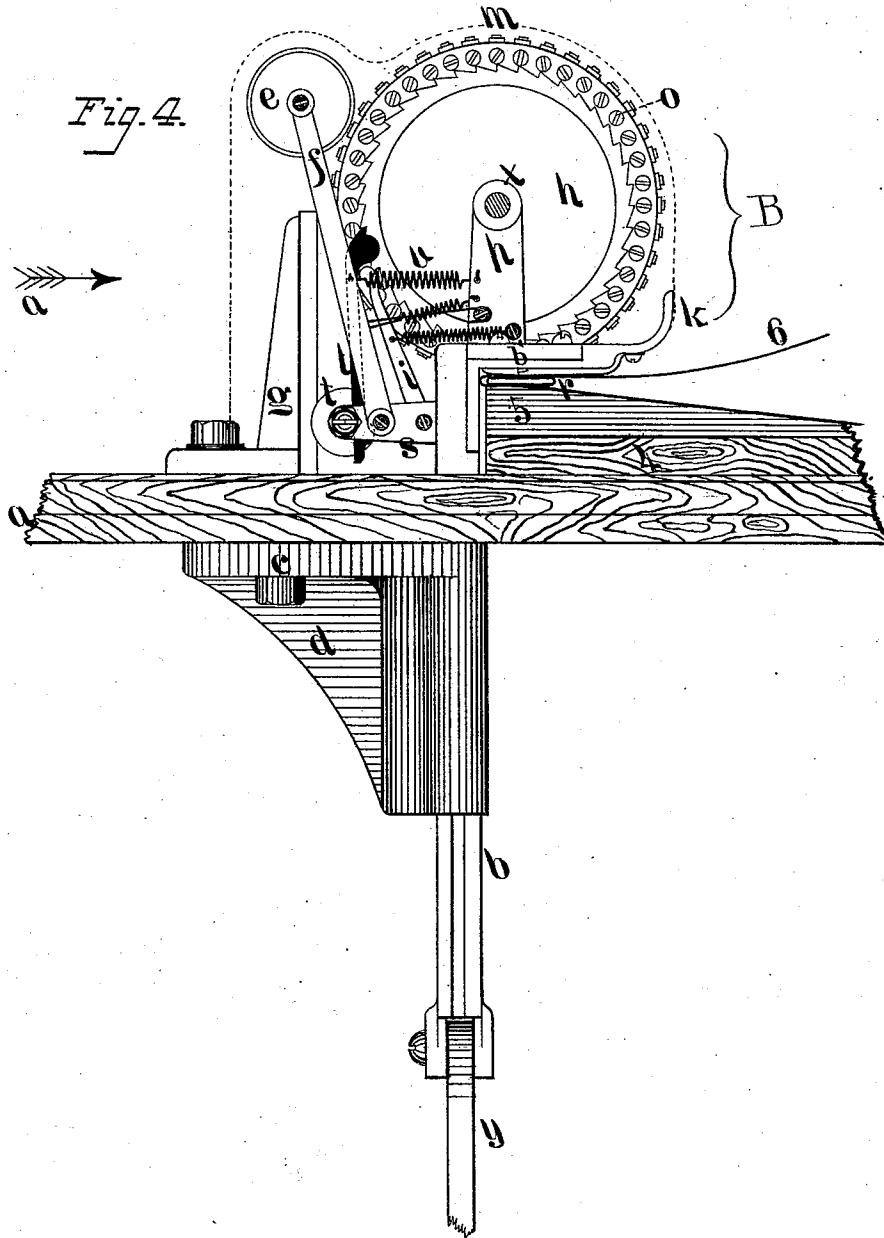

WITNESSES:

Wm. Garwood
H. B. Hughes

T. Shaw

INVENTOR

ATTORNEY

UNITED STATES PATENT OFFICE.

THOMAS SHAW, OF PHILADELPHIA, PENNSYLVANIA.

MACHINE FOR REGISTERING MEASUREMENTS UPON FABRICS.

SPECIFICATION forming part of Letters Patent No. 235,968, dated December 28, 1880.

Application filed July 9, 1880. (Model.)

To all whom it may concern :

Be it known that I, THOMAS SHAW, of the city and county of Philadelphia, Pennsylvania, have invented a new and Improved Registering Attachment Applicable to Folding-Machines for Laces and other Fabrics; and I hereby declare the following to be a full, clear, and exact description of the same, reference being had to the accompanying drawings, and to the letters of reference marked thereon.

The object of my invention is a machine, constructed as fully described hereinafter, whereby I am enabled to fold with facility in long folds or layers laces and other fabrics, retain the folds in close contact with each other, and at the same time register the number of folds and stamp any required number or mark upon the material.

In the drawings forming part of this specification, Figure 1 is a side elevation of a table upon which my improved machine is mounted. Fig. 2 is a side view of the indicating device; Fig. 3, an edge view of the indicating device with the cover removed, looking in the direction of the arrow, Fig. 2. Fig. 4 is a side view of the parts shown in Fig. 3, looking in the direction of the arrow 1.

The machine consists, essentially, of a table, A, clamps B B, and a registering and printing device. At the top of table A is a curved bed, 4, covered with rubber 5, and opposite the ends of this bed, in brackets $d d'$, slide clamp-bars b , each having at the upper end a lug, b' , or its equivalent, that overhangs the end of the bed. Each clamp-bar is connected by a rod, y , to a treadle, W, conveniently arranged beneath the table to permit both treadles to be operated by the feet of the same operator, springs b^2 tending to elevate the clamp-bars.

The material to be folded is drawn toward the bed over an elevated guide-bar, x' . One end is laid upon one end of the bed, and is clamped between the latter and the lug b' of the adjacent clamp, which is depressed by means of its treadle. The operator then passes a thin blade, t^3 , over the material, so as to press it flat upon the table and carry it in a folded condition between the projecting portion b' and the opposite end of the bed, where it is clamped by depressing the clamp-bar, as

shown in Fig. 4, the blade t^3 being withdrawn and carried toward the opposite clamp-bar, which is again brought down to secure another fold. By this means the material is quickly and accurately folded, the folds being of the exact length of the distance between the faces of the clamp-bars. A knowledge of this length and of the number of folds upon the bed will permit the length of material folded to be readily ascertained; but to avoid the necessity of making a calculation I combine with the clamp a dial, z , an index-finger, u , and any suitable mechanism, whereby the index-finger is moved one point at each movement of the clamp, thereby registering the number of movements, and consequently the length of material on the bed.

While I do not limit myself to any precise form of registering mechanism, that shown in the drawings has been found very effective, and will be now described.

Between standards p on the clamp b turns a ratchet-wheel, h , to the teeth of which is adapted a pawl, l , hung to a pin, n^2 , at one side of a roller, t , the shaft of which is carried by brackets s projecting laterally from the clamp. A spring tends to keep the pawl in contact with the ratchet, and another spring-pawl, i , bearing against the ratchet, prevents back motion. The roller t is covered with rubber and bears frictionally against a fixed standard, g , whereby at each upward movement of the clamp the roller is turned, the pawl l elevated, and the ratchet-wheel moved one tooth. On descending the roller turns until the pawl strikes the roller-shaft. Thus a positive limited movement of the pawl is secured on a very slight movement of the clamp, but without interfering with a more extended motion, during which the roller will slide without rotating over the standard.

The index-finger u is secured to the shaft x , and is provided with a handle, whereby it may be brought back to zero after each quantity of cloth has been measured.

In connection with the registering device, which may be covered by a case, w , I may use a printing device consisting of a type-wheel, m , carrying type n , secured by screws o , and an absorbent inking-roller, e , carried by arms f , hung to the arm s and held by a spring

against the type. The type-wheel is mounted upon and carried with the shaft *x*, so as to bring the types successively above the folds of cloth or other material, printing a new number, figure, or character at each fold. To press the fold firmly before the type is applied, I secure a spring-plate, *r*, beneath the shoulder *b'* of the clamp, which plate bears upon the fold, so as to press the latter closely before the type is brought upon the same.

I claim—

1. In a folding device, the bed 4 and vertical sliding clamps *b b'*, combined with treadles and springs, whereby said clamps may be independently operated at the will of the operator, substantially as set forth.

2. The combination, with the clamp *b* and standard *g*, of a shaft, *x*, carrying an index-finger and ratchet, and a roller, *t*, carrying a pawl and bearing against the standard, substantially as set forth.

3. The combination, with the bed and clamp of a measuring-machine, of a type-wheel arranged to bear upon the folds of material and mechanism for rotating the wheel, substantially as set forth.

THOMAS SHAW.

Witnesses:

WM. GARWOOD,
WM. B. HUGHES.