



US012252827B2

(12) **United States Patent**  
**Magnusson**

(10) **Patent No.:** **US 12,252,827 B2**

(45) **Date of Patent:** **Mar. 18, 2025**

- (54) **LAUNDRY WASHING MACHINE**
- (71) Applicant: **Roderinno AB**, Nacka Strand (SE)
- (72) Inventor: **Fredrik Magnusson**, Saltsjö-boo (SE)
- (73) Assignee: **Roderinno AB**, Nacka Strand (SE)
- (\* ) Notice: Subject to any disclaimer, the term of this patent is extended or adjusted under 35 U.S.C. 154(b) by 164 days.

- (58) **Field of Classification Search**  
CPC ..... D06F 15/02; D06F 21/00; D06F 21/04; D06F 39/08; D06F 47/06  
See application file for complete search history.

- (56) **References Cited**  
U.S. PATENT DOCUMENTS  
1,949,278 A 2/1934 Johnson  
2,692,494 A \* 10/1954 Candor ..... D06F 13/00 68/21

- (21) Appl. No.: **17/795,404**
- (22) PCT Filed: **Jan. 30, 2021**
- (86) PCT No.: **PCT/EP2021/052222**  
§ 371 (c)(1),  
(2) Date: **Jul. 26, 2022**
- (87) PCT Pub. No.: **WO2021/152158**  
PCT Pub. Date: **Aug. 5, 2021**

- FOREIGN PATENT DOCUMENTS  
CH 226437 A 4/1943  
CN 204530216 U 8/2015  
(Continued)

- (65) **Prior Publication Data**  
US 2023/0054491 A1 Feb. 23, 2023

- OTHER PUBLICATIONS  
Written Opinion and International Search Report corresponding to Application No. PCT/EP2021/052222 mailed Apr. 1, 2021.  
(Continued)

- (30) **Foreign Application Priority Data**  
Jan. 31, 2020 (SE) ..... 2050104-5

*Primary Examiner* — Joseph L. Perrin  
(74) *Attorney, Agent, or Firm* — Renner, Otto, Boisselle & Sklar, LLP

- (51) **Int. Cl.**  
**D06F 21/04** (2006.01)  
**D06F 21/00** (2006.01)  
(Continued)

- (57) **ABSTRACT**  
A laundry washing machine contains a rotatable drum (210) configured to hold laundry (240) during washing thereof. The rotatable drum (210), in turn, contains at least one flexible body (215) configured to alter its volume in response to a fluid medium (F) being fed into or extracted out from an interior of the at least one flexible body (215). As a result, the at least one flexible body (215) varies a volume available for washing fluids (W) and the laundry (240) in the rotatable drum (210), so that for example gentle and yet highly efficient kneading washing actions can be performed.

- (52) **U.S. Cl.**  
CPC ..... **D06F 21/04** (2013.01); **D06F 21/00** (2013.01); **D06F 39/08** (2013.01); **D06F 47/06** (2013.01); **D06F 15/02** (2013.01)

**12 Claims, 7 Drawing Sheets**

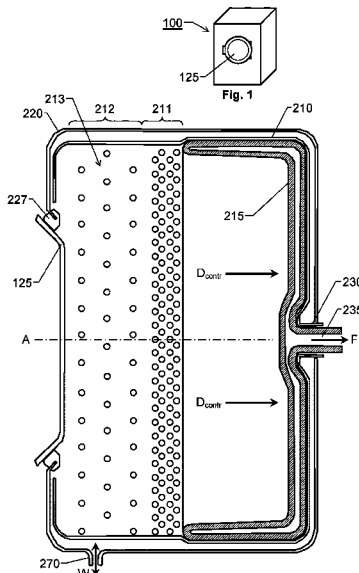

- (51) **Int. Cl.** 4,763,495 A \* 8/1988 Hayashi ..... B30B 9/22  
*D06F 39/08* (2006.01) 100/211  
*D06F 47/06* (2006.01) 2016/0258097 A1 9/2016 Hake et al.  
*D06F 15/02* (2006.01)

FOREIGN PATENT DOCUMENTS

- (56) **References Cited**

U.S. PATENT DOCUMENTS

- 2,712,229 A \* 7/1955 Jones ..... D06F 47/06  
 68/21  
 2,737,039 A \* 3/1956 Wales ..... B30B 9/22  
 68/21  
 2,743,599 A \* 5/1956 Bilde ..... D06F 47/06  
 68/12.14  
 2,749,735 A 6/1956 Candor  
 2,759,348 A \* 8/1956 Gibson ..... D06F 29/02  
 68/21  
 2,817,228 A \* 12/1957 Koplín ..... D06F 47/06  
 68/242  
 2,824,438 A \* 2/1958 Candor ..... D06F 47/06  
 100/211

- CN 206279353 U 6/2017  
 CN 107217441 A 9/2017  
 CN 110409103 A 11/2019  
 DE 1485006 A1 5/1969  
 WO 2018222125 A1 12/2018  
 WO 2019004896 A1 1/2019

OTHER PUBLICATIONS

Swedish Search Report corresponding to Swedish Application No. 2050104-5 mailed on Sep. 7, 2020.  
 Communication pursuant to Article 94(3) EPC for corresponding European Application No. 21 702 968.5 dated Sep. 9, 2024.

\* cited by examiner

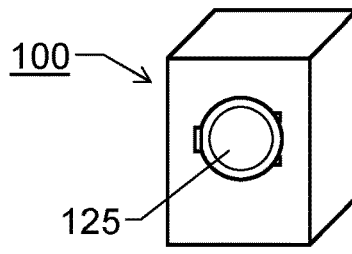

Fig. 1

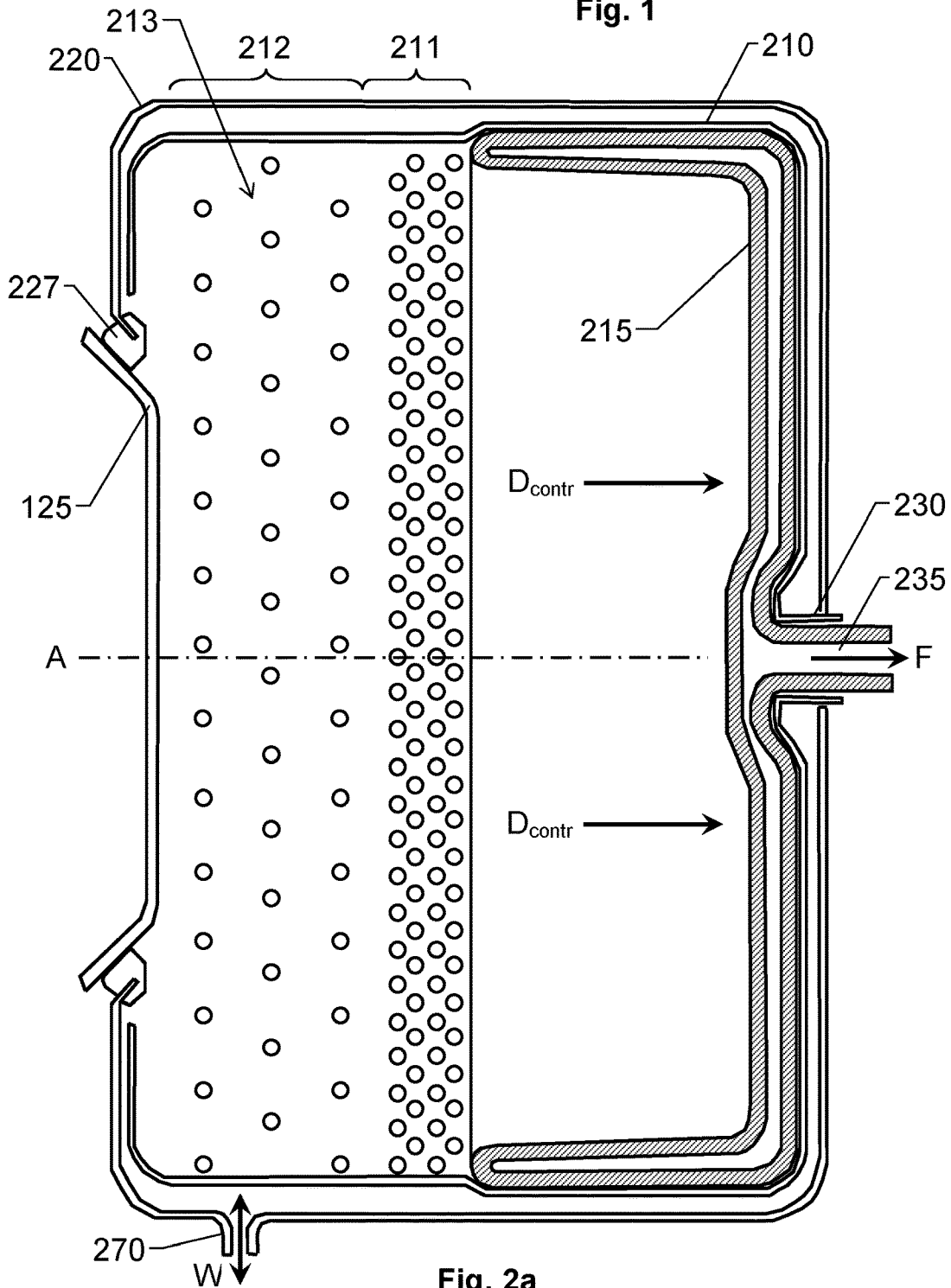

Fig. 2a

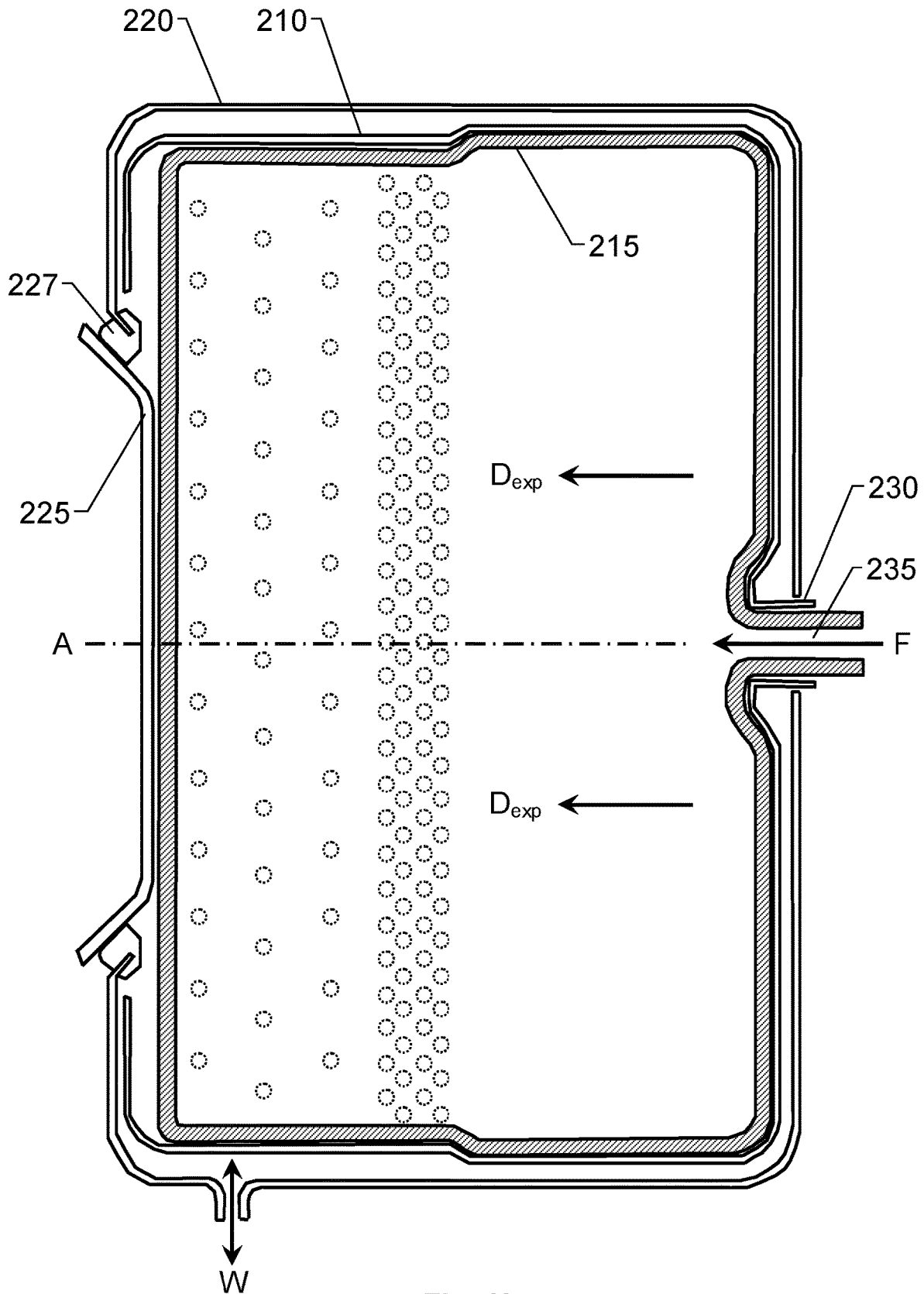

Fig. 2b

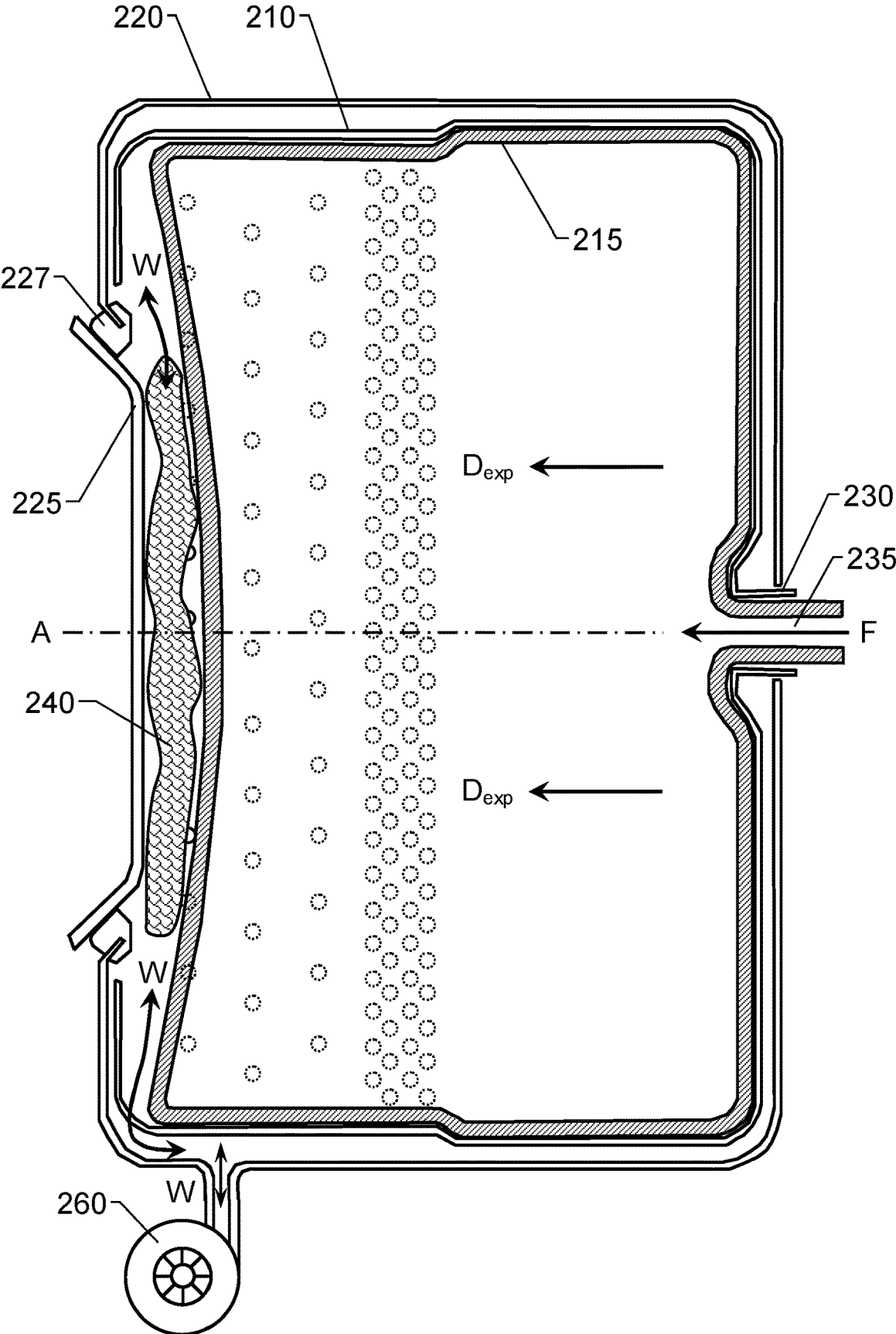

Fig. 2c

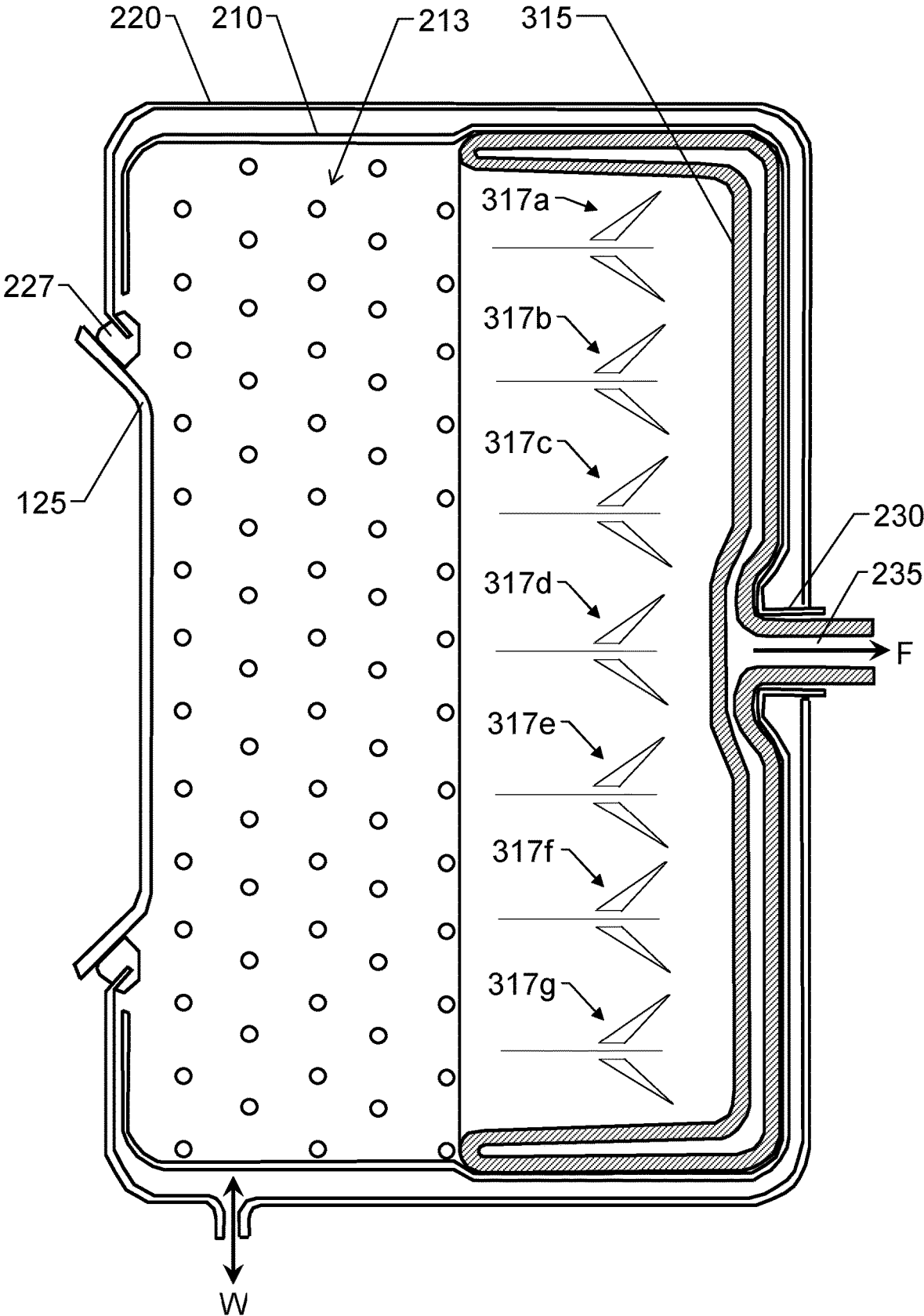

Fig. 3

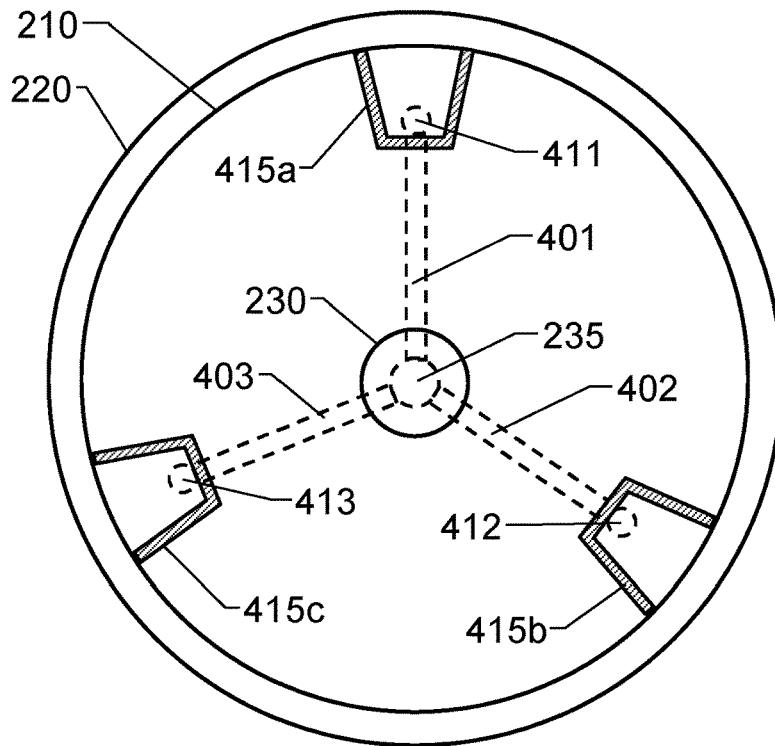

Fig. 4a

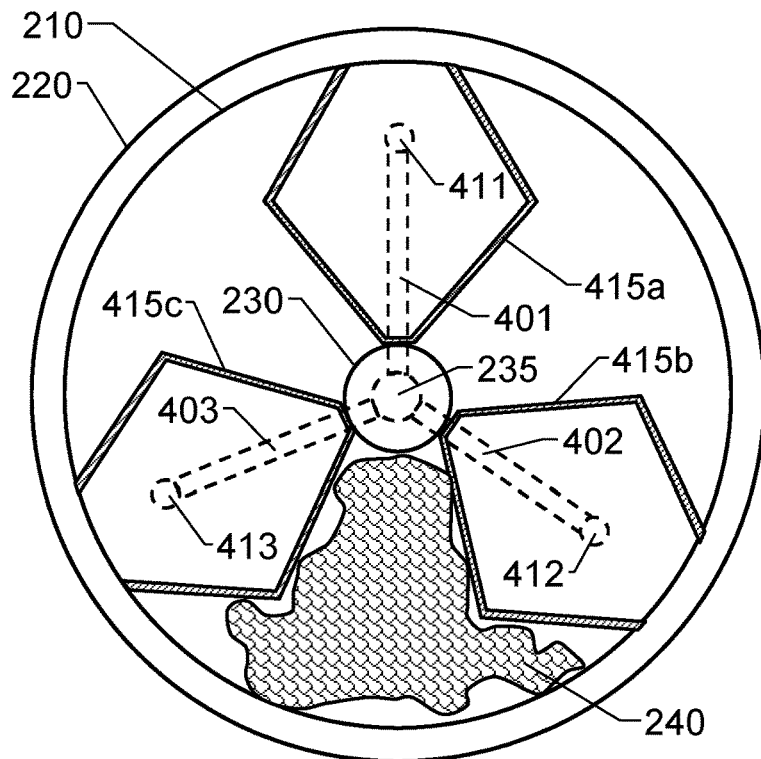

Fig. 4b

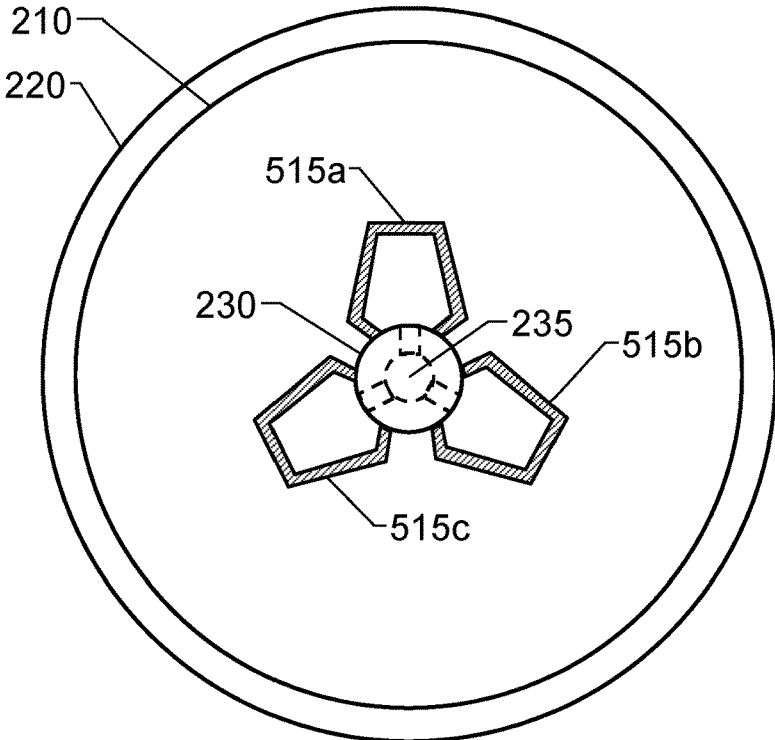

Fig. 5a

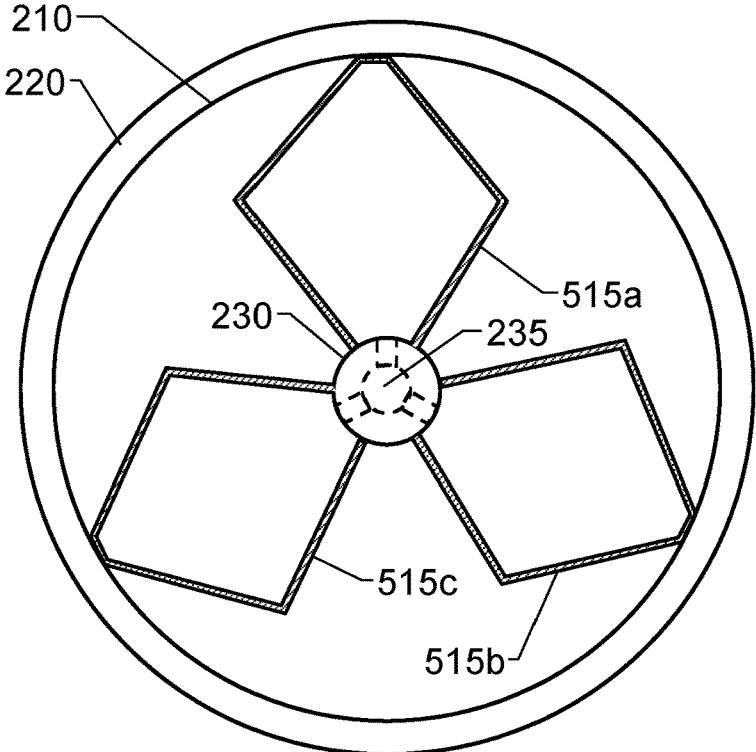

Fig. 5b

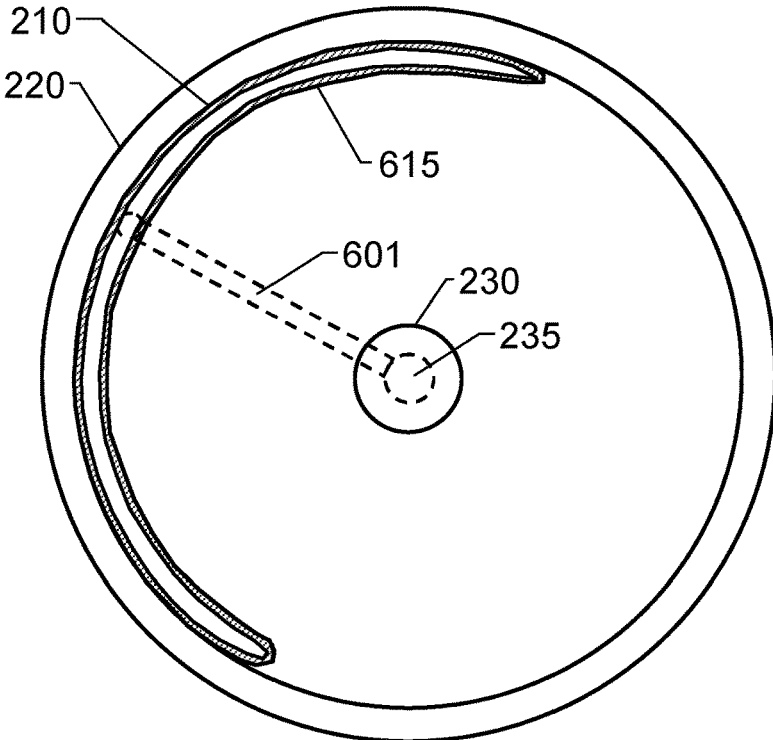

Fig. 6a

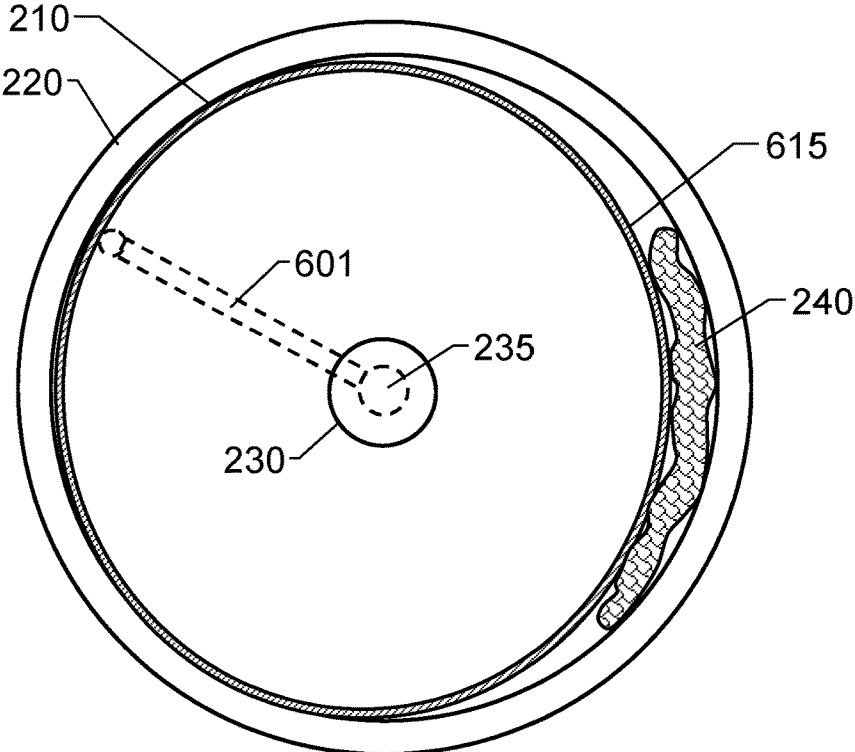

Fig. 6b

1

**LAUNDRY WASHING MACHINE**

This application is a national phase of International Application No. PCT/EP2021/052222 filed Jan. 30, 2021, which claims priority to Swedish Application No. 2050104-5 filed Jan. 31, 2020, each of which is hereby incorporated herein by reference in its entirety.

**TECHNICAL FIELD**

The invention relates generally to automatic washing of laundry. In particular, the present invention concerns a laundry washing machine for washing clothes and other textile items, the dirtiness of which may vary over a very broad range.

**BACKGROUND**

Today, numerous types of laundry washing machines are known that are highly efficient in terms of mechanically removing dirt particles and similar undesired fragments from clothes. Virtually every one of these machines operate according to a principle where a cylindrical drum rotates and thus causes pieces of laundry to tumble and be tossed around together with detergents. The cylindrical drum may either be arranged with its rotation axis oriented horizontally or vertically. This, of course, affects how gravity interacts with the movements of the pieces of laundry inside the drum. In general, however, the washing functionality is the same in both cases, namely mechanical action in the form of turning, shaking and rubbing fabric surfaces against one other and against the walls of the drum until the dirt particles have been removed, and can subsequently be conveyed out from the drum via openings in the drum wall.

Such mechanical treatment typically accomplishes good washing results, especially if the laundry is relatively dirty. However, these results come at a price, for example in terms of high water consumption, severe wear on the clothing and water pollution due to microfibers being torn away in the washing process. The drum-based laundry washing machines are also fairly noisy and cause vibrations.

Therefore, in recent years, alternative types of washing machines have been presented. For instance, WO 2018/222125 describes a washing machine that has a main part and a flexible washing compartment in which the washing of the laundry takes place. The flexible washing compartment has a sealable opening for receiving the laundry to be washed. The washing machine further has an inlet for supplying washing water into the flexible washing compartment and an outlet for disposal of washing water from the flexible washing compartment. A mechanical pressure device is arranged at the flexible washing compartment to provide mechanical lifting pressure on the outside of a part of the flexible washing compartment, such that the laundry is subjected to mechanical action to assist washing.

WO 2019/004896 shows a washing machine that includes one or more flexible washing compartments that each contains a particular washing zone, in which a flow of washing water typically containing detergents and/or stain removers, is arranged to oscillate through a stacked layer of laundry. Consequently, progressive washing is obtained essentially of the whole content of the stacked laundry.

The latter two solutions above tackle the problems of high water consumption, severe wear on the clothing and micro-fiber related water pollution. However, at least in some cases when the laundry is very dirty, these solutions may be

2

inferior to the drum-based mechanical laundry washing machines with respect to cleaning efficiency.

**SUMMARY**

It is therefore an object of the present invention to offer an automatic laundry washing solution that attains a good cleaning result regardless of how dirty the laundry is, and at the same time, avoids unnecessary use of water, minimizes the amount of microfibers being emitted into the sewage as well as prevents excessive wear on the clothes.

According to the invention, this object is achieved by a laundry washing machine containing a rotatable drum configured to hold laundry during washing thereof. The rotatable drum includes at least one flexible body configured to alter its volume in response to a fluid medium being fed into or extracted out from an interior of the at least one flexible body. As a result, a volume available for washing fluids and the laundry in the rotatable drum varies.

This laundry washing machine is advantageous because it can operate according to a very broad range of washing programs including everything from extremely mild programs, where cleaning fluids are gently driven through stationary pieces of laundry to intense programs involving highly agitating washing actions, where for example the laundry is subjected to quick movements and high temperatures. Thus, a tailored washing program can be employed for each degree of laundry dirtiness.

Furthermore, the proposed combination of the rotatable drum and the at least one flexible body enables entirely new washing actions, such as wherein pieces of laundry are turned and kneaded repeatedly in an alternating process. Thereby, washing liquids can be systematically passed through different combinations of layers of fabric, which accomplishes a very efficient cleaning. Since such a process means that the laundry is pressed in more angles than in conventional laundry machines, this also leads to less wrinkles and creases in the cleaned laundry.

According to one embodiment of the invention, the laundry washing machine contains a rotating shaft that drives the rotatable drum. The rotating shaft has a passage configured to feed the fluid medium into and extract the fluid medium out from the at least one flexible body. Thus, the at least one flexible body can be controlled to alter its shape and volume in an efficient and convenient manner via pump mechanisms outside the rotatable drum also during rotation thereof.

According to another embodiment of the invention, at least one of the at least one flexible body is non-axially arranged relative to the rotating shaft in the rotatable drum. This design is advantageous inter alia because it enables agitators of different shapes and sizes to be formed in the rotatable drum. Depending on the size and shape of the agitators, the agitators can assist in causing the laundry to be tossed and tumbled in various ways in the rotatable drum.

According to one embodiment of the invention, the at least one flexible body is configured to receive the fluid medium so as to expand its/their volume to create at least one delimited space for washing fluids and the laundry inside the rotatable drum. This is suitable for washing of few or smaller pieces of laundry since it requires less water.

According to yet another embodiment of the invention, the at least one flexible body is configured to receive the fluid medium so as to expand its/their volume until the laundry is at least temporarily fixated against an inside surface of the rotatable drum. Consequently, pieces of laundry can be held stationary during an entire washing program. As an alternative, or in addition thereto, according

3

to one embodiment of the invention, the rotatable drum is configured to execute washing actions involving rotation of the rotatable drum while the at least one flexible body causes the laundry to be kneaded against an inside surface of the rotatable drum by pulsating the fluid medium to be fed into and out from the interior of the at least one flexible body. This results in repeated expansion and contraction of the at least one flexible body. Thereby, the laundry can be kneaded and rubbed while washing liquids are passed there through, thus providing efficient washing of delicate clothing that is severely soiled.

According to still another embodiment of the invention, the at least one flexible body contains one central flexible body that is arranged symmetrically around the rotating shaft in the rotatable drum. The central flexible body is configured to expand in an expansion direction away from the fluid-medium passage. The expansion direction is here parallel, or at least essentially parallel, to a symmetry axis of the rotatable drum. This accomplishes a reduced drum volume between the central flexible body and the drum door, which is suitable for washing small amounts of laundry with efficient use of water. Alternatively, or additionally, the laundry may be kneaded/rubbed against a rigid surface, e.g. the drum door, as described above by repeated expansion and contraction of the central flexible body.

Preferably, the rotatable drum contains a set of openings configured to allow the washing fluids to be discharged into a receiving chamber surrounding the rotatable drum. According to one embodiment of the invention, the set of openings include first and second zones; where, in the first zone, a ratio between a total opening area and a total non-opening area is higher than the ratio between the total opening area and the total non-opening area in the second zone. The first zone is located closer to the fluid-medium passage than the second zone. Hence, also if the at least one flexible body has been expanded so that the washing volume is reduced, the washing liquids can exit efficiently from the rotatable drum.

When the central flexible body has been expanded to less than a maximal volume, an exterior side surface of the central flexible body is exposed to the washing fluids. According to one embodiment of the invention, the exterior side surface contains at least one fluid conveying pattern, which is configured to transport the washing fluids from the exterior side surface towards the set of openings the rotatable drum. This further improves the emission of washing liquids from the rotatable drum in emptying phases of a washing program.

According to yet another embodiment of the invention, the rotatable drum is configured to execute washing actions involving rotation of the rotatable drum intended to cause the laundry therein to tumble. As a result, conventional drum-based laundry washing can be effected.

Further, according to one embodiment of the invention, the laundry washing machine contains at least one pressure generator configured to force the washing liquids to pass through the laundry while the at least one flexible body causes the laundry to be fixated, at least temporarily, against an inside surface of the rotatable drum. Here, the fluid medium is pulsated to be fed into and out from the interior of the at least one flexible body while the rotatable drum is stationary, at least temporarily. This typically accomplishes good a washing result if the laundry is mildly dirty. In other situations, it may be more efficient to control the at least one pressure generator to force the washing liquids to pass through the laundry while the at least one flexible body

4

causes the laundry to be kneaded against an inside surface of the rotatable drum while the rotatable drum either rotates or is held stationary.

Further advantages, beneficial features and applications of the present invention will be apparent from the following description and the dependent claims.

#### BRIEF DESCRIPTION OF THE DRAWINGS

The invention is now to be explained more closely by means of preferred embodiments, which are disclosed as examples, and with reference to the attached drawings.

FIG. 1 shows a highly schematic perspective view of a laundry washing machine according to one embodiment of the invention;

FIGS. 2a-c show cross-section views of a rotatable drum and a receiving chamber according to a first embodiment of the invention;

FIG. 3 shows a cross-section view of the rotatable drum and the receiving chamber according to a second embodiment of the invention;

FIGS. 4a-b show front views of the rotatable drum and the receiving chamber according to a third embodiment of the invention;

FIGS. 5a-b show front views of the rotatable drum and the receiving chamber according to a fourth embodiment of the invention; and

FIGS. 6a-b show front views of the rotatable drum and the receiving chamber according to a fifth embodiment of the invention.

#### DETAILED DESCRIPTION

FIG. 1 shows a highly schematic perspective view of a laundry washing machine **100** according to one embodiment of the invention. The laundry washing machine **100** has a drum door **125** that provides access to a rotatable drum **210** for holding laundry to be washed.

FIG. 2a shows cross-section view of the rotatable drum **210** and a surrounding receiving chamber **220** according to a first embodiment of the invention. The rotatable drum **210** contains at least one flexible body, which here is exemplified by a central flexible body **215** configured to alter its volume in response to a fluid medium F being fed into or extracted out from an interior of the central flexible body **215**. As a result, a volume available for washing fluids W and the laundry **240** in the rotatable drum **210** varies. The fluid medium F may be represented by any type of gas, preferably air, and/or any type of liquid, preferably water. The washing fluids W typically contain water and various types of detergents, softeners and/or rinsing substances. The drum door **125** is surrounded by a watertight seal **227** to the receiving chamber **220** so that the washing fluids W remain inside the rotatable drum **210** and the surrounding receiving chamber **220** until being emptied via a pipe **270** controlled by an associated valve (not shown), and possibly a pump (not shown).

A rotating shaft **230** drives the rotatable drum **210** inside the receiving chamber **220**. Preferably, the rotating shaft **230** includes a passage **235** that is configured to feed the fluid medium F into the central flexible body **215**, and extract the fluid medium F out there from. This arrangement is beneficial because it allows the central flexible body **215** to be controlled to alter its shape and volume in an efficient and convenient manner via a pump mechanism (not shown) outside the rotatable drum **210** regardless of whether the drum **210** rotates or is stationary.

The main purpose of the rotatable drum **210** is to execute washing actions involving rotation of the rotatable drum **210** to cause the laundry **240** therein to tumble and be rearranged.

According to embodiments of the invention, the rotatable drum **210** may also execute washing actions involving rotation of the rotatable drum **210** while the at least one flexible body therein causes the laundry **240** to be kneaded against an inside surface of the rotatable drum **210**.

In FIG. **2b**, we see a cross-section view of the rotatable drum **210** and the surrounding receiving chamber **220** according to the first embodiment of the invention when the central flexible body **215** has attained a maximal volume, i.e. has expanded all the way up against the drum door **225**. Specifically, in this embodiment, the central flexible body **215** is configured to expand in an expansion direction  $D_{exp}$  away from the passage **235**. The expansion direction  $D_{exp}$  is parallel to, or at least essentially parallel to, a symmetry axis **A** of the rotatable drum **210**. Preferably, the central flexible body **215** covers the full diameter of the rotatable drum **210** so that it fills essentially the entire volume of the rotatable drum **210** when maximally expanded. Namely, this provides a highest degree of freedom as how to vary the volume available for the washing fluids **W** and the laundry **240** in the rotatable drum **210**. Such a design of the central flexible body **215** also renders it possible to fixate pieces of laundry **240** against an inside surface of the rotatable drum **210** as illustrated in FIG. **2c**. Consequently, the laundry **240** can be held stationary either during an entire washing program, or during one or more periods thereof. It is often beneficial if the laundry washing machine **100** operates in an alternating manner, wherein, in one phase, the rotatable drum **210** is controlled to rotate a few revolutions to turn around the pieces of laundry while the central flexible body **215** is contracted, and in another phase, the central flexible body **215** is expanded to knead the pieces of laundry while the rotatable drum **210** is stationary. Thereby, the washing liquids **W** can be systematically passed through different combinations of layers of fabric in the laundry **240**. This, in turn, accomplishes a very efficient cleaning. Moreover, such a process means that the laundry **240** is pressed in a large number of angles, which leads to relatively few wrinkles and creases in the cleaned laundry **240**.

According to one embodiment of the invention, the laundry washing machine **100** contains at least one pressure generator, schematically indicated by reference number **260** in FIG. **2c**, which is configured to force the washing liquids **W** to pass through the laundry **240** while the at least one flexible body, exemplified by the central flexible body **215** in FIGS. **2a** to **2c**, causes the laundry **240** to be fixated against an inside surface of the rotatable drum **210**, for instance the drum door **225**, and the rotatable drum **210** is stationary.

In FIG. **2c**, the at least one pressure generator is symbolized by reference number **260**. In an actual implementation, the at least one pressure generator is typically represented by one or more pumps, for example a first pump configured to create a vacuum pressure for extracting the washing liquids **W** from the rotatable drum **210** by suction, and/or a second pump configured to create an overpressure for pushing the washing liquids **W** into the rotatable drum **210**. Further, it is advantageous if these pumps operate in cooperation with a pump system for handling the fluid medium **F**. For example, the first pump may be assisted by one or more flexible bodies being expanded, and the second pump may be assisted by one or more flexible bodies being contracted.

Preferably, the laundry washing machine **100** contains a reservoir tank (not shown), which is configured to temporarily store washing liquids **W** that have been forced through the laundry **240** and been emptied from the rotatable drum **210**. Thus, both water and detergents can be economized.

Moreover, alternatively, or additionally, the rotatable drum **210** may execute washing actions that involve rotating the rotatable drum **210** while the central flexible body **215** causes the laundry **240** to be kneaded against an inside surface of the rotatable drum, e.g. the drum door **225**. This kneading is effected by pulsating the fluid medium **F** so that it is repeatedly fed into and out from the interior of the central flexible body **215**. Thereby, the central flexible body **215** expands and contracts in a cyclic manner that causes the laundry **240** to be kneaded and rubbed while the washing liquids **W** are passed there through, thus providing efficient washing of delicate clothing being severely soiled. Analogous the expansion direction  $D_{exp}$ , the central flexible body **215** contracts towards the fluid-medium passage **235** in parallel with, or at least essentially in parallel with, the symmetry axis **A** of the rotatable drum **210**.

Naturally, the pressure generator **260** may also be configured to force the washing liquids **W** to pass through the laundry **240** while the central flexible body **215** causes the laundry **240** to be kneaded against an inside surface of the rotatable drum **210**, and while the rotatable drum **210** is either stationary or rotates. Generally, if the laundry **240** is severely soiled by dirt and/or particles, more rotation and kneading is necessary to attain a satisfying washing result; and if the laundry **240** contains delicate fabrics, it is advantageous to reduce such mechanical actions and instead force the washing liquids **W** through the laundry **240** in multiple passes.

For convenient discharge of the washing fluids **W** from the rotatable drum **210**, it preferably contains a set of openings **213** configured to allow the washing fluids **W** to be discharged into the receiving chamber **220** that surrounds the rotatable drum **210**.

Further preferably, the set of openings **213** contains first and second zones **211** and **212** respectively. In the first zone **211** a ratio between a total opening area and a total non-opening area is higher than the ratio between the total opening area and the total non-opening area in the second zone **212**. It is advantageous if all the openings have a relatively small diameter, for example of equal size as shown in FIG. **2a**, and the density of openings is higher in the first zone **211** than in the second zone **212**. However, alternatively, the openings may instead be larger in the first zone **211** than in the second zone **212**, and/or the shape of the openings may vary. Moreover, the set of openings **213** in the rotatable drum **210** may contain one or more zones in addition to the first and second zones of openings **211** and **212**. In any case, the first zone **211** is located closer to the fluid-medium passage **235** than the second zone **212**. This means that also if the central flexible body **215** has been expanded so that the washing volume in the rotatable drum **210** is reduced, the washing liquids **W** can exit efficiently from the rotatable drum **210**.

FIG. **3** shows a cross-section view of the rotatable drum **210** and the receiving chamber **220** according to a second embodiment of the invention. Also here, the at least one flexible body is represented by a central flexible body **315** that is arranged symmetrically around the rotating shaft **230** in the rotatable drum **210**, which central flexible body **315** is configured to expand and contract in expansion and contraction directions  $D_{exp}$  and  $D_{contr}$  respectively being parallel to the symmetry axis **A** of the rotatable drum **210**, or

at least essentially parallel to the symmetry axis A. An exterior side surface of the central flexible body 315 is exposed to the washing fluids W when the central flexible body 315 has been expanded to less than its maximal volume. The exterior side surface contains a number of fluid conveying patterns 317a, 317b, 317c, 317d, 317e, 317f and 317g configured to transport the washing fluids W from the exterior side surface towards the set of openings in the rotatable drum 210. This facilitates the emission of the washing liquids W from the rotatable drum 210 in phases of a washing program when the amount of washing liquids W is to be reduced. For further enhanced discharge efficiency, the central flexible body 315, or any multiple non-axial counterparts thereto, can be arranged with an angle to the rotatable drum 210 so that the exterior side surface leans towards the set of openings 213 in the contracted state.

FIG. 4a shows a front view of the rotatable drum 210 and the receiving chamber 220 as seen from the drum door 225 according to a third embodiment of the invention. Here, a number of flexible bodies 415a, 415b and 415c respectively are arranged non-axially relative to the rotating shaft 230 in the rotatable drum 210.

The fluid-medium passage 235 is comprised in the rotating shaft 230, so that the fluid medium F can be fed into and extracted out from flexible bodies 415a, 415b and 415c in an efficient manner regardless of whether the drum 210 rotates or is stationary. Specifically, a set of conduits 401, 402 and 403 interconnects the fluid-medium passage 235 and the flexible bodies 415a, 415b and 415c via openings 411, 412 and 413 respectively in a short side of the rotatable drum 210 located opposite to the drum door 225.

Analogous to what has been described above, the flexible bodies 415a, 415b and 415c are configured to receive the fluid medium F, so as to expand their volumes, and thus reduce the volume available for the washing fluids W and the laundry 240 in the rotatable drum 210. The flexible bodies 415a, 415b and 415c may also create delimited spaces for the washing fluids W and the laundry 240 inside the rotatable drum 210 as illustrated in FIG. 4b.

In FIG. 4b, we see the flexible bodies 415a, 415b and 415c in a respective maximally expanded states, where they connect with the rotating shaft 230 in the center of the rotatable drum 210. Consequently, the flexible bodies 415a, 415b and 415c create delimited spaces for the washing fluids W and the laundry 240 inside the rotatable drum 210. For example, here, a piece of laundry 240 is held in a such a delimited space between the flexible bodies 415b and 415c.

FIGS. 5a and 5b show front views of the rotatable drum 210 and the receiving chamber 220 as seen from the drum door 225 according to a fourth embodiment of the invention, which essentially constitutes a design being structurally opposite to the design shown in FIGS. 4a and 4b. In FIGS. 5a and 5b a number of flexible bodies 515a, 515b and 515c respectively are likewise arranged non-axially relative to the rotating shaft 230 in the rotatable drum 210. Here, however, the flexible bodies 515a, 515b and 515c are directly connected to the rotating shaft 230 and the fluid-medium passage 235 comprised therein. Hence, in this embodiment, the flexible bodies 515a, 515b and 515c are configured to receive the fluid medium F, so as to expand their volumes towards the side wall of the rotatable drum 210, and thus reduce the volume available for the washing fluids W and the laundry 240 in the rotatable drum 210.

FIGS. 6a and 6b show front views of the rotatable drum 210 and receiving chamber 220 as seen from the drum door 225 according to a fifth embodiment of the invention. Here, one flexible body 615 is arranged non-axially relative to the

rotating shaft 230 in the rotatable drum 210. Analogous to the third embodiment described above, the one flexible body 615 is connected to the fluid-medium passage 235 comprised in the rotating shaft 230 via a conduit 601. In a deflated state, as illustrated in FIG. 6a, the flexible body 615 is smoothed out along essentially half the interior side wall of the rotatable drum 210. In an maximally expanded state, as illustrated in FIG. 6b, the flexible body 615 occupies almost the entire volume inside the rotatable drum 210. As a result, depending on how much the flexible body 615 is expanded various amounts of laundry 240 can be kneaded and/or fixated against the side wall of the rotatable drum 210 when rotating or being stationary.

The term “comprises/comprising” when used in this specification is taken to specify the presence of stated features, integers, steps or components. However, the term does not preclude the presence or addition of one or more additional features, integers, steps or components or groups thereof.

The invention is not restricted to the described embodiments in the figures; however it may be varied freely within the scope of the claims.

The invention claimed is:

1. A laundry washing machine, comprising:

a rotatable drum configured to hold laundry during washing thereof, at least one flexible body disposed within the rotatable drum and configured to alter the volume of the flexible body in response to a fluid medium being fed into or extracted out from an interior of the at least one flexible body, and as a result, varying a volume available for washing fluids and the laundry in the rotatable drum, and

a rotating shaft driving the rotatable drum, which rotating shaft comprises a passage configured to feed the fluid medium into and extract the fluid medium out from the at least one flexible body,

wherein at least one of the at least one flexible body is non-axially arranged relative to the rotating shaft in the rotatable drum.

2. The laundry washing machine according to claim 1, wherein the at least one flexible body is configured to receive the fluid medium so as to expand its/their volume until the laundry is fixated against an inside surface of the rotatable drum.

3. The laundry washing machine according to claim 1, wherein the at least one flexible body comprises one central flexible body arranged symmetrically around the rotating shaft in the rotatable drum, the central flexible body being configured to expand in an expansion direction away from the passage, which expansion direction is parallel to a symmetry axis of the rotatable drum.

4. The laundry washing machine according to claim 3, wherein the rotatable drum comprises a set of openings configured to allow the washing fluids to be discharged into a receiving chamber surrounding the rotatable drum.

5. The laundry washing machine according to claim 4, wherein: the set of openings comprises first and second zones; in the first zone a ratio between a total opening area and a total non-opening area is higher than the ratio between the total opening area and the total non-opening area in the second zone; and the first zone is located closer to the passage than the second zone.

6. The laundry washing machine according to claim 4, wherein an exterior side surface of the central flexible body is exposed to the washing fluids when the central flexible body has been expanded to less than a maximal volume, the exterior side surface comprising at least one fluid conveying

pattern configured to transport the washing fluids from the exterior side surface towards the set of openings the rotatable drum.

7. The laundry washing machine according to claim 1 wherein the at least one flexible body is configured to receive the fluid medium so as to expand its/their volume to create at least one delimited space for washing fluids and the laundry inside the rotatable drum. 5

8. The laundry washing machine according to claim 1, wherein the rotatable drum is configured to execute washing actions comprising rotation of the rotatable drum to cause the laundry therein to tumble. 10

9. The laundry washing machine according to claim 1, wherein the rotatable drum is configured to execute washing actions comprising rotation of the rotatable drum while the at least one flexible body causes the laundry to be kneaded against an inside surface of the rotatable drum. 15

10. The laundry washing machine according to claim 1, comprising at least one pressure generator configured to force the washing liquids to pass through the laundry while the at least one flexible body causes the laundry to be fixated against an inside surface of the rotatable drum, and the rotatable drum is stationary. 20

11. The laundry washing machine according to claim 1, comprising at least one pressure generator configured to force the washing liquids to pass through the laundry while the at least one flexible body causes the laundry to be kneaded against an inside surface of the rotatable drum, and the rotatable drum is stationary. 25

12. The laundry washing machine according to claim 1, wherein the rotating shaft comprises a passage affixed to the at least one flexible body. 30

\* \* \* \* \*