

## INTERNATIONAL APPLICATION PUBLISHED UNDER THE PATENT COOPERATION TREATY (PCT)

<p>(51) International Patent Classification <sup>6</sup> : <b>A61M 5/145</b></p>	<p><b>A1</b></p>	<p>(11) International Publication Number: <b>WO 99/27981</b></p> <p>(43) International Publication Date: 10 June 1999 (10.06.99)</p>
<p>(21) International Application Number: PCT/IB98/01938</p> <p>(22) International Filing Date: 4 December 1998 (04.12.98)</p> <p>(30) Priority Data: 97810947.8 4 December 1997 (04.12.97) EP</p> <p>(71) Applicant: BRACCO RESEARCH S.A. [CH/CH]; 31, route de la Galaise, CH-1228 Plan-les-Ouates (CH).</p> <p>(72) Inventors: SCHNEIDER, Michel; 34, route d'Annecy, CH-1256 Troinex (CH). JAKOB, Laurent; 27, rue du Faubourg, CH-1286 Soral (CH). GOLAY, Christophe; 9, rue du Faubourg, CH-1286 Soral (CH). BROCHOT, Jean; L'Agnellu, F-74160 Feigères (FR). YAN, Feng; 12, route des Acacias, CH-1227 Carouge (CH).</p> <p>(74) Agent: SCHNEIDER, Michel; Bracco Research, 31, route de la Galaise, CH-1228 Plan-les-Ouates (CH).</p>		<p>(81) Designated States: AU, BR, CA, JP, NO, NZ, PL, European patent (AT, BE, CH, CY, DE, DK, ES, FI, FR, GB, GR, IE, IT, LU, MC, NL, PT, SE).</p> <p><b>Published</b> <i>With international search report. Before the expiration of the time limit for amending the claims and to be republished in the event of the receipt of amendments.</i></p>

(54) Title: AUTOMATIC LIQUID INJECTION SYSTEM AND METHOD

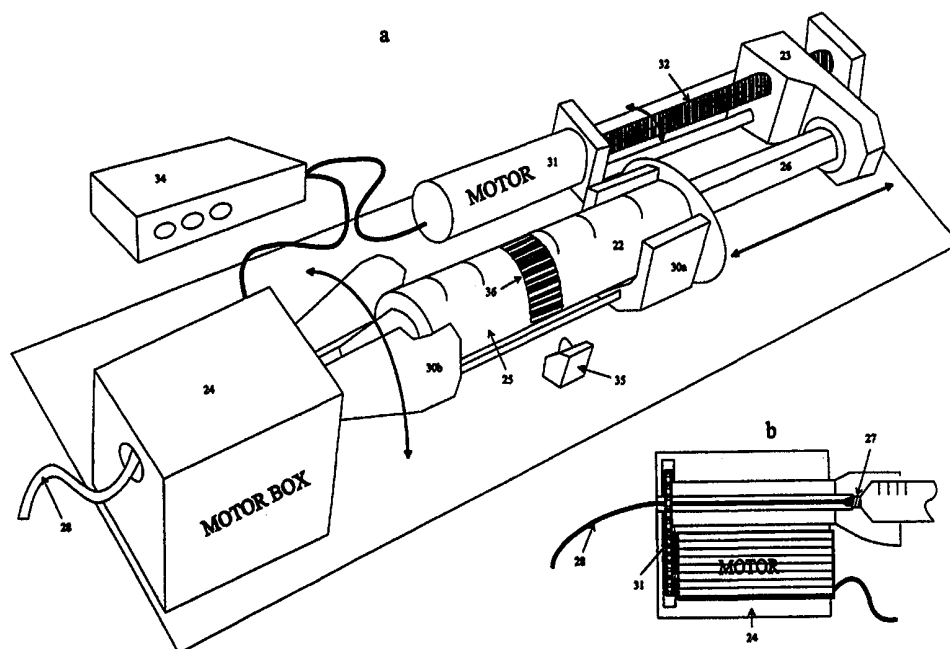

## (57) Abstract

A power assisted method and injector device for controllably delivering to patients a dispersion medicament or diagnostically active agent, the homogeneity of which is preserved throughout delivery by agitation thus preventing segregation of particles by gravity or buoyancy. Diagnostically active agents disclosed are gas microbubble suspensions useful in ultrasonic diagnostic imaging and liposomal formulations in which liposome vesicles are loaded with iodinated compounds.

**FOR THE PURPOSES OF INFORMATION ONLY**

Codes used to identify States party to the PCT on the front pages of pamphlets publishing international applications under the PCT.

AL	Albania	ES	Spain	LS	Lesotho	SI	Slovenia
AM	Armenia	FI	Finland	LT	Lithuania	SK	Slovakia
AT	Austria	FR	France	LU	Luxembourg	SN	Senegal
AU	Australia	GA	Gabon	LV	Latvia	SZ	Swaziland
AZ	Azerbaijan	GB	United Kingdom	MC	Monaco	TD	Chad
BA	Bosnia and Herzegovina	GE	Georgia	MD	Republic of Moldova	TG	Togo
BB	Barbados	GH	Ghana	MG	Madagascar	TJ	Tajikistan
BE	Belgium	GN	Guinea	MK	The former Yugoslav Republic of Macedonia	TM	Turkmenistan
BF	Burkina Faso	GR	Greece	ML	Mali	TR	Turkey
BG	Bulgaria	HU	Hungary	MN	Mongolia	TT	Trinidad and Tobago
BJ	Benin	IE	Ireland	MR	Mauritania	UA	Ukraine
BR	Brazil	IL	Israel	MW	Malawi	UG	Uganda
BY	Belarus	IS	Iceland	MX	Mexico	US	United States of America
CA	Canada	IT	Italy	NE	Niger	UZ	Uzbekistan
CF	Central African Republic	JP	Japan	NL	Netherlands	VN	Viet Nam
CG	Congo	KE	Kenya	NO	Norway	YU	Yugoslavia
CH	Switzerland	KG	Kyrgyzstan	NZ	New Zealand	ZW	Zimbabwe
CI	Côte d'Ivoire	KP	Democratic People's Republic of Korea	PL	Poland		
CM	Cameroon	KR	Republic of Korea	PT	Portugal		
CN	China	KZ	Kazakstan	RO	Romania		
CU	Cuba	LC	Saint Lucia	RU	Russian Federation		
CZ	Czech Republic	LI	Liechtenstein	SD	Sudan		
DE	Germany	LK	Sri Lanka	SE	Sweden		
DK	Denmark	LR	Liberia	SG	Singapore		
EE	Estonia						

**AUTOMATIC LIQUID INJECTION SYSTEM AND METHOD****Field of the invention**

The present invention concerns the administration by  
5 injection to patients of liquid compositions for  
therapeutic or diagnostic purposes. It more particularly  
concerns a power assisted method and device for  
controllably dispensing a liquid medicament or  
10 diagnostically active contrast agent, the homogeneity of  
which is preserved throughout delivery. Typically, the  
contrast agent is an aqueous suspension of gas filled  
microvesicles, namely microbubbles bounded by a surfactant  
stabilized gas/liquid interface, or microballoons bounded  
15 by a tangible material envelope.

**Background Art**

Power injectors and mechanically assisted infusion  
systems for controllably dispensing therapeutically active  
medications are well known in the art. Typically, such  
20 devices include an automatic injector for syringes  
containing an injectable liquid and a plunger or piston  
movable within the barrel of the syringe to expel said  
liquid through a tip thereof and injecting into a patient  
via a tubing connected to an injecting needle or catheter.  
25 For controlling the injections parameters, the plunger is  
driven by means of an electromechanical arrangement  
organised to push the plunger at a desired rate,  
continuously or at chosen intervals, so that the amount of  
medication is delivered to the patient's body under  
30 strictly determined conditions. For instance, in the case  
of intravenous dispensing contrast agent formulations for  
diagnostic purposes (X-ray, MRI or ultrasound), the rate  
and the mode of injection can be accurately controlled to  
match the requirements of the imaging methods and detector  
35 systems used to investigate the circulation or a specific  
organ in the body. Typical automated injection devices are  
illustrated and described in US-5,176,646 incorporated  
herein by reference.

Although the automated injectors known are highly  
40 sophisticated instruments capable of mastering most

injection problems experienced in practice, there remains at least one variable factor not yet under control. Indeed the known power injectors have no control of the homogeneity of the liquid stored within the syringe barrel during the course of its application. This kind of problem is of course non-existent with "true solutions" (i.e. solutions to the molecular level) since in this case no concentration change can occur in the course of time; it however may become important when the injectable formulation is a suspension or dispersion of active particles which tend to settle, coalesce or segregate with time in the syringe. Indeed, even some modest separation of the particles by gravity or otherwise from the carrier liquid in the course of administration of the formulation may have very important influence on reproducibility and reliability of the tests. Hence, in this case, a method and means to keep the syringe content homogeneous during injection is highly desirable. The present method and device constitute a very effective solution to the aforesaid problem.

#### **Summary of the invention**

Briefly stated, in order to secure homogeneity of a liquid suspension of particles within the barrel of an injector device, the invention provides a method and means whereby the particles are kept under sufficient agitation so as not to settle, segregate or agglomerate in the carrier liquid. This may involve acting on the carrier liquid itself, i.e. on the bulk of the suspension, or may involve acting only on the particles (in this case, one would expect the moving particles to impart motion to the carrier liquid by viscous friction). The agitation means may be provided within the syringe or in some cases outside thereof; for instance with magnetic particles, the particles can be subjected to an external variable magnetic field, the oscillation or rotation of which will set them into motion, the moving particles then acting on the carrier liquid and keeping the suspension homogeneous.

In the case of particles not sensitive to external fields, mechanical agitation is provided to the extent that it is sufficient to keep the suspension homogeneous but insufficient to break or damage the particles or disturb  
5 their distribution. For this, the syringe barrel is subjected to motion, said motion being continuous or discontinuous, regular or irregular; the motion can possibly have a shaking, rocking or oscillating effect on the syringe. The frequency, intensity and rate of the  
10 motion is such that it will not interfere with the control of delivery parameters of the suspension.

The embodiments disclosed below in connection with the annexed drawings provides very effective means to keep the syringe content under sufficient agitation to secure  
15 injection of a homogeneous therapeutic or diagnostic liquid compositions into a patient.

#### Brief description of the drawings

Fig. 1 is a schematic view in perspective of a device  
20 for agitating a liquid within the syringe of a power driven automatic injector system of the invention.

Fig. 2 is a graph illustrating the homogeneity variations in a suspension of microbubbles contained in a syringe, the latter being either still or subjected to  
25 motion according to the invention.

Fig. 3 is a graph illustrating the gas volume and in vitro intensity of samples with and without treatment according to the invention.

Fig. 4a is a schematic view in perspective of another  
30 device for agitating a liquid within the syringe of a power driven automatic injector system of the invention. In this embodiment, the syringe is held by a supporting bracket, the latter being driven into motion by a motor.

Fig 4b is a schematical sectional view of the motor  
35 driving means of the embodiment of Fig 4a.

**Detailed description of the invention**

The device represented schematically in Fig. 1 comprises a series of co-operating elements mounted on a board 1. Such schematic representation of the present device is only for clarity and better understanding of the device's operation. Obviously, in its actual commercial construction, the device is in the form of a much more compact and sophisticated apparatus, for instance in the form of an instrument like the *Perfusor® fm* of the Firm BRAUN Meslungen AG, D-34209, Meslungen, Germany (displayed in Publication B.03.01.95 No 0879 0744), or like the apparatuses disclosed in US-A-4,652,260 and US-A-5,176,502, both being incorporated herein by reference.

The present device comprises the following working components: a syringe 2 shown in an uplifted position, an automatic power driving unit 3 for acting on the syringe, a pair of syringe motioning units 4 for liquid agitation, and a control box 14 for controlling operation of the units 4.

The syringe 2 has a barrel 5, a plunger 6 sliding in the barrel and a tip connector 7 linked to a tubing 8, the latter leading to an injection needle 9. The needle 9 is for injecting an administrable liquid into the tissues or the circulation of a patient.

The power driving unit 3 has an electromechanically controlled pusher rod 10 for acting on the rear end 11 of the syringe plunger, and a control knob 12 for setting the automatic driving parameters that will marshal the action of the rod 10.

Each unit 4 is equipped with two rollers 13, themselves driven into rotation by electric motors within the units and not represented in the drawing. The rotation of the rollers 13 is governed by means of a box 14 via lead wires 15 connected to said motors.

In operation, an injectable carrier liquid with particles (e.g. gas-filled microballoons) in suspension is introduced into the barrel 5 of the syringe 2 through the tip 7, this being consecutive to the retraction (manual or mechanical) of the plunger 6, so that an adequate pumping

action is provided. Then the syringe is placed on the rollers 13, so that the flange 16 thereof abuts the roller's edge 17, this being for retaining the syringe in its relative position against unwanted longitudinal translation. In this situation, the pushing rod 10 of the driving unit 3 couples with the plunger's end 11, so that any forward displacement of the rod 10 is transferred to the plunger with consequent expelling of the liquid toward the needle 9 for injection.

During injection, the rollers will alternately rotate the syringe a certain angle in one direction, say 30°, 60°, 90°, 180°, 270° or 360° and then, reciprocally, in the opposite direction. This balancing motion, which may be carried out in a stepwise manner, will move the liquid carrier to such an extent that any separation or segregation of the particles is hindered. This is very efficient for instance in the case of suspensions of gas-filled microbubbles used in echography since there is always a bubble size distribution in such suspensions, the larger bubbles tending to rise faster than the smaller ones by buoyancy. In a variant, the syringe can be made to rotate in one direction only, provided that the connector tip 7 thereof is made to freely rotate in order to prevent distortion of the tubing 8. Normally, the rate of rotation impressed by the rollers 13 is from about 0.5 to 200 rpm depending upon the suspension viscosity. This rate should be sufficient to keep the particles in homogeneous suspension but insufficient to break the particles or disturb their distribution in the carrier liquid. If necessary, in the case of more viscous suspensions, an additional vibrational motion of a few Hz to a few hundreds of Hz can be applied to the syringe by means of a pitch-fork or pitch-pipe. It should be mentioned that at very high rotation rates (e.g. 1,000 rpm or more) the radial speed may become dominant which will result in axial concentration of the microbubbles in the middle of the syringe. Rotational speeds at which the radial component becomes important are to be avoided as under such

conditions the suspension will become non-homogeneous again. This is clearly undesired.

In a variant, the unit 4 can have the form of a closable housing equipped with fixed syringe retaining means, i.e. other than the rollers edges 17 and, possibly if required, pressure resisting means (like a pressure mantle or jacket) in case the suspension is viscous and exerts undue pressure efforts to the syringe barrel. Also the syringe components can be made of moulded plastic (disposable syringes) and the barrel external surface provided with an integrally moulded relief pattern mating with corresponding pattern on the roller's surface, so that positive grip drive of the syringe is ensured.

Also, the rod 10 and the plunger 6 can be made integral with each other so that filling of the syringe can be controlled by the power unit 3, the pumping action then resulting from a backward displacement of rod 10.

The power unit per se is standard and its nature and operation well known to the skilled person. Embodiments thereof are disclosed in the cited references and also in US-A-5,456,670. The power unit usually contains an electrically powered and controlled helical screw means for mechanically advancing or retracting rod 10 continuously or intermittently, so that the liquid in the syringe can be dispensed continuously or by increments. The various parameters ruling said motions of the syringe piston can be monitored and adjusted by the control 12 and possible other control means not represented in the drawing. Means of unit 3 also ensure that such delivery parameters can be monitored and recorded for display. An instant stop switch (not shown) may also exist, in case the operation of the system should be suddenly interrupted due to a problem with the patient or otherwise.

It should be incidentally noted that although the present embodiment involves rocking the syringe only, one may also consider a modification involving a back and forth rotation of the pumping ensemble, this being achieved by

well known mechanical means adapted to support said pumping ensemble and to impart motion thereto.

Furthermore, although the present embodiment involves motion around the longitudinal axis, a variant may include  
5 rocking the syringe about a transversal axis.

A second device embodiment illustrated schematically in Fig 4a and 4b comprises a syringe 22 with a barrel 25 supported in a rotatable fashion by a bracket 30a-30b and a plunger 26 sliding in the barrel whose displacement therein  
10 is controlled by a power driven unit 23 capable of moving forward and backward in engagement with the back pusher end of the plunger 26. The device also comprises a motor driven unit 24 encompassing a portion 30b of the supporting bracket, the latter being rotated through gears 31, as  
15 better shown on Fig 4b, for agitation of a liquid suspension in the syringe barrel. The longitudinal forward or backward displacement of the unit 23 (acting on the plunger 26) is effected via a motor 31 which rotates a screw-bar 32, the latter engaging with a matching threaded  
20 portion (not shown) within the unit 23. The device further comprises an electronically computerized control box 34 for controlling operation of the units 23 (via motor 31) and 24, and for processing the signals from a laser detector 35 designed to read an identifying mark 36 on the syringe;  
25 this mark is for preventing errors in the selection of the syringe, especially if the syringe is of the prefilled type. The code of the mark can be according to standard bar codes. Note in this regard that since the syringe barrel is set into rotation in the present device, one can use a  
30 fixed detector instead of a mobile one which is advantageous designwise. By counting and recording via box 24 the number of turns of the screw bar 32, the position of the unit 23 (and consequently of the plunger 26) can be monitored and regulated at will. The control box 34 can of  
35 course comprise further monitoring and visualizing means (not shown) to optically display and appropriately regulate the various parameters involved in operation of the device. As in the previous embodiment, the syringe has a tip 27

for connecting to a liquid dispensing tubing 28, the latter leading to means for injecting an administrable liquid into a patient.

The operation of the present device is very similar to  
5 that of the earlier embodiment and hence needs not be discussed further at length. Suffice to say that it may also comprise security means intended to automatically interrupt the operation in case troubles develop with the patient or otherwise during injection. For instance, the  
10 pressure in the syringe barrel can be monitored by registering the force required to push the plunger, this being via the power absorbed by the driving motor 31. A sudden surge, for instance a rapid increase of current in said motor can trigger via the control unit 34 an emergency  
15 stop of the device. Alternatively, this effect could also be detected according to usual means by a strain gauge installed in the drive 23.

As already said, the particles of the suspensions in this invention may be of various kinds and involve for  
20 instance microspheres containing entrapped air or other gases used in echography. These microspheres may be bounded by a liquid/gas interface (microbubbles), or they may have a tangible membrane envelope of for instance synthetic polylactides or natural polymer like denatured protein such  
25 as albumin (microballoons). The carrier liquid for the microbubble suspensions comprises surfactants, preferably saturated phospholipids in laminar or lamellar form such as diacylphosphatidyl derivatives in which the acyl group is a C<sub>16</sub> or higher fatty acid residue.

30 The gases used in the microbubbles or microballoons are pure gases or gas mixtures including at least one physiologically acceptable halogenated gas. This halogenated gas is preferably selected among CF<sub>4</sub>, C<sub>2</sub>F<sub>6</sub>, C<sub>3</sub>F<sub>8</sub>, C<sub>4</sub>F<sub>8</sub>, C<sub>4</sub>F<sub>10</sub>, C<sub>5</sub>F<sub>12</sub>, C<sub>6</sub>F<sub>14</sub> or SF<sub>6</sub>. The gas mixtures can  
35 also contain gases such as air, oxygen, nitrogen, helium, xenon or carbon dioxide. In fact in a number of cases microbubbles or microballoons will contain mixtures of

nitrogen or air with at least one perfluorinated gas in proportions which may vary between 1 and 99%.

In the microballoons the membrane is made from a biodegradable material such as biodegradable polymers, solid triglycerides or proteins and are preferably selected from the polymers of polylactic or polyglycolic acid and their copolymers, denatured serum albumin, denatured haemoglobin, lower alkyl polycyanoacrylates, and esters of polyglutamic and polyaspartic acid, tripalmitin or tristearin, etc. In an embodiment, the microballoons are filled with  $C_3F_8$  and the material envelope is made of albumin.

Homogeneity of suspensions of microballoons whose membrane is made of saturated triglycerides such as tripalmitin, trimyristin or tristearin and their mixtures with other tri- or di- glycerides, fatty acids or polymers is particularly interesting as those are used for delivering active ingredients to specific sites within the body. Homogeneity of suspensions of such microballoons has been effectively maintained using the method and the device of the invention.

Other particles whose density is different from that of the carrier liquid may include liposomes filled with iodinated X-ray opacifiers such as iomeprol, iopamidol, iopentol, iohexol, metrizamide, iopromide, iogulamide, iosimide or ioversol or, for instance, coated and uncoated magnetic particles which tend to precipitate in saline or other carriers.

The present injector system can be used in imaging organs, blood vessels and tissues of mammals, e.g. the ultrasonic imaging of the heart, the liver or spleen, the brain, the kidneys, the blood vessels, etc.

The invention is further illustrated by the following Examples:

35

#### Example 1

A solution of gas filled microbubbles stabilised by a phospholipids interface was prepared according to

Example 1 of US 5,445,813. The dry matter concentration was 5 mg/ml in a saline solution (0.9% NaCl). Typically, the bubble size distribution extended from 0.2 to 15  $\mu\text{m}$ . The concentration of bubbles between 2 and 5  $\mu\text{m}$  was  $5 \times 10^7$  microbubble/ml.

The solution was transferred in a 50 ml plastic syringe and samples were taken in time intervals for analysis. This represent the starting 100% of the bubble concentration. The syringe was mounted in the infusion unit and the elution started. The elution flow was fixed at 1.6 ml/min.

Aliquots of the eluted solution were analysed by Coulter measurement (bubbles distribution; size and concentration) and imaging.

15

**Table 1**

Radius	Va	Radius	Va	Radius	Va	Radius	Va
1.0	0.131	4.5	2.648	8.0	8.368	11.5	17.291
1.5	0.294	5.0	3.269	8.5	9.446	12.0	18.828
2.0	0.523	5.5	3.955	9.0	10.590	12.5	20.429
2.5	0.817	6.0	4.707	9.5	11.800	13.0	22.096
3.0	1.177	6.5	5.524	10.0	13.075	13.5	23.829
3.5	1.602	7.0	6.407	10.5	14.415	14.0	25.626
4.0	2.092	7.5	7.355	11.0	15.820	14.5	27.489

In water, the rate of rise ( $V_a$ ) by buoyancy of air filled microbubbles of radius ( $a$ ) can be obtained from the following Stokes relation  $V_a = \frac{2gr}{9h} \times a^2$  where  $g$  is the gravitation constant ( $9.81 \text{ ms}^{-2}$ ),  $r$  is the density of water (1000 g/l) and  $h$  is the viscosity ( $10^{-3} \text{ Kg[s}\cdot\text{m}]$ ). Table 1 shows a range of such rates (in mm/min) in function to the bubble radius in  $\mu\text{m}$ . The tangential speed ( $V_r = 2\pi nR$ ) of a syringe barrel of 28 mm diameter ( $R = 14 \text{ mm}$ ) in function to the rotation rpm ( $n$ ) is given in the next Table 2.

25

**Table 2**

n (rpm)	V <sub>r</sub> (mm/min)
0.5	2539
1	5278
2	10556
3	15834
4	21112
5	26389
10	52779

It is seen from the foregoing figures that in the case of a suspension of microbubbles of size in the range of 1-10  $\mu\text{m}$ , very low rates of rotation of the syringe are sufficient to prevent segregation of the bubbles by buoyancy. This means that even at low rates of rotation the tangential speed of the microbubbles in suspension is much larger than buoyancy and that the microbubbles will move together with the rotating liquid and will not rise to the top of the syringe.

In a comparative study, the syringe was rotated along its axis in an alternative mode at a speed of 60 rpm. The results were compared with an experiment where the syringe was not rotated (under otherwise same experimental conditions).

Fig. 2 shows the evolution of the concentration of the total microbubble population and, separately, microbubbles above 8  $\mu\text{m}$  along the elution while Fig. 3 shows the evolution of imaging intensity and the total bubble volume in the course of elution. In the case of no-agitation, the concentration decreases rapidly due to decantation. At the end of the infusion, the concentration rises sharply (not shown) because all the bubbles accumulate in the upper part of the barrel.

When the syringe is rotated, the bubble concentration remains constant throughout the entire infusion.

The same type of experiments were carried out under different experimental conditions including different microbubbles sizes and concentrations, different elution rates, different rotation types and speed, different syringe types and different particles such as heavy magnetite particles or other microbubble structures including phospholipid, tripalmitin or albumin encapsulated microbubbles. All experiments invariably showed that the method of infusion disclosed delivers homogeneous suspensions of active agents.

#### Example 2

##### Preparation of contrast agents for infusion

To test the efficiency of the present invention (a system of rotary syringe pump), different contrast agents for ultrasound echography were prepared.

- Microbubble suspensions

Phospholipid stabilised microbubbles were obtained in the following manner. 500 mg DAPC and 50 mg DPPA (Avanti Polar Lipids, Inc.) were dissolved in hexane/iso-propanol 8/2 (v/v) and dried in a round-bottomed flask using a rotary evaporator and, further, in a vacuum dessicator. After addition of water (100 ml), the suspension of lipids was heated at 75°C for 1 hour under agitation and then extruded through a 0.8  $\mu\text{m}$  polycarbonate filter (Nuclepore®). The resulting suspension and 10 g of polyethyleneglycol ( $M_w$ 4000) were mixed and lyophilised. 2 g of the lyophilisate was introduced into a glass vial and sealed under  $\text{SF}_6$  or an air/ $\text{C}_4\text{F}_{10}$  mixture. After reconstitution with 25 ml NaCl 0.9%, the resulting suspensions contained about  $6 \times 10^8$  ( $\text{SF}_6$ ) or  $1 \times 10^9$  ( $\text{C}_4\text{F}_{10}$ ) bubbles per ml with a mean diameter in number of 2  $\mu\text{m}$  (Coulter Multisizer).

- Microballoon suspensions

Gas filled albumin microspheres were prepared as described by Porter T. R. (*J. Am. Coll. Cardio.* **23** (1994) 1440 and PCT/WO 96/38180). 16 ml of human serum albumin  
5 (HSA) diluted 1:3 with dextrose (5%) was introduced into a 20 ml syringe and sonicated (sonifier 250 Branson) for 80 seconds in the presence of a flux of C<sub>3</sub>F<sub>8</sub> gas (octafluoropropane) at liquid/air interface. The sonicator tip was immersed at about 1 cm below the surface of the  
10 solution, the ultrasound energy level was set at output -40 and the temperature of the solution was monitored at 75°C. After removing the foam phase by decantation, the final suspension contained 8x10<sup>8</sup> gas microspheres per millilitre with a mean diameter in number of 2 µm (9 µm in volume)  
15 determined by Coulter®. The suspensions are stored at 4°C until use.

Example 3

Determination of the limit of rotation rate for the  
20 syringe used for infusion

The effect of syringe rotation on stability of gas microbubble suspensions in the syringe used for infusion has been tested using a 50 ml syringe which was  
25 mounted on a rotation system which allows very low rotation speeds (about 1 rpm). Prior to its mounting the syringe was filled with 30 ml of phospholipid stabilised microbubble suspension. The mounted syringe was then rotated at different speeds: 0 (no rotation) 1.3, 2 and 60 rpm (1 Hz)  
30 and the suspension monitored taking one sample every 5 minutes. The samples were then analysed using Coulter counter. Table 3A shows the results obtained with a suspension of 3.1x10<sup>8</sup> microbubbles/ml having a mean diameter of 2.1 µm.

**Table 3A**

Homogeneity of microbubble suspensions in the syringe as a function of the rotation rate and time (microbubble concentration  $3.1 \times 10^8$  bubbles/ml)

5

Syringe rotation rates												
rpm	0	1.3	2	60	0	1.3	2	60	0	1.3	2	60
Vr	0	114	176	5278	0	114	176	5278	0	114	276	5278
t(min)	Nb total (%)				Nb>8 $\mu$ (%)				Volume (%)			
0	100	100	100	100	100	100	100	100	100	100	100	100
5	68.7	77.6	90.4	97.4	23.5	48.0	73.3	95.4	37.5	55.6	80.4	97.7
10	53.7	77.3	88.8	100.6	1.1	43.9	70.9	98.9	19.8	44.8	73.3	99.4
15	48.2	72.8	89.5	96.2	1.9	38.0	74.1	96.5	14.5	44.0	75.7	98.1
20	43.5	73.8	86.6	99.0	0.8	37.2	77.9	97.3	10.8	42.5	73.6	98.6
25	39.9	76.4	88.5	100.3	0.5	36.9	84.6	99.5	9.6	43.0	81.6	99.7

Nb total (%) : percentage of the total bubble concentration as compared to value at t=0.

10 Nb>8 $\mu$ (%) : percentage of the bubbles above 8 $\mu$ m as compared to value at t=0.

Volume (%) : percentage of total bubble volume per ml of solution as compared to value at t=0

rpm: rotation per minute; Vr (mm/min)=tangential speed of the syringe (radius=14mm)

15 Gas microbubbles: air/C<sub>4</sub>F<sub>10</sub> (50:50).

The above results clearly indicate that even at very low rotation rates (1.3 and 2 rpm), the buoyancy rise of the microbubbles is prevented. This is because even at 20 low rotation rates, the tangential velocity of the microbubble is far greater than that of buoyancy. As previously shown, microbubbles of 3 and 10  $\mu$ m have the respective rising rates of 0.29 and 3.3 mm/min. At 1.3 rpm rotation, the tangential speed is 114 mm/min ( $V_r = 2\pi \times \text{rpm} \times R_{\text{syringe}}$ ) which makes the tangential component of the 3  $\mu$ m 25 microbubble 390 times greater than the buoyancy. For 10  $\mu$ m

microbubble the tangential component is 35 times greater than the ascension rate. It should be mentioned that at very high rotation rates (e.g. 1,000 rpm) the microbubbles will concentrate in the middle of the syringe (as the radial component becomes dominant). Rotational speeds at which the radial component becomes important are not of interest as under such conditions the suspension becomes non-homogeneous again. The rotational speed at which the radial force is becoming significant depends on the syringe size (diameter, size of microbubbles and viscosity of the suspension) hence the exact value of the rotational speed at which the radial component becomes important is to be established for each individual case. However, as already pointed out such rotational speeds are to be avoided.

**Table 3B**

Homogeneity of microbubble suspensions in the syringe as a function of the rotation rate and time (microbubble concentration  $1.3 \times 10^9$  bubbles/ml)

/	Syringe rotation rates											
	0	3	12	60	0	3	12	60	0	3	12	60
rpm	0	3	12	60	0	3	12	60	0	3	12	60
Vr	0	264	1056	5278	0	264	1056	5278	0	264	1056	5278
t(min)	Nb total (%)				Nb > 8μ (%)				Volume (%)			
0	100	100	100	100	100	100	100	100	100	100	100	100
5	6.0	26.0	76.8	81.3	0.5	16.0	73.1	83.4	1.5	17.2	81.4	87.7
10	3.2	26.3	78.8	81.3	0.2	19.1	71.5	79.9	1.0	20.0	81.9	79.4
15	3.9	27.3	81.5	82.2	0.6	16.8	78.0	80.5	1.1	20.3	84.9	90.8
20	4.3	32.0	76.6	95.0	0.2	19.2	79.6	85.9	1.8	21.5	92.3	92.6
25	0	31.7	78.9	95.3	0	16.9	78.6	85.5	0	18.4	83.4	91.1

Nb total (%) : percentage of the total bubble concentration as compared to value at t=0.

Nb > 8μ (%) : percentage of the bubbles above 8μm as compared to value at t=0.

Volume (%) : percentage of total bubble volume per ml of solution as compared to value at t=0

rpm: rotation per minute;  $V_r$  (mm/min)=tangential speed of the syringe (radius=14mm)

Gas microbubbles: air/C<sub>4</sub>F<sub>10</sub>

5                   For more concentrated suspensions (e.g.  $1.3 \times 10^9$   
bubbles/ml) the microbubble ascension rate increases in the  
syringe. This is probably due to microbubble interactions  
(associations, dragg etc.) indicating that higher rotation  
speeds are required for prevention of microbubble ascension  
10 in the suspensions with higher microbubble concentrations.  
However, the lower limit of the syringe rotation is not  
easy to determine as the microbubble ascention rate is also  
a function of viscosity and density of the suspension, the  
nature of the gas used, the microbubble diameter and size  
15 distribution as well as the type of the microparticles  
(i.e. microbubbles having just a layer of a surfactant  
stabilising the gas, microballoon with a tangible membrane  
or microemulsion).

20                   Example 4

Evaluation of the efficiency of the rotary pump

A. Infusion of gas microbubble suspensions at low  
bubble concentration and "fast" infusion rate (3.3ml/min)

25                   In this study, the phospholipid stabilised gas  
microbubbles were prepared with a gas mixture  
of air/perfluorobutane 50 : 50) as gas phase.

                  The efficacy of the rotary pump of the present  
invention was evaluated by checking the homogeneity and  
30 stability of the bubble suspensions during the infusion.  
During a continuous infusion, the bubble suspensions were  
successively sampled at different infusion times with an  
interval of about every 5 minutes. The syringe used for  
infusion had a effective volume of 60 ml with a diameter of  
35 28 mm (Braun Perfusor, Germany). The rotation rate of the  
syringe was fixed at 60 rpm or 1 Hz (in order to compare  
different suspensions) and the direction of rotation was  
reversed for each turn. Infusion was stopped after 15

minutes while maintaining syringe rotation and then restored at the same rate during one minute after 30 minutes and 60 minutes. The bubble concentration, sizes and size distribution were assessed with Coulter® Multisizer II and the echo contrast effect of the suspensions was simultaneously examined with an echographic imaging device (Acuson 128XP10, USA). For Coulter® and echo evaluation, the native samples taken from the syringe were further diluted 1000 and 3000 folds (in some experiences 1/750). For *in vitro* imaging evaluation, an acoustic phantom ATS (Peripheral Vascular Doppler Flow Phantom, ATS Laboratories Inc., USA) was used and the image was visualised in B-mode with a 3.5 MHz ultrasound probe. The acoustic energy was set to minimum (-9dB) in order to prevent bubble destruction. The results are summarised in the Table 4.

**Table 4**

Evaluation of the efficacy of the rotary pump  
(Coulter and Echo imaging)  
Gas microbubbles: air/C<sub>4</sub>F<sub>10</sub>  
Pump flow rate : 3.3 ml/min

t(min)	Coulter measurement				Imaging
	Nbtot/mlx10 <sup>8</sup>	Nb>8μ/mlx10 <sup>6</sup>	Diam (μm)	Vol/ml	VI (pixels)
0	<b>3.26</b>	<b>4.90</b>	<b>2.09</b>	<b>7.33</b>	<b>62</b>
2	2.97	4.90	2.15	7.12	59
8	3.31	4.50	2.06	7.15	59
15	3.06	3.55	2.09	5.82	59
30	3.12	4.82	2.15	6.96	59
60	3.15	4.66	2.10	7.03	59

Nb>8μ/ml : number of bubbles above 8μm.

Nb total/ml : total bubble concentration.

Volume (μl/ml) : total bubble volume per ml of solution

Diameter (μm) : mean diameter in number.

VI : video intensity(dilution 1:3000)

These results show that even at a small rotation rate (1 Hz), the bubble suspension was fairly stable and homogeneous: both the total bubble count and bubbles > 8µm remain constant during the entire infusion.

5

B. Infusion of gas microbubble suspensions at high bubble concentration and "slow" infusion rate (1.2 ml/min)

The example A was repeated at a "slow" infusion rate and a higher concentration of the microbubbles. One can note from the Table 5 that even at very slow infusion rate (corresponding to 0.017 ml/kg/min for a 70 kg person) and a very high bubble concentration (Nb/ml > 10<sup>9</sup>/ml), the present rotary infusion pump is capable to ensure the stability and the imaging performance of the bubble suspensions during the entire infusion (24 min).

15

**Table 5**

Evaluation of the efficacy of the rotary pump (Coulter and Echo imaging)

20

Gas microbubbles: air/C<sub>4</sub>F<sub>10</sub>

Pump flow rate : 1.2 ml/min

t (min)	Coulter measurement				Imaging
	Nb/ml x 10 <sup>9</sup>	Nb > 8µ/ml x 10 <sup>7</sup>	Diameter (µm)	Volume/ml	VI (pixels)
<b>0</b>	<b>1.10</b>	<b>2.2</b>	<b>2.09</b>	<b>32.5</b>	<b>60</b>
5	1.03	2.2	2.15	30.9	60
13	1.01	2.1	2.06	30.5	55
18	1.03	2.1	2.09	30.0	58
24	1.04	2.1	2.15	30.5	57

Nb > 8µ/ml : number of bubbles above 8µm.

Nb total/ml : total bubble concentration.

25

Volume (µl/ml) : total bubble volume per ml of solution

Diameter (µm) : mean diameter in number.

VI : video intensity (dilution 1:3000)

Example 5

30

Evaluation of the efficacy of the rotary pump - comparative tests with and without syringe rotation

The procedure of Example 4 was repeated except that the phospholipid stabilised microbubbles were prepared with gas SF<sub>6</sub> instead of air/C<sub>4</sub>F<sub>10</sub>. Moreover, the stability of the gas bubble suspensions during infusion was compared using the same pump in the presence and absence of rotation of the syringe (R=28 mm, rotation rate = 60 rpm and 0 rpm). The experimental results of a concentrated bubble suspension (Nb > 10<sup>9</sup>/ml) infused at an infusion rate of 1.1 ml/min are shown in Table 6. Without syringe rotation, the amount of microbubbles delivered from the syringe decrease rapidly during infusion, especially for the large bubbles (see Nb > 8 μm and the volume). After 5 minutes of infusion, the total bubble concentration decreased by 83%, >99% for the bubbles larger than 8 μm and 90% for the bubble volume. After 10 minutes, the video intensity had decreased by a factor 3 and the contrast effect of the microbubbles was almost non detectable (IV = 6 ± 3 pixels for the background) at 10 minutes of the infusion. In contrast, in the presence of rotation the bubble suspension remained stable during the entire infusion (30 min).

**Table 6**

Evaluation of the efficacy of the rotary pump : comparative test

Gas microbubbles: SF<sub>6</sub>

Pump flow rate : 1.1 ml/min

t(min)	Coulter measurement								Imaging	
	Nb/ml x 10 <sup>9</sup>		Nb > 8 μ / ml x 10 <sup>7</sup>		Diameter (μm)		Volume /ml		VI (pixels)	
rot	with	w/out	with	w/out	with	w/out	with	w/out	with	w/out
0	1.2	1.1	1.58	1.32	2.09	2.22	24.3	20.4	32	54
5	1.16	0.19	1.41	0.008	2.09	2.14	22.6	2.0	30	16
10	1.06	0.15	1.37	0.012	2.13	1.96	21.4	1.2	30	10
15	1.15	0.13	1.38	0.00	2.11	1.92	22.5	0.9	30	8
20	1.38	0.12	1.81	0.00	2.13	1.83	28.5	0.7	31	7
30	1.25	0.11	1.53	0.00	2.11	1.79	24.4	0.6	32	6

Nb>8μ/ml : number of bubbles above 8μm.  
 Nb total/ml : total bubble concentration.  
 Volume (μl/ml) :total bubble volume per ml of solution  
 Diameter (μm) :mean diameter in number.  
 5 VI : video intensity(dilution 1:3000)

**Table 7**

Evaluation of the efficacy of the rotary pump :  
 comparative tests

10 Gas microbubbles: SF<sub>6</sub>  
 Pump flow rate : 3.3 ml/min

t(min)	Coulter measurements									
	Nb tot /mlx10 <sup>6</sup>		Nb>8μ /ml x10 <sup>6</sup>		Diam. (μm)		Vol. /ml		Vol %	
	with	w/out	with	w/out	with	w/out	with	w/out	with	w/out
<b>0</b>	<b>2.73</b>	<b>2.48</b>	<b>3.14</b>	<b>2.99</b>	<b>2.22</b>	<b>2.09</b>	<b>5.5</b>	<b>4.9</b>	<b>100.0</b>	<b>89.4</b>
5	2.57	2.05	3.21	0.5.4	2.23	1.94	5.3	2.1	96.7	39.1
10	2.53	1.71	3.42	0.01	2.27	1.81	5.8	1.1	105.7	20.6
15	2.48	1.41	3.28	0.00	2.28	1.64	5.2	0.6	96.1	10.8
20	2.35	1.16	1.33	0.00	2.21	1.54	4.6	0.5	83.6	8.3

Nb>8μ/ml : number of bubbles above 8μm.  
 Nb total/ml : total bubble concentration.  
 15 Volume (μl/ml) :total bubble volume per ml of solution  
 Diameter (μm) :mean diameter in number.  
 VI : video intensity(dilution 1:3000)

20 In Table 7, the comparative infusion was  
 conducted at a lower bubble concentration (2.7 10<sup>8</sup>/ml) and  
 an infusion rate of 3.3 ml/min. Again, these results show a  
 very good efficacy of the rotary infusion system to  
 maintain the homogeneity and stability of the microbubble  
 suspensions during infusion. In contrast, the syringe pump  
 25 without rotation was completely inadequate for microbubble  
 infusion.

Example 6

30 Evaluation of the efficiency of the rotary pump

Application to gas microspheres (comparative tests)

The Example 5 was repeated with the gas albumin microspheres prepared as described in Example 2. For the infusion, the bubble concentration was adjusted to  $6 \times 10^8$ /ml by diluting the suspension with HSA/dextrose (1:3). In the present experience, the in vitro characteristics of the microspheres during infusion (2.7 ml/min) with and without the syringe rotation were compared to assess the homogeneity of the suspensions delivered from the syringe. The results are gathered in Table 8.

**Table 8**

Evaluation of the efficacy of the rotary infusion pump with gas albumin microspheres  
 Gas microbubbles:  $C_3F_8$   
 Pump flow rate : 2.7 ml/min

t(min)	Coulter measurements									
	Nbtot /ml $\times 10^8$		Nb $>8\mu$ /ml $\times 10^6$		Diam ( $\mu$ m)		Vol /ml		VI (pixels)	
rot	with	w/out	with	w/out	with	w/out	with	w/out	with	w/out
0	6.64	6.7	9.6	7.6	2.03	1.97	15.4	12.3	47	46
5	6.4	6.6	8.0	4.5	1.96	1.93	13.1	8.8	47	38
10	6.4	6.3	6.0	2.6	1.91	1.8	10.3	5.0	45	23
15	6.4	6.0	6.5	0.38	1.92	1.65	10.5	3.5	45	19
20	6.25	5.2	6.15	0.15	1.92	1.61	9.9	3.8	43	26

Nb $>8\mu$ /ml : number of bubbles above  $8\mu$ m.

Nb total/ml : total bubble concentration.

Volume ( $\mu$ l/ml) : total bubble volume per ml of solution

Diameter ( $\mu$ m) : mean diameter in number.

VI : video intensity(dilution 1:3000)

Background : VI = 9 pixels

The albumin microspheres appear to be more homogeneous in the syringe than phospholipid microbubbles in the absence of rotation. This is likely to be due to the higher viscosity of the albumin/dextrose solution (5%) and possibly to the thicker wall of the microspheres (about 15 times thicker than a phospholipid monolayer). Nevertheless,

large microspheres ( $>8\mu\text{m}$ ) still decanted in the syringe and their concentration decreased progressively during infusion. After 10 minutes, the volume of microspheres and the video intensity decreased to half of the initial values. It was been reported that the myocardial perfusion with a similar agent - FS069 (Optison<sup>®</sup>, HSA-C<sub>3</sub>F<sub>8</sub> microsphere suspensions) was attributed essentially to a small number of large microspheres (10-15  $\mu\text{m}$ ) entrapped in the tissue (Skyba et al., *J. Am. Coll. Cardio.* **28** (1996) 1292-1300). Therefore, on can speculate that for such clinical application this kind of contrast agents could hardly be infused by a classic infusion pump as demonstrated in the present example.

15        Example 7

Tetracaine filled tripalmitin microcapsules made according to Example 6 of WO96/15815 were suspended in 50 ml of saline solution (0.9% NaCl). The suspension with a concentration of tetracaine of 0.06 mg/ml was placed into a 50 ml syringe. The syringe was placed on the rotational pump of the invention and the exit concentration of tetracaine measured using UV spectrophotometer (in THF/water 60/40% at 307 nm). The syringe was rotated at a rate of 1Hz (alternating direction of rotation every 180°). The rate of infusion was 1.5 ml/min. The UV analysis showed constant concentration of tetracaine over the entire period of infusion. In the parallel experiment in which the tetracaine filled syringe was kept stationary the exit concentration of the medicament varied with time.

30        Example 8

Fifty milligrams of Amphotericin B in the deoxycholate form (Fungizone<sup>®</sup> Bristol Mayers Squibb) were dispersed in 50 ml of Intralipid<sup>®</sup> 20% (Pharmacia) and the emulsion obtained (Chavanet, P., *Rev. Med. Interne* **18** (1997) 153-165) introduced into a 50 ml syringe. The

syringe was placed on the rotational pump and infused at 1 ml/min rate and rotation of 1 Hz (alternating direction of rotation every 360°. Exit concentration of Amphotericin B was followed by HPLC (detection UV/visible at 405 nm). The HPLC analysis confirmed constant concentration of the medicament during the entire infusion. The experiment clearly showed that the separation of Amphotericin B reported by several research groups (Trissel, L. A., *Am. J. Health Syst. Pharm.* **52** (1995) 1463; Owens, D., *Am. J. Health Syst. Pharm.* **54** (1997) 683) was successfully suppressed using the method disclosed.

#### Example 9

A liposome solution was prepared from 9/1 molar ratio of hydrogenated soy lecithin (DPPC) and dipalmitoylphosphatidic acid disodium salt (DPPA) in chloroform according to a well known procedure (e.g. EP 0 514 523). After extrusion and cooling of MLV suspension the same was concentrated to 30 mg/ml by microfiltration. To 1 l of the concentrated liposome solution, 1 l of an aqueous solution containing 1040 g of (S)-N,N'-bis [2-hydroxy-1-(hydroxymethyl)-ethyl]-2,4,6-triiodo-5-lactamido-isophthalamide (Iopamidol®, an X-ray contrast agent of BRACCO S.p.A.) was added and the resulting mixture having an iodine concentration of 260 g/l was incubated. The density of the Iopamidol® solution was 1.29 g/cm<sup>3</sup>.

An aliquot of the liposome preparation was dialyzed against saline (NaCl 0.9% in water) until all iopamidol outside the liposomes vesicles was removed. The iodine-to-lipid ratio of the preparation obtained (I/L) was between 3 and 5 mg of entrapped iodine per mg lipid.

Part of the preparation of contrast agent-loaded liposomes was introduced into a syringe which was placed on the rotational pump of the invention and the exit concentration of the contrast agent measured using HPLC. The syringe was rotated at a rate of 1Hz (alternating direction of rotation every 180°). The rate of infusion was

1.5 ml/min. The HPLC analysis showed constant concentration of the iodinated contrast agent over the entire period of infusion.

When, in the foregoing example, the Iopamidol was  
5 replaced by Iomeprol (N,N'-bis(2,3-dihydroxypropyl)-2,4,6-triiodo-5-glycolamido-isophtal-imide), another iodinated contrast agent from BRACCO S.p.A., similar results were experienced.

Claims

1. A method of administering to patients by injection or infusion a suspension of microparticles  
5 homogeneously distributed in an aqueous liquid carrier by means of an injector system comprising a syringe containing said suspension and a power driven piston for injecting said suspension into a patient, characterised by subjecting  
10 the suspension in the syringe to a rotation or rocking motion, thereby maintaining said suspension homogeneous by preventing segregation of the microparticles by gravity or buoyancy, this being without damaging said particles or disturbing their distribution.

15 2. The method of claim 1, in which said motion is provided by outside means for imparting motion to said particles, which motion is then transferred to said liquid carrier.

20 3. The method of claim 1, in which said motion of rocking or rotation is alternated.

4. The method of claim 3, in which said motion is applied along or around the syringe longitudinal or  
25 transverse axis.

5. The method of claim 4, in which said motion is provided by subjecting the syringe to continuous or  
30 intermittent rotation.

6. The method of claim 5, in which the rotation rate is from 0.5 to 200 rpm.

7. The method of anyone of preceding claims, in  
35 which said motion is alternating rotation the direction of which is reversed every 30°, 60°, 90°, 180°, 270° or 360°.

8. The method of claim 7, in which the direction is alternated at a frequency of 0.5 Hz, 1.0, Hz, 1.5 Hz, 2.0 Hz, 2.5 Hz, 3.0 Hz or 3.5 Hz.

5 9. The method of anyone of preceding claims, in which said motion is carried out stepwise.

10 10. An injector system for administering to patients by injection or infusion a suspension of microparticles in an aqueous liquid carrier, said system comprising a syringe (22) whose barrel (25) contains said suspension, and automatic electromechanical power means (24, 31, 34) controllably acting on the syringe to inject the suspension into a patient, characterised in that said injector system  
15 further comprises means (30a, 30b) for agitating said microparticles in said suspension, said agitation keeping said suspension homogenous by preventing segregation of said particles by gravity or buoyancy without damaging said particles or disturbing their distribution.

20

11. The injector system of claim 10, in which said means (30a, 30b) for agitating the suspension in the syringe constitute means under motion for supporting the syringe in the system, the effect of said motion applied to  
25 the syringe being to agitate the liquid in the syringe barrel.

12. The injector system of claim 11, in which said motion is a rotation.

30

13. The injector system of claim 10 in which said injection means acting on the syringe include a syringe plunger (26) driven into forward or backward motion by helical screw means (23, 31, 32).

35

14. The injector system of claim 13, in which the position of the plunger in the syringe is governed by a

number of turns of said helical screw means as controlled by said automatic power means (31, 34).

15 15. The injector system of claim 12, characterized in that said means under rotation are constituted by wheels (13) in in contact with the syringe barrel for driving it into consecutive rotation.

10 16. The injector system of claim 12, in which the syringe rotates alternatively in one and the opposite direction.

15 17. The injector system of claim 16, in which the angle covered in each alternate rotation is 30°, 60°, 90°, 180°, 270° or 360°.

18. The injector system of claim 11, in which the rotation rate of the syringe is from 0.5 to 200 rpm.

20 19. The injector system of claim 11, further comprising a fixed laser detector for reading identification marks provided on the syringe.

25 20. The injector system of claim 10, further comprising safety means for interrupting the injector operation in case of emergency.

30 21 The injector system of claim 20, in which said security means operate by monitoring the force applied to the syringe during injection, a sudden increase of that force producing a signal for stopping the injector operation.

35 22. The injector system of anyone of claims 10-21, in which the suspension is a contrast agent for ultrasonic imaging of patients.

23. The injector system of claim 22, in which the contrast agent comprises, in suspension in an aqueous liquid carrier, gas filled microvesicles which are either microbubbles bounded by a gas/liquid interface made from dissolved surfactants, or microballoons bounded by a material envelope made of organic polymers, or of di- or tri- glycerides.

24. The injector system of claim 23, in which the gas is a pure physiologically acceptable halogenated gas or gas mixture comprising at least one physiologically acceptable halogenated gas.

25. The injector system of claim 24, in which the halogenated gas is selected from  $CF_4$ ,  $C_2F_6$ ,  $C_3F_8$ ,  $C_4F_8$ ,  $C_4F_{10}$ ,  $C_5F_{12}$ ,  $C_6F_{14}$  or  $SF_6$ .

26. The injector system of claim 24, wherein the gas mixture contains a gas selected from air, oxygen, nitrogen, helium, xenon or carbon dioxide.

27. The injector system of anyone of claims 23-26, in which at least one of the surfactants is a saturated phospholipid in a lamellar or laminar form.

28. The injector system of claim 27, in which at least one of the phospholipids is a diacylphosphatidyl compound wherein the acyl group is a  $C_{16}$  fatty acid residue or a higher homologue thereof.

29. The injector system of claim 23, in which the polymer of the membrane is selected from polylactic or polyglycolic acid and their copolymers, denatured serum albumin, denatured haemoglobin, polycyanoacrylate, and esters of polyglutamic and polyaspartic acids.

30. The injector system of claim 29, in which the microballoons are filled with  $C_3F_8$  and the material envelope is made from albumin.

5 31. The injector system of claim 23, in which the microballoons are bounded by saturated triglycerides, preferably tristearine, tripalmitine or mixtures of thereof with other glycerides, fatty acids and biodegradable polymers.

10

32. The injector system of anyone of claims 10-31, in which the suspension is a contrast agent for CT imaging.

15 33. The injector system of claim 32, in which the contrast agent comprises as a suspension in a liquid carrier phase liposomes filled with an iodinated compound selected from iomeprol, iopamidol, iopentol, iohexol, metrizamide, iopromide, iogulamide, iosimide or ioversol.

20 34. The injector system of claim 33, in which iodine over lipid ratio I/L is 3 or more.

25 35. Use of the injector system according to anyone of claims 10-34 in imaging of organs, blood vessels and tissues of a mammalian.

30 36. Use of claim 35, in which the imaging is ultrasonic imaging and the organ is the heart, the brain, the kidneys, the liver.

37. Use of the injector system according to anyone of claims 10-34 in imaging of organs, blood vessels and tissue of a mammalian.

35 38. Use according to claim 37, in which the imaging is CT imaging and the organ is the liver.

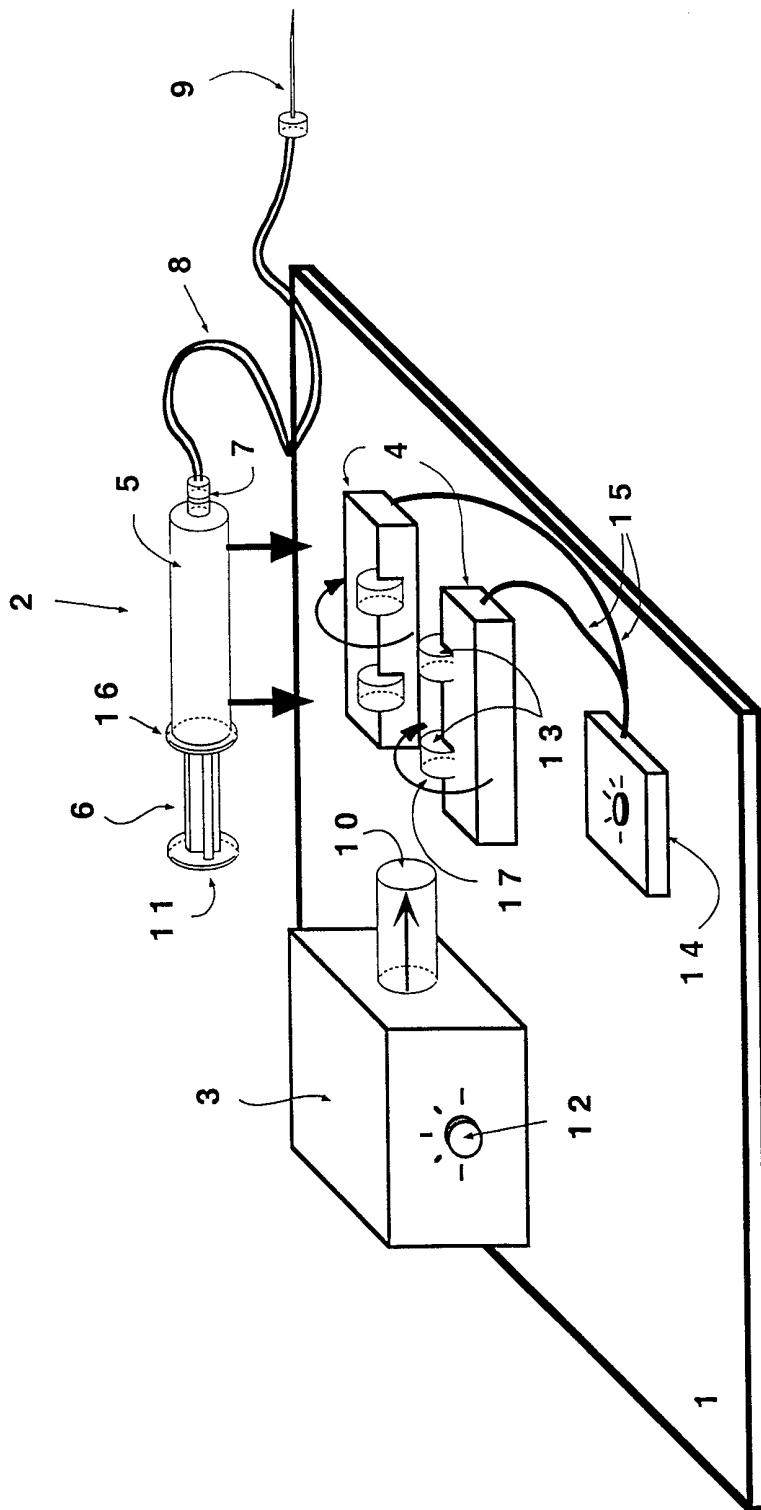

Fig. 1

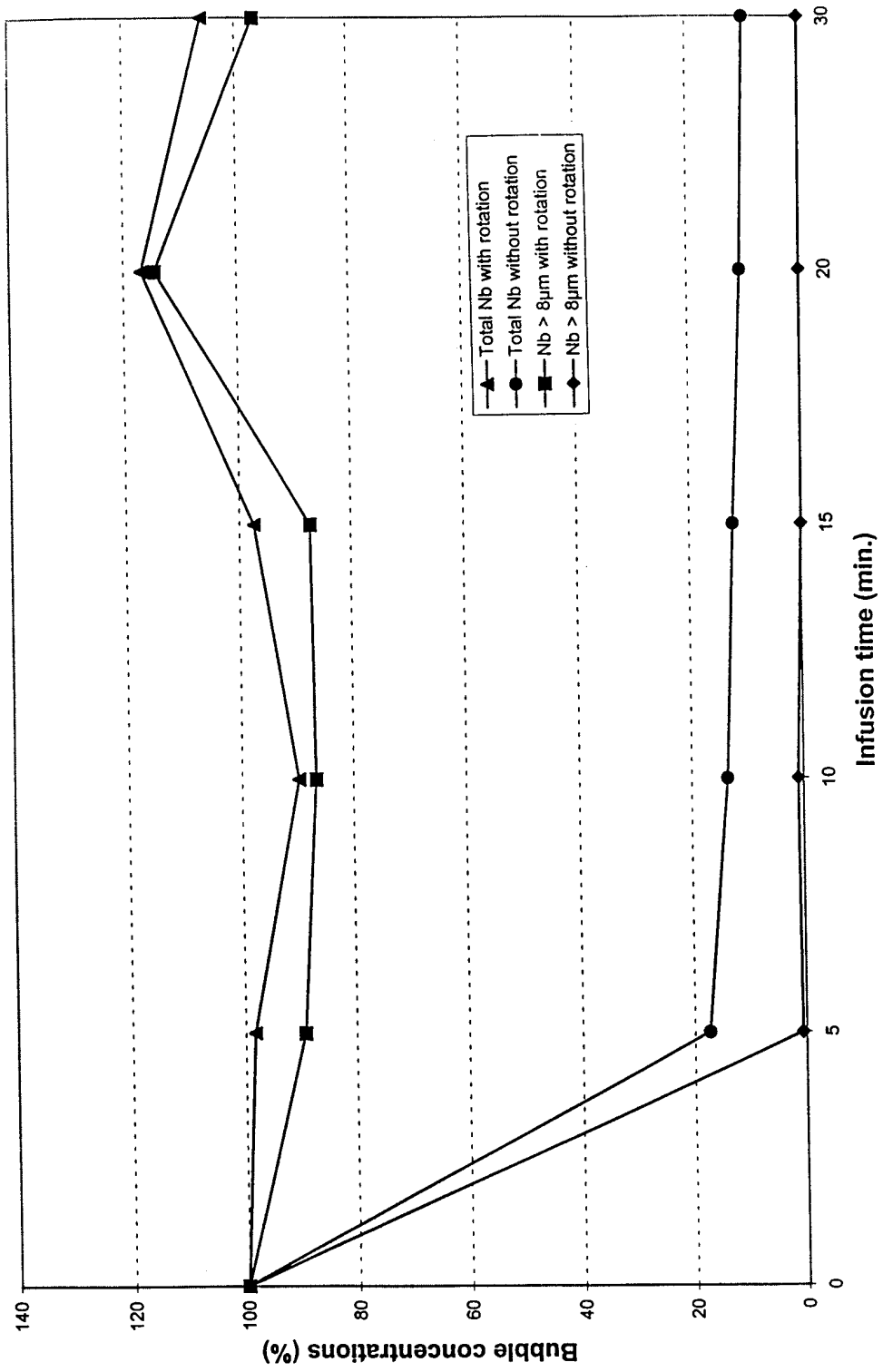

Fig. 2

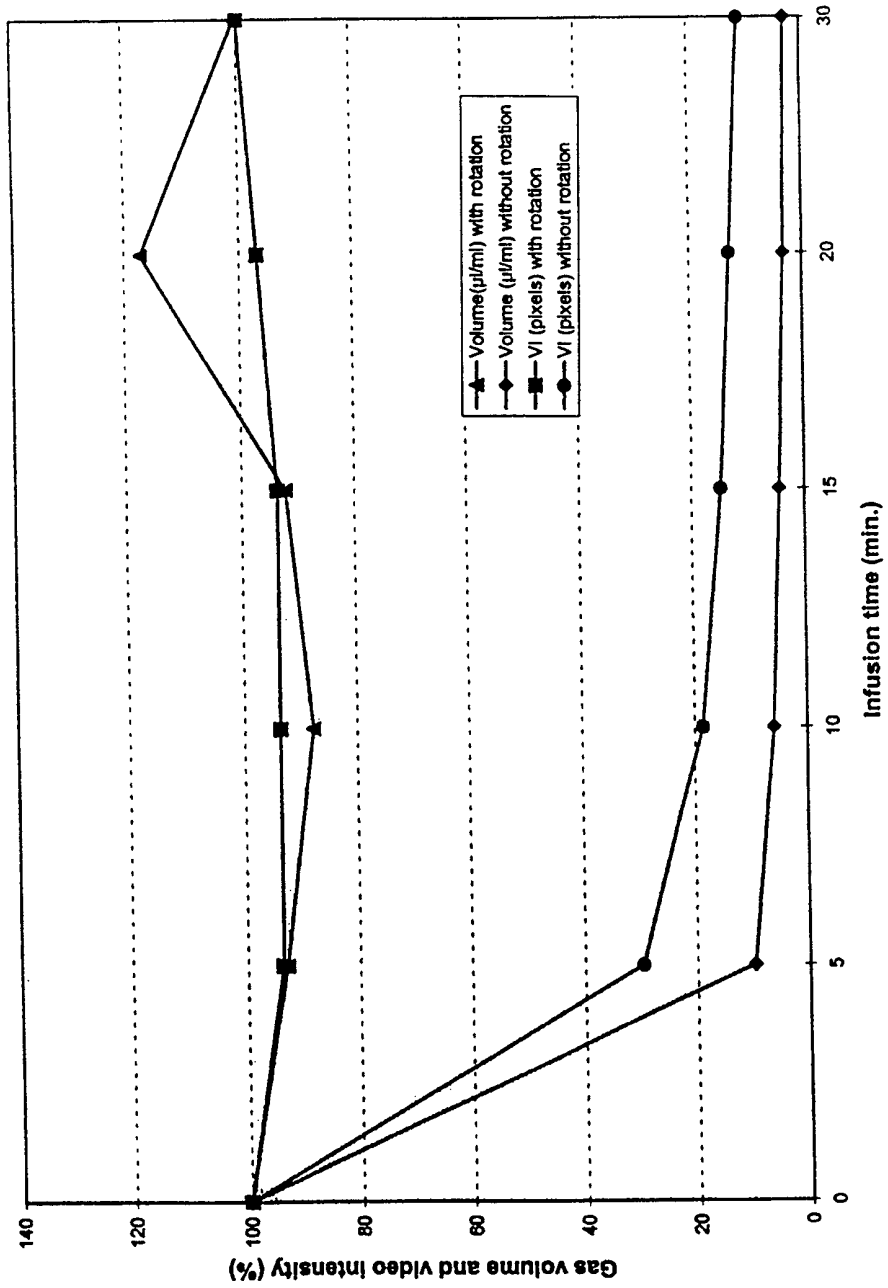

Fig. 3

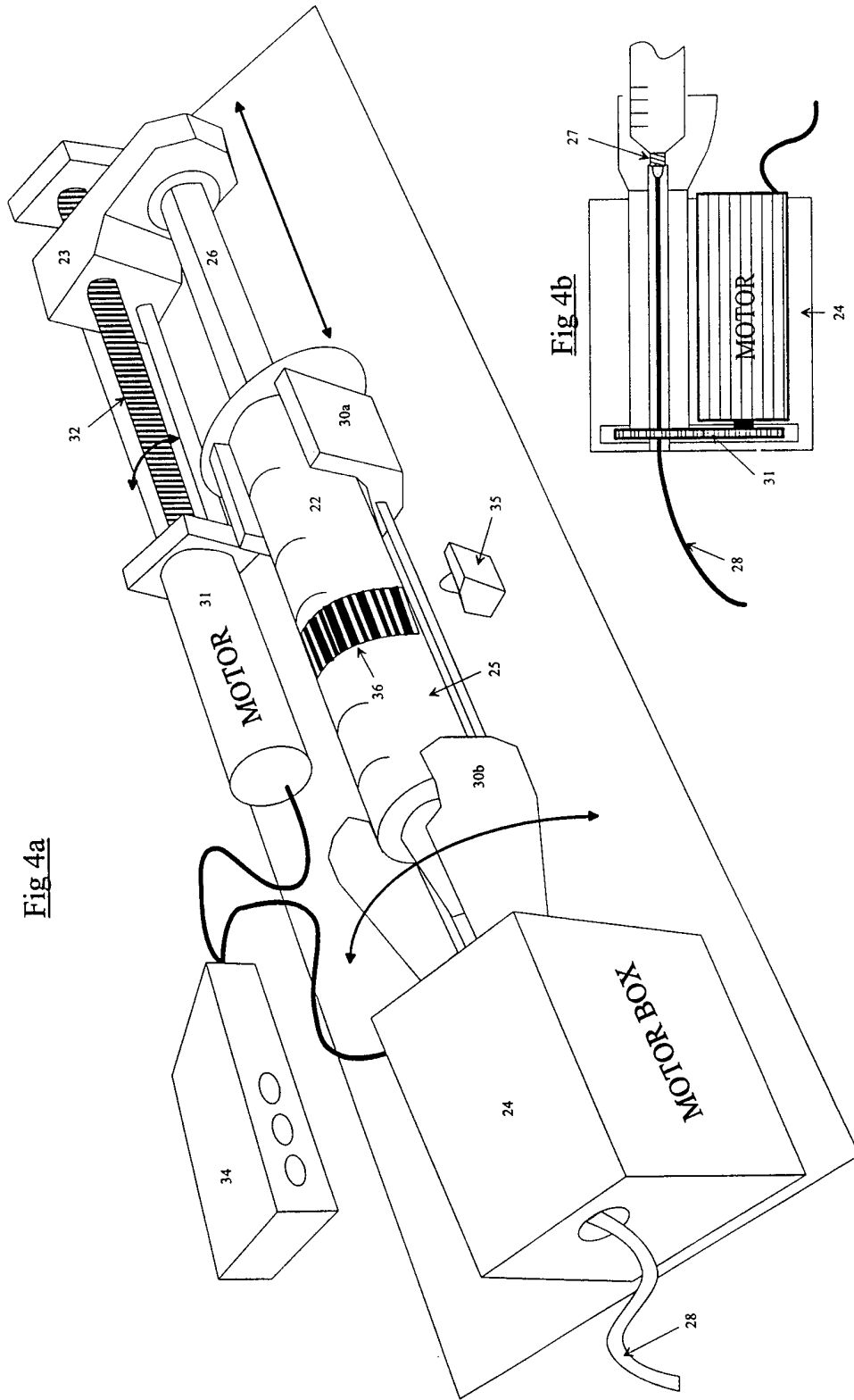

Fig 4a

Fig 4b

# INTERNATIONAL SEARCH REPORT

International Application No

PCT/IB 98/01938

<b>A. CLASSIFICATION OF SUBJECT MATTER</b> IPC 6 A61M5/145				
According to International Patent Classification (IPC) or to both national classification and IPC				
<b>B. FIELDS SEARCHED</b>				
Minimum documentation searched (classification system followed by classification symbols) IPC 6 A61M				
Documentation searched other than minimum documentation to the extent that such documents are included in the fields searched				
Electronic data base consulted during the international search (name of data base and, where practical, search terms used)				
<b>C. DOCUMENTS CONSIDERED TO BE RELEVANT</b>				
Category °	Citation of document, with indication, where appropriate, of the relevant passages	Relevant to claim No.		
Y	WO 96 18420 A (BRACCO RESEARCH S.A.) 20 June 1996 see page 5, line 10 - line 17 ---	10		
Y	FR 2 429 600 A (HYCO & AULAS ETS) 25 January 1980 see page 2, line 14 - line 26; claim 2; figure 1 ---	10		
A	OWENS D. ET AL: "Stability of amphotericin B 0.05 and 0.5 mg/mL in 20% fat emulsion" AM. J. HEALTH-SYST. PHARMACISTS, vol. 54, 15 March 1997, pages 683-686, XP002064707 cited in the application see page 685, right-hand column, paragraph 2 ---	10		
-/--				
<input checked="" type="checkbox"/> Further documents are listed in the continuation of box C.				
<input checked="" type="checkbox"/> Patent family members are listed in annex.				
° Special categories of cited documents :				
<table style="width: 100%; border: none;"> <tr> <td style="width: 50%; border: none; vertical-align: top;">                     "A" document defining the general state of the art which is not considered to be of particular relevance                      "E" earlier document but published on or after the international filing date                      "L" document which may throw doubts on priority claim(s) or which is cited to establish the publication date of another citation or other special reason (as specified)                      "O" document referring to an oral disclosure, use, exhibition or other means                      "P" document published prior to the international filing date but later than the priority date claimed                 </td> <td style="width: 50%; border: none; vertical-align: top;">                     "T" later document published after the international filing date or priority date and not in conflict with the application but cited to understand the principle or theory underlying the invention                      "X" document of particular relevance; the claimed invention cannot be considered novel or cannot be considered to involve an inventive step when the document is taken alone                      "Y" document of particular relevance; the claimed invention cannot be considered to involve an inventive step when the document is combined with one or more other such documents, such combination being obvious to a person skilled in the art.                      "&amp;" document member of the same patent family                 </td> </tr> </table>			"A" document defining the general state of the art which is not considered to be of particular relevance "E" earlier document but published on or after the international filing date "L" document which may throw doubts on priority claim(s) or which is cited to establish the publication date of another citation or other special reason (as specified) "O" document referring to an oral disclosure, use, exhibition or other means "P" document published prior to the international filing date but later than the priority date claimed	"T" later document published after the international filing date or priority date and not in conflict with the application but cited to understand the principle or theory underlying the invention "X" document of particular relevance; the claimed invention cannot be considered novel or cannot be considered to involve an inventive step when the document is taken alone "Y" document of particular relevance; the claimed invention cannot be considered to involve an inventive step when the document is combined with one or more other such documents, such combination being obvious to a person skilled in the art. "&" document member of the same patent family
"A" document defining the general state of the art which is not considered to be of particular relevance "E" earlier document but published on or after the international filing date "L" document which may throw doubts on priority claim(s) or which is cited to establish the publication date of another citation or other special reason (as specified) "O" document referring to an oral disclosure, use, exhibition or other means "P" document published prior to the international filing date but later than the priority date claimed	"T" later document published after the international filing date or priority date and not in conflict with the application but cited to understand the principle or theory underlying the invention "X" document of particular relevance; the claimed invention cannot be considered novel or cannot be considered to involve an inventive step when the document is taken alone "Y" document of particular relevance; the claimed invention cannot be considered to involve an inventive step when the document is combined with one or more other such documents, such combination being obvious to a person skilled in the art. "&" document member of the same patent family			
Date of the actual completion of the international search  <p style="text-align: center; font-size: 1.2em;">9 April 1999</p>		Date of mailing of the international search report  <p style="text-align: center; font-size: 1.2em;">20/05/1999</p>		
Name and mailing address of the ISA European Patent Office, P.B. 5818 Patentlaan 2 NL - 2280 HV Rijswijk Tel. (+31-70) 340-2040, Tx. 31 651 epo nl, Fax: (+31-70) 340-3016		Authorized officer  <p style="text-align: center; font-size: 1.2em;">Sedy, R</p>		

# INTERNATIONAL SEARCH REPORT

International Application No

PCT/IB 98/01938

**C.(Continuation) DOCUMENTS CONSIDERED TO BE RELEVANT**

Category	Citation of document, with indication, where appropriate, of the relevant passages	Relevant to claim No.
A	US 5 401 253 A (REYNOLDS) 28 March 1995 see column 3, line 7 - line 12 ---	10
A	US 5 528 923 A (LEDEZ ET AL.) 25 June 1996 see column 18, line 57 - line 58 see column 19, line 55 - line 58 ---	10,11
A	US 5 686 060 A (SCHNEIDER ET AL.) 11 November 1997 see column 10, line 16 - line 18 see column 12, line 33 - line 36 see column 12, line 53 - line 57 ---	10,27
A	FR 2 220 228 A (METAC S.A.) 4 October 1974 see page 1, line 17 - line 22 ---	11
A	US 5 611 344 A (BERNSTEIN ET AL.) 18 March 1997 see column 3, line 33 - line 34 see column 6, line 24 - line 31 see column 6, line 54 - line 64 see column 8, line 45 - line 47 see column 8, line 66 - line 67 -----	22-26, 31,36,38

# INTERNATIONAL SEARCH REPORT

International application No.

PCT/IB 98/01938

## Box I Observations where certain claims were found unsearchable (Continuation of item 1 of first sheet)

This International Search Report has not been established in respect of certain claims under Article 17(2)(a) for the following reasons:

1.  Claims Nos.: 1-9  
because they relate to subject matter not required to be searched by this Authority, namely:  
  
Rule 39.1(iv) PCT - Method for treatment of the human or animal body by surgery
2.  Claims Nos.:  
because they relate to parts of the International Application that do not comply with the prescribed requirements to such an extent that no meaningful International Search can be carried out, specifically:
3.  Claims Nos.:  
because they are dependent claims and are not drafted in accordance with the second and third sentences of Rule 6.4(a).

## Box II Observations where unity of invention is lacking (Continuation of item 2 of first sheet)

This International Searching Authority found multiple inventions in this international application, as follows:

1.  As all required additional search fees were timely paid by the applicant, this International Search Report covers all searchable claims.
2.  As all searchable claims could be searched without effort justifying an additional fee, this Authority did not invite payment of any additional fee.
3.  As only some of the required additional search fees were timely paid by the applicant, this International Search Report covers only those claims for which fees were paid, specifically claims Nos.:
4.  No required additional search fees were timely paid by the applicant. Consequently, this International Search Report is restricted to the invention first mentioned in the claims; it is covered by claims Nos.:

Remark on Protest

- The additional search fees were accompanied by the applicant's protest.
- No protest accompanied the payment of additional search fees.

# INTERNATIONAL SEARCH REPORT

Information on patent family members

International Application No

PCT/IB 98/01938

Patent document cited in search report	Publication date	Patent family member(s)	Publication date
WO 9618420      A	20-06-1996	AU 701807 B	04-02-1999
		AU 3935295 A	03-07-1996
		CA 2181340 A	20-06-1996
		CN 1141001 A	22-01-1997
		CZ 9602420 A	13-11-1996
		EP 0744962 A	04-12-1996
		FI 963202 A	15-08-1996
		JP 9509433 T	22-09-1997
		NO 963327 A	09-08-1996
		NZ 295744 A	22-08-1997
		US 5827504 A	27-10-1998
		US 5830435 A	03-11-1998
		ZA 9510721 A	20-06-1996
<hr style="border-top: 1px dashed black;"/>			
FR 2429600      A	25-01-1980	NONE	
<hr style="border-top: 1px dashed black;"/>			
US 5401253      A	28-03-1995	GB 2274064 A	13-07-1994
<hr style="border-top: 1px dashed black;"/>			
US 5528923      A	25-06-1996	CA 2112004 A	22-06-1994
<hr style="border-top: 1px dashed black;"/>			
US 5686060      A	11-11-1997	AT 146972 T	15-01-1997
		AU 2618197 A	18-12-1997
		AU 681812 B	04-09-1997
		AU 3431795 A	04-01-1996
		AU 666238 B	01-02-1996
		AU 5336294 A	24-05-1994
		CA 2125027 A, C	11-05-1994
		CN 1088456 A	29-06-1994
		DE 69307124 D	13-02-1997
		DE 69307124 T	17-07-1997
		DK 619743 T	20-01-1997
		WO 9409829 A	11-05-1994
		EP 0619743 A	19-10-1994
		ES 2097548 T	01-04-1997
		FI 943167 A	01-07-1994
		GR 3022826 T	30-06-1997
		HU 74561 A	28-01-1997
		IL 107453 A	04-01-1998
		JP 7503254 T	06-04-1995
		NO 942476 A	30-06-1994
NZ 257115 A	24-06-1997		
NZ 280615 A	24-02-1997		
US 5445813 A	29-08-1995		
US 5597549 A	28-01-1997		
ZA 9308117 A	23-06-1994		
<hr style="border-top: 1px dashed black;"/>			
FR 2220228      A	04-10-1974	NONE	
<hr style="border-top: 1px dashed black;"/>			
US 5611344      A	18-03-1997	AU 2139297 A	22-09-1997
		CA 2247151 A	12-09-1997
		CZ 9802812 A	13-01-1999
		EP 0904113 A	31-03-1999
		NO 984089 A	04-09-1998
		NZ 331460 A	23-12-1998
		PL 328690 A	15-02-1999
		WO 9732609 A	12-09-1997
		US 5853698 A	29-12-1998
		<hr style="border-top: 1px dashed black;"/>	