

(19)



Europäisches Patentamt

European Patent Office

Office européen des brevets



(11)

EP 0 916 462 A2

(12)

EUROPEAN PATENT APPLICATION

(43) Date of publication:

19.05.1999 Bulletin 1999/20

(51) Int Cl.6: **B28C 7/00**

(21) Application number: **98203671.7**

(22) Date of filing: **30.10.1998**

(84) Designated Contracting States:

**AT BE CH CY DE DK ES FI FR GB GR IE IT LI LU
MC NL PT SE**

Designated Extension States:

AL LT LV MK RO SI

(72) Inventor: **Ermes, Bigi**

Nuova, 118/E-F-G, 41042 Fiorano (MODENA) (IT)

(74) Representative: **Corradini, Corrado et al**

Studio Ing. C. CORRADINI & C. S.r.l.

4, Via Dante Alighieri

42100 Reggio Emilia (IT)

(30) Priority: **11.11.1997 IT RE970085**

(71) Applicant: **L.B. Officine Meccaniche S.p.A.**

41042 Fiorano Modenese (Modena) (IT)

(54) **Method and apparatus for preparing coloured materials in powder form for tile manufacture, and coloured materials obtained thereby**

(57) The method for preparing coloured materials in powder form for ceramic tile manufacture comprises feeding a mixing device (6) with a mass of atomized or granulated ceramic material the granules of which are

of statistically equal size and do not contain added colorants, and a metered quantity of fine coloured particles of much smaller size than said granules, then mixing the entirety until the outer surface of said granules is completely covered by said fine coloured particles.

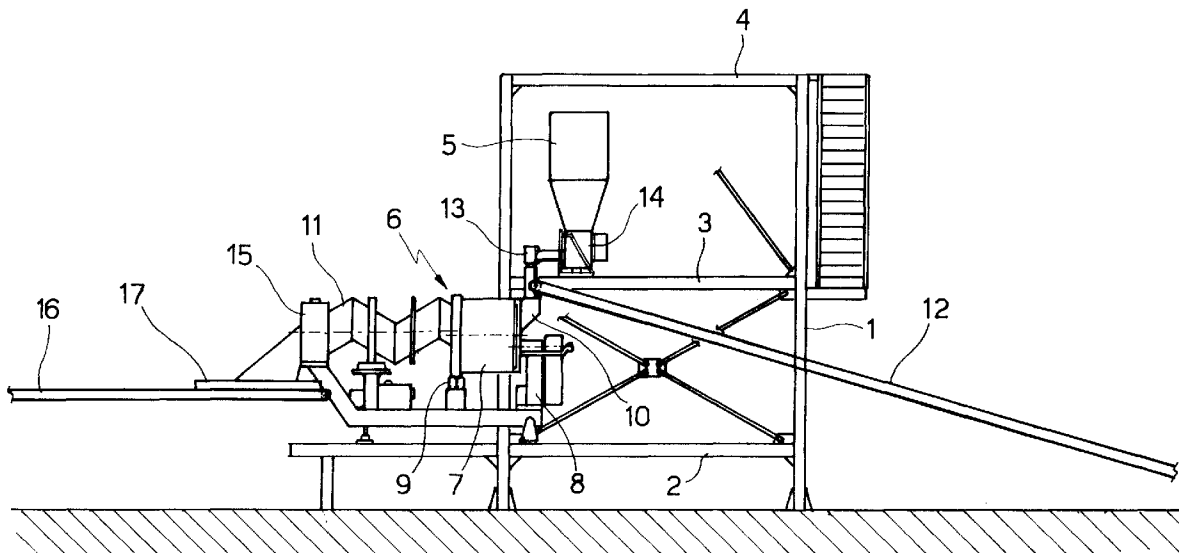

FIG.1

EP 0 916 462 A2

Description

[0001] This invention relates in a totally general manner to ceramic tile manufacture and more particularly to the preparation of materials in powder form which constitute the basic or starting substance for producing said tiles.

[0002] Specifically, the invention relates to a method and the relative implementation means for preparing coloured materials in powder form used in the manufacture of fine porcellainized ceramic stone tiles, single-fired tiles and other similar tiles.

[0003] As is well known, said basic or starting substances consist of masses of granules of virtually uniform dimensions and of a specific coloration, so that single-colour tiles are obtained if granules of a single type are used, whereas multi-colour tiles are obtained if granules of different types are used.

[0004] In the current art, said granules are produced substantially in the following manner:

- a concentrated solution is prepared containing pigments, a ceramic mix and a flocculant,
- grinding said concentrated solution with a series of batch ball mills to obtain a suspension usually known as a concentrated coloured slip,
- transferring the concentrated coloured slip by pumps into a series of storage tanks provided with a stirrer for maintaining the slip in suspension,
- withdrawing the concentrated coloured slip from said tanks and injecting it under pressure, in a predetermined quantity, through a pipe which feeds the neutral or basic slip into an atomization device, or alternatively
- feeding the concentrated coloured slip into a tank in which, by means of a stirrer, it is mixed with neutral slip after which the coloured slip is atomized, and
- storing the atomized material which, as explained, is coloured throughout its entire mass.

[0005] The widespread use of such known methods, known as wet methods, has brought to light various drawbacks, such as:

- excessive plant complexity, with consequent control and maintenance, adjustment and reliability problems,
- excessive plant size,
- need to hold a considerable quantity of atomized product in store for each individual colour,
- need to wash the corresponding plant section each time an atomized product of a different colour is required, and
- relatively high operating cost due to amortization of the plant purchase price and to energy consumption.

[0006] Moreover the final atomized material cost is relatively high because colouring the entire granule mass results in a wastage of pigments and colorants, the cost of which is much higher than that of the other constituent materials of the concentrated coloured slip.

[0007] The main object of this invention is to obviate the aforesaid by the operating system claimed in claims 1 to 4 and the relative implementation means claimed in claims 5 to 12, by which the materials claimed in claims 13 to 19 are obtained.

[0008] In particular, according to the proposed system or method the materials of the invention are obtained by a dry or substantially dry technique, as will be apparent from the ensuing description.

[0009] Generally, the method of the invention provides a mass of neutral material in powder form, ie consisting of granules obtained by a usual atomization or granulation operation such as to obtain granules having a size of the order of 1 mm starting from a slip not containing pigments or other colorants, said granules then being mixed with a metered quantity of fine coloured particles of much smaller size than said granules, the mixing continuing until the outer surface of these latter is completely covered with a continuous layer of said fine particles.

[0010] In a preferred embodiment of the proposed method, said mixing is carried out completely under dry conditions, its duration being protracted until said fine particles have been received, or rather embedded, in the surface layer of the granules, which hence assume the coloration of said particles.

[0011] According to said preferred embodiment the fine particles have a size indicatively between 2 and 300 microns.

[0012] The mixing time depends on the chosen working parameters, such as the type and operating speed of the machinery used, the granule and particle size, and the working temperature.

[0013] In a further embodiment of the proposed method, mixing is carried out substantially under dry conditions, and envisages adding to the granules and fine particles a fluid substance acting as a binder, ie able to cause the fine coloured particles to adhere both to each other and to the outer surface of the granules.

[0014] In this manner coloured granules are obtained each comprising a shell of fine particles which encloses a neutral starting granule.

[0015] In said further embodiment the fine particles have a size indicatively of between 125 and 1000 microns.

[0016] The covering time is less than that in the aforesaid first embodiment.

[0017] The interior or active region of the corresponding machinery is surface-treated or coated such that the binder does not adhere to it.

[0018] According to the invention, water is preferably used as the binder.

[0019] By virtue of the aforesaid technique all the ob-

jects of the invention are attained in that:

- the relative apparatus consists of a mixing unit provided with means for introducing said granules and said fine particles and means for withdrawing the surface-coloured granules, hence it is of little complexity, is simple to control, adjust and maintain, and is also particularly reliable,
- its overall size is very small when compared with the plant used in the wet method described in the introduction,
- the coloured material does not need to be stored in large quantities, as it can be prepared practically at the moment of and in accordance with its requirements, upstream of the production lines, and
- the operating costs are correspondingly relatively low, enhanced by the fact that cleaning or washing operations are not required when passing from one colour to another.

[0020] Moreover the coloured material in powder form obtained by the invention is of low cost in that the most valuable material, ie the colorant, constitutes only a small part of the body of the final granule.

[0021] Finally, it should be noted that from the materials of the invention tiles are obtained, for example of fine porcellainized ceramic stone, the characteristics of which are of the same type as those which characterise the tiles formed from atomized materials prepared in accordance with the known art.

[0022] The operating stages of the proposed method will be more apparent from the ensuing description given with reference to the accompanying drawing, on which Figure 1 shows a preferred embodiment of the mixing apparatus.

[0023] Figure 1 shows a frame 1 having three platforms positioned at different heights and indicated by the reference numerals 2, 3 and 4 starting from the lower platform.

[0024] The upper platform 4 supports an ordered plurality of vessels (not shown) for containing coloured ceramic granules of different colorations, in the form of fine particles in the dry state; the intermediate platform 3 supports a hopper 5 which can be connected at choice to said overlying vessels by a suitable sealed conduit, such as a salient flexible trunk; the lower platform 2 supports a mixer 6.

[0025] This latter comprises a rotatable drum 7 of horizontal axis supported by rollers 9 and rotated, preferably with continuous motion, by a geared motor unit with incorporated variable speed drive. Said drum 7 has a stationary loading mouth and an off-centre discharge mouth from which there extends a tubular body 11, the longitudinal development of which has a zig-zag configuration.

[0026] At said loading mouth 10 there converge a continuously moving motorized conveyor belt 12 the upstream end of which is connected to a usual atomizer

or ceramic granulator, and a pipe 13 connected to the overlying hopper 5 by way of a metering extractor 14 provided with a programmable weigher.

[0027] Said belt 12 provides a constant quantity, per unit of time, of an atomized or granulated ceramic material with a moisture content from 4 to 6% which is of neutral type, ie does not contain pigments or colorants, said metering extractor 14 providing, in the same unit of time, a quantity of pigment of the desired coloration which is a determined proportion of the quantity of atomized or granulated material introduced into the drum 7.

[0028] Said atomized or granulated material is in the form of granules having statistically the same size, of the order of 1 mm, said pigment being in the form of dry fine particles also statistically of the same size, this being between 2 and 1000 microns.

[0029] The order of magnitude of the size of said fine particles varies according to the manner of implementing the method, as described hereinafter.

[0030] The plant, or apparatus, is completed by a stationary collection chamber 15 for the coloured material leaving said body 11, which rotates rigidly with the drum 7, and a continuously operating conveyor belt 16 for withdrawing said coloured material.

[0031] The chamber 15 is provided with a suction unit (not shown) for recovering and recycling the excess fine particles and for removing those suspended in the air. In addition, between the belt 16 and the chamber 15 there is a cowling 17 for guiding the falling material, the belt 16 terminating in a bank of storage tanks (not shown) for storing the powder materials of different coloration.

[0032] In a first embodiment of the method of the invention, said fine pigment particles are embedded under dry conditions into the surface layer of the granules of neutral ceramic material, said embedding stage proceeding until said granules have been completely covered with pigment.

[0033] Using neutral starting granules with the stated diameter of the order of 1 mm, the required results are obtained by using fine pigment particles with a size of between 2 and 300 microns.

[0034] In a further embodiment, a binder is added to said granules and to said particles, its purpose being to cause the said fine pigment particles to adhere both to each other and to the outer surface of the granules, so that on leaving the plant these latter are enclosed by a thin coloured shell.

[0035] For this operation, water has proved to be a convenient binder.

[0036] In this case the fine pigment particles have a size of between 125 and 1000 microns.

[0037] The plant in this case comprises a vessel with relative adjustable dispenser, for containing and feeding said water.

[0038] In addition, said drum 7 and said body 11 are preferably coated with an anti-adhesion material, heat-

ing means such as a hot air blower being associated with the collection chamber 15 to remove the excess water.

[0039] The invention is not limited to that illustrated and described, but comprises all improvements and modifications implemented within the context of the ensuing claims.

Claims

1. A method for preparing coloured materials in powder form for ceramic tile manufacture, characterised by feeding a mixing device with a mass of atomized or granulated ceramic material the granules of which are of statistically equal size and do not contain added colorants, and a metered quantity of fine coloured particles of much smaller size than said granules, then mixing the entirety until the outer surface of said granules is completely covered by said fine coloured particles. 5
2. A method as claimed in claim 1, characterised in that said fine particles remain embedded in the outer surface layer of said granules. 10
3. A method as claimed in claim 1, characterised in that a suitable binder is fed to the mixing device to facilitate adhesion of the fine particles both to each other and to the outer surface of said granules. 15
4. A method as claimed in claim 3, characterised in that said binder is water. 20
5. An apparatus for implementing the method claimed in claims 1 to 4, characterised by comprising a mixing unit (6), with the inlet of which there are associated loading means (12) for feeding said granules, and loading means (5) for the metered feeding of said particles, and with the outlet of which there are associated withdrawal means (16) terminating in storage means. 25
6. An apparatus as claimed in claim 5, characterised in that said loading means for said granules of atomized ceramic material or granulate comprise a continuously operating belt conveyor (12) of adjustable speed. 30
7. An apparatus as claimed in claim 5, characterised in that said loading means for said particles comprise a vessel connected to the inlet of said mixing unit via a continuous cycle metering extractor (14) provided with programmable weighing means. 35
8. An apparatus as claimed in claim 5, characterised in that said mixing unit comprises a rotary loading drum (7) of virtually horizontal axis which is rotated with continuous motion by a variable speed drive (8), and has an off-centre discharge mouth to which there is connected, in such a manner as to rotate rigidly with said drum, a tubular body (11) of zig-zag longitudinal development. 40
9. An apparatus as claimed in claim 8, characterised in that with said mixing unit there is associated a vessel for the metered introduction of a binder, such as water. 45
10. An apparatus as claimed in claim 8, characterised in that the operating members and the interior of said mixing unit are treated or coated with an anti-adhesion material. 50
11. An apparatus as claimed in claim 8, characterised in that between said mixing unit and said withdrawal means there are interposed means, such as a hot air blower, for removing excess water from the coloured material leaving the mixing unit. 55
12. An apparatus as claimed in claim 8, characterised in that said withdrawal means (16) comprise a belt conveyor driven with continuous motion by an adjustable speed drive, with its upstream end there being associated a suction unit for recovering and recycling the excess fine particles.
13. Coloured materials in powder form for ceramic tile manufacture, typically fine porcellainized ceramic stone tiles, characterised in that each individual coloured granule comprises a core consisting of a ceramic clay granule not containing added colouring pigments, and a continuous coloured coating which completely covers the outer surface of said core.
14. Materials as claimed in claim 13, characterised in that said coloured coating consists of a mass of fine particles of a coloured ceramic pigment.
15. Materials as claimed in claim 14, characterised in that said coloured coating is provided by said fine particles which are embedded into the outer surface layer of said clay granules.
16. Materials as claimed in claim 14, characterised in that said fine particles have a size of between 2 and 300 microns.
17. Materials as claimed in claim 13, characterised in that said coloured coating is provided by a thin shell of fine particles which encloses and covers the clay granule.
18. Materials as claimed in claim 17, characterised in that consistency between said clay granule and said shell of fine particles is provided by a binder,

such as water, which causes said fine particles to adhere both to each other and to the outer surface of said granule.

19. Materials as claimed in claim 17, characterised in that said fine particles have a size of between 125 and 1000 microns. 5

20. Ceramic tiles for flooring and facing, typically fine porcellainized ceramic stone tiles coloured throughout the whole or part of their mass, characterised in that the coloured part of said mass consists of materials in accordance with claims 13 to 19. 10

15

20

25

30

35

40

45

50

55

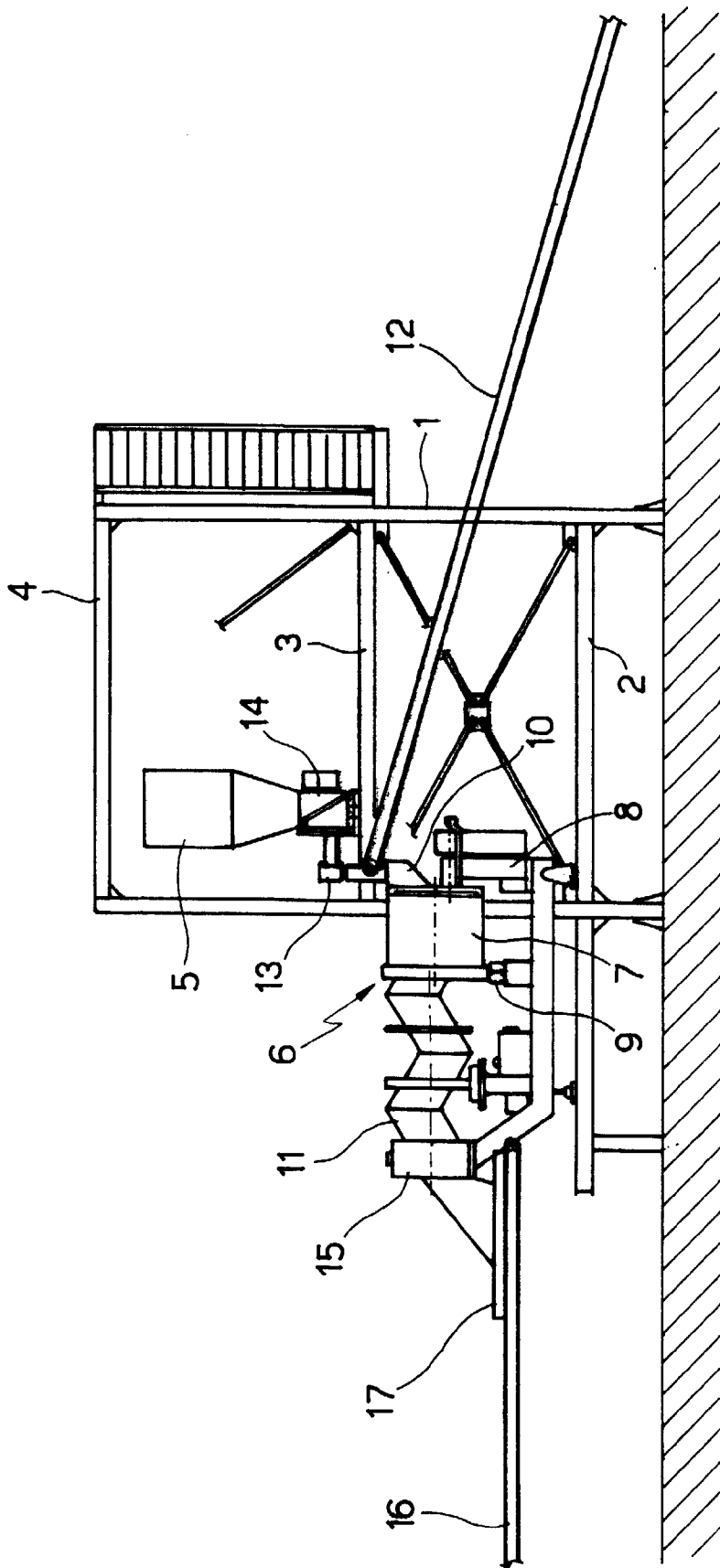

FIG. 1