

(No Model.)

F. H. CLEMENT.

BUZZ PLANER.

No. 354,773.

Patented Dec. 21, 1886.

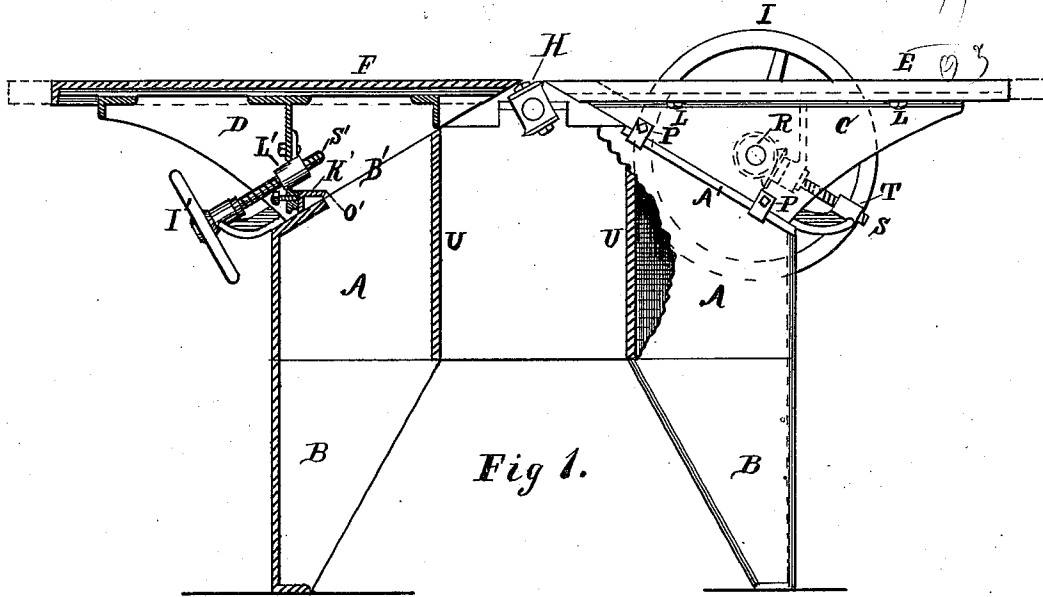

Fig 1.

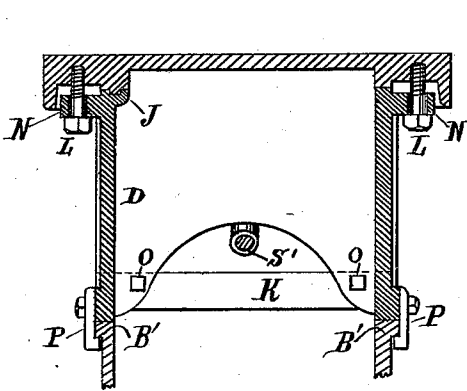

Fig 3.

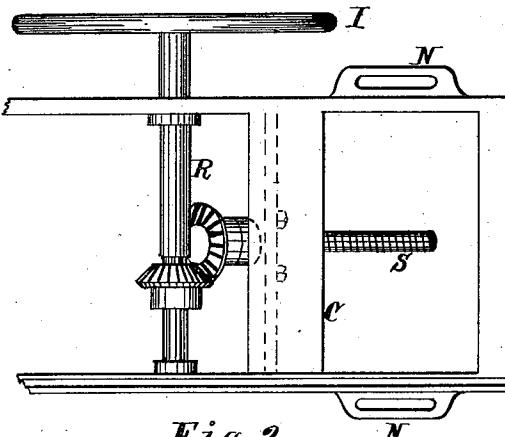

Fig 2.

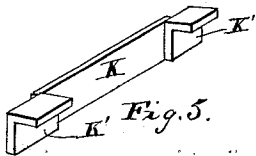

Fig. 5.

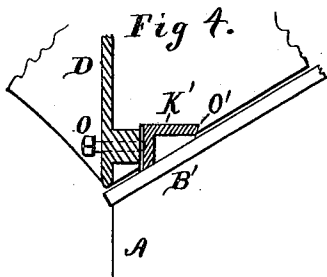

Fig 4.

Witnesses:

J. E. McAlvey  
Geo. B. Selden

Inventor:

Frank H. Clement

# UNITED STATES PATENT OFFICE.

FRANK H. CLEMENT, OF ROCHESTER, NEW YORK.

## BUZZ-PLANER.

SPECIFICATION forming part of Letters Patent No. 354,773, dated December 21, 1886.

Application filed June 13, 1885. Serial No. 168,639. (No model.)

*To all whom it may concern:*

Be it known that I, FRANK H. CLEMENT, a citizen of the United States, residing at Rochester, in the county of Monroe and State of New York, have invented certain new and useful Improvements in Hand or Buzz Planers; and I hereby declare the following to be a full, clear, and exact description of the invention, which will enable others skilled in the art to which it appertains to make and use the same.

My invention relates to that class of wood-planing machines known as "buzz" or "hand" planers, in which the revolving cutter-head runs under a table and the material is fed over it by hand; and it consists, mainly, in a new arrangement of tables and inclined adjusting-ways, and in devices for raising the tables and adjusting the same for different kinds of work.

In the drawings, Figure 1 is a sectional side elevation of my improved machine. Fig. 2 is a plan view of the right-hand adjusting-slide with the table removed. Fig. 3 is a transverse sectional view of the left-hand adjusting slide. Fig. 4 is a detail showing the wedges applied to the table, and Fig. 5 a perspective view of the two wedges and their connecting-bar.

A, Fig. 1, is the bed or frame of my machine, supported on legs B, and having continuous inclined slides or ways A' B' formed thereon, on which triangular-shaped adjusting-slides C and D move. These latter are first fitted to the ways A' B' and then planed level and true with each other on top, after which tables E and F are fitted thereon by means of tongue and groove J, Fig. 3, or some equivalent means, so that the tables can be adjusted horizontally to and from the cutter-head H and held in any required position by clamp-screws L, which may be threaded into the tables and arranged in slots in the lugs N, formed on the adjusting-slides. The outward position of the tables is indicated in dotted lines in Fig. 1.

Clips or gibs P are attached to the slides C and D, so as to prevent side movement or vertical displacement of the slides and tables. The lower extremities of these gibs hook under the ways A' B', as shown in Fig. 3.

The object of the above arrangement of parts is to allow of the separation of the tables

at the cutter-head for the purpose of attaching special knives for molding, tonguing, grooving, &c., and also to allow access to the knives for sharpening; and it will be observed that the inclined movement of the triangular slides C and D always retains the lips of the tables over the cutter at the nearest possible point to the circle of the cut at any depth of chip, the horizontal position of the tables being entirely independent of this adjustment, which is an important point.

There are several advantages in this peculiar arrangement of parts, viz: The triangular adjusting-slides are very rigid, being cast in one piece. The adjusting devices can be all arranged in the adjusting-slides, and need have no connection with the tables directly. The upper faces of the slides can be planed off together after they are fitted to the frame, so that absolute truth of the table-surface can thus be assured without subsequent hand-fitting or adjusting of any kind, it being assumed, of course, that the upper and under surfaces of the tables themselves are first parallel—a comparatively simple matter to accomplish.

I is a hand-wheel quite large in diameter, secured to a cross-shaft, R, having bearings in the slide C. The screw S is also journaled in the latter, and is threaded in a nut, T, secured to the frame A. Bevel or miter gears connect the screw and cross-shaft, as shown.

It will be seen that the wheel I is on the opposite side of the machine from the operator, but is immediately under his right hand, and easy of access at any instant when it becomes necessary to change the cut, which occurs frequently. The advantages of this are, the convenience of the operator, as above mentioned. The strain or pressure required to raise the tables does not fall on the tables themselves, which would be liable to spring, as in other machines. The left-hand triangular slide D is adjusted by an inclined screw and hand-wheel, I', it being seldom necessary to change the position of this table. If desirable, the adjusting devices shown on the right-hand slide could be applied to this also.

Buzz-planers are generally required to be used for glue-jointing—that is, to leave the jointed surfaces a little hollowing. This of course cannot be done on a perfectly-straight table, and for this reason I make provision for

dropping the outer end of the left-hand or finishing table F a trifle.

The outer end of the slide D does not rest on the ways B; but two wedges, K', preferably constructed of angle-iron, are dropped into mortises in the side flanges of the slide, as shown in Figs. 3, 4, and 5, which wedges support the slide and the superincumbent tables upon the ways. I have shown these wedges as connected together by a bar, K; but this is simply a convenience, and is not necessary to the action of the device. It is plain that when the wedges are pushed in or out under the slide D the latter and the table F will rise or fall correspondingly. I make this adjustment by means of set-screws O behind each wedge; and to insure the table always coming level after it has been changed the wedges are fitted to come in contact with shoulders O' on the slide D. When it is desired to drop the outer end of the table F, the screws O are slacked, and the weight of the table and slide will force the wedges back, so as to permit the former to drop sufficiently to produce the hollow joint. To admit of this slight movement the adjusting-screw S is made a little slack in its bearings.

The boxes for the cutter-head H are cast in one piece with the frame A, and partitions or ribs U U are located in said frame at each side of the cutter-head, as shown in Fig. 1. These ribs serve to strengthen the frame, and also form the walls of a chip-spout, down which shavings pass, and to which a suction-pipe from an exhaust-fan may be connected.

I am aware that buzz-planers having both a horizontal and vertical adjustment of the tables are not new; but

What I claim as new, and desire to secure by Letters Patent, is—

1. The combination, in a hand or buzz planer, of a main frame, A, having rigidly secured thereto ways A' B', inclined downward and outward from or nearly from the cutting-point of the head H, intermediate slides, C and D, moving on said ways, and the superincumbent tables E and F, made horizontally adjustable on said slides, substantially as and for the purposes set forth.

2. The combination, in a buzz-planer, of a triangular supporting-slide, C, and its superincumbent table, the adjusting-screw S, cross-shaft R and its hand-wheel, and connecting bevel-gears, whereby a combined vertical and horizontal movement may be given the table by the operator without moving from his post.

3. The combination, in a hand-planer, of the main frame having the incline, the adjustable supporting slide having the recesses in its sides near the lower end, the wedges mounted in said recesses and resting on the incline of the main frame, and the set-screws for adjusting said wedges so as to raise and lower the outer end of the supporting-slide, substantially as described.

4. In a hand-planer, the main frame having the ribs or partitions U U formed upon it on each side of the cutting-head, forming a chute for chips and cuttings, extending from the latter to near the base of the machine, substantially as described.

FRANK H. CLEMENT.

Witnesses:

GEO. B. SELDEN,  
J. E. MCKELVEY.