

J. H. HASTINGS.
PRINTING MACHINE.
APPLICATION FILED JUNE 23, 1911.

1,069,418.

Patented Aug. 5, 1913.

4 SHEETS—SHEET 1.

Fig. 1.

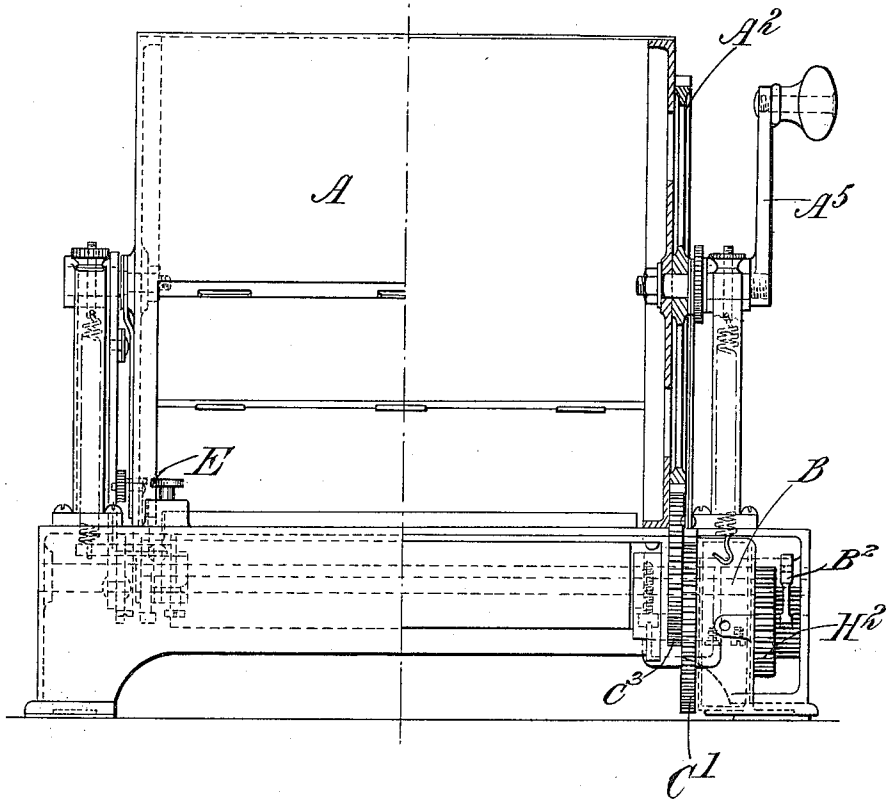

Witnesses
Samuel J. Patton
Byron B. Collings.

Inventor
J. H. Hastings
By Wilkinson, Fisher & Witherpoon
his Attorneys

J. H. HASTINGS.
 PRINTING MACHINE.
 APPLICATION FILED JUNE 23, 1911.

1,069,418.

Patented Aug. 5, 1913.

4 SHEETS-SHEET 2.

Fig. 2.

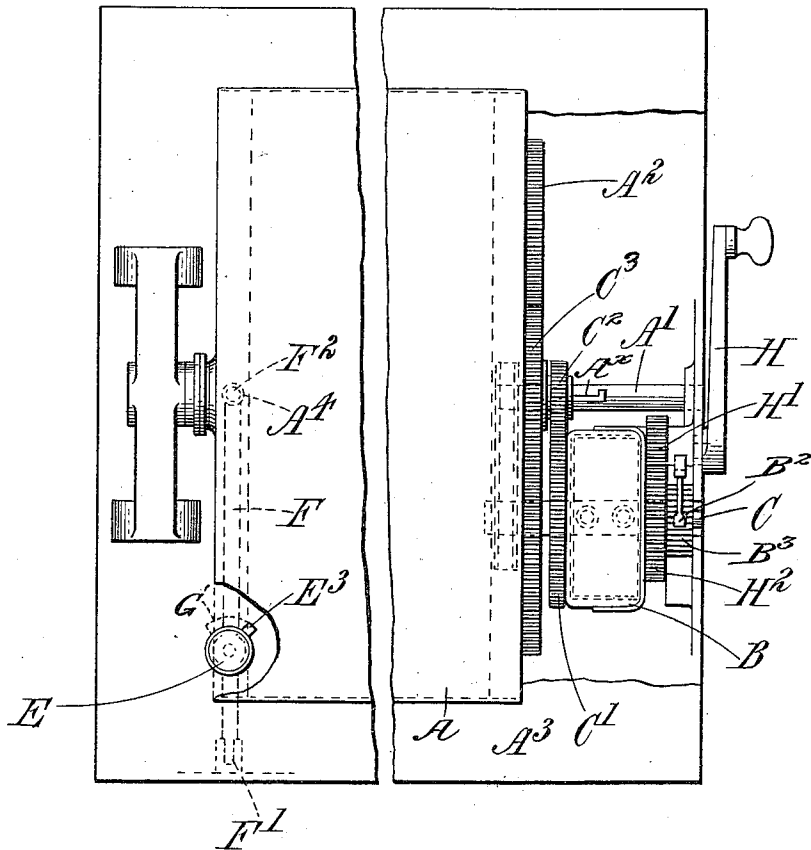

Witnesses
Edward M. ...
Byron B. Collins.

Inventor
J. H. Hastings
 by *William Fisher & Mather*
 his Attorneys

J. H. HASTINGS.
 PRINTING MACHINE.
 APPLICATION FILED JUNE 23, 1911.

1,069,418.

Patented Aug. 5, 1913.

4 SHEETS—SHEET 3.

Fig. 5.

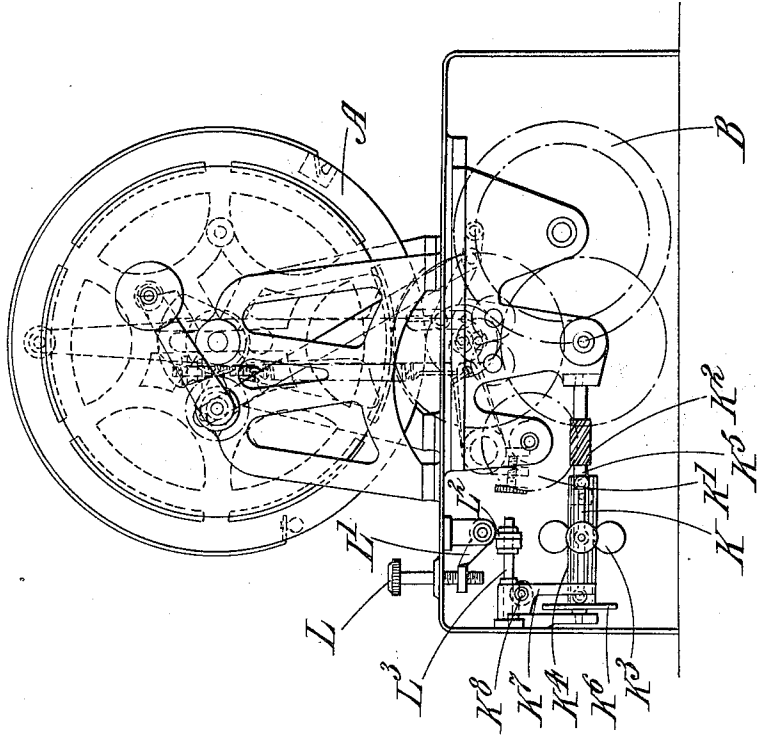
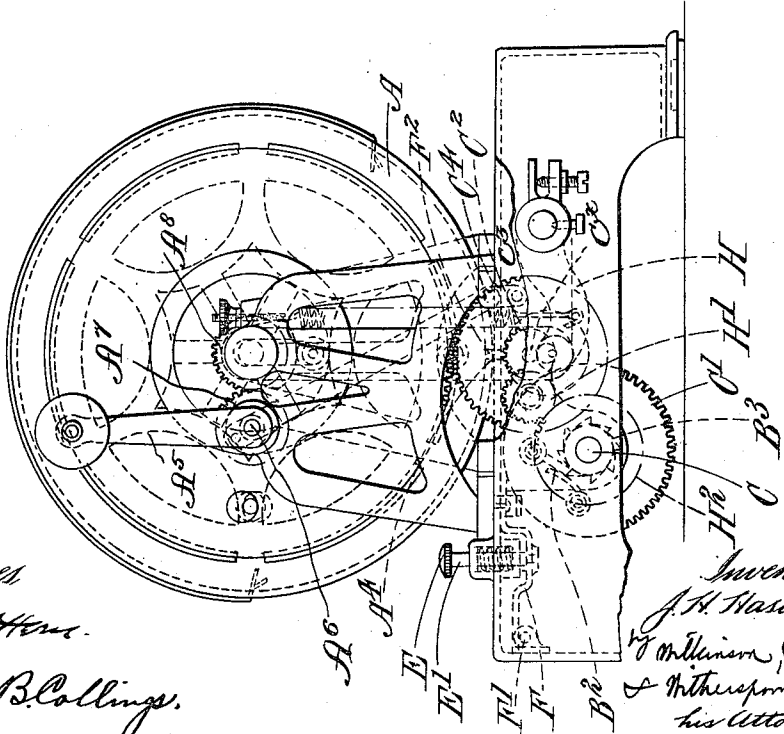

Fig. 3.



Witnesses
[Signature]
 Byron B. Collins.

Inventor
 J. H. Hastings
 T. Williams, Fisher
 & Witherspoon
 his Attorneys

J. H. HASTINGS.
PRINTING MACHINE.
APPLICATION FILED JUNE 23, 1911.

1,069,418.

Patented Aug. 5, 1913.

4 SHEETS—SHEET 4.

Fig. A.

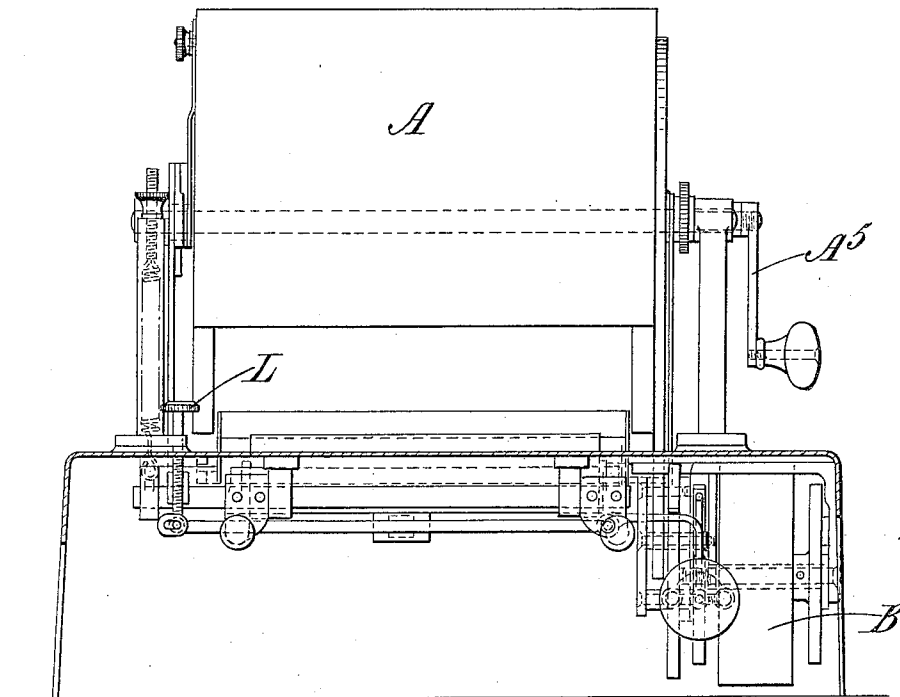

Witnesses
Arthur H. [unclear]
Byron B. Collings.

Inventor
J. H. Hastings
by *William Fisher & Witherspoon,*
his Attorneys

UNITED STATES PATENT OFFICE.

JAMES HAROLD HASTINGS, OF YOKOHAMA, JAPAN.

PRINTING-MACHINE.

1,069,418.

Specification of Letters Patent.

Patented Aug. 5, 1913.

Application filed June 23, 1911. Serial No. 634,920.

To all whom it may concern:

Be it known that I, JAMES HAROLD HASTINGS, a subject of the King of England, residing at Yokohama, Japan, have invented certain new and useful Improvements in Printing-Machines, of which the following is a specification.

This invention relates to printing machines or duplicators of the type in which are provided a printing drum supported on two side frames and an impressing roller situated below the drum to cooperate with the drum in printing. The roller is pulled up by a spring whereby the roller is brought into contact with the surface of the drum on which the printing is performed and pushed down intermittently by cams fitted on the shaft of the drum, when the drum is not engaged in printing. A pinion engaging with a wheel on the drum shaft is connected by a connecting rod to an oscillating piece pivoted inside the machine base, and this, caused to oscillate on rotation of the pinion, feeds the paper.

The object of this invention is to provide such duplicators with self-contained driving mechanism making them also readily convertible to hand-power driving as the occasion demands.

In the accompanying drawings:—Figure 1 is a front elevation partially in section of a duplicator constructed according to this invention. Fig. 2 is a plan thereof, the middle portion being omitted. Fig. 3 is a side elevation of the machine viewed from the right. Fig. 4 is a front elevation of a modification, and Fig. 5 is a side elevation of the same.

Referring to the drawings, A indicates a drum secured to a shaft A^1 , on which is loosely mounted a gear wheel A^2 ; any suitable means, such as an adjustable sliding spline A^x , being provided for locking said wheel A^2 to the shaft A^1 .

A casing B is loosely mounted on a shaft C and incloses a coiled driving spring having its respective ends secured to said casing and shaft. The casing B is rigidly secured to a spur gear C^1 which meshes with a pinion C^2 on a spindle C^x ; a spur gear C^3 being secured to said spindle in mesh with the gear A^2 .

To provide convenient means for winding the driving spring, a gear H^2 is secured to the shaft C in mesh with a pinion H^1 adapted to be rotated by a handle H; a ratchet

wheel B^3 being secured to said shaft C in engagement with a spring-pressed pawl B^2 for locking said shaft against reverse rotation.

A spring-pressed member E is slidably mounted in the machine base and loosely connected to a lever F pivotally supported on said base at F^1 ; the free end of said lever being provided with a projection F^2 adapted to engage a notch in the drum A for locking the latter against rotation. The slidable member E is provided with a projection E^3 adapted to engage a slot G^1 in the machine base when said member E is depressed and slightly turned; thereby providing convenient means for locking the lever F in its depressed position out of engagement with the drum A.

When it is desired to operate the machine by the spring motor, the handle H is turned to wind the driving spring through the intermediary of the gears H^1 and H^2 . The sliding spline A^x is then adjusted to lock the gear wheel A^2 to the shaft A^1 , and the member E depressed and locked to maintain the projection F^2 out of engagement with the drum A. On the other hand, if it be desired to operate the machine by hand, the sliding spline A^x is adjusted to release the gear wheel A^2 from the shaft A^1 , and the drum A turned by the handle A^5 , after the lever F has been depressed to unlock said drum. The handle A^5 is secured to the spindle A^6 of a pinion A^7 meshing with a pinion A^8 on the shaft A^1 .

In the modifications illustrated in Figs. 4 and 5 the speed of the motor is controlled by a centrifugal governor K driven from the gear-train by any convenient means, such as worm wheel K^1 , and worm K^2 . Any increase of speed of revolution of the governor weights K^3 cause the latter to move with their spring arms K^4 along the shaft K^5 . The disk K^6 attached to the arms K^4 is thereby drawn against the brake-pads K^7 pivoted at K^8 thus slowing the motor by frictional effort. The adjusting screw L acting through the arms L^1 , L^2 and rod L^3 controls the position of the brake-disk K^6 at which the contact between it and the brake-pads K^7 occurs and hence also the speed of the motor.

What I claim as my invention and desire to secure by Letters Patent is:—

1. In a duplicator, the combination of a rotatably-mounted shaft, a printing drum

60

65

70

75

80

85

90

95

100

105

110

secured on said shaft and provided with a notch, a lever provided with a projection for lockingly engaging said notch, a sliding member secured to said lever for shifting the latter into unlocked position, a spring engaging said sliding member for yieldingly maintaining said lever in locking position, and means on said sliding member for locking said lever in its unlocked position.

2. In a duplicator, the combination of a rotatably-mounted drum shaft, a printing drum secured thereon and provided with a notch, a lever provided with a projection for lockingly engaging said notch, a sliding member for shifting said lever into unlocked position, a spring engaging said sliding member for yieldingly maintaining said lever in locking position, means on said sliding member for locking said lever in its unlocked position, a gear wheel loosely mounted on said drum shaft, adjustable means for locking said gear wheel on said shaft, a gear train meshing with said gear wheel, a driving spring for actuating said gear train, and manually-operated means for rotating said printing drum independently of said gear train.

In testimony whereof I have signed my name to this specification in the presence of two subscribing witnesses.

JAMES HAROLD HASTINGS.

Witnesses:
C. B. BERNARD,
L. C. SHARMAN.

Copies of this patent may be obtained for five cents each, by addressing the "Commissioner of Patents, Washington, D. C."