

Dec. 11, 1962

A. C. SWANSON  
NAILING MACHINE

3,067,423

Filed Oct. 26, 1960

5 Sheets-Sheet 1

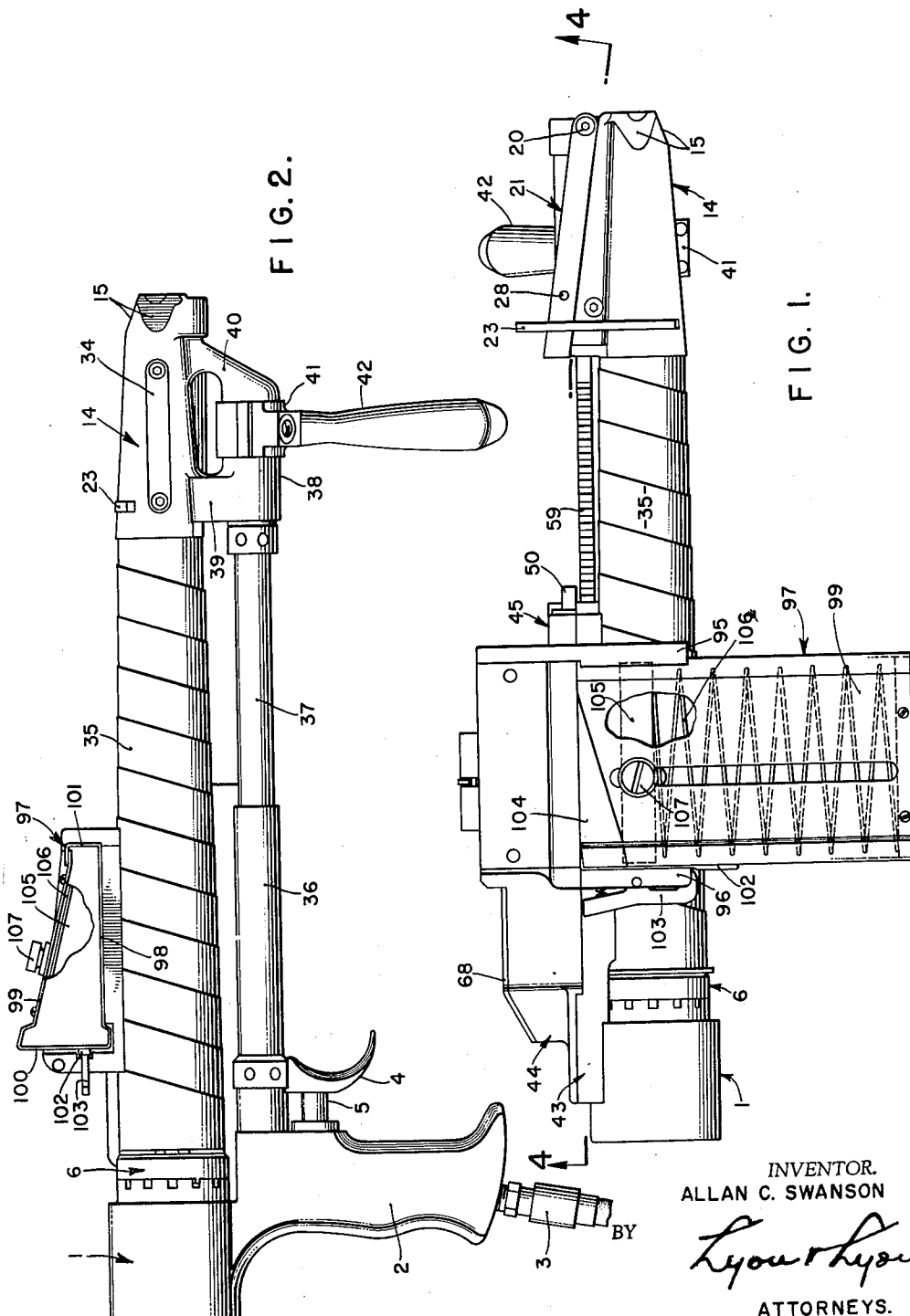

FIG. 2.

FIG. 1.

INVENTOR.  
ALLAN C. SWANSON

BY  
*Lyons & Lyons*  
ATTORNEYS.

Dec. 11, 1962

A. C. SWANSON

3,067,423

NAILING MACHINE

Filed Oct. 26, 1960

5 Sheets-Sheet 2

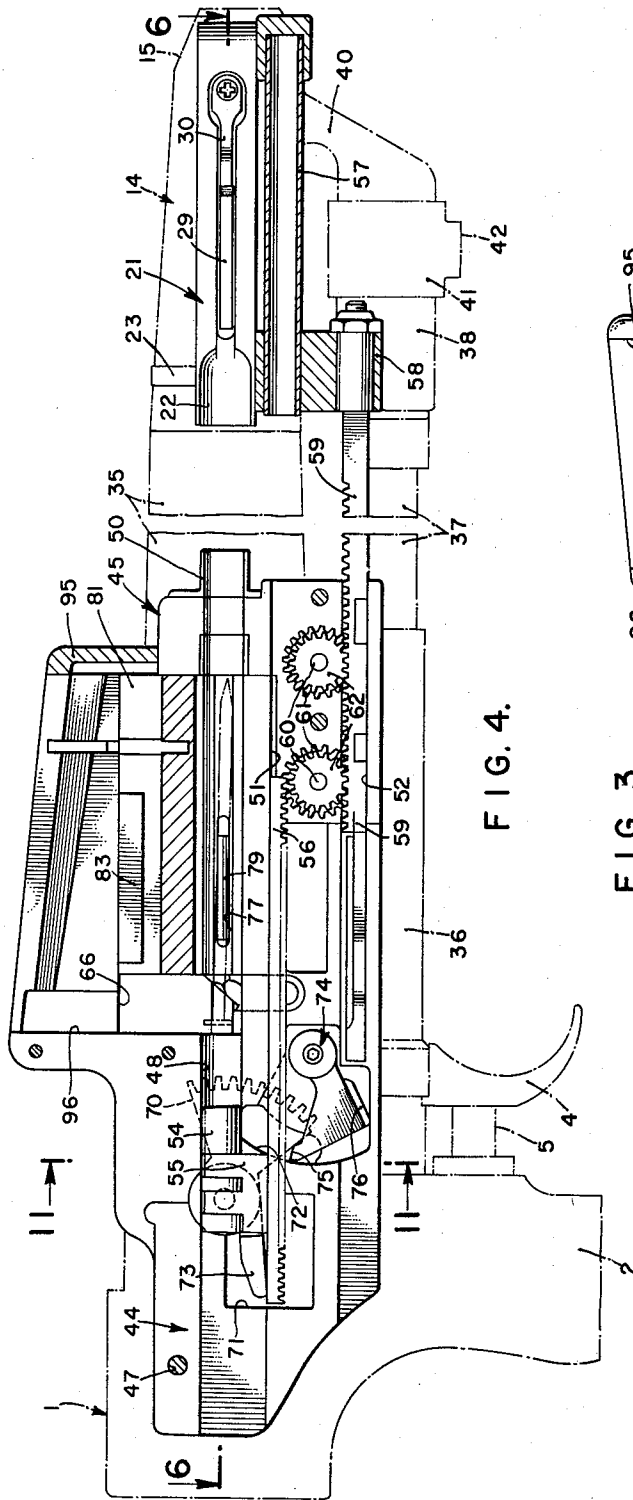

FIG. 4.

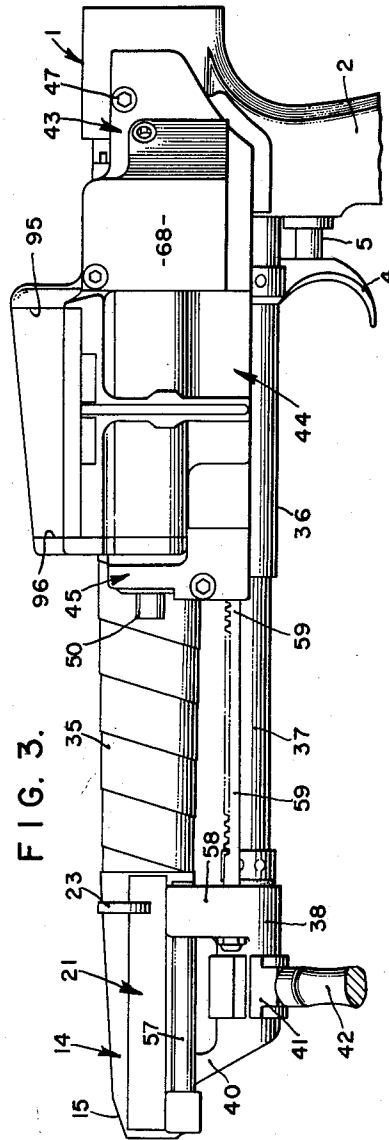

FIG. 3.

INVENTOR.  
ALLAN C. SWANSON

BY

*Lyons & Lyons*

ATTORNEYS.

Dec. 11, 1962

A. C. SWANSON

3,067,423

NAILING MACHINE

Filed Oct. 26, 1960

5 Sheets-Sheet 3

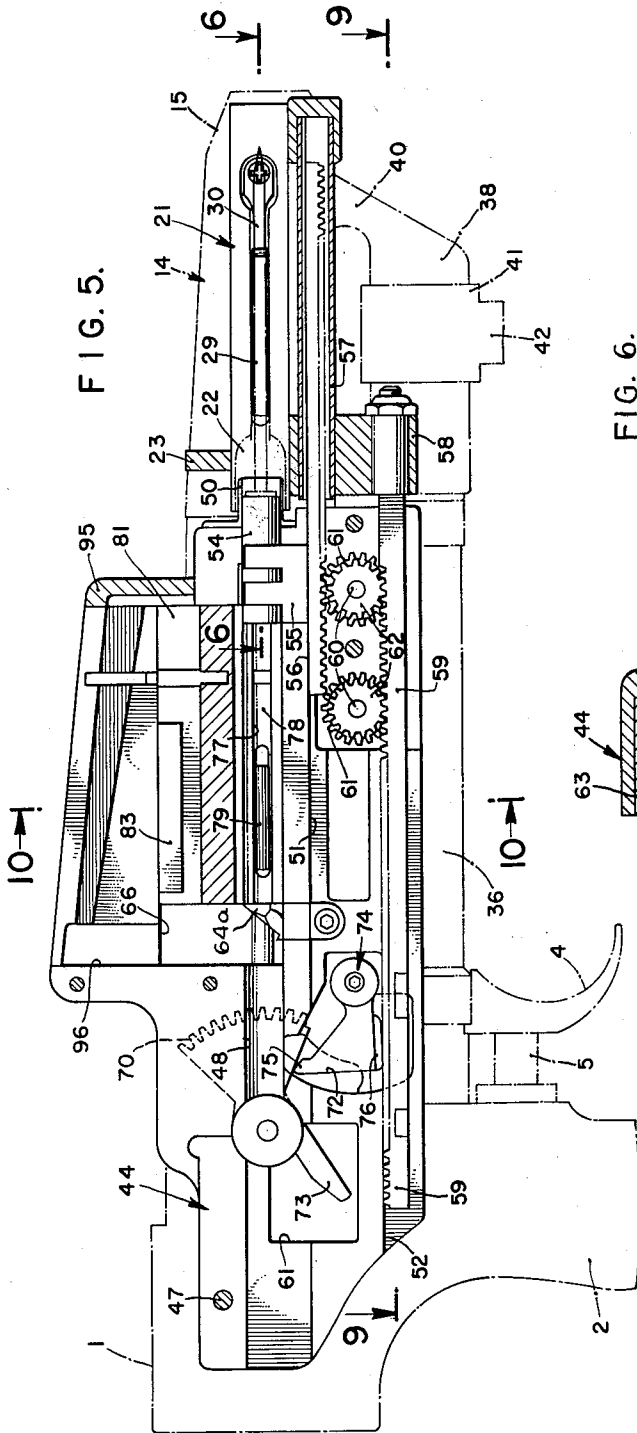

FIG. 5.

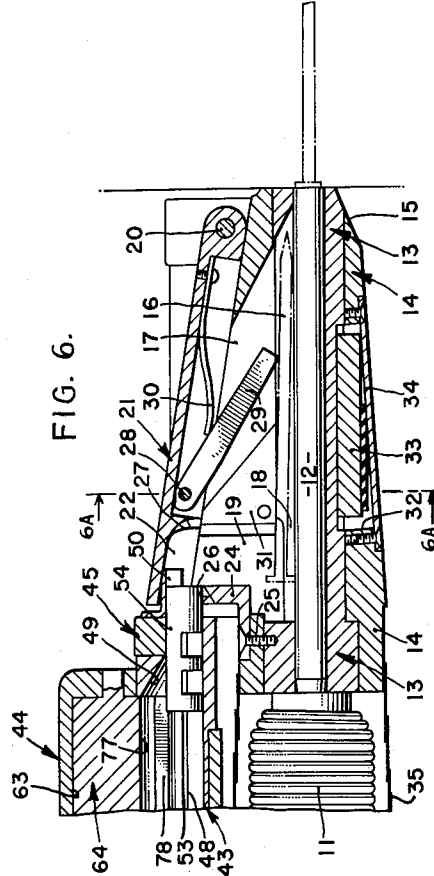

FIG. 6.

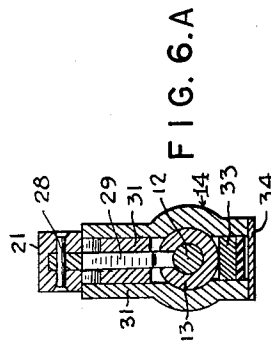

FIG. 6.A

INVENTOR.  
ALLAN C. SWANSON

BY

*Lyons Lyons*

ATTORNEYS.

Dec. 11, 1962

A. C. SWANSON

3,067,423

NAILING MACHINE

Filed Oct. 26, 1960

5 Sheets-Sheet 4

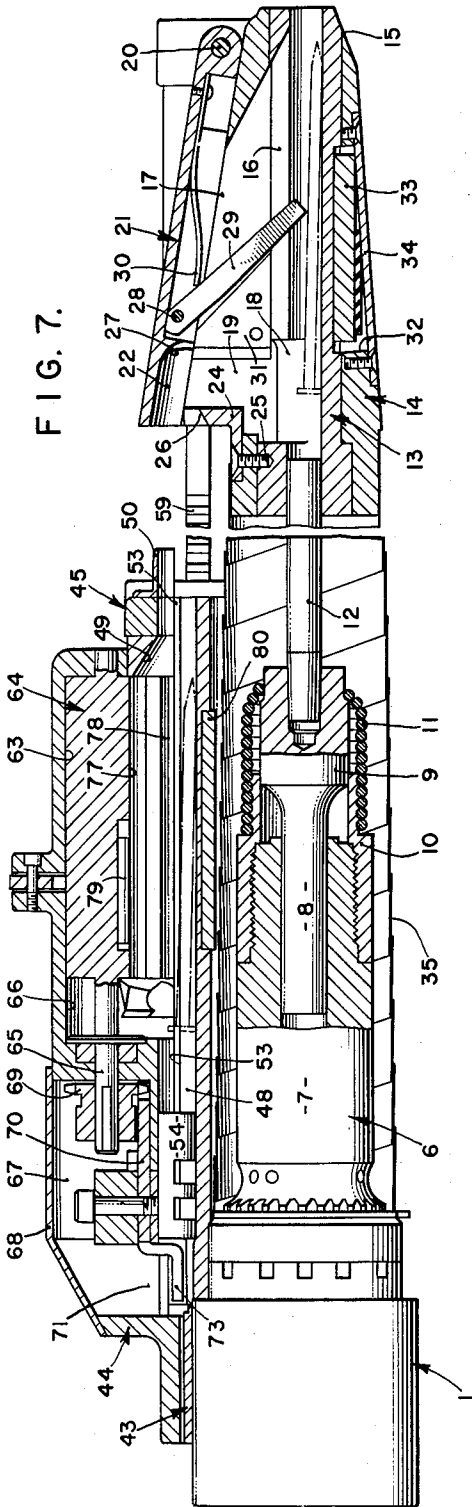

FIG. 7.

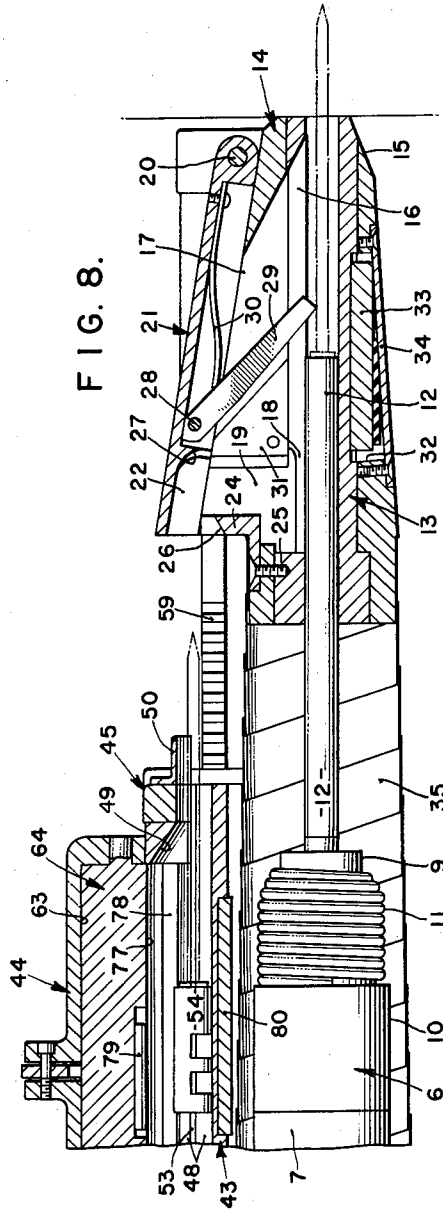

FIG. 8.

INVENTOR.  
ALLAN C. SWANSON

BY

*Lyons & Lyons*

ATTORNEYS.

Dec. 11, 1962

A. C. SWANSON  
NAILING MACHINE

3,067,423

Filed Oct. 26, 1960

5 Sheets-Sheet 5

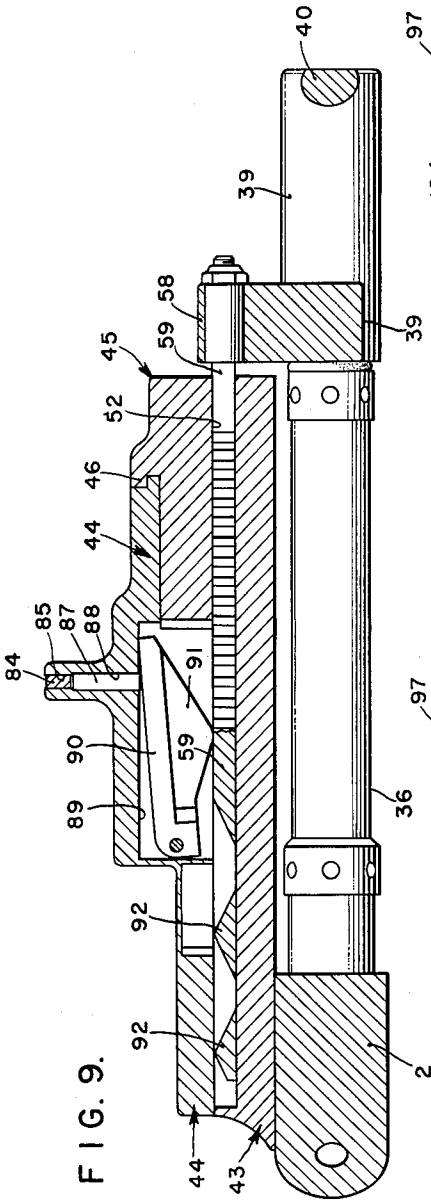

FIG. 9.

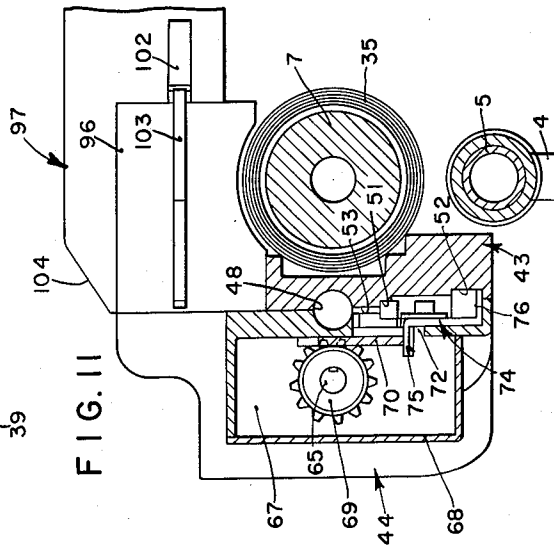

FIG. 11

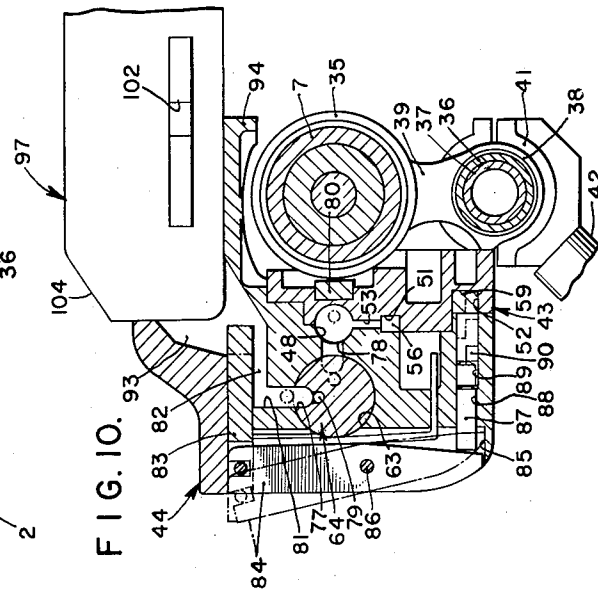

FIG. 10.

INVENTOR.  
ALLAN C. SWANSON

BY

ATTORNEYS.

1

3,067,423

**NAILING MACHINE**

Allan C. Swanson, Sunland, Calif., assignor, by mesne assignments, to Nu-Matic Nailer International Corp., Los Angeles, Calif., a corporation of California  
 Filed Oct. 26, 1960, Ser. No. 65,047  
 4 Claims. (Cl. 1—46)

This invention relates to hand held power nailing machines and included in the objects of this invention, are:

First, to provide a power operated nailing machine which may be held in the operator's hands and directed downwardly, horizontally, or upwardly without affecting its nailing operation.

Second, to provide a hand held power nailing machine wherein novelly and strategically disposed magnet elements insure feed of the nails from a magazine to the discharge chamber to eliminate the effect of gravity on the operation of the machine.

Third, to provide a hand held power operated nailing machine which incorporates a novel nose piece which permits the driving of "toeing" nail's at an angle into studs, rafters, and floor and ceiling joists, and accomplish such operations at a much faster rate than is possible with a hand operated hammer.

Fourth, to provide a hand held power operated nailing machine wherein the major components are readily and quickly disassembled for service, and wherein the nail receiving chamber and the adjacent nail driving chamber are readily accessible in the event jamming occurs.

Fifth, to provide a hand held power operated nailing machine which is particularly rugged and dependable in operation so that jamming, even by an inexperienced operator is minimized.

Sixth, to provide a hand held power operated nailing machine which incorporates a novel nail holding magazine adapted to hold in a compact space a large number of nails.

Seventh, to provide a hand held power operated nailing machine which is capable of handling without adjustment a wide range of nails merely by substituting different magazines.

With the above and other objects in view as may appear hereinafter, reference is directed to the accompanying drawings, in which:

FIGURE 1 is a top plan view of the nailing machine.

FIGURE 2 is a side elevational view thereof.

FIGURE 3 is a side elevational view thereof taken from the side opposite from FIGURE 2 with the pistol grip shown fragmentarily.

FIGURE 4 is an enlarged sectional view with portions of elevation, the view being taken substantially along lines 4—4 of FIGURE 1 with portions forwardly of the plane in which the view is taken shown in broken outline and with the parts in a position wherein the machine is in its extended position.

FIGURE 5 is a similar sectional view with portions of elevation showing the parts of the machine in their retracted position.

FIGURE 6 is a fragmentary sectional view through 6—6 of FIGURE 5, showing particularly the nose portion of the machine as the parts appear when the nailing operation is completed.

FIGURE 6A is a sectional view through 6A—6A of FIGURE 6, showing the nose piece and internal parts but omitting the external bracket structure.

FIGURE 7 is a longitudinal sectional view taken substantially in the same plane as FIGURE 6 with the parts as shown in position for receiving a nail in the nailing barrel; this being the extended position of the machine corresponding to FIGURES 1 and 2.

FIGURE 8 is a fragmentary sectional view taken sub-

2

stantially in the same plane as FIGURES 6 and 7, showing the parts of the machine when the nail has been partially driven.

FIGURE 9 is a longitudinal sectional view taken through 9—9 of FIGURE 5.

FIGURE 10 is a transverse sectional view taken through 10—10 of FIGURE 5.

FIGURE 11 is a transverse sectional view taken through 11—11 of FIGURE 4.

The nailing machine includes a substantially cylindrical breech housing 1. Extending from the under side of the breech housing and offset forwardly thereof is a pistol grip 2. The extended end of the pistol grip 2 is provided with an air intake fitting 3. Located forwardly of the pistol grip 3 is a trigger 4 connected by a rearwardly extending trigger shaft 5 to an air valve (not shown) within the pistol grip 2. Air passages (not shown) lead from the intake fitting 3 through the air valve to the breech housing 1. Suitably secured to the forward end of the breech housing 1 is a conventional air hammer 6 which includes a cylinder 7 in which reciprocates a plunger 8 having an enlarged head 9 projecting forwardly of the cylinder 7. The head 9 reciprocates within a cap sleeve 10. A spring 11 normally holds the plunger 8 in a retracted position relative to the cylinder 7 and cap sleeve 10.

Secured in the head 9 is a hammer shaft or pin 12 which projects forwardly into a nail receiving barrel 13 which is fitted within a nose housing 14. The barrel 13 is in the form of a sleeve or liner fitting within a bore extending through the nose housing 14. The rear end of the barrel 13 is enlarged so as to fit within a counter-bore provided in the nose housing to restrain the barrel against axial displacement. The barrel 13 extends to the forward or operating end of the nose housing 14 and three sides of the nose housing and tip as well as the tip portion of the barrel 13 are beveled as indicated by 15.

One side of the barrel 13 is provided with a nail receiving slot 16 and the corresponding side of the nose housing is provided with a nail receiving chamber 17 in registry with the side slot 16. The rearward portions of the side slot 16 and nail receiving chamber 17 are laterally enlarged to form nail head receiving cavities 18 and 19, respectively.

The nail receiving chamber extends laterally and intersects the side of the nose housing. This side of the nose housing converges forwardly towards the bore of the barrel 13. Near the forward end of the nose housing is a pivot pin 20 which pivotally supports a cover bar 21. The cover bar extends rearwardly over the nail receiving chamber and in the region of the head receiving cavity 19 is provided with a rearwardly opened entrance cavity 22. Pivotaly secured to the upper side of the nose housing 14 opposite from the cover bar 21 is a latch lever 23 which is adapted to hook over and hold the cover bar 21 in place, but which may be readily lifted to release the cover bar for access to the nail receiving chamber 17 and side slot 16.

The rear end of the nail receiving cavity 19 is closed by a small guide bracket 24 which is held in place by a screw 25. The screw 25 also serves to secure the barrel 13 in the nose housing 14.

The guide bracket 24 projects laterally toward the cover bar 21 and terminates in a bevelled end 26 which forms with the cover bar 21 an entrance opening into which the nails are inserted.

At the forward or inner end of the entrance cavity 22, there is formed a deflector rib 27. Pivotaly mounted forwardly of the rib 27, on a pivot pin 28, is a deflector lever 29 which converges forwardly into the bore of the nail receiving barrel 13. The deflector lever is backed.

by a leaf spring 30 which urges the free or forward end of the deflector lever into the barrel bore.

Opposite walls of the nail receiving chamber 17, immediately forward of the nail receiving cavity 19, are provided with a pair of opposed spaced plate magnet 31. At the side of the barrel 13, opposite from the side slot 16, the wall thickness of the barrel is reduced. In this region, the nose housing 14 is provided with a slot 32 which receives a bar magnet 33. The barrel 13 and nose housing 14 are formed of non-magnetic material so that the plate magnet 31 and bar magnet 33 may function to guide and restrain nails as will be described in more detail hereinafter. A suitable cover plate 34 fits over the slot 32.

The region between the breech housing 1 and nose housing 14 is provided with longitudinally expansible and contractible shield 35 which encloses the pneumatic hammer 66. The shield may be formed of a helically coiled strip formed of spring steel.

Below the shield 35 and above the trigger 4 is a guide tube 36 which extends forwardly from the pistol grip 2. Slidably mounted in the guide tube 36 is a guide bar 37, the forward end of which is secured to a bracket 38 connected by forward and rearward webs 39 and 40 to the underside of the nose housing 14. Between the webs 39 and 40 the bracket 38 is cylindrical and separated from the nose housing by a slot so as to receive a clamp collar 41 capable of angular adjustment. A forward hand grip 42 extends from the clamp collar 41.

Secured to the side of the breech housing 1 corresponding to the side of the nose housing 14 having the nail receiving chamber 17 is an inner housing member 43 which extends forwardly parallel to the axis of the pneumatic hammer 6. Adjacent to but clearing the helical shield 35, the inner housing 43 is covered by a rearwardly disposed outer housing 44 and a forwardly disposed outer housing 45. The three housings are complementary. The forward outer housing is secured to the forward portion of the inner housing 43 and is connected to the rearward outer housing 44 by a hook and tongue means 46. The rearward end of the outer housing 44 is secured to the inner housing 43 preferably by a single screw 47 so that the rearward outer housing 44 may be readily removed.

The rearward outer housing 44 and inner housing 43 define therebetween a feed plunger bore 48 which extends parallel with the axis of the pneumatic chamber 46. At its forward end, the inner housing 43 is laterally enlarged to form a nail discharge opening 49 continuing from the feed plunger bore 48. A telescoping tip 50 continues from the nail discharge opening 49 and is adapted to enter the entrance cavity 22.

The three housings 43, 44 and 45 also define therebetween an upper rack guide bore 51 and a lower rack guide bore 52 which are square in cross-section. The upper rack guide bore 51 is connected by a slot 53 with the feed plunger bore 48. Slidably mounted in the feed plunger bore 48 is a feed plunger 54 which is connected to a web 55, that extends through the slot 53 and is secured to an upper rack 56 slidably mounted in the upper rack guide bore 51.

As will be brought out hereinafter, the upper rack is caused at times to extend forwardly from the housings 43, 44 and 45. In order to protect the upper rack when extended, the nose housing 44 is provided with a guard tube 57 supported at its ends by collars formed integrally with the nose housing 14. Secured to the nose housing 14 below the rearward collar 58 is a lower rack 59 which extends rearwardly therefrom into the lower rack guide bore 52. Located between the inner housing 43 and forward outer housing 45 and also between the upper and lower rack guide bores 51 and 52 are two parallel shafts 60, each of which carries a pair of pinion gears 61 and 62 of slightly different size. The larger pinion gears 61 engages the upper rack 56 and the slightly

smaller pinion gears 62 engage the lower rack 59 as best shown in FIGURES 4 and 5. The pinion gears 61 and 62 are joined together so that the racks are forced to move in opposite directions.

Journalled in the rearward outer housing 44 outwardly from and parallel to the feed plunger bore 48 is a feed drum bore 63 which journals a feed drum 64, a stem 65 extends rearwardly from the feed drum 64 and forms with the bore 63 an annular nail head clearance channel 66. The stem 65 extends rearwardly from the feed drum bore 63 through a wall and into a gear chamber 67 in the form of a recess formed in the rearward outer housing 44 and covered by a cover plate 68. The rearward end of the shaft or stem 65 receives a pinion gear 69. Pivotaly mounted in the gear chamber 67 is a quadrant gear 70 engageable with the pinion gear 69. The rearward outer housing 44 is provided with spaced clearance cavities 71 and 72 which extend into the inner housing 43 and intersect the upper and lower rack guide bores 51 and 52.

The quadrant gear 70 is provided with a lever arm 73 having an offset end which extends through the slot 71 in position for engagement by the upper rack 56 when this rack moves rearwardly in its guide bore 51.

Pivotaly mounted within the cavity 72 is a lever member 74 having an offset lug 75 which extends into the gear chamber 67 for engagement with the quadrant gear 70. The lever member 74 is also provided with a second offset lug 76 positioned for engagement by the lower rack 59 when it moves rearwardly in its rack guide bore 52.

The feed drum 63 is provided with a longitudinal groove 77 dimensioned to receive the shank of a nail. The feed drum bore 63 communicates by a short delivery passage 78 with the feed plunger bore 48. The head clearance channel 66 also intersects the feed plunger bore 48.

A bar magnet 79 is located in the base of the groove 77 and another bar magnet 80 is located in the wall of the inner housing 43 behind the feed plunger bore 48 as shown best in FIGURES 7 and 10. The housings 43, 44 and 45 are formed of non-magnetic material.

The quadrant gear 70 and pinion gear 69 are adapted to oscillate the feed drum 64 approximately 90°. The rearward outer housing 44 is provided with a vertical nail supply passage 81 which communicates with the feed drum bore 63 at approximately right angles to the delivery passage 78. The nail supply passage 81, in turn, intersects a horizontally disposed nail alignment passage 82, the alignment passage 82 is thus parallel with and above the nail delivery passage 78.

Mounted for reciprocation adjacent the upper or roof side of the alignment passage 82 is metering plunger bar 83, the metering plunger bar 83 is reciprocated by a lever 84 which extends downwardly in a slot 85 to the underside of the rearward outer housing 44 as best shown in FIGURE 10. The lever 84 is pivoted intermediate its ends on a pivot pin 86. The lower end of the lever 84 engages a connecting pin 87 movable in a bore 88 which intersects the slot 89. The slot 89 in turn intersects and is parallel with the lower rack guide bore 52. Pivotaly mounted in the slot 89 is a cam lever 90 having a cam lug 91 which projects into the lower rack guide bore 52. The rearward end of the lower rack 59 is provided with a pair of cam lugs 92 separated by notches so arranged as to engage the cam lug 91 and reciprocate the metering plunger bar 83 two times for each backward travel of the lower rack.

The nail alignment passage 82 opens into a nail supply chamber 93, the lower wall of the nail supply chamber slopes downwardly toward the metering plunger bar 83 so that nail shanks may move downwardly and under the metering plunger bar 83. Extending from the lower side of the nail supply chamber 93 is a shelf 94 which overlies the pneumatic hammer 6 and its shield 35. The shelf 94 is provided with forward and rearward end walls 95 and 96.

A nail magazine 97 is adapted to fit on the shelf 94 between the end walls 95 and 96. The nail magazine 97 may be formed of a sheet material and comprises a bottom

wall 98 and a top wall 99. These walls are joined by a relatively wide side wall 100 and a relatively narrow side wall 101 so that the magazine 97 is trapezoidal in cross section. The side walls 100 and 101 are proportioned so that a large number of nails may be stacked therein with their heads adjacent the larger side wall 100.

The wide side 100 of the magazine is provided with a catch element 102 which is adapted to be engaged by a lever 103 pivotally mounted in a slot provided in the end wall 96. The other end wall 95 is provided with a flange which overlies the narrower wall 101 of the magazine. The top wall 99 of the magazine at the discharge end thereof is provided with a downwardly sloping portion 104 so as to direct the nails into the nail supply chamber 93. The magazine 97 when fitted on the shelf 94 between the end walls 95 and 96 extends horizontally and laterally beyond the pneumatic hammer 6 and its helical shield 35, as shown best in FIGURE 1. The extended end of the magazine is closed, and fitted within the magazine is a plunger 105 which is urged toward the discharge end of the magazine by a spring 106. The upper top wall 99 is provided with a longitudinal slot which receives a handle 107 attached to the plunger 105 so that the plunger may be manually retracted in opposition to the spring 106.

Operation of the nailing machine is as follows: In order to relate the various parts of the machine to each other, the machine has been described as occupying a horizontal position, that is, with the axis of the pneumatic hammer 6 in a horizontal position and the magazine 97 also in a horizontal position. In practice, however, the nailing machine may be held in any position, that is, it may be directed upwardly or downwardly or held in various angular positions.

The breech housing 1, housings 43, 44, and 45 form with the grip 2, air hammer 6, hammer shaft 12 and associated parts a breech assembly. The nose housing 14, barrel 13, and associated parts form a nose assembly. The nose assembly is manually movable between a forward or extended position and a rearward or retracted position. This reciprocating movement is utilized to transfer nails from the magazine 97 to the barrel 13 and to move the hammer shaft 12 in the barrel 13 for engagement with a nail therein.

Nails are urged from the magazine 97 by the plunger 105, backed by the spring 106, into the nail supply chamber 93. Here they are worked by reciprocation of the metering bar 83 into an essentially parallel and sequential relationship in the alignment passage 82 for delivery to the supply passage 81 for presentation one-at-a-time to the feed drum 64.

When the nose assembly is in its fully forward or extended position, as shown in FIGURE 7, the machine is in its normal or rest condition, and the feed drum occupies the dotted line position shown in FIGURE 10 which is displaced 90° clockwise from the solid line position shown therein. When the nose assembly is moved to its fully rearward or retracted position, the last portion of this movement causes the lower rack 59, acting through the lever 74, segmental gear 70, and pinion gear 69, to turn the feed drum counterclockwise from a position of registry with the slot 78 to the position shown in FIGURE 10, so as to receive a nail.

When the nose assembly is again returned to its extended position, the final portion of this forward movement causes the rack 56, acting through the lever 73, segmental gear 70, and pinion gear 90, to turn the feed drum 90° clockwise from the position shown in FIGURE 10 to deliver a nail to the slot 78. The head end of the nail is deflected by a cam 64a into the feed plunger bore 48 of the feed plunger 54. The feed plunger 54, it will be noted, occupies a rearward position when the nose assembly is extended. Movement of the nail into the feed plunger bore 48 is aided by the magnet 80 and also by the deflector 49.

When the nose assembly is again moved toward its re-

tracted position, the feed plunger drives the nail forwardly into the entrance cavity 22 of the nose assembly for deflection by the deflector lever 29 toward the bore of the barrel 13. However, when the nose assembly is retracted, the hammer shaft 12 occupies the bore of the barrel 13 so that the point of the nail passes under the deflector lever 29 and is yieldably held against the side hammer shaft 12 until the hammer shaft is withdrawn.

When the nose assembly is again extended, the hammer shaft 12 is withdrawn from the bore of the barrel 13, permitting the nail to be deflected therein by the lever 29. The magnet 33 aids in maintaining the nail in place until engaged by the hammer shaft when the nose assembly is again retracted.

The various magnets tend to nullify the effect of gravity on the nail as it moves from the magazine through the nailing machine so that the nailing machine may be operated in any position, that is, the machine may be used to drive nails upwardly into the ceiling or downwardly into the floor and by reason of the bevelled faces 15, it will be observed that the nose of the machine may be placed angularly with respect to a frame member so that a nail may be driven at an angle therein. This is particularly useful for the purpose of fastening the upper and lower ends of studding in place as well as in nailing floor joist and ceiling joist in place.

It should be observed that the pneumatic hammer 6 is per se conventional and that its function is merely to reciprocate the hammer shaft 12. It is therefore obvious that an electric or solenoid operated hammer may be substituted for the pneumatic hammer.

It also will be apparent that the machine is capable of accepting nails varying from a thickness barely clearing the space available in the alignment passage 82 to nails having a diameter slightly greater than one-half this size. Also the machine will accept nails of various lengths limited in maximum size to the width of the magazine 97. A different magazine may be used for nails of different size so that by providing interchangeable magazines the machine may be quickly converted from joist and studding operations to floor, ceiling or roof operations which may require nails of different size.

In practice, the machine has been found to be remarkably immune to jamming. However, should bent nails or otherwise inferior nails enter the machine, it should be observed that the magazine may be quickly removed, that the outer housing may also be quickly removed by removal of single screw 47 which provides access to the feed plunger bore 48 and that the cover bar 21 may be readily lifted to provide access to the nail receiving chamber 17.

While a particular embodiment of this invention has been shown and described, it is not intended to limit the same to the exact details of the construction set forth, and it embraces such changes, modifications, and equivalents of the parts and their formation and arrangement as come within the purview of the appended claims.

I claim:

1. A nailing machine, comprising: a breech structure including a nail driving means terminating in a nail driving pin; a nail feeding structure secured to one side of said breech structure, and including means defining a nail feeding bore terminating in a discharge end, and a pair of rack guide bores, pinion elements between said guide bores, racks engageable with said pinion elements for reciprocating in opposite directions, and a feed plunger reciprocable in said feeding bore and connected with one of said racks; a nose structure having a guide bore adapted to receive said driving means, and a nail transfer chamber at one side of and communicating with said guide bore, said transfer chamber having an entrance adapted to receive nails from said feeding bore, and means for attachment to one of said racks; and means connecting said breech and nose structures for limited movement to and from each other thereby to move said

nail driving pin into engagement with a nail in said drive bore, to move the discharge end of said nail feeding bore into registry with the entrance of said nail transfer chamber, and to reciprocate said racks and feed a nail through said nail feeding bore.

2. In a nailing machine: a nail feeding structure defining in series relation, a nail receiving chamber, a nail aligning passage, a drum cavity and a nail feeding bore; said structure also defining a pair of rack guiding bores parallel to said feeding bore; said structure also including reciprocable means movable in said aligning passage to dispose nails in parallel relation, a drum rotatable in said drum cavity to receive nails in sequence from said nail aligning passage and deliver nails to said nail feeding bore, pinion gears disposed between said rack bores, racks engageable with said pinion gears and movable in opposite directions in said rack bores, means engageable by said racks to operate said reciprocable means and said drum, and a plunger connected with one of said racks and movable in said nail feeding bore to propel nails in sequence along said bore.

3. A nailing machine, comprising: a nail feeding structure defining in series relation; nail receiving chamber, a nail aligning passage, a drum cavity and a nail feeding bore; said structure also defining a pair of rack guiding bores parallel to said feeding bore; said structure also including reciprocable means movable in said aligning passage to dispose nails in parallel relation, a drum rotatable in said drum cavity to receive nails in sequence from said nail aligning passage and deliver nails to said nail feeding bore, pinion gears disposed between said rack

bore, racks engageable with said pinion gears and movable in opposite directions in said rack bores, means engageable by said racks to operate said reciprocable means and said drum, and a plunger connected with one of said racks and movable in said nail feeding bore to propel nails in sequence along said bore; a nailing structure reciprocable relative to said nail feeding structure and defining a nail transfer chamber having an entrance movable into position to receive nails from said nail feeding bore, and a nail guiding bore communicating with the nail transfer chamber, said nailing structure being connected to one of said racks to effect movement thereof on relative reciprocation of said nail feeding and nailing structures; and means for driving a nail present in said nail guiding bore.

4. In a nailing machine, a nailing head, comprising: a housing structure formed of non-magnetic material and defining a nail guiding bore, and a transfer chamber at one side thereof; plate magnets at opposite sides of said chamber so disposed as to tend to retard movement of the head portion of a nail toward said guiding bore; yieldable means for deflecting a nail into said guiding chamber; a magnet element disposed adjacent said guiding bore to retain nail therein against the force of gravity; and means for driving a nail from said guiding bore.

References Cited in the file of this patent

UNITED STATES PATENTS

2,866,974	Hoffman	Jan. 6, 1959
2,938,213	Gorn	May 31, 1960
2,953,787	Ollig	Sept. 27, 1960