



US 20040118168A1

(19) **United States**

(12) **Patent Application Publication**

Woo et al.

(10) **Pub. No.: US 2004/0118168 A1**

(43) **Pub. Date: Jun. 24, 2004**

(54) **LIFT OF DRUM-TYPE WASHING MACHINE AND DRUM-TYPE WASHING MACHINE USING THE SAME**

Publication Classification

(51) **Int. Cl.7** **D06F 37/06**

(52) **U.S. Cl.** **68/142; 68/24; 68/58; 68/207**

(75) **Inventors: Kyung Chul Woo, Seoul (KR); Jun Woo Kim, Gwangmyeong-si (KR); Tae Hee Lee, Seoul (KR); Hyun Seok Seo, Incheon-si (KR); Jin Woong Kim, Gwangmyeong-si (KR); Soo Young Oh, Seoul (KR)**

(57) **ABSTRACT**

A lift of a drum-type washing machine is constructed as a tandem-structure lift, which includes outer and inner lift parts. The outer lift is axially installed on an inner circumferential surface of a rotating drum provided with a multitude of water penetration holes, and the inner lift part is provided with an open bottom and perforations throughout its surfaces and is slidingly installed within the outer lift part. The outer lift part has an open top and an open bottom, with the open bottom facing at least a portion of the water penetration holes. Three such lifts, spaced equidistantly around the drum, are typically provided in a drum-type washing machine. As the drum rotates, the inner lift parts protrude, one by one, through the open top of the corresponding outer lift part, causing laundry to fall a greater distance and allowing washing water to spray through the perforations onto the laundry.

Correspondence Address:
GREENBLUM & BERNSTEIN, P.L.C.
1950 ROLAND CLARKE PLACE
RESTON, VA 20191 (US)

(73) **Assignee: LG Electronics Inc., Seoul (KR)**

(21) **Appl. No.: 10/669,430**

(22) **Filed: Sep. 25, 2003**

(30) **Foreign Application Priority Data**

Sep. 25, 2002 (KR) P2002-0058183

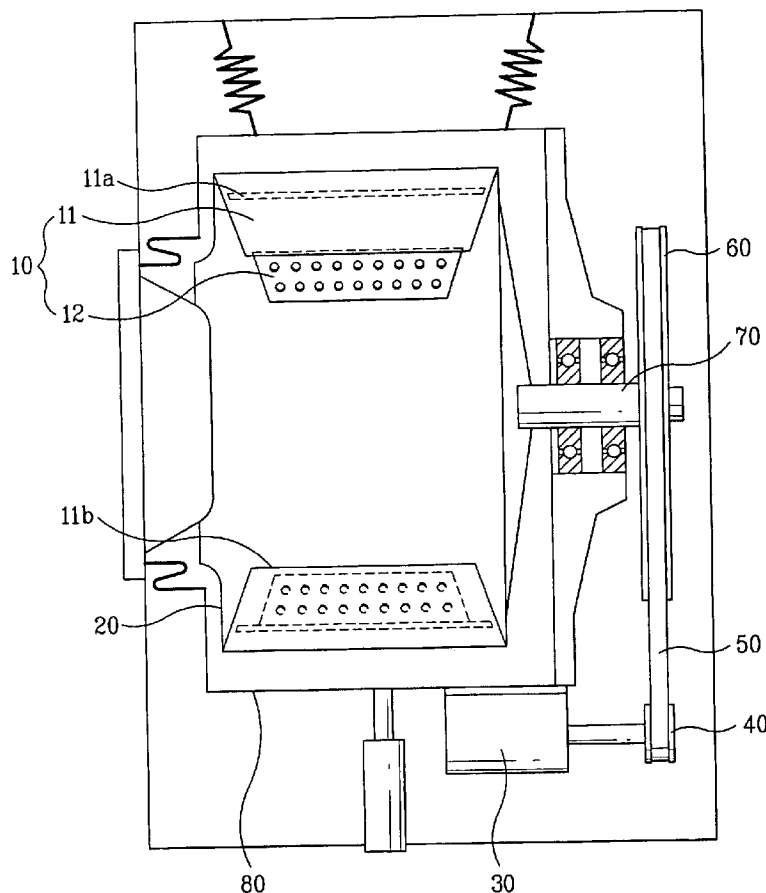

FIG. 1
Related Art

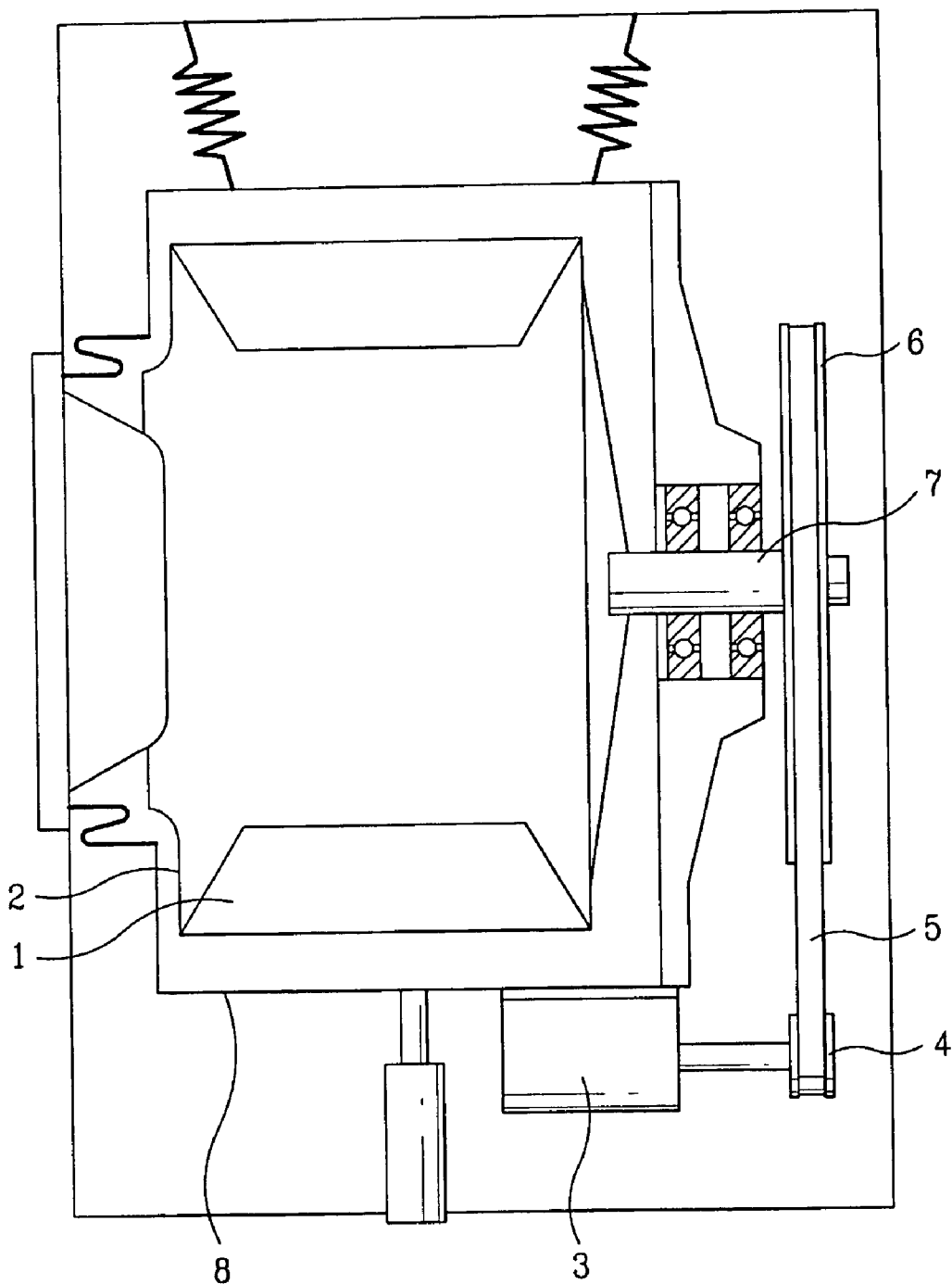

FIG. 2
Related Art

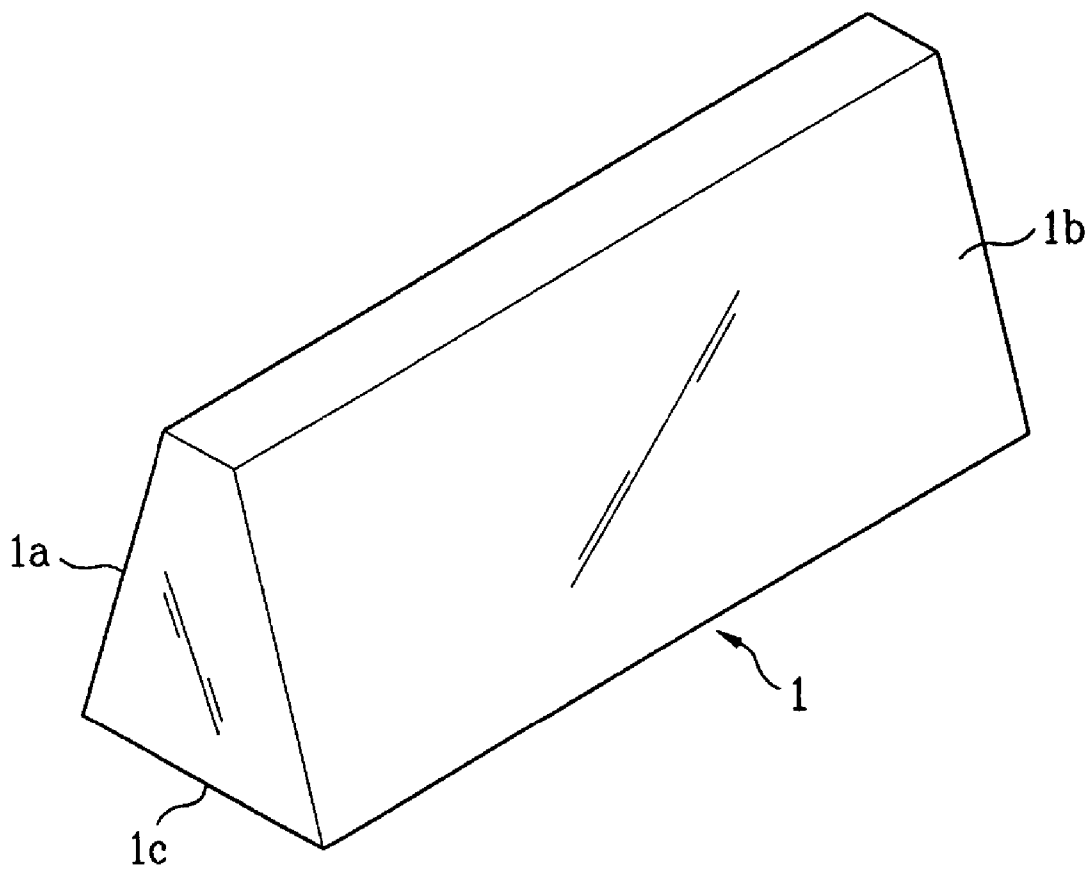

FIG. 3

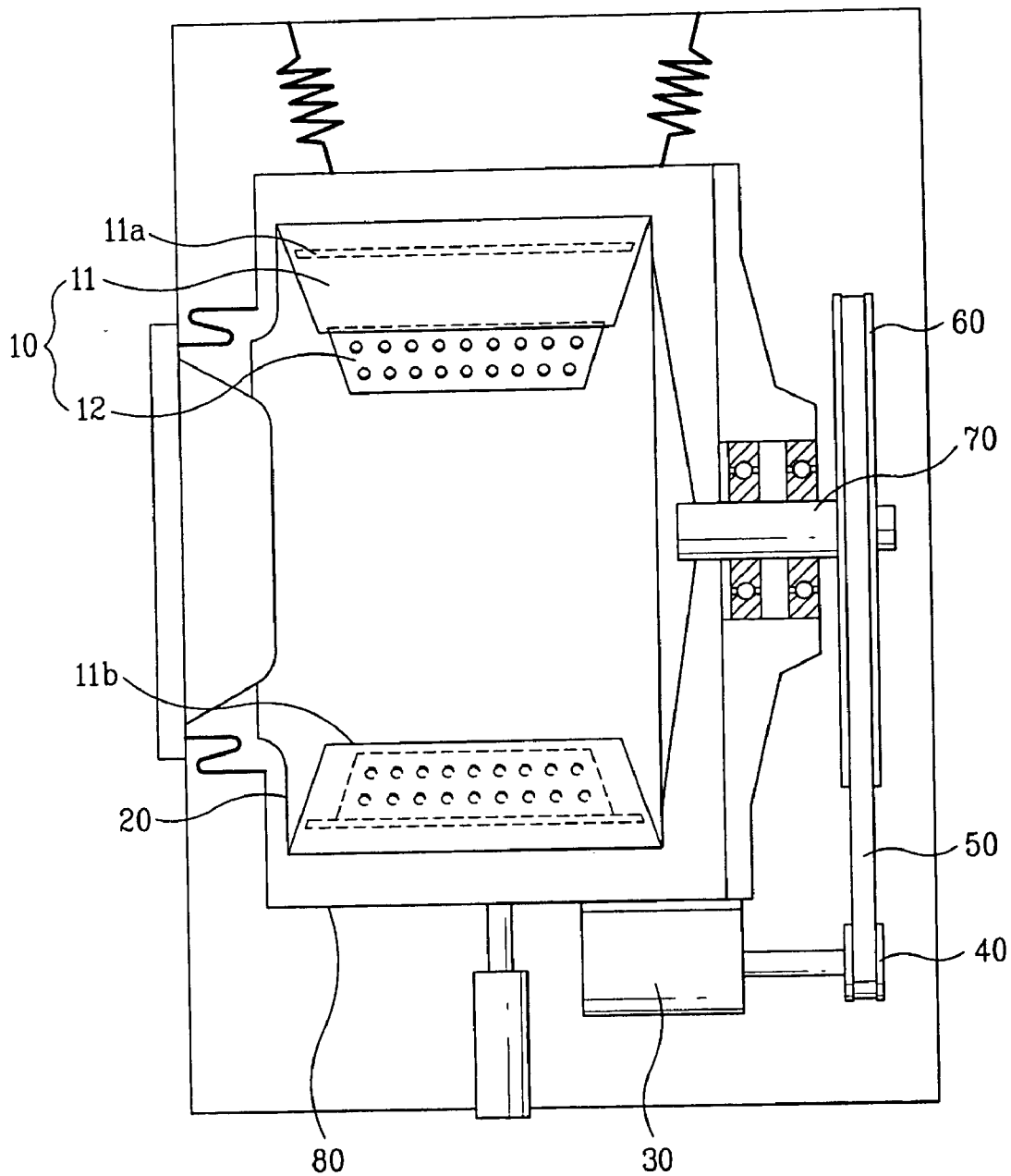

FIG. 4

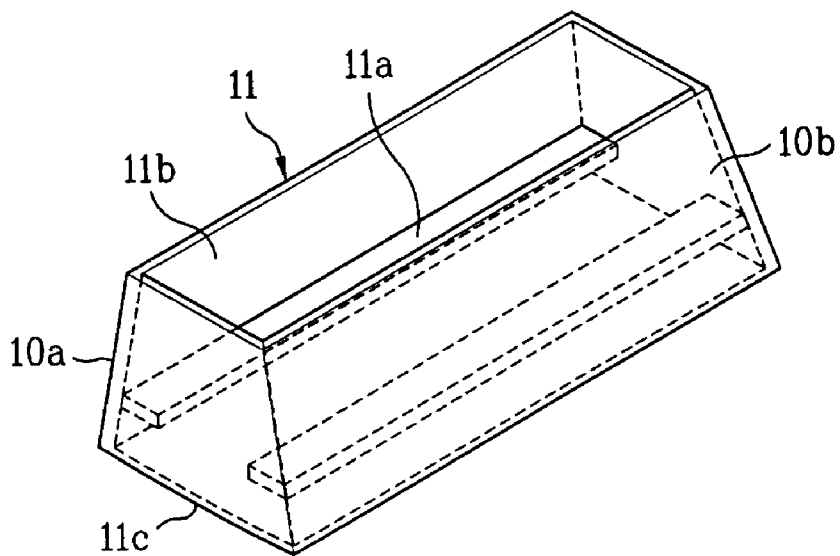

FIG. 5

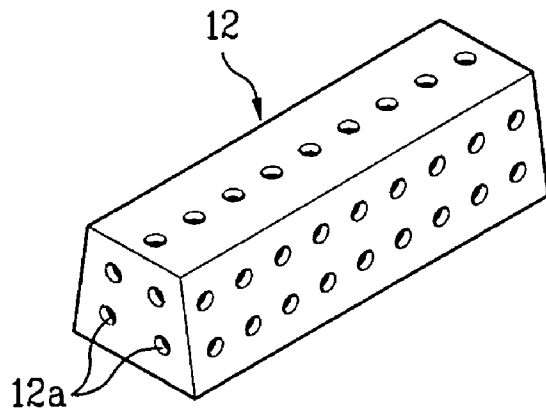

FIG. 6

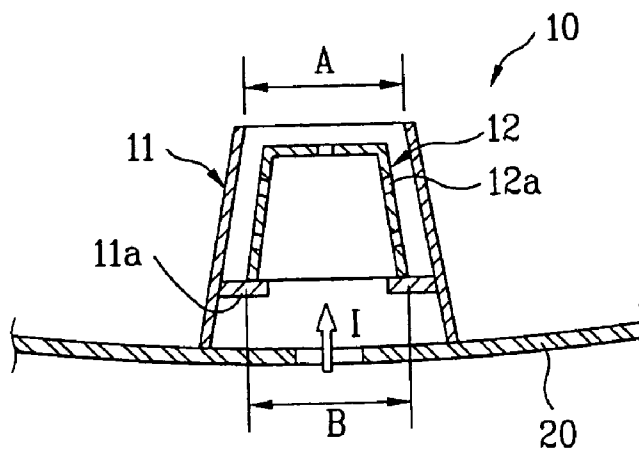
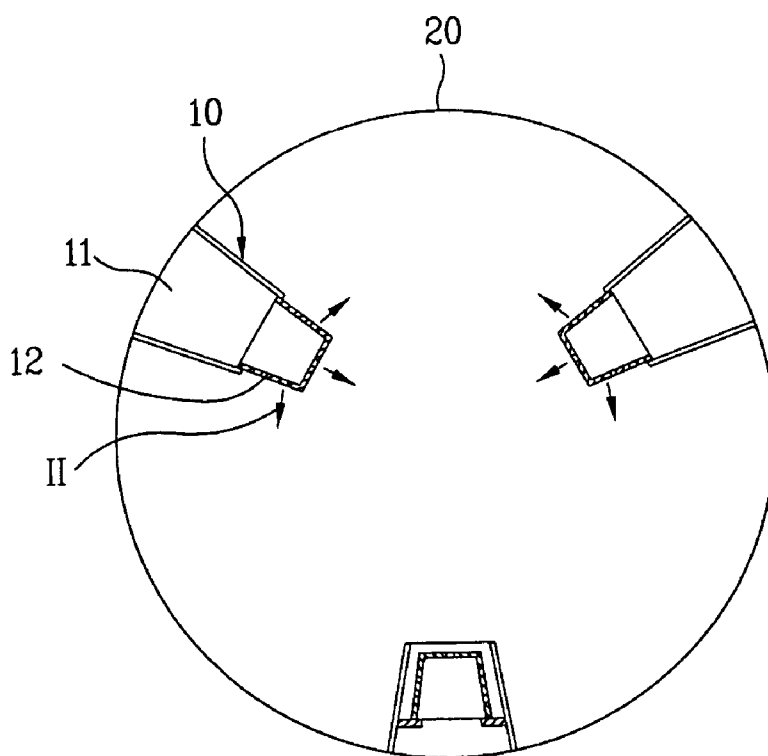

FIG. 7



**LIFT OF DRUM-TYPE WASHING MACHINE AND
DRUM-TYPE WASHING MACHINE USING THE
SAME**

[0001] This application claims the benefit of the Korean Application No. 10-2002-0058183 filed on Sep. 25, 2002, which is hereby incorporated by reference in its entirety.

BACKGROUND OF THE INVENTION

[0002] 1. Field of the Invention

[0003] The present invention relates to a drum-type washing machine, and more particularly, to a drum-type washing machine in which a tandem-structure lift is utilized.

[0004] 2. Discussion of the Related Art

[0005] Generally speaking, laundering using a drum-type washing machine is carried out using a frictional force between the laundry and a rotating drum that receives the driving force of a motor. Such a method causes little damage to the laundry, prevents the laundry from getting tangled, and achieves such washing effects as beating and rubbing.

[0006] FIG. 1 illustrates a drum-type washing machine according to a related art, having a plurality of lifts 1 provided inside a drum. An example of such a lift is shown in FIG. 2.

[0007] Referring to FIG. 1, a drum 2 having a cylindrical shape for holding and washing laundry is mounted within a tub 8 for holding washing water, such that the drum lies parallel with respect to a foundation. A rotating shaft 7 is connected to the drum 2 to rotate the drum forwardly and reversely, thereby enabling to wash the laundry inside the drum. This rotating action results from a rotating force transferred to the drum 2 using an electrical motion system made up of a motor 3 that drives a belt 5 linking a pair of pulleys 4 and 6, thus allowing full directional control of the rotation of the drum.

[0008] The lifts 1, preferably three in number, are evenly spaced around the drum 2. Each lift 1 is fixed to an interior surface of the drum 2, extending the full depth of the drum's interior, in parallel with the rotational shaft 7. The drum 2 is perforated by a multitude of water penetration holes (not shown) allowing the flow of washing water from the tub 8 into the drum 2. Each lift 1 is a polyhedron of a fixed height, having a regular trapezoidal cross-section formed between inclined side surfaces 1a and 1b, such that a bottom surface 1c of each lift is a solid face.

[0009] In the operation of a drum-type washing machine constructed as above, laundry is placed in the drum 2, water is supplied to the tub 8, and the rotating shaft 7, driven by the motor 3, rotates the drum. As the drum 2 rotates, the laundry is lifted by at least one of the lifts 1, from a lower area of the drum's interior and up one side of the interior, until reaching a point where the inclined side surface 1a or 1b passes a plane level to the foundation, whereupon the lifted laundry falls back down to the drum's lower area. The falling point is determined in part by the lift's height, which extends into the interior of the drum 2. The laundry is thus washed by a combination of actions occurring in the washing water, including the drum's rotation and the laundry's lifting and falling.

[0010] It is preferable that the height of the lifts allows for a maximized falling distance so that optimum washing effect

is achieved and a vigorous sudsing action is produced, which is further enhanced by optimizing the flow of washing water within the drum. At the same time, however, the height of the lifts should also allow for maximum laundry capacity within the drum's interior.

[0011] In the drum-type washing machine as above, each bottom surface 1c is a solid face abutting the interior surface of the drum 2 and thus impeding the free flow of washing water from the tub 8 into the drum, which reduces the effect of the washing action by rendering ineffective a portion of the water penetration holes. Furthermore, the height of the lifts is a compromise between a preferred falling distance and a maximized laundry capacity. As a result, the overall washing performance of the drum-type washing machine is reduced, and washing time must be increased accordingly, which is inefficient.

SUMMARY OF THE INVENTION

[0012] Accordingly, the present invention is directed to a lift of a drum-type washing machine, and a drum-type washing machine using the same, that substantially obviates one or more problems due to limitations and disadvantages of the related art.

[0013] It is therefore an object of the present invention to provide a lift and drum-type washing machine, by which improved washing performance is enabled and washing time is reduced accordingly, through a utilization of a tandem-structure lift to increase washing effect by facilitating a sudsing action through an unrestricted flow of washing water and a greater falling distance of laundry within a rotating drum.

[0014] It is another object of the present invention to provide a lift of a drum-type washing machine, which increases the washing action.

[0015] It is another object of the present invention to provide a lift of a drum-type washing machine, which reduces washing time.

[0016] It is another object of the present invention to provide a lift of a drum-type washing machine, which allows washing water to enter the drum through the lifts.

[0017] It is another object of the present invention to provide a lift of a drum-type washing machine, which achieves a variable height during operation of the drum-type washing machine.

[0018] It is another object of the present invention to provide a lift of a drum-type washing machine, which increases the falling distance of laundry.

[0019] It is another object of the present invention to provide a lift of a drum-type washing machine, which maximizes both drum capacity and laundry falling distance.

[0020] It is another object of the present invention to provide a drum-type washing machine, which provides an improved utilization of washing water perforations.

[0021] Additional advantages and features of the invention will be set forth in part in the description which follows, and in part will become apparent to those having ordinary skill in the art upon examination of the following or may be learned from practice of the invention. The objectives and other advantages of the invention may be realized and

attained by the structure particularly pointed out in the specification and claims hereof as well as the appended drawings.

[0022] To achieve these objects and other advantages and in accordance with the purpose of the invention, as embodied and broadly described herein, there is provided a lift of a drum-type washing machine, comprising an outer lift part axially installed on an inner circumferential surface of a rotating drum provided with a multitude of water penetration holes, the outer lift part having an open top and an open bottom, wherein the open bottom faces at least a portion of the multitude of water penetration holes. The lift further comprises an inner lift part portion, slidably installed within the outer lift part and provided with an open bottom and a plurality of perforations formed throughout its surfaces.

[0023] According to the present invention, the inner lift part portion protrudes through the open top of the outer lift part during at least a portion of a rotational cycle of the rotating drum, namely, during the upper half of the drum's rotational cycle, but is wholly contained within the outer lift part during at least a portion of the rotational cycle of the rotating drum, namely, during the lower half of the drum's rotational cycle.

[0024] According to another aspect of the present invention, there is also provided a drum-type washing machine, comprising a rotating drum provided with a multitude of water penetration holes; a plurality of outer lifts axially installed on an inner circumferential surface of the rotating drum, each of the outer lifts having an open top and an open bottom, wherein the open bottom faces at least a portion of the multitude of water penetration holes.

[0025] It is to be understood that both the foregoing general description and the following detailed description of the present invention are exemplary and illustrative and are intended to provide further explanation of the invention as claimed.

BRIEF DESCRIPTION OF THE DRAWINGS

[0026] The accompanying drawings, which are included to provide a further understanding of the invention and are incorporated in and constitute a part of this application, illustrate embodiment(s) of the invention and together with the description serve to explain the principle of the invention. In the drawings:

[0027] FIG. 1 is a cross-sectional side view of a drum-type washing machine according to a related art;

[0028] FIG. 2 is a perspective view of one lift of the drum-type washing machine shown in FIG. 1;

[0029] FIG. 3 a cross-sectional side view of a drum-type washing machine having a plurality of lifts according to the present invention;

[0030] FIG. 4 is a transparent perspective view of an outer lift part of the drum-type washing machine shown in FIG. 3;

[0031] FIG. 5 is a perspective view of an inner lift part of the drum-type washing machine shown in FIG. 3;

[0032] FIG. 6 is a cross-sectional view of one lift of the drum-type washing machine shown in FIG. 3; and

[0033] FIG. 7 is a schematic front view of the interior of the drum of the drum-type washing machine shown in FIG. 3.

DETAILED DESCRIPTION OF THE PREFERRED EMBODIMENT

[0034] Reference will now be made in detail to the preferred embodiment(s) of the present invention, examples of which are illustrated in the accompanying drawings. Throughout the drawings, like elements are indicated using the same or similar reference designations where possible.

[0035] FIG. 3 illustrates a drum-type washing machine according to the present invention. As in the case of the conventional art, the drum-type washing machine is provided with a drum 20 having a cylindrical shape for holding and washing laundry. The drum 20 is mounted within a tub 80 for holding washing water, such that the drum lies parallel with respect to a foundation. A rotating shaft 70 is connected to the drum 20 to rotate the drum forwardly and reversely, thereby enabling to wash the laundry inside the drum. This rotating action results from a rotating force transferred to the drum 20 using an electrical motion system made up of a motor 30 that drives a belt 50 linking a pair of pulleys 40 and 60, thus allowing full directional control of the rotation of the drum.

[0036] The drum 20 is provided with a plurality of tandem-structure lifts 10 installed so as to be spaced equidistantly around an inner circumferential surface of the drum. Each tandem-structure lift 10 is comprised of an outer lift part 11, fixed to the drum's inner circumferential surface, and an inner lift part 12 slidably captured within the outer lift part 11 to move freely, in and out, through a top opening 11b of the outer lift part according to the drum's rotation. The sliding action is facilitated owing to the geometrically similar structure of the outer and inner lift parts 11 and 12. The outer and inner lift parts 11 and 12 are shown in greater detail in FIGS. 4 and 5, respectively, and their correlating structure and relative configuration with respect to the drum is shown in FIG. 6.

[0037] Referring to FIG. 4, each outer lift part 11 has an open interior space for receiving the corresponding inner lift part 12, and the cross-section of either lift part has a regular trapezoidal shape. The outer lift part 11 includes a pair of support rails 11a, which protrude inwardly from each inner side surface of the outer lift part and run lengthwise from end to end, thus extending axially with respect to the drum's rotation. Notably, each outer lift part 11 is provided with a bottom opening 11c in addition to the top opening 11b.

[0038] Referring to FIG. 5, the inner lift part 12 has an open bottom, to allow the washing water to enter, and a multitude of perforations 12a for ejecting the washing water. With the outer lift part 11 fixed to the drum's inner circumferential surface, the inner lift part 12 either rests on the support rails or slides through the top opening 11b of the outer lift part 11, according to the rotational state of the drum 20. In any event, the inner lift part 12 remains captured within the interior space of the outer lift part 11, since a width B, representing the outer dimension of the bottom of the inner lift part 12, is greater than a width A, representing an inner dimension of the top of the outer lift part 11. That is, as shown in FIG. 6, in a state where the inner lift part 12 slides through the top opening 11b of the outer lift part 11,

the wider bottom of the inner lift part **12** is caught by the narrower top of the outer lift part **11** and is retained within the outer lift part.

[0039] In the operation of the above-constructed drum-type washing machine according to the present invention, laundry is placed in the drum **20**, water is supplied to the tub **80**, and the rotating shaft **70**, driven by the motor **30**, rotates the drum. As the drum **20** rotates, each lift **10** travels from a position below the drum's horizontal diameter to a position above the drum's horizontal diameter. Accordingly, by the force of gravity, the inner lift part **12** rests on support rails **11a** of the outer lift part **11** while the tandem-structure lift **10** is still in the lower half of the drum **20**. Then, also by the force of gravity, the inner lift part **12** slides through the top opening **11b** of the outer lift part **11** when the tandem-structure lift **10** enters the upper half of the drum **20**. Here, it should be appreciated that, in the tandem-structure lift **10** according to the present invention, the inner lift part will slide into a fully extended position before an inclined side surface **10a** or **10b** of the corresponding lift passes through a plane level to the foundation. Moreover, each lift **10** collects laundry while in the lower half of the drum **20** and then continues upward, to the upper half, to a point where one of the inclined side surface **10a** or **10b** passes through the plane to allow the laundry to fall. Therefore, immediately preceding the point where the laundry falls, the inner lift part **12** slides out through the top opening **11b** of the outer lift part **11** and thus extends the height of the lift so that the laundry falls a greater distance than that produced by the lift of the drum-type washing machine in the related art.

[0040] Meanwhile, the washing water flows from the tub **80** into the drum **20** through the water penetration holes perforating its circumferential surface, filling the tandem-structure lift **10** when it is situated in the lower half, by passing through the bottom opening **11c** of the outer lift part **11** and through the perforations **12a** of the inner lift part **12**, as indicated by an arrow I in FIG. 6. Thereafter, as a result of the rotation of the drum **20**, upon reaching the upper half of the drum where the tandem-structure lift **10** is fully extended and the laundry falls, the washing water held in each lift drains through the perforations **12a** to be thus sprayed evenly across the laundry, as indicated by arrows II in FIG. 7.

[0041] In a drum-type washing machine constructed as above, utilizing a tandem-structure lift according to the present invention, the height of the lift is variable based on whether the inner lift part rests within the outer lift part or whether the inner lift part protrudes through the top opening of the outer lift part. Thus, the capacity of the drum is maximized while the laundry falls from a higher point within the drum. In addition, the lift of a drum-type washing machine according to the present invention has an open structure allowing washing water to pass through the water penetration holes provided the circumferential surface of the drum, thus increasing washing efficiency. Washing efficiency is further enhanced by the spraying action of the washing water through the perforations of an extended inner lift part.

[0042] It will be apparent to those skilled in the art that various modifications and variations can be made in the present invention. Thus, it is intended that the present

invention cover such modifications and variations, provided they come within the scope of the appended claims and their equivalents.

What is claimed is:

1. A lift of a drum-type washing machine, comprising an outer lift part for axial installation on an inner circumferential surface of a rotating drum provided with a multitude of water penetration holes, said outer lift part having an open top and an open bottom, wherein the open bottom faces at least a portion of the multitude of water penetration holes.

2. The lift as claimed in claim 1, further comprising an inner lift part, slidably installed within said outer lift part, said inner lift part having an open bottom.

3. The lift as claimed in claim 2, wherein said inner lift part is provided with a plurality of perforations formed throughout its surfaces.

4. The lift as claimed in claim 3, wherein said inner lift part protrudes through the open top of said outer lift part during at least a portion of a rotational cycle of the rotating drum and is wholly contained within said outer lift part during at least a portion of the rotational cycle of the rotating drum.

5. The lift as claimed in claim 4, wherein a predetermined bottom outer width of said inner lift part is greater than a predetermined top inner width of said outer lift part, so that said inner lift part is captured within said outer lift part.

6. The lift as claimed in claim 5, wherein said inner lift part protrudes through the open top of said outer lift part while the lift is situated in an upper half of the rotating drum.

7. The lift as claimed in claim 6, wherein said inner and outer lift parts each have an opposing pair of inclined side surfaces so as to impart each of said inner and outer lift parts with a geometrically similar shape and a regular trapezoidal cross-section.

8. The lift as claimed in claim 1, wherein said outer lift part comprises a pair of support rails protruding inwardly from each inner side surface of said outer lift part and run lengthwise from end to end, thus extending axially with respect to the drum's rotation.

9. The lift as claimed in claim 8, further comprising an inner lift part resting on said pair of support rails while the lift is situated in a lower half of the rotating drum.

10. A drum-type washing machine, comprising:

a rotating drum provided with a multitude of water penetration holes;

a plurality of outer lift parts axially installed on an inner circumferential surface of said rotating drum, each of said outer lift parts having an open top and an open bottom,

wherein the open bottom faces at least a portion of the multitude of water penetration holes.

11. The drum-type washing machine as claimed in claim 10, further comprising a plurality of inner lift parts slidably installed within said outer lift parts, respectively, each said inner lift part having an open bottom.

12. The drum-type washing machine as claimed in claim 11, wherein said inner lift parts are provided with a plurality of perforations formed throughout their surfaces.

13. The drum-type washing machine as claimed in claim 12, wherein said inner lift parts respectively protrude through the open tops of said outer lift parts during at least a portion of a rotational cycle of the rotating drum and are

wholly contained within said outer lift parts during at least a portion of the rotational cycle of the rotating drum.

14. The drum-type washing machine as claimed in claim 13, wherein a predetermined bottom outer width of each said inner lift part is greater than a predetermined top inner width of the corresponding said outer lift part, so that said inner lift parts are captured within said outer lift parts.

15. The drum-type washing machine as claimed in claim 14, wherein at least one of said inner lift parts protrudes through the open top of one of said outer lift parts while a corresponding one of said plurality of lifts is situated in an upper half of the rotating drum.

16. The drum-type washing machine as claimed in claim 15, wherein said inner and outer lift parts each have an opposing pair of inclined side surfaces so as to impart each of said inner and outer lift parts with a geometrically similar shape and a regular trapezoidal cross-section.

17. The drum-type washing machine as claimed in claim 10, wherein said plurality of lifts are spaced equidistantly around the inner circumferential surface of said rotating drum.

18. The drum-type washing machine as claimed in claim 17, wherein said plurality of lifts numbers three.

* * * * *