

Sheet 3 Sheets.

R. Lawyer & J. C. Gaston.
Sewing Mach.

No. 101,140. Patented Mar. 22, 1870.

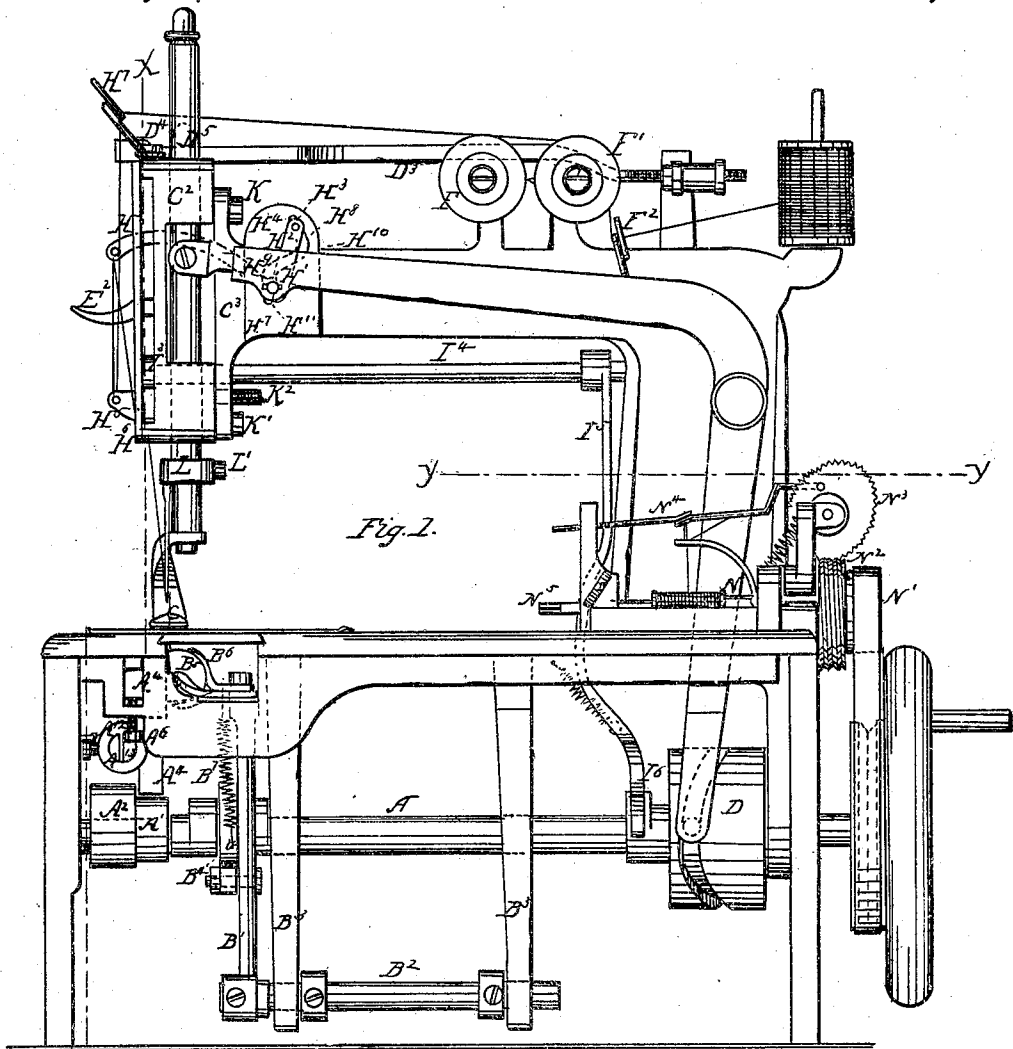

Witnesses:
Justice District
Ed. J. Tolff

Inventors:
R. Lawyer, J. C. Gaston
for
Manning & Co.
Attorneys

Sheet 2. 3 Sheets.

R. Lawyer & J. C. Gasten.

Sewing Mach.

N^o 101,140. Patented Mar. 22, 1870.

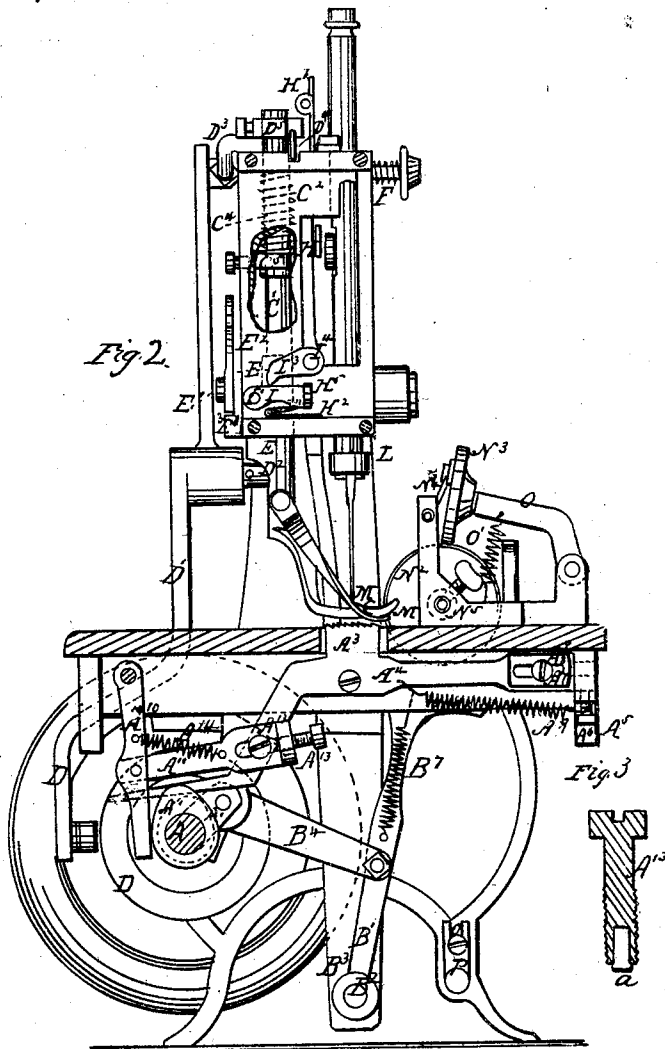

Witnesses:

Gustave Drelincour
E. S. Felt

Inventors

R. Lawyer, J. C. Gasten
per Murray & Co
Attorneys

Sheet 3 of 3 Sheets

R. Lawyer & J. C. Gaston.
Sewing Mach.

No. 101,140. Patented Mar. 22, 1870.

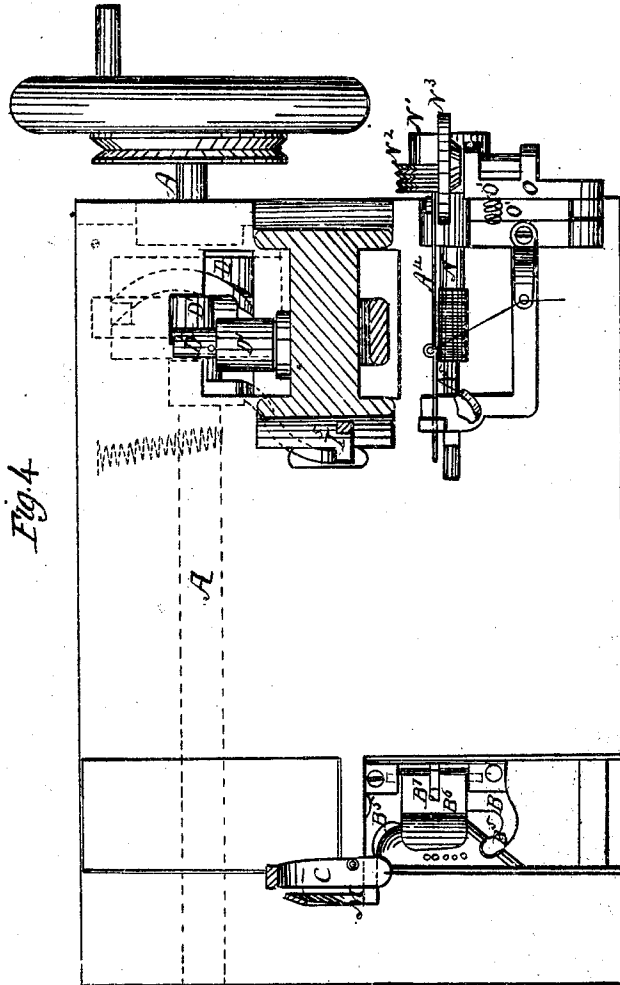

Fig 4

Witnesses:

Gustavo P. Deland
C. P. Topple

Inventor

R. Lawyer, J. C. Gaston.
per Munnell
Attorney

UNITED STATES PATENT OFFICE.

RALPH LAWYER AND JOHN C. GASTEN, OF PITTSBURG, PENNSYLVANIA.

IMPROVEMENT IN SEWING-MACHINE.

Specification forming part of Letters Patent No. **101,140**, dated March 22, 1870.

To all whom it may concern:

Be it known that we, RALPH LAWYER and JOHN C. GASTEN, of Pittsburg, in the county of Allegheny, and in the State of Pennsylvania, have invented a new and useful Improvement in Sewing-Machines; and we do hereby declare that the following is a full, clear, and exact description thereof, which will enable others skilled in the art to make and use the same, reference being had to the accompanying drawings, forming part of this specification.

This invention relates to sewing-machines; and consists in certain improvements thereon, which will be more particularly specified hereinafter.

Figure 1 is a side elevation of our improved machine. Fig. 2 is a transverse sectional elevation. Fig. 3 is a sectional elevation of one of the adjusting-screws, and Fig. 4 is a horizontal section of the said machine.

Similar letters of reference indicate corresponding parts.

A is the main driving-shaft; A¹, the cam thereon for lifting the feed-shoe, and A² the cam for imparting the forward movement to it. A³ is the feed-shoe, and A⁴ the vibrating and sliding bar to which it is attached. This bar projects at the rear end through the bracket A⁵, as shown in dotted lines, for a support, and a set-screw, A⁶, is tapped through the under part of the bracket, against the tenon of the bar, for raising it higher or lowering it to vary the height of the feed-shoe. Inside the bracket A⁵ this bar is provided with a slotted plate, A⁷, attached to it by a set-screw, A⁸, and abutting against the said bracket, to control the longitudinal movement of the feed-shoe by arresting the backward movement of the bar, sooner or later, according to its position on the plate. The said back movement of the bar is effected by spring A⁹, connected to it and to the screw A⁶, or any other suitable support. This spring also serves to hold the bar down on the screw to prevent rattling or noise. The other end of the said bar A⁴ is bent downward, and rests on the lifting-cam A¹, and receives the up-and-down movement for raising and lowering the feed-shoe.

A¹⁰ is an arm pivoted to the frame or bed at the under side, and projecting down in front of the feeding-cam A², so as to be vibrated by it. It is connected to the feed-bar A⁴ by a con-

necting-bar, A¹¹, pivoted to it, and engaging, by a slotted connection, the screw or pin A¹² in the bar A⁴.

A¹³ is a set-screw in the end of the bar A¹¹, provided with a wood pin, *a*, in the end, Fig. 3, to prevent noise, and screwing against the shank of the screw A¹², and arranged for lengthening or shortening the connection between the bars A⁴ and A¹⁰, for lengthening or shortening the stitch. This latter bar is connected, by a spiral spring, A⁴, with a stud-pin on the frame or table, which keeps it constantly bearing against the face of the cam A² and prevents noise in running.

These arrangements are considered to be very simple and cheap in construction, and admit of readily adjusting the feed as to height and length of throw, and the parts work smoothly and with but little or no noise.

The end of the feed-bar works in a slot in the vibrating arm A¹⁰, to prevent side vibration.

The shuttle-carrier B is mounted on the top of a long arm, B¹, mounted on an oscillating support, B², suspended in arms B³, projecting downward from the under side of the table, and swings thereon, moving the said carrier through the arc of a circle. This arm B¹ is worked by a connecting-rod, B⁴, pivoted to it, and connected to a crank on the shaft A. The said rod B⁴ is attached to the arm B¹ considerably below the upper end, and thereby produces the necessary movement of the shuttle-carrier without requiring the crank to be as long as would be required if the rod was connected to the carrier or to the top of the said arm B¹, which we find works much better than the latter arrangement.

We propose to apply this mode of driving the carrier, when arranged in a race to work in a straight line, by arranging a suitable connection of the arm B¹ with the carrier to admit of it.

The carrier is provided with the arms B⁵, for taking into recesses in the ends of the shuttle, in the usual way for holding it; and, in addition to these, we provide the carrier with a hinged plate, B⁶, upon the top, and having a curved projection rising up around the side of the shuttle, to prevent it from rising up when working. This plate is so adjusted that it does not bear snugly on the shuttle, but allows space enough for the thread to pass freely. It is

held down by a spiral spring, B⁷, connected to it and to the arm B¹ below.

Is the presser, connected rigidly to the cylindrical presser-bar C¹, working in suitable bearings in the head C² of the needle and presser supporting arm C³, and it is borne downward upon the work by the spiral spring C⁴, the tension of which is regulated by the adjustable collar C⁵, the upper end of the said spring bearing against the under side of a shoulder of the head C². To impart a rising-and-falling motion to this presser for raising it to turn the cloth, we have provided, in connection with the grooved cam wheel or disk D, by which the needle-arm is worked, or it may be any other suitable cam, a lever, D¹, journaled on a stud, D², and having a stud and friction-roller taking into the groove of said cam-disk, giving the said arm vibratory motion. The upper end carries a horizontal bar, D³, connected to it for adjustment longitudinally, and riding at the other end on the top of the head C². This end is provided with an inclined plane, D⁴, which works under the projection of an adjustable collar, D⁵, on the upper end of the presser-bar, so as to raise it, to admit of turning the cloth when sewing on curved or angular lines.

The time of raising the presser relatively to the other movements may be varied by engaging the stud-pin of the said lever higher or lower in the cam-groove, for which the stud may be made adjustable; but it is necessary that the cloth be turned while the needle is down, to prevent sliding the cloth laterally.

The connection of the arm D³ with the lever D¹, and the collar D⁵ with the presser-bar, being adjustable, afford ample means for varying the movements of the presser as to the time of remaining up and the height of raising, the bar regulating the time and the collar the height.

The connection of this lever D¹ with its stud D² is such that, when the feed is to be in straight lines, and it is not necessary to raise the presser, it may be slipped outwardly on the said stud to throw the stud and friction-roller out of the groove in the cam-wheel, and thereby throw the bar D³ out of action with the presser-post.

We propose to apply this attachment to all machines, whether having a rotary or reciprocating feed.

By this arrangement we utilize the needle-cam for raising the presser, and save the expense of providing other cams for the purpose, as in other machines; but other cams may be provided for it on the driving-shaft, or the shuttle-cam of some machines may be employed in the same way.

For swinging the presser around on its vertical axis to adjust it relatively to the needle, or to the line of movement of the seam or the cloth, or for swinging it out of the way for the application of hemmers or other devices, we arrange a block, E, of rectangular or other

suitable form to prevent turning, in suitable vertical guides in the head C², to rise and fall with the presser-bar, which passes through it, the two being permanently connected when the presser is adjusted to the required position by the set-screw E¹, which, being loosened, admits of turning the presser-bar as required. This screw E¹ is also made use of as the pivot for the lifting-cam dog E², by which the presser is lifted out of action for adjusting the cloth. The lower or cam-shaped end of the said dog rests on a projection, E³, of the head C².

We propose to attach hemmers or other implements of like character used without the presser to the bent arm or connection of the presser with the presser-bar, or to the bar itself, to be brought into the proper relative position with the needle for operation by the act of turning the presser away from the needle, as above described.

For the purpose of preventing the thread from winding one part over the other, as is the case when only one disk is used, we propose to use two disks, F F¹, and to wind the thread over one and under the other, crossing it between them, as clearly represented in Fig. 1, whereby it is found to work much better in this respect than when only one tension-pulley is used. These tension-disks are placed on the needle-bar support, one in advance of the other, and immediately below the receiving side of the one F¹.

We place on the needle-arm a guide-eye, F², which, going down at the same time that the needle is forced through the cloth and the thread is relieved of the tension by the dropping of the take-up, will draw the thread from the spool, so that the tension of the thread will not in any case be affected by the frictional resistance of the spool, which varies considerably. This arrangement is applicable for use with any tension device.

H is the take-up arm. It is pivoted to the needle-arm at H¹, and provided with an arm, H², rising above the said pivot-point and carrying a stud-pin, H³, which works in a curved slot in the plate H⁴, attached to the fixed arm C³. The free end of the take-up arm projects through the head C², and has an eye, through which the thread passes after passing through another guide, H⁵, below, and before it passes down through another guide, H⁶, on the needle-bar support to the needle. Before going to the eye H⁵ it passes through the fixed guide H⁷ at the top of the head C².

The slot H⁴ in the plate is so arranged relatively to the joint of the take-up arm on the needle-arm that when the latter is going down, and the stud H³ is moving from H¹⁰ to H⁹, the free end will be thrown down faster than the needle-arm moves, so that the thread will be slack while it is being drawn into the cloth from H⁹ to H¹¹. The take-up remains stationary, or nearly so, preserving the slack condition of the thread, so that the shuttle, which is so timed in its action as to enter the loop

as soon as the needle has raised sufficiently to form it, passes through, or nearly so, during the time the stud-pin is rising from H¹¹ to H⁹.

From H⁹ to H¹⁰ the slot inclines to rearward so abruptly as to throw the tension-arm up, drawing on the upper thread simultaneously with the tension on the lower thread, which begins as soon as the shuttle passes through the loop.

At the arrival of the stud-pin at the point H¹⁰ the tension on the shuttle-thread ceases, and here the slot changes in its direction and is inclined forward, so that during the continuance of the upward movement of the needle-arm the tension on the upper thread is slacked off to prevent drawing on the under thread, which is loose during this time.

In consequence of this latter forward inclination of the slot the tension on the thread would be increased during the first part of the downward movement from the top of the slot to H¹⁰, which it is desirable should not be the case, and to prevent it we have arranged the guide H⁵ to raise and slack the thread during this time. The said guide is supported on and projects at right angles from an arm, I, pivoted at I¹ to the head C², and having a spring, I², under it to raise the free end when not pressed down by a wiper, I³, on the end of a shaft, I⁴, journaled at each end in the fixed needle arm support C² C³, and having a long arm, I⁵, running down through the table, and bearing against a cam, I⁶, acting upon it to hold the shaft I⁴ and wiper I³ to force the guide down during the time the stud-pin rises from H⁹ to H¹⁰, and to let it rise at the time the stud-pin is passing from the point H¹⁰ to the top of the slot and back again. This latter movement compensates for the rising of the take-up arm, and thereby prevents the drawing of the upper thread while the lower one is slack. This guide H⁵ may be located in any part of the machine and operated in any suitable way.

The slotted plate may be arranged with the slot projecting downward, with like results, the arm H² also projecting downward, or the plate may be on the head C², and the take-up may be connected to the needle-post.

The head C² is connected to the fixed arm C³ by the screws K K¹, passing through the part C³ and screwing into the other. This head is sometimes required to be adjusted in this connection to throw the needle forward or backward, and for this purpose we have provided the screw K², arranged to screw through the part C³ and against the part C², so that by screwing it against C², the other screws being properly unscrewed, the needle will be thrown forward, while by withdrawing it and tightening up the others it may be adjusted the other way.

For attaching the needle to the needle-bar, we make a V or other angular groove in one side of it, fitting one side of the needle-shank thereto, and clamp it into the groove by the

collar L and set-screw L', as shown in Fig. 1. The end of the needle-bar has also an axial hole at right angles to path of set-screw, so that when the shank of the needle is placed in the said hole, as is preferred, for making loop or chain stitch, then the needle is held by the end of the set-screw coming against it. The needle is represented as connected in this way in Fig. 2.

M represents a ruffler attachment, consisting of a curved bar, attached to the presser-bar by a set-screw in a detachable way, and suitably shaped to rest under the front end or toe of the presser, so that the force of the latter in pressing the cloth on the feed-shoe will be expended on the cloth in front of the needle, or on the side from which the cloth is fed, whereby, when two strips of cloth are being fed to the machine, and the upper one is held by the operator, and not permitted to move as fast as the lower one, the latter will be ruffled under the other in advance of the needle.

N is a bobbin-winding spindle, arranged on the table at the rear and parallel with the main shaft. It is provided with a pulley, N¹, for operation by a belt working over a corresponding pulley on the main shaft. The said winding-spindle is provided with a worm-wheel, N², working into another, N³, at right angles thereto, to which a guide-rod, N⁴, is connected by a pin, so as to be moved back and forth for laying the thread regularly on the shuttle-bobbin held between the spindle N and center N⁵. This wheel N³ is mounted on a vibrating support. O, held in gear by a spring, O', and is made elliptical in form, to have two quick and two slow movements during one revolution, and the rod is so connected to it that, during that part of the revolution when the connection is passing the centers, where the reciprocating movement would be slower if the wheel were round, the said movement will have the same speed as at other parts thereof.

For tightening the treadle-shaft down in its bearings as it wears and becomes loose, we have provided, in suitable grooves in the frame leading to the said bearings, sliding caps P, held in the said grooves by set-screws Q passing through slots in the said caps, and tightening them in the position to which they may be adjusted for taking up the slack of the journals of the said treadle-shaft.

Having thus described our invention, we claim as new and desire to secure by Letters Patent—

1. The combination of the cams A¹ and A², the feed-bar A³, vibrating bar A¹⁰, slotted connecting-bar A¹¹, connecting-screw A¹², adjusting-screw A¹³, and springs A¹⁴, all substantially as specified.
2. The combination, with the shuttle and shuttle-carrier, of the hinged plate B⁶ and spring, substantially as specified.
3. The combination, with a take-up arm, op-

erating as described, of the thread-guide H⁵, arranged for operation substantially as specified.

4. The combination, with the needle-arm, of the pivoted take-up arm H, arm H², stud-pin H³, and slotted plate H⁴, when said parts are constructed and arranged as set forth.

The above specification of our invention signed by us this 6th day of November, 1869.

RALPH LAWYER.
JOHN C. GASTEN.

Witnesses:

GEO. W. MABEE,
ALEX. F. ROBERTS.