

Oct. 6, 1925.

1,556,027

E. J. W. RAGSDALE

REAR FIRING MECHANISM FOR HIGH CAPACITY DROP BOMBS

Filed Feb. 4, 1919

2 Sheets-Sheet 1

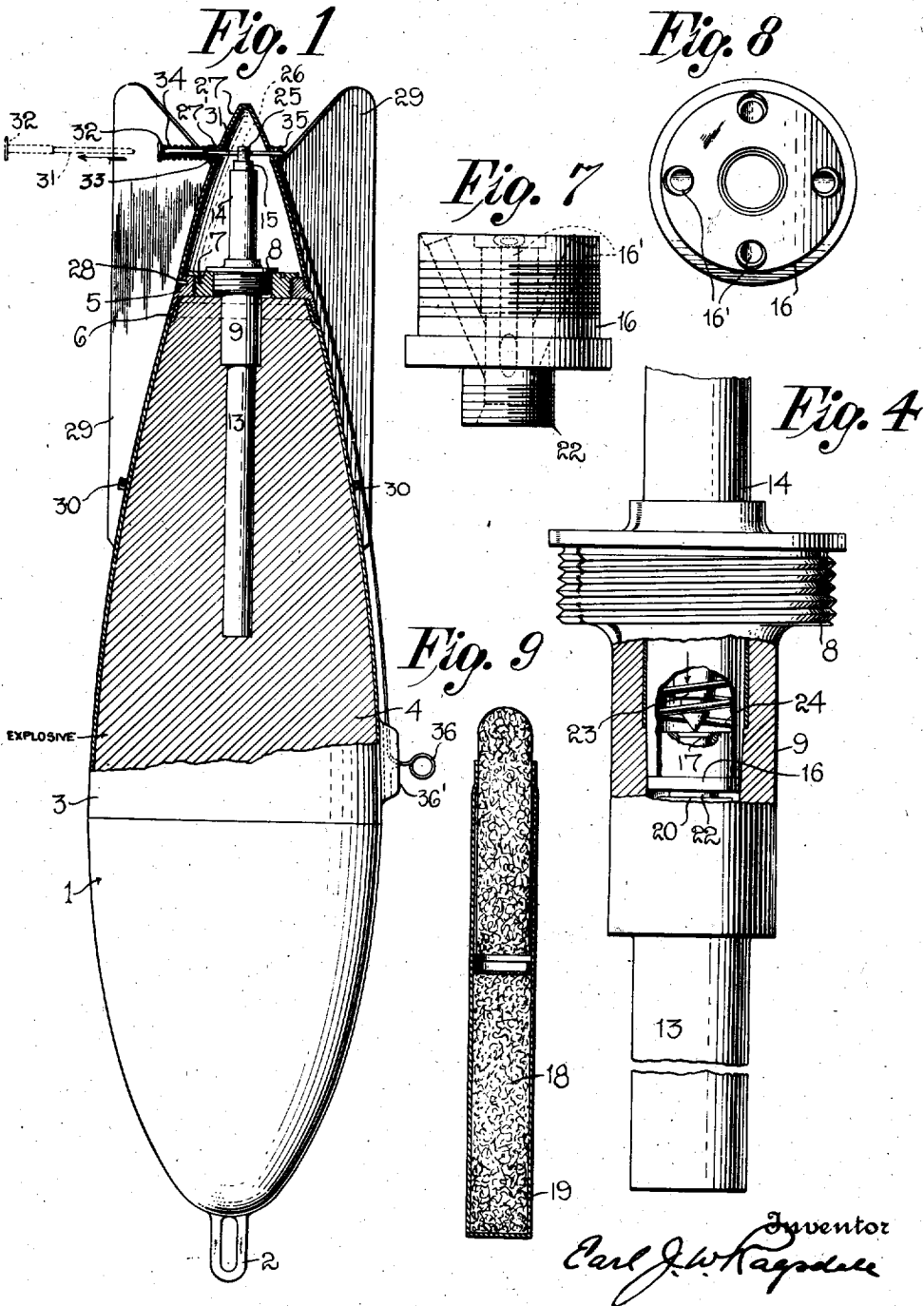

Inventor
Carl J. W. Ragdale

Oct. 6, 1925.

1,556,027

E. J. W. RAGSDALE

REAR FIRING MECHANISM FOR HIGH CAPACITY DROP BOMBS

Filed Feb. 4, 1919

2 Sheets-Sheet 2

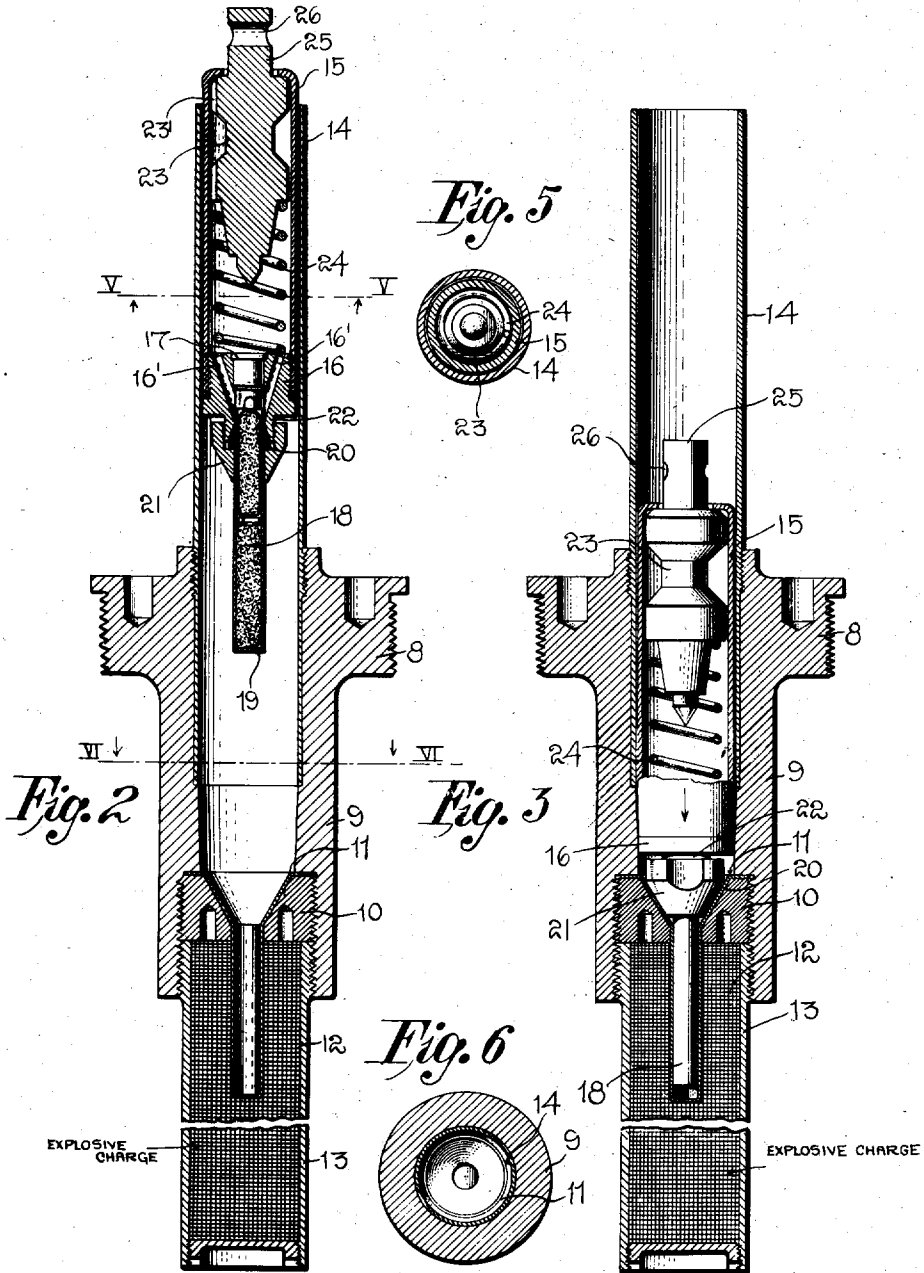

Inventor
Earl J. W. Ragdale

UNITED STATES PATENT OFFICE.

EARL J. W. RAGSDALE, OF THE UNITED STATES ARMY.

REAR-FIRING MECHANISM FOR HIGH-CAPACITY DROP BOMBS.

Application filed February 4, 1919. Serial No. 275,025.

(GRANTED UNDER THE ACT OF MARCH 3, 1883; 22 STAT. I. 625.)

To all whom it may concern:

Be it known that I, EARL J. W. RAGSDALE, lieutenant colonel, Ordnance Department, United States Army, a citizen of the United States, stationed at Washington, D. C., have invented an Improvement in Rear-Firing Mechanism for High-Capacity Drop Bombs, of which the following is a specification.

The invention described herein may be used by the Government, or any of its officers or employees in prosecution of work for the Government, or by any other person in the United States, without payment of any royalty thereon.

This invention relates to bombs or projectiles and particularly to that type of bomb which is dropped or launched from aeroplanes or other aircraft and explodes on impact.

The invention deals with the art of constructing such missiles and, more particularly, with the rear firing mechanism of the same. The firing mechanism is of the type which is maintained in normal safe position, remote from the explosive charge until the bomb is launched, and means are provided to restrain the firing pin and detonator of the firing mechanism until the launching of the bomb, and then releasing them.

Another object of the invention is to improve the construction of the bomb itself so as to simplify its manufacture and assembly; yet providing a bomb that is safe during transportation. To this end the bomb comprises two main parts, a front casing member and a rear casing member. The booster chamber and the detonator guiding tube are preferably carried by a disk member which is attached to and closes the rear end of the forward casing, while the firing pin and detonator are normally suspended in the rear casing by a spring ejected pin. The stabilizing fins are rigidly secured to the rear casing and detachably connected to the forward casing, when the bomb is assembled.

A practical embodiment of the invention is illustrated in the accompanying drawings, wherein:

Fig. 1 is a view in elevation, partly in central longitudinal section of a bomb constructed in accordance with the invention;

Fig. 2 is an enlarged view in longitudinal

section of the fuze, showing the parts in normal position;

Fig. 3 is a similar view showing the parts in armed position;

Fig. 4 is an enlarged fragmentary view in elevation of the fuze, parts broken away to show the firing pin in firing position;

Fig. 5 is a cross section taken on the line V—V of Fig. 2;

Fig. 6 is a cross section taken on the line VI—VI of Fig. 2;

Fig. 7 is an enlarged detail view in elevation of the primer casing;

Fig. 8 is a plan view of the same; and

Fig. 9 is an enlarged view in longitudinal section of the detonator.

Referring to the drawings by numerals of reference: The bomb consists of a forward casing, preferably formed of sheet metal, and comprising, for convenience of manufacture, two sections. The forward section 1 is formed with a forwardly projecting loop shaped nose 2 by which the bomb may be suspended from a suitable carrying element on an aeroplane. The rear section 3 is connected to the section 1 by welding or otherwise and the two sections form a chamber for the reception of the explosive 4.

The rear end of the casing is open and is engaged by a ring 5 which is formed with a peripheral flange, which flange is connected by spot-welding, as at 6, or in other suitable manner to the casing. The ring 5 is interiorly threaded to receive a centrally apertured member or collar 7 into which is threaded the peripheral flange 8 of the fuze-stock 9.

The forward end of the fuze-stock 9 is threaded to receive a seat or apertured plug 10 which supports a funnel shaped member 11. The member 11 projects forwardly into the explosive or booster charge 12, carried in the booster casing 13, which is threaded into the forward end of the fuze-stock and abuts against the seat 10.

A guide tube 14 is secured to the rear end of the fuze-stock, and in this tube is mounted, for rectilinear sliding movement, a sleeve 15 which forms a part of the detonator structure. A primer casing 16 is threaded into the forward end of the sleeve 15 and this casing may be provided with air-ducts 16' to aid in proper ignition of the detonator charge. The primer casing 16 is cen-

55

60

65

70

75

80

85

90

95

100

trally apertured to receive a percussion cap 17 which is positioned to ignite the detonator charge 18 carried in the casing 19. The detonator casing 19 is bound to the primer casing by means of a conical collar 20 which engages a similar seat in the primer casing and which is clamped to the casing through means of a crimp nut 21, which is threaded to a reduced forwardly projecting portion 22 of the primer casing.

A firing pin 23 is mounted for sliding movement in the sleeve 15 and is held at the rear end of the sleeve by a coiled spring 24, which is confined between the primer casing 16 and an annular shoulder formed on the firing pin. A groove or by-pass 23' extends longitudinally of the firing pin to permit escape of air, so that the forward motion of the firing pin will not be interfered with. The firing pin terminates at its rear end in a reduced portion 25, which projects through an opening provided in the rear end of the sleeve 15, the rear end being partially headed by upsetting the sleeve inwardly. An aperture 26 is formed transversely of the portion 25 to provide means for the suspension of the detonator in its rearward position, as will be explained.

A rear casing 27 open at its forward end, engages the ring 5 to which it may be secured by means of machine screws 28. Stabilizing fins or vanes are integral with or rigidly secured to the rear casing 27, and project forwardly thereof. The forwardly projecting portions of the fins 29 are detachably connected, when the bomb is assembled, to the forward casing in any suitable manner, as by means of slotted lugs and pins 30.

To furnish means for suspending the detonator in its rearmost position, the walls of the rear casing 27 are provided with aligning apertures 27', which apertures are also in alignment with the aperture 26 of the firing pin, when the firing pin is in its rearmost position. Through these aligning apertures is passed a pin 31, which is formed with a head 32. Immediately below the head 32 the pin is enlarged to support a coiled compression spring 34 which is confined in compressed condition between the head 32 and an exterior washer 33, which encircles the pin.

The pin is normally retained in this position by means of the flexible element or wire 35, one end of which is inserted through an aperture formed transversely of the projecting point of the pin, and the other end of which is looped, as at 36, to engage with the release mechanism (not shown) of an aeroplane and draw the wire from the aperture in the pin when the bomb is dropped or released from the aeroplane. The withdrawal of the wire releases the pin to be expelled by the force of the spring 34, as in-

dicated by the arrow, in Fig. 1, and free the detonator to move by the action of gravity to armed position, as indicated in Fig. 3.

The wire 35 is herein shown as passed through an apertured guide lug 36' projecting from the outer surface of the forward casing and in position to have its loop 36 attached to the aeroplane. With this arrangement the bomb is hung in a horizontal position beneath the plane.

In practice, the forward section of the shell is loaded with the explosive 4 through the aperture in the ring 5. The member 7 and the fuze are then threaded into place, and the rear casing brought to position and fastened by means of the screws 28. The pin 31 is then inserted through the aperture and locked in position by means of the wire 35.

The bomb is suspended, either horizontally or vertically, beneath the aeroplane in any usual and well known manner, and loop 36 is attached to the release mechanism so that the wire will be properly held when the bomb is launched.

Upon launching of the bomb the detonator is freed, as heretofore described, and assumes the position shown in Fig. 3 of the drawing. The detonator will seat at the forward end of the fuze without shock due to the air trapped in the tube. The firing pin, during the flight of the bomb, is held from contact with the percussion cap 17 by means of the spring 24, but, when the bomb strikes, the kinetic energy stored in the pin overcomes the resistance of the spring 24, causing the pin to impinge upon the percussion cap and detonate the detonator and booster charges to fire the explosive charge 4.

It will be understood that my invention is not limited strictly to the details described, but that a considerable range of equivalents is included within my invention as indicated by the accompanying claims.

Having described my invention, what I claim as new and desire to secure by Letters Patent, is:

1. The combination in a bomb, of a casing having a chamber for an explosive, a fuse for detonating the explosive, including a stock, a booster casing secured to the stock, a funnel shaped member extending into the booster casing, a guide tube carried by the stock, a detonator slidable in the tube and normally held at one end thereof and remote from the booster casing, said detonator formed to enter the funnel shaped member when the fuse is armed, a firing pin, means including the firing pin normally holding the detonator charge remote from the booster casing and means for holding the firing pin from the detonator until impact of the bomb.

2. The combination in a bomb, of a casing

having a chamber for an explosive, and a fuze attached to the casing comprising a stock, a booster carried by the stock, a seat between the stock and booster, a funnel shaped member carried by the seat and extending into the booster, a detonator for the fuze and movable with respect thereto to enter the funnel shaped member, means for normally holding the detonator out of the said member and means for firing the detonator upon impact of the bomb.

3. The combination in a bomb, of a body having a chamber for an explosive, a fuze attached to the body including a booster; and a detonator structure comprising a cylinder movable longitudinally of the fuze and normally held at one end thereof, a primer casing attached to the cylinder and provided with ducts, a primer in the primer casing, a detonator casing bound to the primer casing and in communication with the ducts and means movable upon impact of the bomb to fire the primer.

4. In a bomb, the combination with a forward casing having an explosive chamber open at the rear end of a ring for closing the rear end having a peripheral flange adapted to encircle the rear end of the casing and to be bound thereto, a rear casing secured to the ring, and a fuze carried by the ring.

5. In a bomb, the combination with a forward casing having an explosive chamber open at the rear end, of a ring engaging the rear end of the casing and formed with a peripheral flange encircling the rear end of the casing and bound thereto, a fuze secured in the ring, a rear casing attached to the ring, and stabilizing vanes secured to the rear casing and attached to the forward casing.

6. A bomb, embodying a body for containing explosive, a fuse stock secured to the rear end of said body, a booster casing secured to the stock, a hollow member extending into the booster casing, a guide tube secured to the stock, and a detonator slidable in the guide tube, including a primer casing, a sleeve secured to the said casing, a detonator casing secured to the primer casing and adapted to enter the hollow member when the fuse is primed, a striker

slidable in the sleeve and means for normally holding the detonator remote from the booster casing.

7. A fuse for projectiles embodying, a fuse body, a hollow member slidable in said body, firing elements carried by said hollow member, the forwardly situated one of said elements secured to the member and the rearwardly situated one free to slide in the member whereby, upon impact, the hollow member may move with respect to the fuse body and the rearwardly situated one of said elements will, due to its inertia, impinge upon the forwardly situated member to initiate detonation.

8. A fuse for projectiles embodying, a fuse body, a hollow member slidable in said body, means for normally retaining said member at one end of the body, firing elements carried by the hollow member, the forwardly situated one of said elements secured to the member and the rearwardly situated one free to slide in the member whereby, upon impact, the hollow member may move with respect to the fuse body and the rearwardly situated one of said elements will, due to its inertia, impinge upon the forwardly situated element to initiate detonation.

9. A fuse for projectiles embodying, a fuse body, a hollow member slidable in said body, firing elements carried by said hollow member, the forwardly situated one of said elements secured to the member and the rearwardly situated one free to slide in the member whereby, upon impact, the hollow member may move with respect to the fuse body and the rearwardly situated one of said elements will, due to its inertia, impinge upon the forwardly situated member to initiate detonation, and means for maintaining the elements in spaced relation during flight.

10. A fuse embodying a member adapted to slide within a fuse body and firing elements carried by the member and normally movable therewith, one of said elements free to move with respect to the member under the force of inertia to engage the other element and fire the fuse.

EARL J. W. RAGSDALE.