



(12) **EUROPEAN PATENT APPLICATION**

(43) Date of publication:
27.06.2001 Bulletin 2001/26

(51) Int Cl.7: **D02J 1/08**

(21) Application number: **00204227.3**

(22) Date of filing: **28.11.2000**

(84) Designated Contracting States:
**AT BE CH CY DE DK ES FI FR GB GR IE IT LI LU
MC NL PT SE TR**
Designated Extension States:
AL LT LV MK RO SI

(72) Inventor: **Crotti, Mariella**
25023 Gottolengo (Brescia) (IT)

(74) Representative: **De Gregori, Antonella et al**
Ing. Barzano & Zanardo Milano S.p.A.
Via Borgonuovo 10
20121 Milano (IT)

(30) Priority: **01.12.1999 IT MI992508**

(71) Applicant: **Crotti, Mariella**
25023 Gottolengo (Brescia) (IT)

(54) **A winding interweaving machine for the treatment of one or more yarns**

(57) A winding interweaving machine for the treatment of one or more yarns (12, 12', 12'') characterised in that it envisages at least one starting pack (10, 10', 10'') of at least one yarn (12, 12', 12'') and at least one

feed part (13, 15) directed towards an air interweaving device (14) before sending said interweaved yarn(s) to a picking-up spool unit (17), there being motors (18, 24) connected to a computer (20).

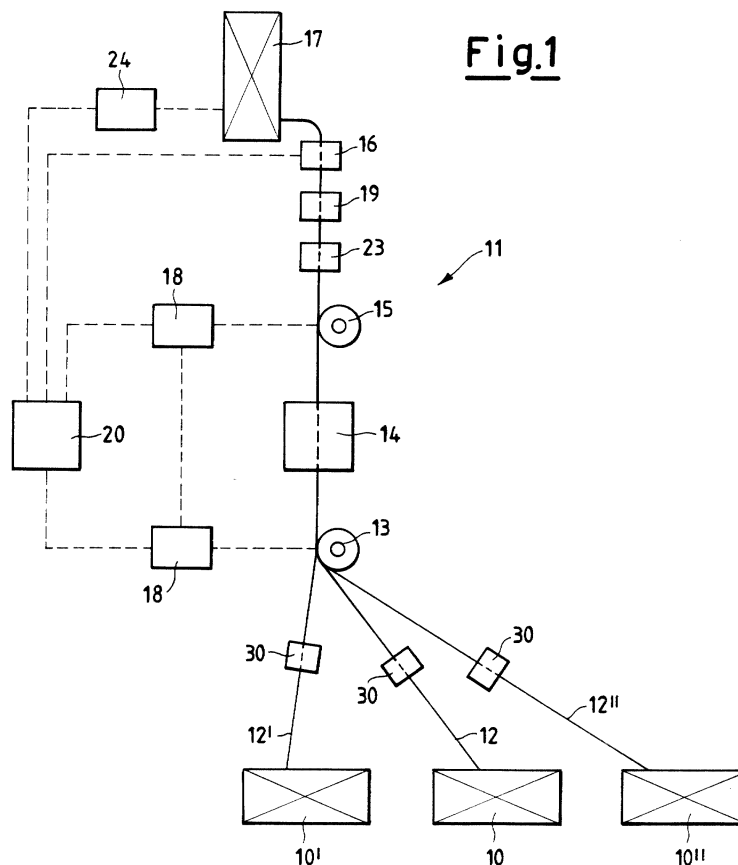

Description

[0001] The present invention refers to a winding interweaving machine for the treatment of one or more yarns.

[0002] It is known that yarns, in order to be used, moved and stored in generic "packs", must be wound on special support parts.

[0003] These "packs" have different shapes and dimensions, depending on the specific characteristics of the machine which will use them in one or more subsequent processings.

[0004] The usual winding, for example after the extrusion and/or spinning operation, is now carried out by spoolers which produce packs known as reels, generally once the yarn has been interweaved. Then the yarn, thus produced and wound onto reels, is treated on winding frames which deposit and arrange the thread onto a rotating cylinder or spool. In this case the spool simply comprises a tube or a similar taking up part, of smaller size, with or without flanges at one or both ends in order to contain the wound thread.

[0005] It is thus easily understood that in order to use the yarns thus obtained on spiralling machines or for other subsequent treatment, a first spooling operation with interweaving and a second operation of winding must be carried out in sequence.

[0006] It must also be noted that the interweaving operation of the single thread, e.g. multifilament, or of several threads is indeed currently carried out on spoolers.

[0007] This double operation, in order to arrive at the final yarn utilisable for taking up or other treatments or even for direct use on looms, requires access to spoolers and winding frames so as to arrive at the desired usable pack.

[0008] All this increases the investment costs for the purchase of the machines, in addition to the times and costs in attaining the yarn to be treated.

[0009] Moreover, a factor which cannot be overlooked is that concerning the implementation and operating speed connected with the mentioned machines. The spoolers operate at a relatively low speed, i.e. approx. 800m/min. while winding frames can even operate at triple the speed of spoolers.

[0010] Another factor not to be overlooked is that, especially with the taking up machines, one must currently start with a spool of yarn and it is not possible to directly use reels or similar packs.

[0011] Another difficulty which forms part of the overall problem connected to these treatment types is that arising from the joining of yarns to be drawn with drawn yarns, which may be required on special fancy yarns for specific uses.

[0012] This drawing operation has, until now, been carried out on yarns which are unwound from a reel and wound onto a spool, i.e. on a winding frame. In this way the yarn must be already wound on a reel to then arrange it on a spool so as to draw it, as required, during the winding operation.

[0013] It thus results that to try and speed up this operation, yarns which have already been drawn are used to wind them directly onto reels and thus avoiding the subsequent drawing operation in course of spool production. This leads to extra cost since the drawn yarn has had to undergo a previous operation and thus has a greater overall treatment cost.

[0014] The aim of the present invention is to provide a solution to this series of associated technical problems by defining a machine which allows considerable time savings with consequently reduced costs.

[0015] Another aim of the present invention is to define a machine which allows the attainment of yarns, ready for the taking up operation and for the subsequent treatments, in much reduced times.

[0016] These aims, according to the present invention, are reached by producing a winding interweaving machine for the treatment of one or more yarns according to claim 1.

[0017] Further characteristics are apparent from the additional claims.

[0018] The characteristics and advantages of a winding interweaving machine for the treatment of one or more yarns, according to the present invention, will become apparent from the description that follows and from the enclosed outline designs, supplied simply as explanatory, non-limiting examples, in which:

- figure 1 is a diagram of a machine according to the present invention in its first simplified embodiment; and
- figure 2 is a diagram of a machine according to the present invention in its second embodiment.

[0019] With reference to the diagram in figure 1, a winding interweaving machine is represented by its essential parts according to the invention, denoted as a whole by 11.

[0020] Such a machine has at least one feed yarn 12, unwound from its starting pack 10, which is made to pass over a first feed part 13, e.g. consisting of a roller.

[0021] The feed yarn 12 is then treated in an interweaving device 14 e.g. air type, which carries out the so-called "compensation" of the yarn before releasing it on a second feed part 15, this also, for instance, consisting of a roller.

[0022] Upon exit from this second feed part 15 is set a thread guide unit 16, as for example that described in the Italian patent 1.230.882 of the same applicant, which arranges the treated yarn on a spool 17 or a similar picking-up part.

[0023] The second feed part 15 can also be replaced by a yarn sensor which, in addition to fulfilling its main task, carries out the momentary constraint of the interweaved yarn before being taken up onto the spool.

[0024] In the event that the machine 11 of the present invention treats just one yarn, this yarn 12 can be a multifilament which does not need to be compensated be-

fore its interweaving 14 prior to being wound onto the spool.

[0025] It is natural that functional parts should be added to the aforesaid parts should they prove necessary for correct machine functioning. For example, suitable motors (outlined in 18) must be lined up with the first and second feed parts (13, 15), or a single motor which transmits the motion with suitable motorization to the two feed parts 13, 15, with a central computer 20 being provided.

[0026] In addition, there could also be a sensor 19 e.g. a stress sensor set before the thread guide or at any other point before the formation of the spool, which checks the presence of the yarn and the pick-up tension so as to produce continuous spools of good quality.

[0027] Indeed in this first embodiment of the machine, according to the invention, there can be additional feed yarns 12', 12" etc. which, once unwound from their starting packs 10', 10" etc. and passed over the first feed part 13, they join up with each other, then interweaved in the machine and directed to the picking-up spool 17.

[0028] Thus composite yarns can be produced which have been interweaved and are picked-up on a spool, ready for subsequent use, e.g. for taking up.

[0029] Figure 2 shows a machine 11' which, in addition to having the main parts quoted in the description in figure 1, allows the attainment of a spool with drawn yarn, due to the presence of a godet 21 between the feed yarn 12 and the first feed part 13.

[0030] The yarn 12, unwound from its starting pack 10, is wrapped onto an additional godet 21, before winding onto the first feed roller 13 and can then be treated in the interweaving device. The drawing of the yarn 12 occurs between the additional godet 21 and the first feed roller 13, before being compensated in the device 14.

[0031] In this machine 11' a second yarn 12', coming from a respective starting pack 10' can be joined to the drawn yarn 12, which passes over the first feed roller 13.

[0032] This yarn 12' can be an elasticized or texturized yarn or, in any case, a yarn which needs to be joined to the drawn yarn 12 to have a spool 17 ready for the specific use for which it is intended.

[0033] In this second example, which envisages the feeding of at least two yarns 12 and 12', an additional sensor 22 can be envisaged, alternatively or in addition to sensor 19. This additional sensor 22, of capacitive type, for example, is set, for instance, before the interweaving device 14 and checks the diameter of the yarn obtained or the presence of both the yarns 12 and 12'. In this way, one can be sure that the yarns wound onto spool 17 before the thread guide, i.e. at any point will be correctly composed as required, and if necessary signals the absence of one of the two yarns, interrupting and preventing an incorrect winding operation.

[0034] The yarns 12, 12', 12" etc. used in this machine can have the same or different count(s), can be elasticized or texturized, etc. thus allowing the direct production of spools of composite yarn, fancy yarns etc.

[0035] The presence of the thread guide 16 allows a synchronised spool rotation speed, with constant shed of programmable rotation according to needs, due to the computer 20.

[0036] The spool can be arranged on a motorised spindle so as to be able to use flanged and unflanged spools, with automatically adjusted rotation speeds to maintain a constant thread speed. Hence, there can be a separate motor 24 or the spindle can be motorized with a transmission (not shown) which takes the motion from a central motor of the machine, namely motor 18.

[0037] A thread sensor 30 is also envisaged for each feed yarn 12, 12', 12" fed into and exiting directly from the starting pack 10, 10', 10".

[0038] By eliminating a machine, i.e. the spooler, it is possible to increase the speed considerably which can be triple that of the spooler, i.e. up to 3500-3800 m/min.

[0039] The feed parts which are shown in the figures can be simply rollers, pulleys or similar controlled by one or more electronically controlled motors. The rollers or pulleys can feed and/or overfeed and/or draw the yarn to be collected on the spool due to their differentiated distribution and sequence.

[0040] There can also be a thread cutter 23, e.g. before the picking-up onto the spool, which electronically controlled by the computer 20, works in synchrony with the tension sensor 19 and/or the capacitive thread sensor 22.

[0041] It is also clearly understood that the machine treats one or more similar or different yarns, doubling them together by stitch air interweaving.

[0042] In short, it is confirmed that this machine solves the problems present in the previous machines by combining the operations. In fact the yarn which is presently interweaved using spoolers producing packs known as reels, after spooling with interweaving, then require winding frames to use the yarn thus produced on other machines.

[0043] The machine, according to the present invention, eliminates the spooler and spooling operation and the yarn is doubled and/or drawn and/or fed and simultaneously interweaved directly in a single operation, without having to go through the spooling stage.

Claims

1. A winding interweaving machine for the treatment of one or more yarns (12, 12', 12"), characterised in that it envisages at least one starting pack (10, 10', 10") of at least one yarn (12, 12', 12") and at least one feed part (13, 15) directed towards an air interweaving device (14) before sending said at least one interweaved yarn to a picking-up spool unit (17), there being motors (18, 24) connected to a computer (20).
2. A machine as in claim 1, characterised in that it en-

visages an additional feed part (15) above said air interweaving device (14) before said picking-up spool unit (17).

3. A machine as in claim 1, characterised in that there is also envisaged at least one additional starting pack (10', 10") of at least one additional yarn (12', 12") towards said at least one feed part (13, 15). 5
4. A machine as in any of the previous claims, characterised in that there is envisaged at least one sensor (19, 22) for said at least one yarn (12, 12', 12"). 10
5. A machine as in claim 4, characterised in that there is further envisaged a thread cutter (23), before the picking-up onto the spool, which is electronically controlled by said computer (20) and works in synchrony with said at least one sensor (19, 22). 15
6. A machine as in claim 4, characterised in that said at least one sensor is a tension sensor (19). 20
7. A machine as in claim 4, characterised in that said at least one sensor is a thread sensor (22, 30). 25
8. A machine as in claim 1, characterised in that there is also envisaged a drawing part (21) above said at least one feed part (13), through which the drawing of said at least one yarn (12, 12', 12") is carried out towards said air interweaving device (14). 30
9. A machine as in claim 3, characterised in that said at least one additional starting pack (10', 10") includes an elasticized yarn (12'). 35
10. A machine as in claim 3 or 9, characterised in that said at least one additional starting pack (10', 10") also includes a texturized yarn (12'). 40

40

45

50

55

Fig.1

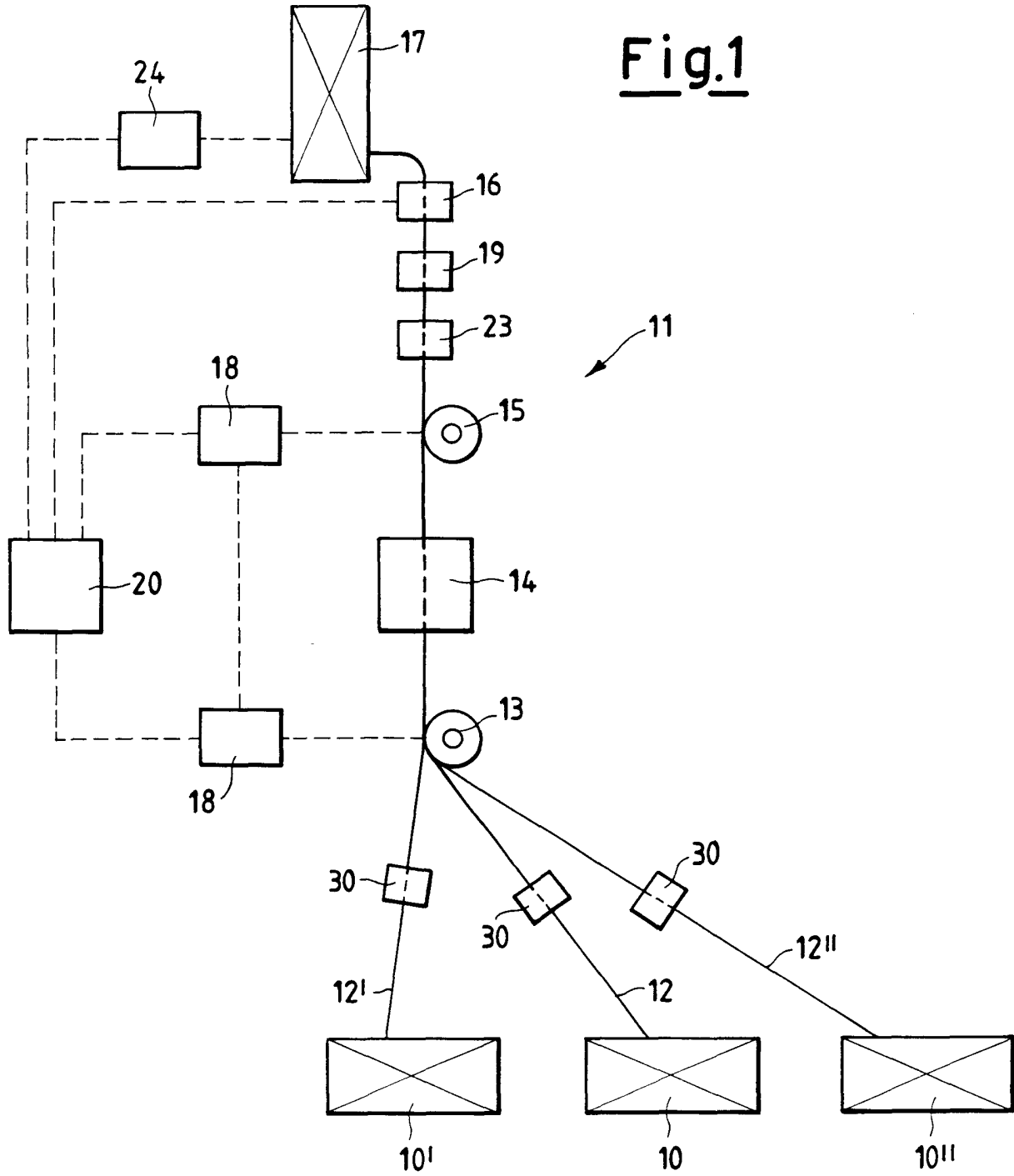
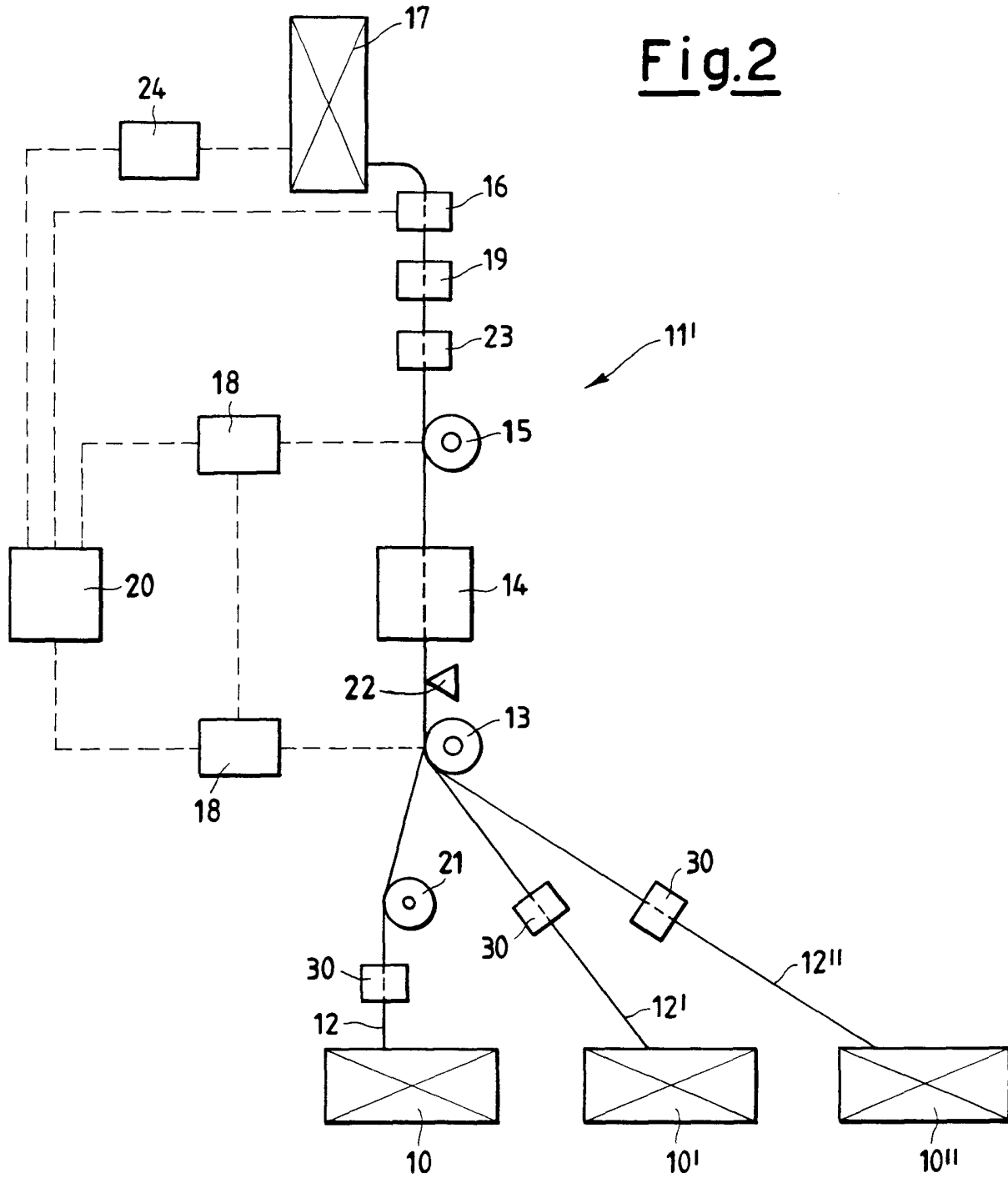

Fig.2





European Patent
Office

EUROPEAN SEARCH REPORT

Application Number
EP 00 20 4227

DOCUMENTS CONSIDERED TO BE RELEVANT			
Category	Citation of document with indication, where appropriate, of relevant passages	Relevant to claim	CLASSIFICATION OF THE APPLICATION (Int.CI.7)
X	US 4 685 179 A (SHEEHAN RICHARD W ET AL) 11 August 1987 (1987-08-11)	1-4,6	D02J1/08
A	* column 2, line 58 - column 6, line 24 * ---	8	
A	US 5 084 823 A (ANDREWS III RICHARD S ET AL) 28 January 1992 (1992-01-28)	1	
A	* column 1, line 58 - column 2, line 57 * ---	1	
A	US 4 035 880 A (HILLS WILLIAM H ET AL) 19 July 1977 (1977-07-19)	1	
	* column 3, line 54 - column 6, line 34 * -----		
The present search report has been drawn up for all claims			
Place of search		Date of completion of the search	Examiner
THE HAGUE		28 March 2001	V Beurden-Hopkins, S
<p>CATEGORY OF CITED DOCUMENTS</p> <p>X : particularly relevant if taken alone Y : particularly relevant if combined with another document of the same category A : technological background O : non-written disclosure P : intermediate document</p> <p>T : theory or principle underlying the invention E : earlier patent document, but published on, or after the filing date D : document cited in the application L : document cited for other reasons & : member of the same patent family, corresponding document</p>			

EPO FORM 1503 03 02 (P04C01)

**ANNEX TO THE EUROPEAN SEARCH REPORT
ON EUROPEAN PATENT APPLICATION NO.**

EP 00 20 4227

This annex lists the patent family members relating to the patent documents cited in the above-mentioned European search report. The members are as contained in the European Patent Office EDP file on
The European Patent Office is in no way liable for these particulars which are merely given for the purpose of information.

28-03-2001

Patent document cited in search report	Publication date	Patent family member(s)	Publication date
US 4685179 A	11-08-1987	US 4782565 A	08-11-1988
US 5084823 A	28-01-1992	AU 638770 B	08-07-1993
		AU 6651090 A	16-05-1991
		CA 2029478 A	10-05-1991
		DE 4035698 A	16-05-1991
US 4035880 A	19-07-1977	DE 2644673 A	14-04-1977
		FR 2326497 A	29-04-1977
		GB 1551854 A	05-09-1979
		JP 52053026 A	28-04-1977