

T. C. PLATH.
ELECTRIC IRON.
APPLICATION FILED NOV. 8, 1920.

1,413,057.

Patented Apr. 18, 1922.

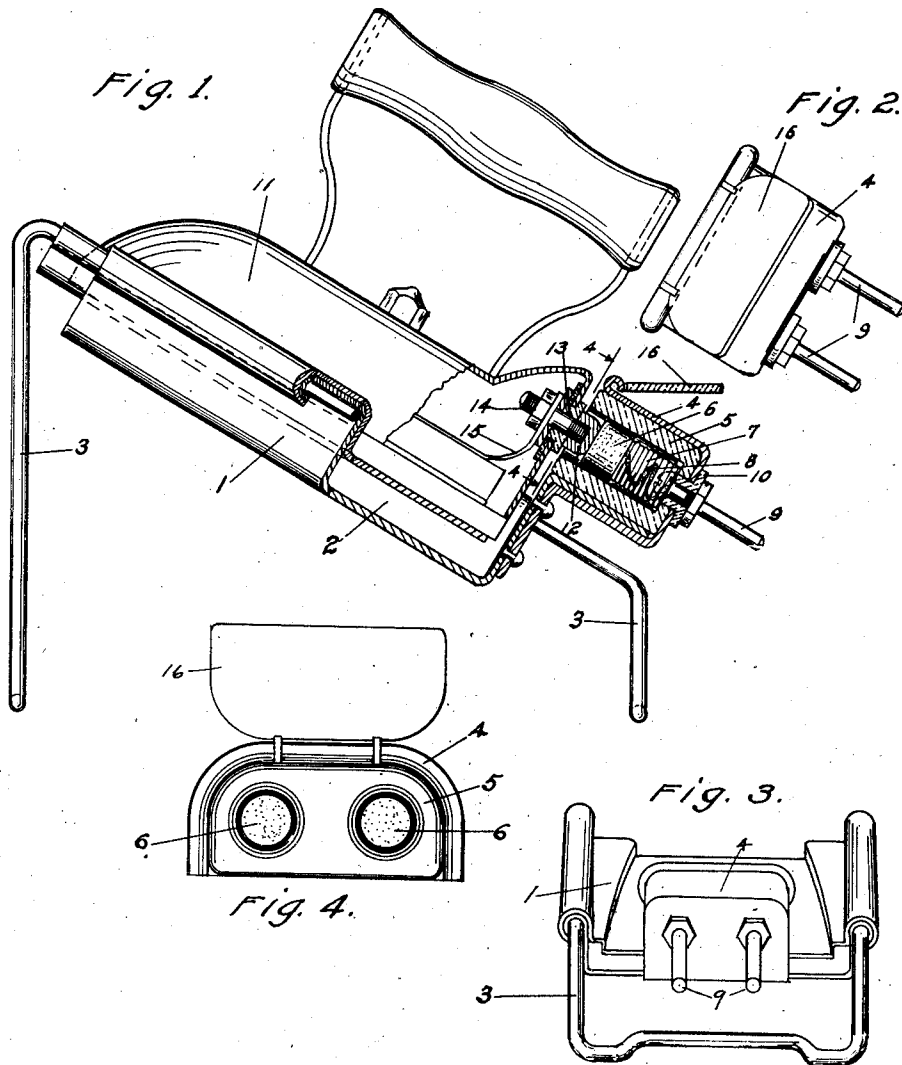

INVENTOR.
Theodore C. Plath
BY
W. H. Fitzberg
ATTORNEYS.

UNITED STATES PATENT OFFICE.

THEODORE C. PLATH, OF LOS ANGELES, CALIFORNIA, ASSIGNOR OF ONE-HALF TO
WILLIAM R. LITZENBERG AND ONE-HALF TO F. J. CATTERLIN, BOTH OF LOS
ANGELES, CALIFORNIA.

ELECTRIC IRON.

1,413,057.

Specification of Letters Patent. Patented Apr. 18, 1922.

Application filed November 8, 1920. Serial No. 422,645.

To all whom it may concern:

Be it known that I, THEODORE C. PLATH, a citizen of the United States, residing in the city of Los Angeles, county of Los Angeles, and State of California, have invented certain new and useful Improvements in Electric Irons, of which the following is a specification.

My invention relates to electric irons, and has for its primary object to provide an electric iron and a support therefor, the support having means for connecting it with a source of electric energy, with suitable terminals, and the iron also having suitable terminals adapted, when the iron is set upon the support, to contact with the terminals of the support, and thus conduct electric energy to the heating element of the iron, thus making it possible to pick up an electric iron and use it without the usual electric cord dangling in the way of the person using the iron. Every time the iron is set upon the support it is automatically connected with the source of electric energy without the necessity of the user making special connection therewith.

One of the common objections to the electric iron is the fact that the cord which conveys the electric energy to the iron is always in the way and is catching on things to the inconvenience of the user; and the iron is constantly being heated unless the cord is disconnected, or some other switch is opened, and frequently gets too hot.

With my improvement, when the iron is heated, the time it sets on the stand is sufficient to keep it in good heat for the user and there is no switch to be manipulated, or cord to be disconnected, or to get in the way of the person using the iron. Thus there is less danger of the iron being thrown off the table or support by means of the cord, which frequently damages the iron, and many times injures a person or thing as it falls. If the iron gets too hot, it is only necessary to set it down so its terminals or contacts do not engage with the terminals of the support.

In order to fully explain my invention, I have illustrated one practical embodiment thereof on the accompanying sheet of drawings, in which,—

Figure 1 is a side elevation of an iron and

support or stand embodying my invention, with parts shown in section;

Figure 2 is a top plan view of the rear portion of the stand, showing the manner of connecting the source of electric energy thereto;

Figure 3 is a rear view of the support as shown in Fig. 1; and

Figure 4 is a view on the line 4—4 of Fig. 1.

Referring now to the drawings in detail, 1, designates a support or stand, preferably of double construction whereby to provide an air space 2, therein, with supporting means, here shown as wire members 3, held in the rolled sides of the body of the stand. The front end of said stand or support is preferably higher so that the iron will rest in an inclined position and thus insure a better contact with the heating connections hereinafter described. It will be understood, of course, that any type of support or stand can be used and that it can be made portable or otherwise, as desired. At the rear of the stand, I have provided means for connecting a source of electric energy therewith. This comprises a metal enclosing member 4, with an insulating lining 5, with two carbon contact members 6, yieldingly positioned therein at the ends of two springs; 7. Said carbon contact members are connected by means of suitable metal ribbons, 8, with terminal pins, 9, insulated from the enclosing member 4, by means of suitable bushings, 10. The source of electric energy is to be connected with the terminal pins, 9, just as it is now connected with the electric irons direct, and will be readily understood.

The electric iron, 11, can be of any desired type, and is provided with two metal contact members, 12, insulated from the iron body by means of suitable bushings, 13, and connected by means of a bolt, 14, and wire, 15, with the heating element of the iron. Thus I have provided metal contact members, 12, on the iron, positioned to contact with the yielding carbon contact members, 6, carried by the stand or support 1. It will be clear that when the iron is picked up from the stand that the contact is at once broken, and that when the iron is placed again upon the stand the contact is made and the iron is again subjected to heat.

In order to provide means for placing the iron on the stand without making electrical contact between the terminals, I have provided a hinged element of non-conducting material, 16, on the enclosing member, 4, which hinged element can be dropped down in front of the terminal or contact members 6, whereby the contact members 12 of the iron will rest against said member 16.

I am aware that changes can be made in the details of my invention and that it can be applied to other electrically heated articles, without departing from the spirit thereof, and I do not, therefore, limit myself to the showing made, except as I may be limited by the hereto appended claims.

I claim:

1. In combination, an electric iron stand constructed to hold an iron in a tilted position and provided at its lower side with an enclosed box-like part, open on its side toward the supporting part of said stand and having an insulating lining, a yieldingly mounted contact member in said box-like part, electric connections through said box-like part to said contact member, a closure adapted to be moved over the open side of said box-like part, and an electric iron provided with contact member adapted to contact with the contact member of said stand when said iron is set thereon, said iron being held by gravity against said box-like part of said stand.
2. In combination, an electric iron stand having an iron supporting member in an inclined position and provided with contact elements yieldingly mounted at the lower side thereof and located within an enclosing member open at its side next to the supporting member, an electric iron having projecting contact members on its rear end adapted to extend into said enclosing member and contact with said yieldingly mounted contact elements therein when said iron is set on said supporting member, two of said contact members being of metal and two of said

contact members being of carbon, whereby to prevent crystallization when said contact members engage each other in use.

3. In combination, an electric iron having projecting contact members, a supporting stand therefor provided with an enclosing member open at one side and having an insulating lining, a yieldingly mounted contact member within said enclosing member, said enclosing member having a closure member adapted to be placed over the open side of the same whereby to cover said contact members when not used, and means whereby the iron when set on said stand is held with its contact members in contact with the contact members in said enclosing member.

4. In combination, an electric iron having two contact elements projecting therefrom, a supporting stand therefor having its supporting part in an inclined position and having at its lower side a pair of yieldingly mounted contact members positioned to engage with the contact members on said iron when the iron is placed on said stand, said contact members being of metal and carbon and adapted to contact with each other by abutment, means for connecting a source of electric energy with the contact members of said stand, protecting means enclosing said contact members on the stand and having an opening to receive the contact members on said iron when set thereon, said contacts being held in contact with each other by gravity, and a closure for the opening of said protecting means, whereby to cover the contact members and hold said iron out of contact therewith when desired, substantially as described.

Signed at Los Angeles, California, this 30th day of October, 1920.

THEODORE C. PLATH.

In presence of—
EARL B. SPENCER,
H. M. BRUNDAGE.