

(No Model.)

3 Sheets—Sheet 1.

R. M. DIXON.
STEAM HEATING APPARATUS.

No. 523,962.

Patented July 31, 1894.

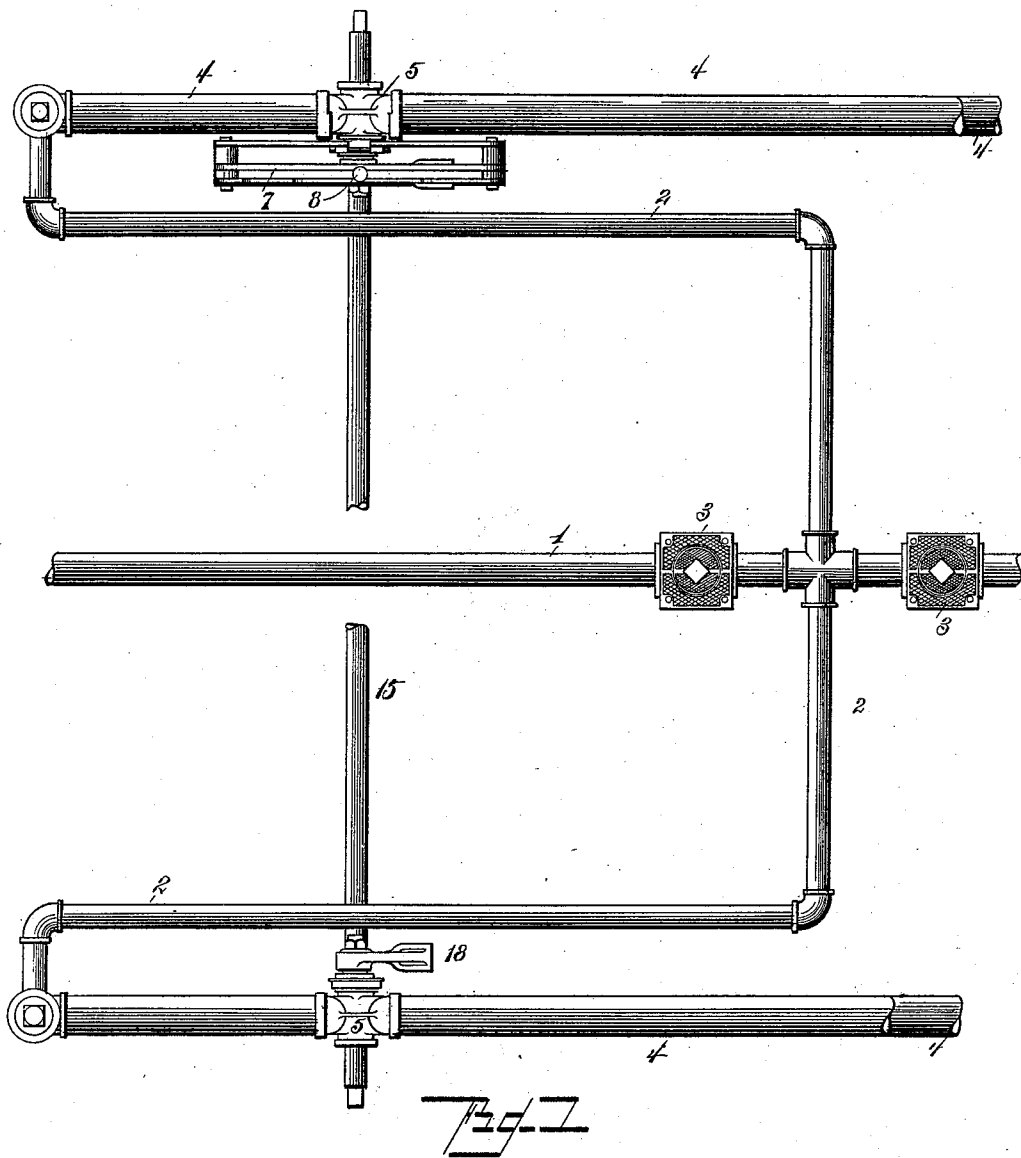
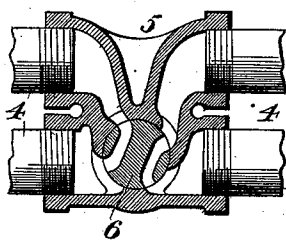

Fig. 5.



Witnesses

Louis S. Julihn.
Eric Julihn.

R. M. Dixon
Inventor

by
Hopkins & Atkins.

Attorneys

(No Model.)

3 Sheets—Sheet 2.

R. M. DIXON.
STEAM HEATING APPARATUS.

No. 523,962.

Patented July 31, 1894.

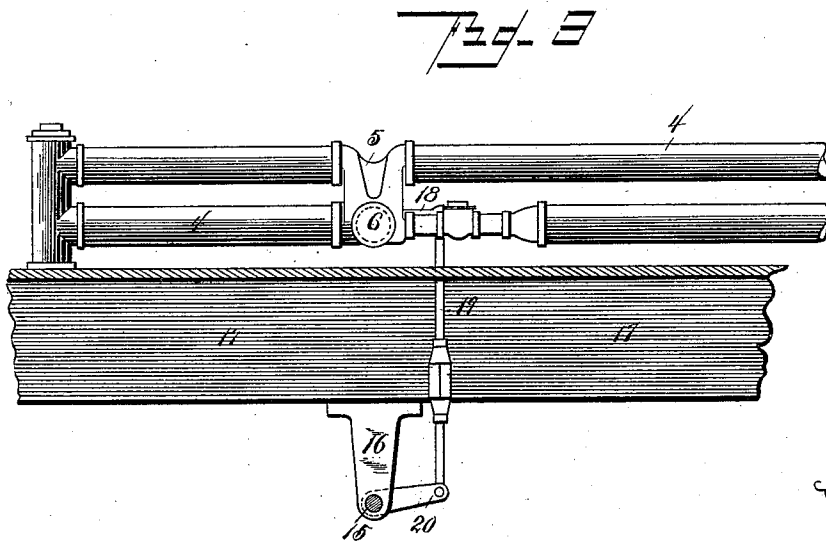
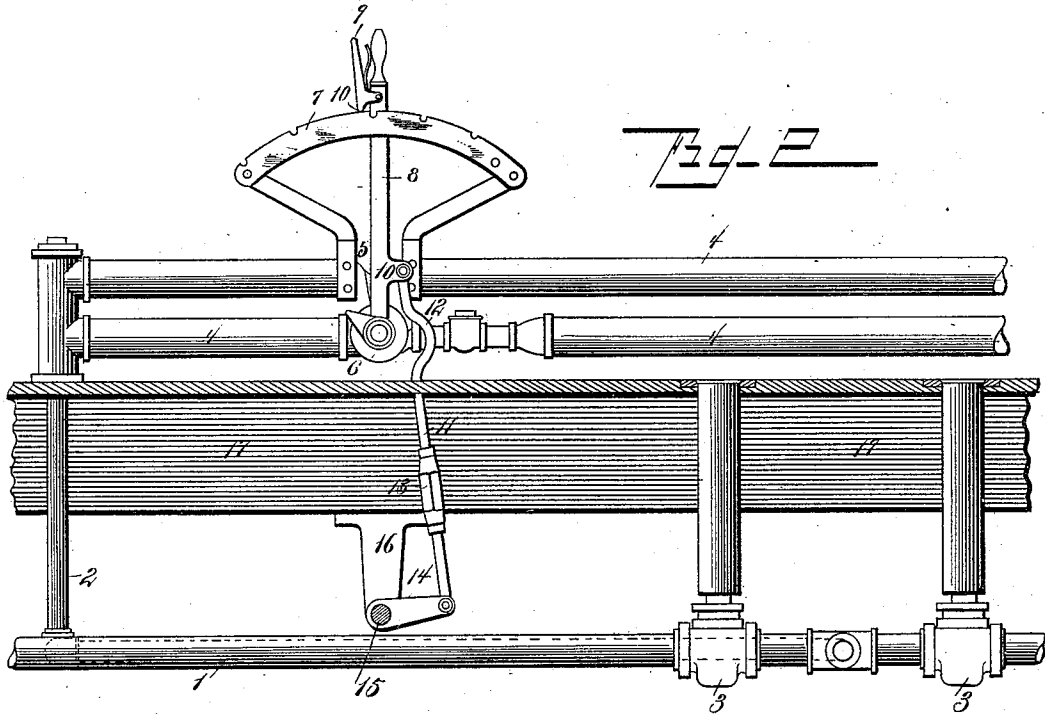

Witnesses
Louis S. Julian.
Eric S. Julian.

R. M. Dixon
 Inventor
By Hopkins & Atkins.
 Attorneys

(No Model.)

3 Sheets—Sheet 3.

R. M. DIXON.
STEAM HEATING APPARATUS.

No. 523,962.

Patented July 31, 1894.

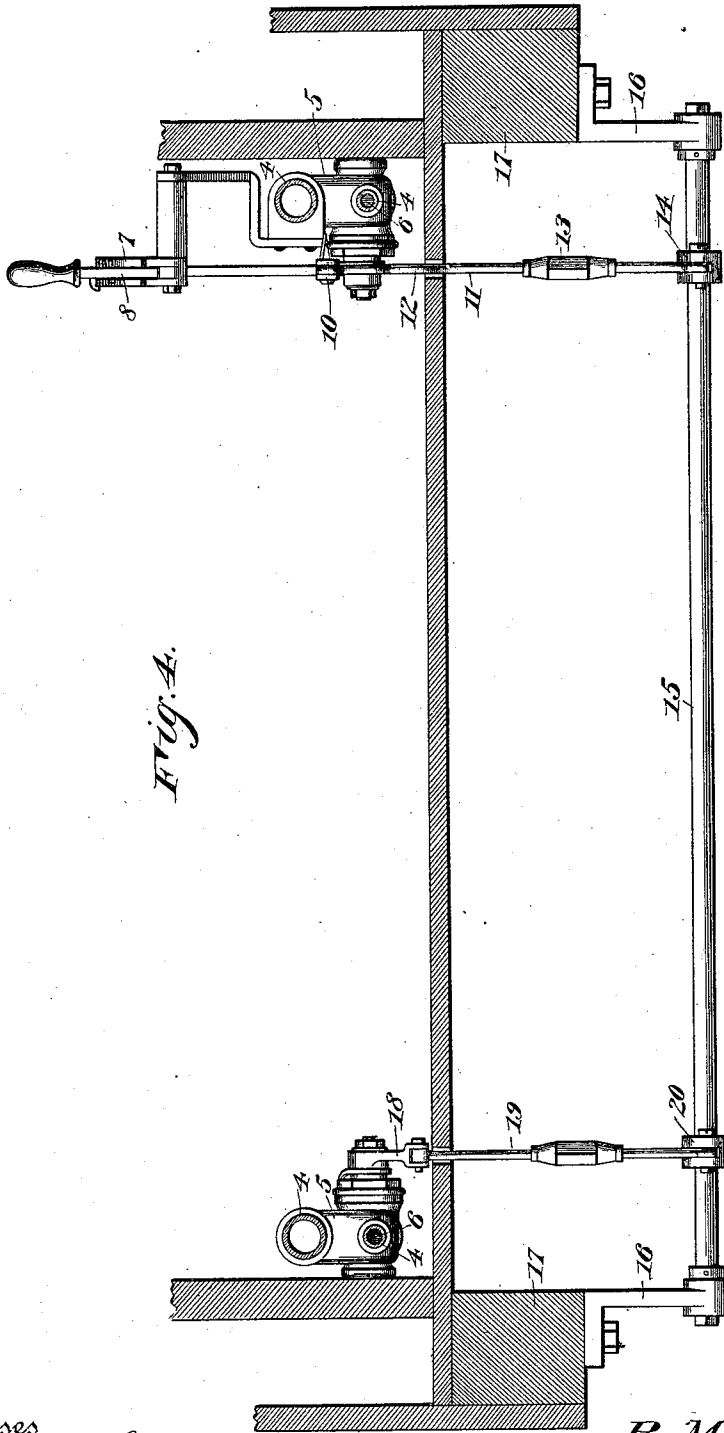

Fig. 4.

Witnesses

J. M. Litherow
et al.

Inventor,
R. M. Dixon

By *Stephen K. Atkins*
Attorney

UNITED STATES PATENT OFFICE.

ROBERT MUNN DIXON, OF EAST ORANGE, NEW JERSEY.

STEAM HEATING APPARATUS.

SPECIFICATION forming part of Letters Patent No. 523,962, dated July 31, 1894.

Application filed October 18, 1892. Serial No. 449,266; (No model.)

To all whom it may concern:

Be it known that I, ROBERT MUNN DIXON, of East Orange, county of Essex, and State of New Jersey, have invented certain new and useful Improvements in Steam Heating Apparatus, of which the following is a specification, reference being had to the accompanying drawings.

The object of my invention is to produce means for simultaneously regulating the flow of steam into the local heating pipes of a car heating system from the main supply pipe.

Heretofore it has been necessary to give attention to a number of different radiator valves, and to regulate them with respect to each other, which in practice proves a considerable inconvenience.

By my invention I provide means for operating all the valves of a system of radiators from one point by a single lever, at the same time controlling the steam supply to the different radiator pipes of a local heater as may be necessary to suit different temperatures.

In the accompanying drawings, Figure 1 is a top plan view of my apparatus as applied to a car, the car being omitted. Fig. 2 is a longitudinal sectional view of the same and Fig. 3 is a side elevation of a portion of my apparatus. Fig. 4, is an enlarged view of the valve operating mechanism. Fig. 5, is a view illustrating the construction of the valves whereby the movement of the actuating lever may open them to a greater or lesser degree.

Referring to the figures on the drawings, 1 indicates a main supply pipe, which is preferably located underneath the car floor, and is in practice connected with a source of steam, not illustrated.

2 indicates branch supply pipes, and 3 suitable cocks in the main pipe on opposite sides of the branch pipes, as usual.

4 indicates radiators, which may be arranged on opposite sides of the car, substantially as shown in my Patent No. 435,484 for example.

It is desirable in heating by such an apparatus to be able to control the supply of steam into the radiators, so that the radiating surface may be increased or diminished as required. For this purpose I employ an intermediate valve casting 5 for each local heater.

The valve casting is adapted to establish communication between the separate radiating pipes of the local heater, and is provided with a valve 6 of any suitable and ordinary construction adapted to completely close the radiator or to gradually open it to its full heating capacity.

7 indicates a notched quadrant adapted to be secured on one of the sides of a car above the valve, as for example by fastening it to the side of the car.

8 indicates a lever operatively connected at one end to the valve and carrying on its other end a spring pawl 9 adapted to engage with the notches in the quadrant to hold the lever in a fixed position. The valves on the opposite sides of the car are operatively connected together so as to be controlled by the lever 8. Suitable mechanism for accomplishing this result is illustrated in the drawings, in which 10 indicates a lug upon one side of the lever, to which is pivotally fastened a pitman 11 which is provided with a bend 12 to overlap the hub of the valve and allow the lever full swing.

13 indicates an extension nut for regulating the length of the pitman, the body of the pitman being divided, as usual, for the purpose. The lower end of the pitman is pivotally connected to a lever 14, which is fastened to one end of a shaft 15 which is carried in suitable bearings 16, preferably fastened to the bottoms of the side sills 17.

18 indicates another lever fastened to the shaft and pivotally connected with an extensible pitman 19, which is pivotally connected with a lever 10 at its opposite end, which is operatively fastened to the other valve 6. By the correlative adjustment of the pitmen the valves may be operated in different degrees, the well known construction of these valves obviously permitting a partial rotation of the plugs without opening the passage there-through. By this means a further reduction of the radiating surface in the heating apparatus may be made. The shaft may be squared at its outer ends, as illustrated, for the purpose of operating the valves by a crank from the outside when desired. I wish it to be understood in this connection that I do not limit myself to the details of construction herein

illustrated and described, but reserve the right to vary them at will within the scope of my invention.

What I claim is—

5 1. In a steam heating apparatus, the combination with a steam supply pipe and a plurality of radiators communicating therewith, through separate pipes, of valves controlling the supply of steam through the pipes and
10 the radiators, a shaft, levers upon the valves and upon the shaft, respectively, and extensible pitmen connecting the said levers, substantially as and for the purpose specified.

15 2. In a car heating apparatus, the combination with a steam supply pipe, and separate

radiators communicating therewith, of valves controlling the steam supply to the radiators, a single lever operatively connected with the several valves, and means for simultaneously operating the valves in different degrees to
20 supply steam in different quantities to the several radiators, respectively, by the movement of the lever, substantially as specified.

In testimony of all which I have hereunto subscribed my name.

ROBERT MUNN DIXON.

Witnesses:

ROBERT P. BROWN,
OSCAR C. WHITNEY.