

(19) **DANMARK**



Patent- og
Varemærkestyrelsen

(10) **DK/EP 3402200 T3**

(12) **Oversættelse af
europæisk patentskrift**

- (51) Int.Cl.: **H 04 N 19/176 (2014.01)** **H 04 N 19/11 (2014.01)** **H 04 N 19/124 (2014.01)**
H 04 N 19/157 (2014.01) **H 04 N 19/196 (2014.01)** **H 04 N 19/44 (2014.01)**
H 04 N 19/463 (2014.01) **H 04 N 19/593 (2014.01)** **H 04 N 19/60 (2014.01)**
- (45) Oversættelsen bekendtgjort den: **2023-04-24**
- (80) Dato for Den Europæiske Patentmyndigheds bekendtgørelse om meddelelse af patentet: **2022-11-23**
- (86) Europæisk ansøgning nr.: **18181670.3**
- (86) Europæisk indleveringsdag: **2012-04-20**
- (87) Den europæiske ansøgnings publiceringsdag: **2018-11-14**
- (30) Prioritet: **2011-10-24 KR 20110108460** **2011-10-24 KR 20110108456**
- (62) Stamansøgningsnr: **12843637.5**
- (84) Designerede stater: **AL AT BE BG CH CY CZ DE DK EE ES FI FR GB GR HR HU IE IS IT LI LT LU LV MC MK MT NL NO PL PT RO RS SE SI SK SM TR**
- (73) Patenthaver: **Gensquare LLC, 2nd Floor, Dongrim Building, 38 , Gangnam-daero 62-gil, Gangnam-gu, Seoul, 06254, Sydkorea**
- (72) Opfinder: **PARK, Shin Ji, 103-1301 Boramae Parkvill, 711 Sindaebang 2-dong, Dongjak-gu, 156-855 Seoul, Sydkorea**
- (74) Fuldmægtig i Danmark: **AWA Denmark A/S, Strandgade 56, 1401 København K, Danmark**
- (54) Benævnelse: **BILLEDEKODNINGSAPPARAT**
- (56) Fremdragne publikationer:
WIEGAND T ET AL: "Overview of the H.264/AVC video coding standard", IEEE TRANSACTIONS ON CIRCUITS AND SYSTEMS FOR VIDEO TECHNOLOGY, IEEE SERVICE CENTER, PISCATAWAY, NJ, US, vol. 13, no. 7, 1 July 2003 (2003-07-01), pages 560-576, XP011221093, ISSN: 1051-8215, DOI: 10.1109/TCSVT.2003.815165
KOBAYASHI M ET AL: "CE4 Subtest 2: Delta QP prediction results of test 2.2.b and 2.3.f", 97. MPEG MEETING; 18-7-2011 - 22-7-2011; TORINO; (MOTION PICTURE EXPERT GROUP OR ISO/IEC JTC1/SC29/WG11),, no. m20721, 1 July 2011 (2011-07-01), XP030049284,
T-D CHUANG ET AL: "Luma Intra Prediction Mode Coding", 6. JCT-VC MEETING; 97. MPEG MEETING; 14-7-2011 - 22-7-2011; TORINO; (JOINT COLLABORATIVE TEAM ON VIDEO CODING OF ISO/IEC JTC1/SC29/WG11 AND ITU-T SG.16); URL: HTTP://WFTP3.ITU.INT/AV-ARCH/JCTVC-SITE/,, no. JCTVC-F062, 1 July 2011 (2011-07-01), XP030009085,

DESCRIPTION

Technical Field

[0001] The present invention relates to an image decoding device, and more particularly, to a device that uses quantization parameters of left and top coding units to derive a quantization parameter predictor used for generating a residual block.

Background Art

[0002] Image data has to be encoded to efficiently store or transmit the image data. MPEG-1, MPEG-2, MPEG-4, H.264/MPEG-4 AVC (Advanced Video Coding), and the like are known as techniques of encoding image data. In these techniques, a picture is divided into macro blocks, it is determined which of intra encoding or inter encoding should be performed in the unit of the macro blocks, and the macro blocks are encoded using the determined encoding method.

[0003] In H.264 which is a latest image compressing technique, intra prediction is performed to enhance the efficiency of the intra encoding. That is, instead of referring to a reference picture to encode a current block, a prediction block is created using pixel values spatially neighboring the current block to be encoded. Specifically, an intra prediction mode having a small distortion is selected through comparison with an original macro block using the neighboring pixel values and the prediction block of the current block to be encoded is created using the selected intra prediction mode and the neighboring pixel values. A residual block including difference signals between the current block and the prediction block is created and the residual block is transformed, quantized, and entropy-encoded. The intra prediction mode used to create the prediction block is also encoded.

[0004] However, in H.264, the intra prediction mode of a current block is encoded regardless of directivity of the intra prediction modes of the left and top blocks of the current block and there is thus a problem in that the encoding efficiency is low. When the number of intra prediction modes increases to enhance the encoding efficiency of a residual block, there is a need for an intra prediction encoding method having efficiency higher than that of the intra prediction mode encoding method of H.264.

[0005] When coding units having various sizes are allowed unlike in H.264, a quantization parameter can be adaptively changed to improve encoding efficiency of a texture. However, in this case, a large number of bits are required to transmitting the quantization parameter. Therefore, there is a need for a method capable of effectively reducing the number of bits.

[0006] Weigand T et al; "Overview of the H.264/AVC video coding standard", IEEE Transactions on Circuits and Systems for Video Technology; IEEE Service Center, Piscataway,

NJ, US, vol 13, no. 7, 1 July 2003 discloses the video coding standard of the ITU-T Video Coding Experts Group and the ISO/IEC Moving Picture Experts Group.

[0007] Kobayashi M et al: "CE4 Subtest 2: Delta QP Prediction Results of Test 2.2.b and 2.3.f", 97. MPEG Meeting: 18-7-2011 - 22-7-2011; Torino; (Motion Picture Expert Group of ISO/EIC JTC1/SC29/WG11), no. m20721, 1 July 2011 discloses the experimental results of QP prediction techniques based on CU depth and prediction modes, which are test 2.2.b and test 2.3.f of CE4 Subtest2. These technologies were originally presented in the contribution of JCTVC-E198 at the 5th JCT-VC meeting, and they introduced depth-dependent QP prediction (2.2.b) and the prediction mode dependent QP prediction (2.3.f) respectively.

[0008] T-D Chuang et al: "Luma Intra Prediction Mode Coding", 6. JCT-VC Meeting; 97. MPEG Meeting; 14-7-2011 - 22-7-2011; Torino; (Joint Collaborative Team on Video Coding of ISO/IEC JCT1/SC29/WG11 and ITU-T SG. 16), no. JCTVC-F062, 1 July 2011 discloses a luma intra prediction mode coding method. As in IIM-3.0, a current intra prediction mode was first checked to see if it is equal to a most probable mode (MPM) derived from its left block and upper block. When the current intra prediction mode was not equal to any MPM, at most three most probable remaining modes (MPRMs) according to the intra modes of neighboring blocks could be used. When the current intra prediction mode is not equal to any MPM or MPRM, one of the remaining modes was signaled to indicate the current intra prediction mode. Simulation results reportedly showed 0.4% bit rate reduction in the high efficiency all intra condition with 2% encoding time increase and 1% decoding time increase.

[0009] It is therefore the object of the invention to provide an improved apparatus for decoding image.

[0010] This object is solved by the subject matter of the independent claims

[0011] Preferred embodiments are defined by the dependent claims.

Technical Problem

[0012] An object of the invention is to provide a device which can improve image quality by adaptively adjusting a quantization parameter of a current block depending on the size of a coding unit and enhance compression efficiency and decompression efficiency of an image by effectively encoding/decoding the quantization parameter to reduce the number of bits required for transmitting the quantization parameter.

Solution to Problem

[0013] According to an aspect of the invention, there is provided an image decoding device

including: an intra prediction module for reconstructing an intra prediction mode and creating a prediction block of a current block or a sub block of the current block; an inverse scanning module for converting residual signals into a two-dimensional quantization block; an inverse quantization module for inversely quantizing the quantization block using the quantization parameter; and an inverse transform module for inversely-transforming the inversely-quantized block. A quantization parameter predictor used for deriving the quantization parameter is created using a quantization parameter of a left coding unit of a current coding unit and a quantization parameter of a top coding unit of the current coding unit.

[0014] In the image decoding device, the quantization parameter is reconstructed by adding the quantization parameter predictor to a received residual quantization parameter, and the quantization parameter predictor is set as an average value of the quantization parameter of the left coding unit and the quantization parameter of the top coding unit.

[0015] In the image decoding device, the intra prediction module constructs an MPM group including three intra prediction modes using intra prediction modes of a left and top blocks of the current block, and reconstructs the intra prediction mode of the current block using the MPM group and a received intra prediction information. Also, the MPM group includes a planar mode, a DC mode and a vertical mode when the intra prediction modes of the left and the top block of the current block are invalid.

Advantageous Effects

[0016] The image decoding device according to the invention includes an intra prediction module for reconstructing an intra prediction mode and creating a prediction block of a current block or a sub block of the current block, an inverse scanning module for converting residual signals into a two-dimensional quantization block, an inverse quantization module for inversely quantizing the quantization block using the quantization parameter, and an inverse transform module for inversely-transforming the inversely-quantized block. A quantization parameter predictor used for deriving the quantization parameter is created using a quantization parameter of a left coding unit of a current coding unit and a quantization parameter of a top coding unit of the current coding unit.

[0017] Therefore, it is possible to improve image quality by adaptively adjusting a quantization parameter of a current block depending on the size of a coding unit and to enhance compression efficiency of an image by effectively encoding/decoding the quantization parameter to reduce the number of bits required for transmitting the quantization parameter.

Brief Description of the Drawings

[0018]

FIG. 1 is a block diagram illustrating a moving image encoding device

FIG. 2 is a block diagram illustrating a moving image decoding device

FIG. 3 is a diagram illustrating a method of creating an intra prediction block in the moving image decoding device.

FIG. 4 is a conceptual diagram illustrating intra prediction modes..

FIG. 5 is a block diagram illustrating an intra prediction block creating unit 300.

FIG. 6 is a block diagram illustrating a residual block reconstructing sequence.

FIG. 7 is a block diagram illustrating a residual block reconstructing sequence.

Description of Examples

[0019] Hereinafter, various examples of the invention will be described in detail with reference to the accompanying drawings.

In description of the invention with reference to the drawings, like constituents are referenced by like reference numerals.

[0020] A moving image encoding device and a moving image decoding device according to the invention may be user terminals such as a personal computer, a notebook PC, a personal digital assistant, a portable multimedia player, a smart phone, a wireless communication terminal, and a TV or servers providing services. The moving image encoding device and the moving image decoding device may be apparatuses having a communication device such as a communication modem for communicating with various apparatuses or wireless or wired communication networks, a memory storing various programs and data for encoding and decoding an image, and a microprocessor performing the programs to perform operations and controls.

[0021] FIG. 1 is a block diagram illustrating a moving image encoding device.

[0022] The moving image encoding device 100 includes an intra prediction module 110, an inter prediction module 120, a transform and quantization module 130, an entropy encoding module 140, an inverse quantization and inverse transform module 150, a post-processing module 160, a picture buffer 170, a subtraction module 190, and an addition module 195.

[0023] The intra prediction module 110 creates an intra prediction block using reconstructed pixels of a picture or slice to which a current block belongs. The intra prediction module 110 selects one of a predetermined number of intra prediction modes depending on the size of the

current block to be prediction-encoded and creates a prediction block depending on the selected intra prediction mode.

[0024] The inter prediction module 120 performs a motion estimation operation using reference pictures stored in the picture buffer 170 and determines reference picture indices and motion vectors for the motion estimation operation. Then, the inter prediction module 120 creates an inter prediction block of the current block using the reference picture indices and the motion vectors.

[0025] The transform and quantization module 130 transforms and quantizes a residual block of the prediction block created by the intra prediction module 110 or the inter prediction module 120. The transform is performed using one-dimensional transform matrixes in the horizontal and vertical directions. The residual block for intra prediction is transformed using transform matrixes determined depending on the size of the transform block (that is, the size of the residual block) and the intra prediction mode. The residual block for inter prediction is transformed using predetermined transform matrixes.

[0026] The transform and quantization module 130 quantizes the transform block using a quantization step size. The quantization step size can be changed by coding units equal to or larger than a predetermined size.

[0027] The quantized transform block is supplied to the inverse quantization and inverse transform module 150 and the entropy encoding module 140.

[0028] The inverse quantization and inverse transform module 150 inversely quantizes the quantized transform block and inversely transform the inversely-quantized transform block to reconstruct the residual block. The addition module adds the residual block reconstructed by the inverse quantization and inverse transform module 150 and the prediction block from the intra prediction module 110 or the inter prediction module 120 to create a reconstructed block.

[0029] The post-processing module 160 serves to improve image quality of the reconstructed picture and includes a deblocking filter module 161, an offset module 162, and a loop filter module 163.

[0030] The deblocking filter module 161 adaptively applies a deblocking filter to boundaries of the prediction block and the transform block. The boundaries can be limited to boundaries of 8x8 grids. The deblocking filter module 161 determines the boundaries to be filtered, determines boundary strengths thereof, and determines whether the deblocking filter should be applied to the boundaries when the boundary strength is larger than 0. When it is determined that the boundaries should be filtered, the deblocking filter module 161 selects a filter to be applied to the boundaries and filters the boundaries with the selected filter.

[0031] The offset module 162 determines whether an offset should be applied by pictures or slices so as to reduce the distortion between a pixel in the image undergoing the deblocking

filter module and a corresponding original pixel. Alternatively, a slice is divided into plural offset areas and the offset type of each offset area can be determined. The offset type may include a predetermined number of edge offset types and band offset types. When the offset type is an edge offset type, the edge type to which each pixel belongs is determined and an offset corresponding thereto is applied. The edge type is determined on the basis of the distribution of two pixel values neighboring a current pixel.

[0032] The loop filter module 163 adaptively loop-filters the reconstructed image on the basis of the comparison result of the reconstructed image undergoing the offset module 162 with the original image. It is determined whether the reconstructed image should be loop-filtered by coding units. The size and coefficients of the loop filter to be applied may be changed by the coding units. Information indicating whether the adaptively loop filter should be applied by coding units may be included in each slice header. In case of a chroma signal, it can be determined whether the adaptive loop filter should be applied by pictures. Therefore, information indicating whether chroma components are filtered may be included in a slice header or a picture header.

[0033] The picture buffer 170 receives post-processed image data from the post-processing module 160 and reconstructs and stores an image in the unit of pictures. The picture may be an image in the unit of frames or an image in the unit of fields.

[0034] The entropy encoding module 140 entropy-encodes the quantization coefficient information quantized by the transform and quantization module 130, the intra prediction information received from the intra prediction module 140, the motion information received from the inter prediction unit 150, and the like. The entropy encoding module 140 includes a scanning module 145 which is used to transform coefficients of the quantized transform block into one-dimensional quantization coefficients.

[0035] The scanning module 145 determines a scanning type for transforming the coefficients of the quantized transform block into one-dimensional quantization coefficients. The scanning type may vary depending on a directional intra prediction mode and the size of a transform block. The quantization coefficients are scanned in the backward direction.

[0036] When the quantized transform block is larger than a predetermined size, the transform coefficients are divided into plural sub blocks and are scanned. The scanning types applied to the transform coefficients of the sub blocks are the same. The scanning types applied to the sub blocks may be a zigzag scan or may be the same scanning types as applied to the transform coefficients of the sub blocks.

[0037] FIG. 2 is a block diagram illustrating a moving image decoding device 200

[0038] The moving image decoding device 200 includes an entropy decoding module 210, an inverse quantization module 220, an inverse transform module 230, an intra prediction module 240, an inter prediction module 250, a post-

processing module 260, a picture buffer 270, and an addition module 280.

[0039] The entropy decoding module 210 decodes a received bit stream and separates the bit stream into intra prediction information, inter prediction information, quantization coefficient information, and the like therefrom. The entropy decoding module 210 supplies the decoded intra prediction information to the intra prediction module 240 and supplies the decoded inter prediction information to the inter prediction module 250. The entropy decoding module 210 includes an inverse scanning module 215 for inversely scanning the decoded quantization coefficient information.

[0040] The inverse scanning module 215 converts the quantization coefficient information into a two-dimensional quantization block. One of plural scanning types is selected for the conversion. The scanning type may vary depending on a directional intra prediction mode and the size of a transform block. The quantization coefficients are scanned in the backward direction. When the quantized transform block is larger than a predetermined size, the transform coefficients are divided into plural sub blocks and are scanned. The scanning types applied to the transform coefficients of the sub blocks are the same. The scanning types applied to the sub blocks may be a zigzag scan or may be the same scanning types as applied to the transform coefficients of the sub blocks.

[0041] The inverse quantization module 220 determines a quantization step size predictor of a current coding unit and adds the determined quantization step size predictor to the received residual quantization step size to reconstruct the quantization step size of the current coding unit. The inverse quantization module 220 inversely quantizes the quantization block using the quantization step size and the inverse quantization matrix. The quantization matrix is determined depending on the size of the quantization block and the prediction mode. That is, the quantization matrix is selected on the basis of at least one of the prediction mode of the current block and the intra prediction modes for the quantization block having a predetermined size.

[0042] The inverse transform module 230 inversely transforms the inversely-quantized transform block to reconstruct a residual block. The inverse transform matrix to be applied to the inverse quantization block can be determined depending on the prediction mode and the intra prediction mode.

[0043] The addition module 280 adds the prediction block created by the intra prediction module 240 or the inter prediction module 250 to the residual block reconstructed by the inverse transform module 230 to create a reconstructed block.

[0044] The intra prediction module 240 reconstructs the intra prediction mode of the current block on the basis of the intra prediction information received from the entropy decoding module 210. Then, the intra prediction module 240 creates a prediction block depending on the reconstructed intra prediction mode.

[0045] The inter prediction module 250 reconstructs the reference picture index and the motion vector on the basis of the inter prediction information received from the entropy decoding module 210. Then, the inter prediction module 250 creates a prediction block of the current block using the reference picture index and the motion vector. When motion compensation with decimal prediction is applied, the selected interpolation filter is applied to create the prediction block.

[0046] The operation of the post-processing module 260 is the same as the operation of the post-processing module 160 shown in FIG. 1 and thus will not be described again.

[0047] The picture buffer 270 stores the decoded image post-processed by the post-processing module 260 in the unit of pictures.

[0048] FIG. 3 is a diagram illustrating a method of creating an intra prediction block

[0049] First, the intra prediction information from the received bit stream is entropy-decoded (S110).

[0050] The intra prediction information includes the intra prediction mode group indicator and the prediction mode index. The intra prediction mode group indicator indicates whether the intra prediction mode of the current block belongs to an MPM group or a group other than the MPM group. The prediction mode index is information indicating a specific intra prediction mode in the intra prediction mode group indicated by the intra prediction mode group indicator.

[0051] The intra prediction mode group indicator can be received in the form of unsigned integer. In this case, the intra prediction mode group indicator can be used without being entropy-decoded. Alternatively, the intra prediction mode group indicator may be adaptively entropy-encoded depending on the type of a current slice. For example, the intra prediction mode group indicator may be entropy-encoded using contexts determined depending on the slice type. Therefore, the intra prediction mode group indicator may be decoded using the contexts determined depending on the type of the current slice. The entropy-encoding method of the prediction mode index varies depending whether the intra prediction mode belongs to the MPM group or not. Therefore, the prediction mode index is entropy-decoded using different methods. Specifically, when the intra prediction mode group indicator represents that the intra prediction mode of the current block belongs to the MPM group, the prediction mode index is binarized in a truncated Exp-Golomb code manner or a truncated unary manner and is then entropy-encoded. Therefore, after the binary information is acquired by performing the entropy decoding, the prediction mode index is reconstructed using the above-mentioned methods. When the intra prediction mode group indicator represents that the intra prediction mode of the current block does not belong to the MPM group, the prediction mode index can be binarized with a fixed length. Therefore, after the binary information is acquired by performing the entropy decoding, the prediction mode index can be reconstructed.

[0052] Then, the MPM group is created using the intra prediction modes of the blocks

neighboring the current block and then the intra prediction mode of the current block is reconstructed using the MPM group (S120). The MPM group includes three intra prediction modes. This will be described with reference to FIG. 4. FIG. 4 is a diagram illustrating intra prediction modes.

1. (1) When the intra prediction modes of the top and left blocks of a current block are both present and are different from each other, the MPM group includes the two intra prediction modes and one additional intra prediction mode.

[0053] When one of the two intra prediction modes is a DC mode and the other is not a planar mode, the additional intra prediction mode may be the planar mode. Similarly, when one of the two intra prediction modes is the planar mode and the other is not the DC mode, the additional intra prediction mode may be the DC mode.

[0054] When the two intra prediction modes are the DC mode and the planar mode, the additional intra prediction mode may be a vertical mode or a horizontal mode.

[0055] When the two intra prediction modes are not the DC mode nor the planar mode, the additional intra prediction mode may be an intra prediction mode having directionality between the two intra prediction modes, or the DC mode or the planar mode.

[0056] (2) When the intra prediction modes of the top and left blocks of the current block are both present and are equal to each other, the MPM group includes the intra prediction mode and two additional intra prediction modes.

[0057] When the intra prediction mode is neither the DC mode nor the planar mode, the two additional intra prediction modes are set to two intra prediction modes neighboring the intra prediction mode. When the intra prediction mode is the DC mode, the two additional intra prediction modes may be the planar mode and the vertical mode.

[0058] (3) When only one of the intra prediction modes of the top and left blocks of the current block is present, the MPM group includes the intra prediction mode and two additional intra prediction modes. The two additional intra prediction modes are determined depending on the intra prediction mode.

[0059] (4) When the intra prediction modes of the top and left blocks of the current block are not present at all, the MPM group includes the DC mode, the planar mode, and the vertical mode.

[0060] When the intra prediction mode group indicator indicates the MPM group, the intra prediction mode indicated by the prediction mode index is selected from the MPM group and the selected intra prediction mode is determined as the intra prediction mode of the current block. The intra prediction mode group indicator may be flag information representing whether

the intra prediction mode of the current block belongs to the MPM group or a group other than the MPM group.

[0061] When the intra prediction mode group indicator does not indicate the MPM group, the intra prediction module 240 determines the intra prediction mode indicated by the prediction mode index out of the intra prediction modes (hereinafter, referred to as residual intra prediction modes) other than the intra prediction modes belonging to the MPM group as the intra prediction mode of the current block. The prediction mode indices assigned to the residual intra prediction modes vary depending on the configuration of the MPM group. That is, the decoded prediction mode indices indicate indices of the residual intra prediction modes rearranged depending on the configuration of the MPM group. Therefore, the intra prediction module 240 selects the intra prediction mode of the current block from the residual intra prediction modes depending on the decoded prediction mode index and the intra prediction modes belonging to the MPM group.

[0062] Specifically, the residual intra prediction modes of the current block are rearranged in the mode number order and the intra prediction mode corresponding to the received prediction mode index is selected as the intra prediction mode of the current block. In this case, the residual intra prediction modes may be rearranged, but the intra prediction mode of the current block may be determined by comparison of the intra prediction mode numbers belonging to the MPM group with the intra prediction mode index of the current block.

[0063] This method can be applied to a case where mode number 2 is assigned to the DC mode of the non-directional modes, mode number 34 is assigned to the planar mode, and directional mode numbers are assigned to the other modes. However, since the probability of selecting the planar mode and the DC mode as the intra prediction mode of the current is higher than those of the other directional modes, a small mode number (for example, mode number 0) is assigned to the planar mode and the above-mentioned method can be applied. In this case, the mode numbers of the other lower-ranked modes increase by 1.

[0064] Alternatively, the lowest indices may be assigned to the non-directional modes. For example, when the intra prediction mode of the current block is the planar mode and the residual intra prediction modes include the planar mode, the intra prediction mode index may include 0. For example, when the residual intra prediction modes include the planar mode and the DC mode, the intra prediction mode corresponding to the prediction mode index in a state where the planar mode, the DC mode, and the directional modes are arranged in this order may be set as the intra prediction mode of the current block. For example, mode number 0 and mode number 1 may be assigned to the planar mode and the DC mode, respectively, or mode number 0 and mode number 1 may be assigned to the DC mode and the planar mode, respectively. In this case, the intra prediction mode index of the current block may be compared with the intra prediction mode numbers belonging to the MPM group to determine the intra prediction mode of the current block.

[0065] Then, the size of the prediction block is determined using information indicating the

transform size of the current block (S130).

[0066] When the size of the prediction block is equal to the size of the current block, the prediction block is created using the intra prediction mode of the current block and the reference pixels of the current block. The reference pixels are pixels reconstructed or created previously to the current block.

[0067] When the size of the prediction block is smaller than the size of the current block, that is, when the current block can be divided into plural sub blocks and the intra prediction is performed thereon, the same intra prediction mode (that is, the intra prediction mode of the current block) is used to create the prediction block of each sub block. The prediction blocks of the second sub block or sub blocks subsequent thereto in the decoding order are created using the reconstructed pixels of the preceding sub blocks. Therefore, after the prediction block, the residual block, and the reconstructed block are created in the units of sub blocks, the prediction block of the next sub block is created.

[0068] Then, it is determined whether the reference pixels of the block corresponding to the size of the prediction block are all valid (S140). The reference pixels are pixels which are previously decoded and reconstructed. When it is determined that at least one of the reference pixels is not valid, the reference pixel is created (S150).

[0069] Specifically, when it is determined that the reference pixels are not valid at all, the reference pixel values are replaced with values of 2^{L-1} . Here, L represents the number of bits representing the gray scale of luma components.

[0070] When valid reference pixels are present in only one direction with respect to the position of the invalid reference pixel, the closest reference pixel out of the valid reference pixels is copied to create the reference pixels.

[0071] When valid reference pixels are present in both directions with respect to the position of the invalid reference pixel, the reference pixel located at the closest position in a predetermined direction can be copied or two closest reference pixels in both directions can be averaged to create the reference pixels.

[0072] Then, it is determined whether the reference pixels should be filtered (S160). The reference pixels are adaptively filtered depending on the reconstructed intra prediction mode and the size of the prediction block (S170).

[0073] The reference pixels are not filtered when the intra prediction mode is the DC mode. When the intra prediction modes are the vertical mode and the horizontal mode, the intra prediction module 240 does not also filter the reference pixels. However, when the intra prediction modes are directional modes other than the vertical mode and the horizontal mode, the reference pixels are adaptively filtered depending on the intra prediction mode and the size of the prediction block. When the size of the prediction block is 4x4, the reference pixels are

not filtered for the purpose of a decrease in complexity regardless of the intra prediction mode. The filtering serves to smooth the variation in pixel value between reference pixels and uses a low-pass filter. The low-pass filter may be [1, 2, 1] which is a 3-tap filter or [1, 2, 4, 2, 1] which is a 5-tap filter. When the size of the prediction block ranges from 8x8 to 32x32, the reference pixels are filtered in more intra prediction modes with an increase in the size of the prediction block.

[0074] Then, the prediction block is created depending on the intra prediction mode (S180). The reference pixels used for the prediction block may be pixels which are adaptively filtered depending on the size of the prediction block and the intra prediction mode.

[0075] In the DC mode, the average values of N top reference pixels located at positions of $(x=0, \dots, N-1, y=-1)$, M left reference pixels located at positions of $(x=-1, y=0, \dots, M-1)$, and the corner pixel located at a position of $(x=-1, y=-1)$ can be determined as the prediction pixels of the prediction block. However, the prediction pixels neighboring the reference pixels can be created using weighted average of the average value and the reference pixel neighboring the prediction pixel. In the planar mode, the prediction pixels can be created in the same way as in the DC mode.

[0076] In the vertical mode, the reference pixels located in the vertical direction are set to the prediction pixels. However, the prediction pixel neighboring the left reference pixel can be created using the reference pixel located in the vertical direction and the variation between the left reference pixels. The variation represents the variation between the corner reference pixel and the left reference pixel neighboring the prediction pixel. In the horizontal mode, the prediction pixels can be created in the same way as in the vertical mode, except for the direction.

[0077] FIG. 5 is a block diagram illustrating an intra prediction block creating unit 300.

[0078] The intra prediction block creating unit 300 according to the invention includes a parsing module 310, a prediction mode decoding module 320, a prediction block size determining module 330, a reference pixel validity determining module 340, a reference pixel creating module 350, a reference pixel filtering module 360, a prediction block creating module 370.

[0079] The parsing module 310 entropy-decodes a received bit stream to acquire intra prediction information and transform block size information.

[0080] The intra prediction information includes an intra prediction mode group indicator and a prediction mode index. The intra prediction mode group indicator represents which of an MPM group and a group other than the MPM group the intra prediction mode of a current block belongs to. The prediction mode index is information representing a specific intra prediction mode in the intra prediction mode group indicated by the intra prediction mode group indicator. The method of entropy-decoding the intra prediction information is the same as in step S110 of

FIG. 3.

[0081] The transform block size information includes at least one flag (`split_transform_flag`) which represents the transform block size and which is transmitted from an encoder.

[0082] The prediction mode decoding module 320 creates an MPM group using the intra prediction modes of blocks neighboring a current block and reconstructs the intra prediction mode of the current block using the MPM group and the entropy-decoded intra prediction information. The MPM group includes three intra prediction modes.

[0083] (1) When the intra prediction modes of the top and left blocks of a current block are both present and are different from each other, the MPM group includes the two intra prediction modes and one additional intra prediction mode.

[0084] When one of the two intra prediction modes is a DC mode and the other is not a planar mode, the additional intra prediction mode may be the planar mode. Similarly, when one of the two intra prediction modes is the planar mode and the other is not the DC mode, the additional intra prediction mode may be the DC mode.

[0085] When the two intra prediction modes are the DC mode and the planar mode, the additional intra prediction mode may be a vertical mode or a horizontal mode.

[0086] When the two intra prediction modes are not the DC mode nor the planar mode, the additional intra prediction mode may be an intra prediction mode having directionality between the two intra prediction modes, or the DC mode or the planar mode.

[0087] (2) When the intra prediction modes of the top and left blocks of the current block are both present and are equal to each other, the MPM group includes the intra prediction mode and two additional intra prediction modes.

[0088] When the intra prediction mode is neither the DC mode nor the planar mode, the two additional intra prediction modes are set to two intra prediction modes neighboring the intra prediction mode. When the intra prediction mode is the DC mode, the two additional intra prediction modes may be the planar mode and the vertical mode.

[0089] (3) When only one of the intra prediction modes of the top and left blocks of the current block is present, the MPM group includes the intra prediction mode and two additional intra prediction modes. The two additional intra prediction modes are determined depending on the intra prediction mode.

[0090] (4) When the intra prediction modes of the top and left blocks of the current block are not present at all, the MPM group includes the DC mode, the planar mode, and the vertical mode.

[0091] When the intra prediction mode group indicator indicates the MPM group, the intra prediction mode indicated by the prediction mode index is selected from the MPM group and the selected intra prediction mode is determined as the intra prediction mode of the current block. The intra prediction mode group indicator may be flag information representing whether the intra prediction mode of the current block belongs to the MPM group or a group other than the MPM group.

[0092] When the intra prediction mode group indicator does not indicate the MPM group, the intra prediction module 240 determines the intra prediction mode indicated by the prediction mode index out of the intra prediction modes (hereinafter, referred to as residual intra prediction modes) other than the intra prediction modes belonging to the MPM group as the intra prediction mode of the current block. The prediction mode indices assigned to the residual intra prediction modes vary depending on the configuration of the MPM group. That is, the decoded prediction mode indices indicate indices of the residual intra prediction modes rearranged depending on the configuration of the MPM group. Therefore, the intra prediction module 240 selects the intra prediction mode of the current block from the residual intra prediction modes depending on the decoded prediction mode index and the intra prediction modes belonging to the MPM group.

[0093] Specifically, the residual intra prediction modes of the current block are rearranged in the mode number order and the intra prediction mode corresponding to the received prediction mode index is selected as the intra prediction mode of the current block. In this case, the residual intra prediction modes may be rearranged, but the intra prediction mode of the current block may be determined by comparison of the intra prediction mode numbers belonging to the MPM group with the intra prediction mode index of the current block.

[0094] The MPM group constructing method can be applied to a case where mode number 2 is assigned to the DC mode of the non-directional modes, mode number 34 is assigned to the planar mode, and directional mode numbers are assigned to the other modes. However, since the probability of selecting the planar mode and the DC mode as the intra prediction mode of the current is higher than those of the other directional modes, a small mode number (for example, mode number 0) is assigned to the planar mode and the above-mentioned method can be applied. In this case, the mode numbers of the other lower-ranked modes increase by 1.

[0095] Alternatively, the lowest indices may be assigned to the non-directional modes. For example, when the intra prediction mode of the current block is the planar mode and the residual intra prediction modes include the planar mode, the intra prediction mode index may include 0. For example, when the residual intra prediction modes include the planar mode and the DC mode, the intra prediction mode corresponding to the prediction mode index in a state where the planar mode, the DC mode, and the directional modes are arranged in this order may be set as the intra prediction mode of the current block. For example, mode number 0 and mode number 1 may be assigned to the planar mode and the DC mode, respectively, or mode number 0 and mode number 1 may be assigned to the DC mode and the planar mode,

respectively. In this case, the intra prediction mode index of the current block may be compared with the intra prediction mode numbers belonging to the MPM group to determine the intra prediction mode of the current block.

[0096] The prediction block size determining module 330 determines the size of the prediction block of the current block using the block transform size. The size of the prediction block may have the size of the current block or the size of sub blocks of the current block.

[0097] When the size of the prediction block is equal to the size of the current block, the prediction block is created using the intra prediction mode of the current block and the reference pixels of the current block. The reference pixels are pixels reconstructed or created previously to the current block.

[0098] When the size of the prediction block is smaller than the size of the current block, that is, when the current block can be divided into plural sub blocks and the intra prediction is performed thereon, the same intra prediction mode (that is, the intra prediction mode of the current block) is used to create the prediction block of each sub block. The prediction blocks of the second sub block or sub blocks subsequent thereto in the decoding order are created using the reconstructed pixels of the preceding sub blocks. Therefore, after the prediction block, the residual block, and the reconstructed block are created in the units of sub blocks, the prediction block of the next sub block is created.

[0099] The reference pixel validity determining module 340 determines whether the reference pixels of the block corresponding to the size of the prediction block are all valid. The reference pixels are pixels which are previously decoded and reconstructed.

[0100] When it is determined that at least one of the reference pixels is not valid, the reference pixel validity determining module 340 creates the reference pixel.

[0101] Specifically, when it is determined that the reference pixels are not valid at all, the reference pixel values are replaced with values of 2^{L-1} . Here, L represents the number of bits representing the gray scale of luma components.

[0102] When valid reference pixels are present in only one direction with respect to the position of the invalid reference pixel, the closest reference pixel out of the valid reference pixels is copied to create the reference pixels.

[0103] When valid reference pixels are present in both directions with respect to the position of the invalid reference pixel, the reference pixel located at the closest position in a predetermined direction can be copied or two closest reference pixels in both directions can be averaged to create the reference pixels.

[0104] The reference pixel filtering module 360 determines whether the reference pixels should be filtered. The reference pixels are adaptively filtered depending on the reconstructed

intra prediction mode and the size of the prediction block.

[0105] The reference pixels are not filtered when the intra prediction mode is the DC mode. When the intra prediction modes are the vertical mode and the horizontal mode, the intra prediction module 240 does not also filter the reference pixels. However, when the intra prediction modes are directional modes other than the vertical mode and the horizontal mode, the reference pixels are adaptively filtered depending on the intra prediction mode and the size of the prediction block. When the size of the prediction block is 4x4, the reference pixels are not filtered for the purpose of a decrease in complexity regardless of the intra prediction mode. The filtering serves to smooth the variation in pixel value between reference pixels and uses a low-pass filter. The low-pass filter may be [1, 2, 1] which is a 3-tap filter or [1, 2, 4, 2, 1] which is a 5-tap filter. When the size of the prediction block ranges from 8x8 to 32x32, the reference pixels are filtered in more intra prediction modes with an increase in the size of the prediction block.

[0106] The prediction block creating module 370 creates the prediction block depending on the intra prediction mode. The reference pixels used for the prediction block may be pixels which are adaptively filtered depending on the size of the prediction block and the intra prediction mode.

[0107] In the DC mode, the average values of N top reference pixels located at positions of $(x=0, \dots, N-1, y=-1)$, M left reference pixels located at positions of $(x=-1, y=0, \dots, M-1)$, and the corner pixel located at a position of $(x=-1, y=-1)$ can be determined as the prediction pixels of the prediction block. However, the prediction pixels neighboring the reference pixels can be created using weighted average of the average value and the reference pixel neighboring the prediction pixel. In the planar mode, the prediction pixels can be created in the same way as in the DC mode.

[0108] In the vertical mode, the reference pixels located in the vertical direction are set to the prediction pixels. However, each prediction pixel neighboring the left reference pixel can be created using the reference pixel located in the vertical direction and the variation between the left reference pixels. The variation represents the variation between the corner reference pixel and the left reference pixel neighboring the prediction pixel. In the horizontal mode, the prediction pixels can be created in the same way as in the vertical mode, except for the direction.

[0109] FIG. 6 is a block diagram illustrating a residual block reconstructing sequence.

[0110] A residual signal received in the unit of a current block or a sub block is decoded to create a two-dimensional quantization block (S210).

[0111] The quantization block is inversely quantized using a quantization parameter (S220).

[0112] The inversely-quantized block is inversely transformed to reconstruct a residual block

(S230).

[0113] FIG. 7 is a block diagram illustrating a quantization parameter reconstructing sequence. The quantization parameter reconstructing sequence can be performed by the inverse quantization unit 220 shown in FIG. 2.

[0114] A minimum CU size (hereinafter, referred to as a minimum minimum quantization CU size) enabling changing of the quantization parameter is reconstructed (S310).

[0115] The minimum quantization CU size can be signaled using one of the following methods.

[0116] In a first method, whether a QP should be changed in the unit of LCU or can be additionally changed in a sub CU thereof can be indicated using `cu_qp_delta_enabled_flag` included in a sequence parameter set. When the value of `cu_qp_delta_enabled_flag` is 1, that is, when the changing of QP_y in a CU smaller than the LCU is enabled, the minimum quantization CU size can be signaled using `max_cu_qp_delta_depth` included in a picture parameter set.

[0117] In a second method, the minimum quantization CU size is signaled using one information piece (`cu_qp_delta_depth`) through joint coding instead of transmitting both `cu_qp_delta_enabled_flag` and `max_cu_qp_delta_depth`. That is, information related to the minimum quantization CU size is not transmitted from the sequence parameter set, but the minimum quantization CU size is transmitted using `cu_qp_delta_depth` through the picture parameter set. Accordingly, it is possible to reduce the number bits required to transmit the information on the minimum quantization CU size and to adaptively adjust the size enabling changing of the quantization parameter by PPS, thereby improving encoding performance.

[0118] A quantization parameter predictor is calculated on the basis of the minimum quantization CU size (S320). The quantization parameter predictor can be created using the left quantization parameter of the current CU and the top quantization parameter of the current CU. For example, the average value of the left quantization parameter and the top quantization parameter can be set as the quantization parameter predictor.

[0119] The quantization parameter predictor and the received residual quantization parameter are added to reconstruct the quantization parameter (S330).

[0120] When the current CU is equal to or larger than the minimum quantization CU size, the quantization parameter of the current CU is reconstructed. However, when the current CU is smaller than the minimum quantization CU size, plural CUs included in the minimum quantization CU size have the same quantization parameter.

REFERENCES CITED IN THE DESCRIPTION

Cited references

This list of references cited by the applicant is for the reader's convenience only. It does not form part of the European patent document. Even though great care has been taken in compiling the references, errors or omissions cannot be excluded and the EPO disclaims all liability in this regard.

Non-patent literature cited in the description

- Overview of the H.264/AVC video coding standard **WEIGAND T et al.** IEEE Transactions on Circuits and Systems for Video Technology | IEEE Service Center, Piscataway 2003 0701 vol. 13, [0006]
- **KOBAYASHI M et al.** CE4 Subtest 2: Delta QP Prediction Results of Test 2.2.b and 2.3.f97. MPEG Meeting, 2011, [0007]
- **TORINO** Motion Picture Expert Group of ISO/IEC JTC1/SC29/WG11, 2011, m20721 [0007]
- **T-D CHUANG et al.** Luma Intra Prediction Mode Coding6. JCT-VC Meeting; 97. MPEG Meeting, 2011, [0008]
- **TORINO** Joint Collaborative Team on Video Coding of ISO/IEC JCT1/SC29/WG11 and ITU-T SG. 16, 2011, [0008]

P A T E N T K R A V

1. Apparat til dekodning af billeder, hvilket apparat omfatter:

et intraforudsigelsesmodul (240) til generering af en forudsigelsesblok ved anvendelse af en intraforudsigelsestilstand af en aktuel blok;

5 et inversscanningsmodul til generering af en kvantiseringsblok ved hjælp af inversscanningskvantiseringskoefficientinformation opnået fra en modtaget bitstrøm, hvor en scanningstype, der bruges til invers scanning, bestemmes ud fra intraforudsigelsestilstanden af den aktuelle blok;

et inverskvantiseringsmodul (220) til invers kvantisering af kvantiseringsblokken under anvendelse af en kvantiseringsparameter;

10 et inverstransformationsmodul (230) til invers transformation af den inverst kvantiserede blok for at konstruere en restblok; og

et additionsmodul (280) til at skabe en rekonstrueret blok ved at addere forudsigelsesblokken til restblokken,

15 hvor kvantiseringsparameteren genereres af inverskvantiseringsmodulet, ved at bruge en kvantiseringsparameter-prædiktør og en restkvantiseringsparameter, og kvantiseringsparameter-prædiktøren genereres ved brug af en kvantiseringsparameter af en venstre kodningsenhed og en kvantiseringsparameter for en øvre kodningsenhed af en aktuel kodningsenhed,

20 hvor intraforudsigelsestilstanden er udledt under anvendelse af en mest sandsynlig tilstands-, MPM, -gruppe konstrueret af intraforudsigelsesmodulet, en intraforudsigelsestilstandsgruppeindikator opnået fra bitstrømmen og et forudsigelsestilstandsindeks opnået fra bitstrømmen,

hvor en intraforudsigelsestilstand angivet ved forudsigelsestilstandsindekset i MPM-gruppen er bestemt som intraforudsigelsestilstanden for den aktuelle blok, når intraforudsigelsestilstandsgruppeindikatoren angiver brugen af MPM-gruppen,

25 hvor MPM-gruppen indbefatter 3 intraforudsigelsestilstande, som bestemmes ved anvendelse af tilgængelige intraforudsigelsestilstande for venstre og øvre naboblokke i den aktuelle blok,

hvor, når kun én af intraforudsigelsestilstandene af de venstre og øvre naboblokke af den aktuelle blok er tilgængelig, indbefatter MPM-gruppen den eneste tilgængelige intraforudsigelsestilstand for de venstre og øvre naboblokke af den aktuelle blok og to intraforudsigelsestilstande adderes dertil,

30 hvor MPM-gruppen indbefatter intraforudsigelsestilstandene af de venstre og øvre naboblokke af den aktuelle blok og en plan-tilstand, når en af intraforudsigelsestilstandene af de venstre og øvre naboblokke af den aktuelle blok er i DC-tilstand og den anden af intraforudsigelsestilstandene af de venstre og øvre naboblokke i den aktuelle blok ikke er en plan-tilstand, og

35 hvor MPM-gruppen indbefatter en plan-tilstand, DC-tilstand og vertikal-tilstand, når intraforudsigelsestilstanden for den venstre naboblok af den aktuelle blok er den samme som intraforudsigelsestilstanden for den øvre naboblok af den aktuelle blok, og intraforudsigelsestilstanden for den venstre naboblok af den aktuelle blok er en DC-tilstand.

2. Apparat ifølge krav 1, hvor kvantiseringsparameteren er genereret ved at addere kvantiseringsparameter-prædiktøren og differentialkvantiseringsparameteren.

3. Apparat ifølge krav 1, hvor kvantiseringsparameteren er indstillet som et gennemsnit af kvantiseringsparametrene for de venstre og øvre kodningsenheder af den aktuelle kodningsenhed, når begge kvantiseringsparametrene for de venstre og øvre kodningsenheder af den aktuelle kodningsenhed er tilgængelige.

5

4. Apparat ifølge krav 1, hvor MPM-gruppen indbefatter en plan-tilstand, DC-tilstand og vertikal-tilstand, når begge intraforudsigelsestilstande for de venstre og øvre naboblokke af den aktuelle blok ikke er tilgængelige.

5. Apparat ifølge krav 1, hvor størrelsen af forudsigelsesblokken bestemmes under anvendelse af oplysninger, der angiver en transformationsstørrelse.

10

6. Apparat ifølge krav 1, hvor, når intraforudsigelsestilstandene for de venstre og øvre naboblokke af den aktuelle blok ikke er lig med hinanden og er retningsbestemte intraforudsigelsestilstande, indbefatter MPM-gruppen intraforudsigelsestilstandene for de venstre og øvre naboblokke af den aktuelle blok og en plan-tilstand.

15

7. Apparat ifølge krav 1, hvor plan- og DC-tilstandene er ikke-retningsbestemte intraforudsigelsestilstande og tilstandsnummeret 0 er tildelt til plan-tilstanden.

DRAWINGS

FIG. 1

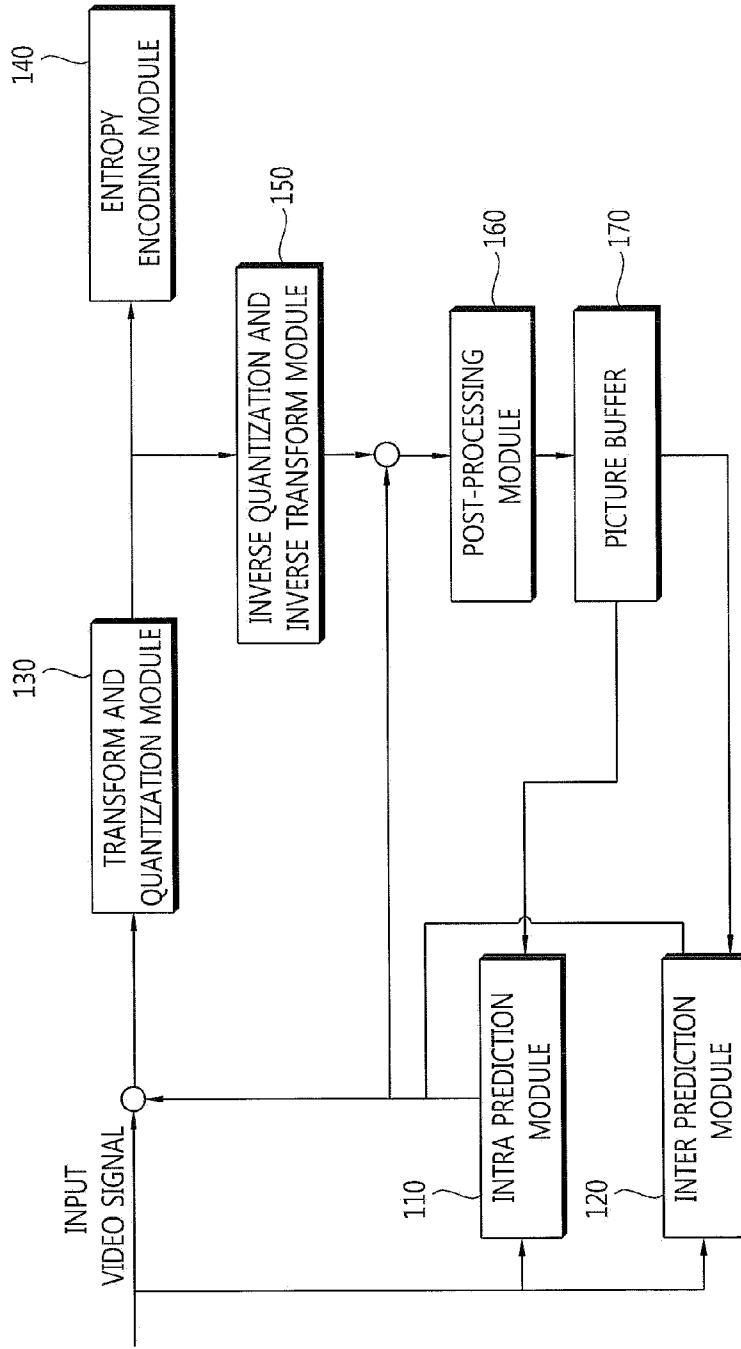

FIG. 2

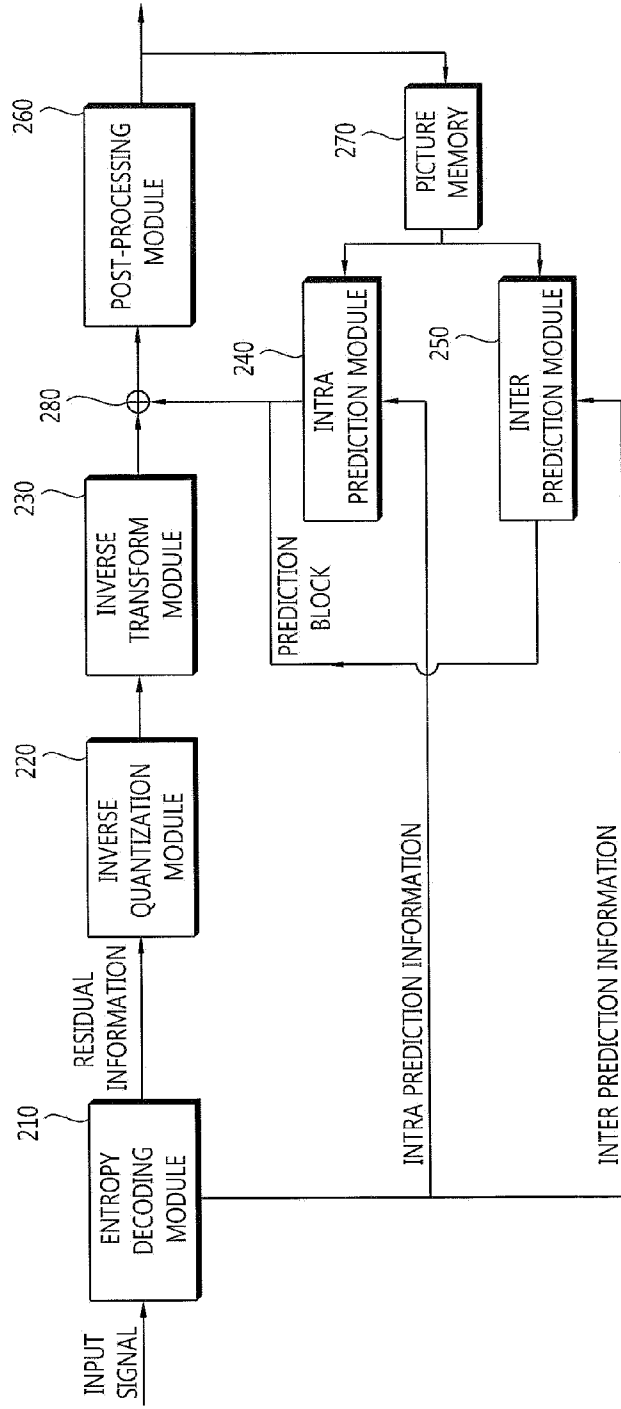

FIG. 3

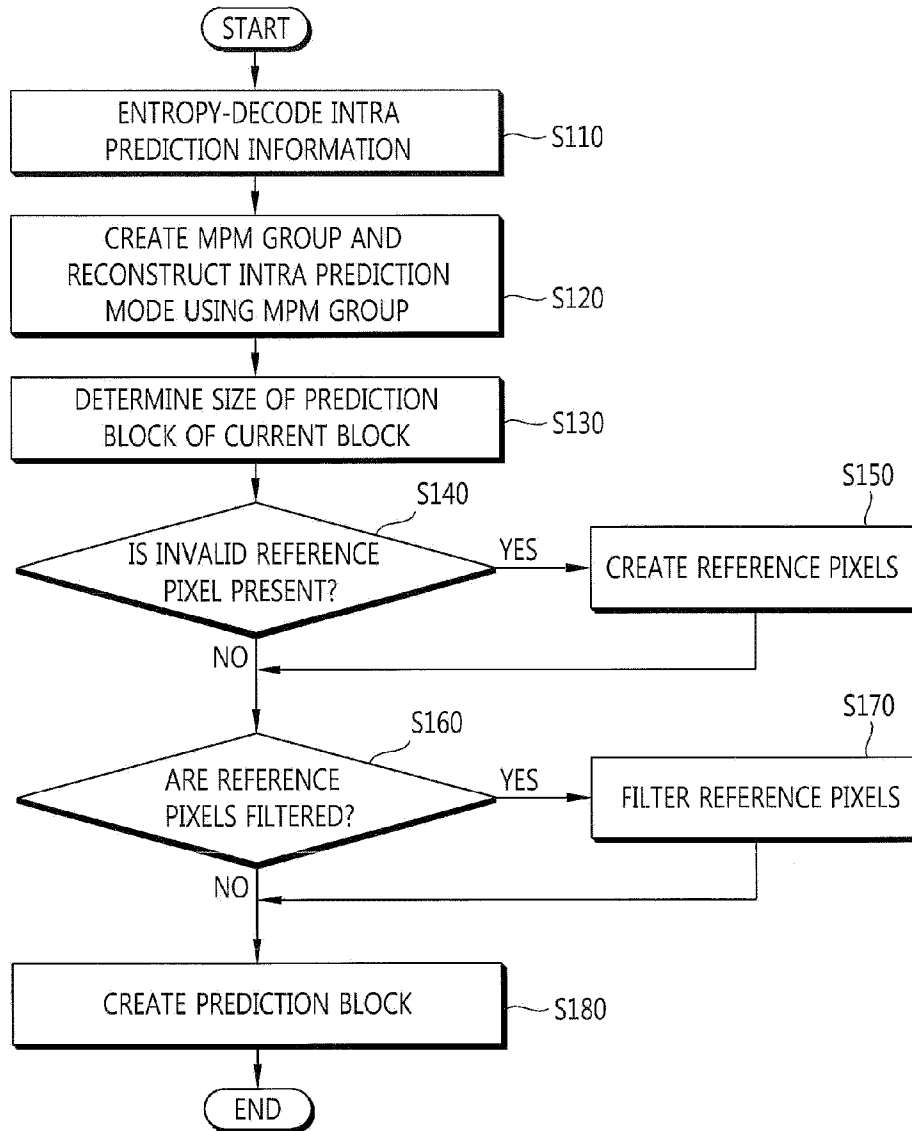

FIG. 4

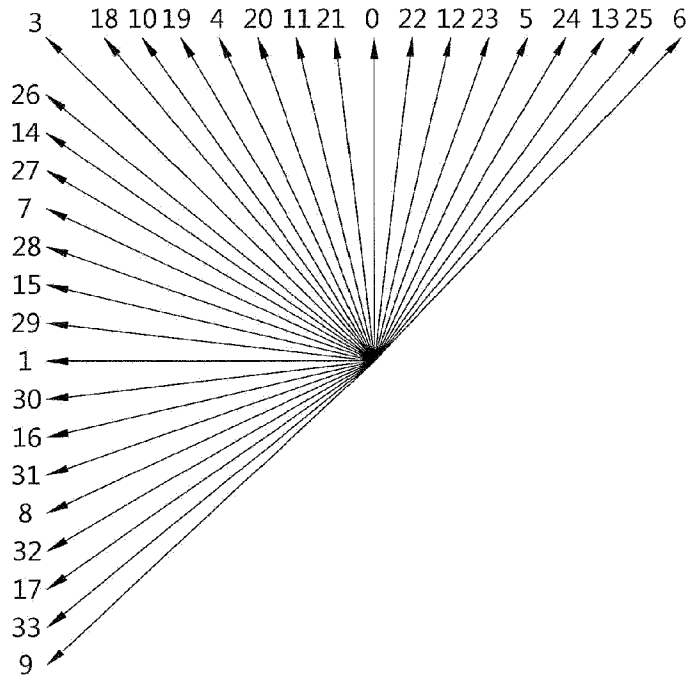

FIG. 5

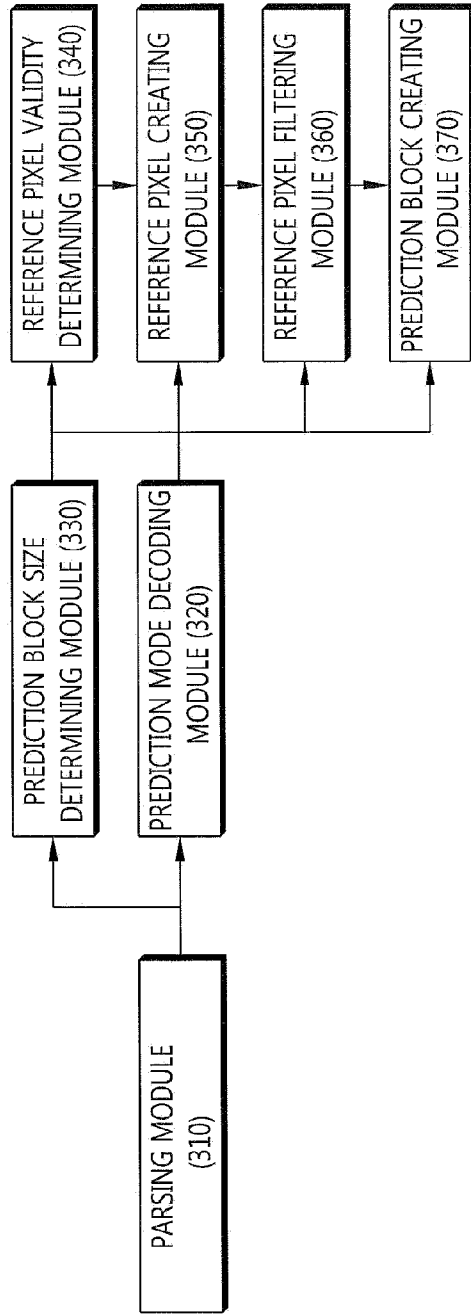

FIG. 6

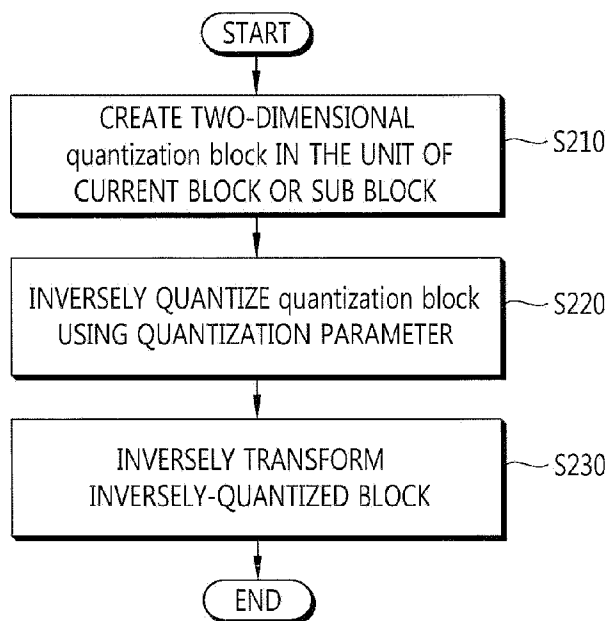

FIG. 7

