

J. N. DRAKE.
Track Clearer.

No. 105,185.

Patented July 12, 1870.

Fig. 1.

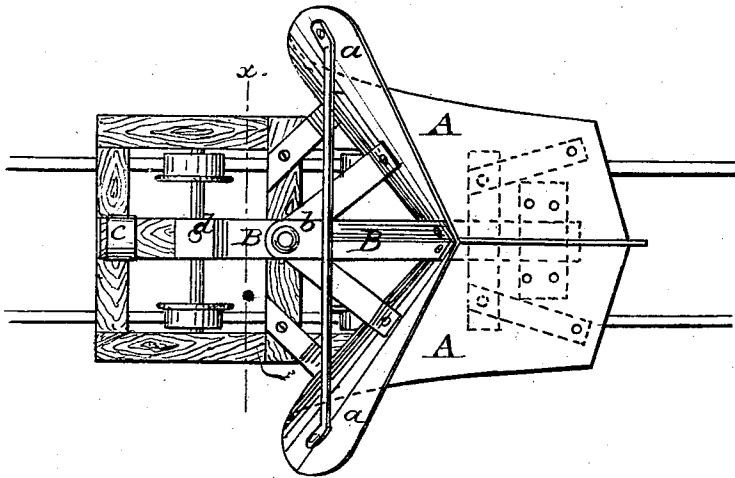
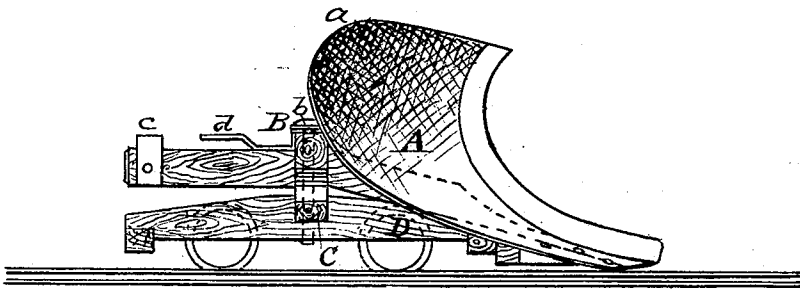

Fig. 2.



Witnesses:

Ad. Sellerle
Sam. J. Mart.

Inventor:

J. N. Drake
by Prindle & Selzer
Associates Attys.

J. N. DRAKE.
Track Clearer.

2 Sheets—Sheet 2.

No. 105,185.

Patented July 12, 1870.

Fig. 3.

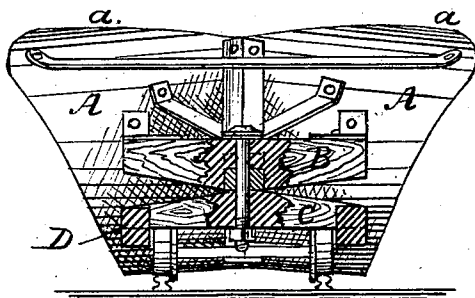
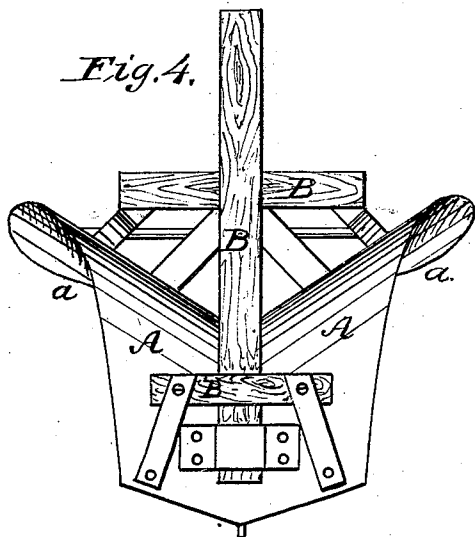

Fig. 4.



Witnesses:

M. M. Mather
Sam'l. W. Van

Inventor:

J. N. Drake
by *Printed & Co.*
Associates, Atty's.

United States Patent Office.

JASPER N. DRAKE, OF LIBERTY, MICHIGAN.

Letters Patent No. 105,185, dated July 12, 1870.

IMPROVEMENT IN SNOW-PLOW.

The Schedule referred to in these Letters Patent and making part of the same.

To whom it may concern :

Be it known that I, JASPER N. DRAKE, of Liberty, in the county of Jackson and State of Michigan, have invented a new and useful Improvement in Snow-Plow and Truck, combined; and I do hereby declare that the following is a true and accurate description thereof, reference being had to the accompanying drawing and to the letters of reference marked thereon, and being a part of this specification.

The nature of this invention relates to an improved construction of snow-plow and truck to be employed in clearing the tracks of railways, and consists in so attaching said plow to a proper truck that the plow may be reversed without the necessity of turning the truck.

Also, in the peculiar arrangement of the various parts to produce the effect desired.

In the accompanying drawing—

Figure 1 is plan view of my invention.

Figure 2 is a vertical longitudinal section of the same.

Figure 3 is a vertical cross-section of the same on the line xz of fig. 1, showing the rear of the plow and its attachments.

Figure 4 is a plan view of the bottom of the plow and attachments disconnected from the truck-frame.

Like letters denote like parts in each figure.

A represents a metallic plow, made preferably of boiler iron, with right and left wings or sections, the point or fore part of each wing being curved nearly to a horizontal line for the purpose of passing under and lifting the snow from the track.

The curve is continued upward and to the rear, as

shown at a , and thence upward and forward, making a deflecting curve, for the purpose hereinbefore described.

By means of any suitable braces and fastenings this plow is secured to a cross-shaped frame, B, through which, at the intersection of its timbers, passes a bolt, b , which also passes through the bolster C in such a manner as will allow the plow to be reversed, by rotating upon said bolt, without the necessity of turning the truck about upon a turn-table or otherwise.

The bolster C is rigidly secured transversely across the frame of the truck D, upon which the weight of the apparatus is carried.

The foot of the cross-shaped frame A should be provided with guide-strap c and coupling d , in order the more easily to secure to the apparatus the push or draw-bar of an engine or locomotive by means of which the plow and truck are propelled.

Immediately in front of each wheel of the truck may be secured a stiff broom or a small scraper, which should nearly touch the track, for the purpose of entirely clearing the rail of any snow which may be left in the passage of the plow.

What I claim as my invention, and desire to secure by Letters Patent, is—

Securing a snow-plow to a truck-frame so that the plow may be reversed upon the truck-frame and operated in the opposite direction, substantially as described, shown, and set forth.

JASPER N. DRAKE.

Witnesses:

H. S. SPRAGUE,
JAMES THIERRY.