



(51) International Patent Classification:

A61B 17/02 (2006.01) H02M 1/32 (2007.01)
A61B 1/32 (2006.01) H02M 1/44 (2007.01)

(21) International Application Number:

PCT/US2019/051549

(22) International Filing Date:

17 September 2019 (17.09.2019)

(25) Filing Language:

English

(26) Publication Language:

English

(30) Priority Data:

62/732,340 17 September 2018 (17.09.2018) US

(72) Inventors; and

(71) Applicants: **CESTERO, Ramon Francisco** [US/US]; c/o South Texas Research Facility, 8403 Floyd Curl Drive, STTM-MC 7746, San Antonio, Texas 78229 (US). **LONG, Justin Alexander** [US/US]; c/o South Texas Research Facility, 8403 Floyd Curl Drive, STTM-MC 7746, San Anto-

nio, Texas 78229 (US). **LONG, Clarence Lamar** [US/US]; c/o South Texas Research Facility, 8403 Floyd Curl Drive, STTM-MC 7746, San Antonio, Texas 78229 (US). **LONG, Jeffrey Adam** [US/US]; c/o South Texas Research Facility, 8403 Floyd Curl Drive, STTM-MC 7746, San Antonio, Texas 78229 (US).

(74) Agent: **LANDRUM, Charles**; 98 San Jacinto Blvd., Suite 1100, Austin, Texas 78701 (US).

(81) Designated States (unless otherwise indicated, for every kind of national protection available): AE, AG, AL, AM, AO, AT, AU, AZ, BA, BB, BG, BH, BN, BR, BW, BY, BZ, CA, CH, CL, CN, CO, CR, CU, CZ, DE, DJ, DK, DM, DO, DZ, EC, EE, EG, ES, FI, GB, GD, GE, GH, GM, GT, HN, HR, HU, ID, IL, IN, IR, IS, JO, JP, KE, KG, KH, KN, KP, KR, KW, KZ, LA, LC, LK, LR, LS, LU, LY, MA, MD, ME, MG, MK, MN, MW, MX, MY, MZ, NA, NG, NI, NO, NZ, OM, PA, PE, PG, PH, PL, PT, QA, RO, RS, RU, RW, SA,

(54) Title: ADJUSTABLE LOCKING SURGICAL RETRACTOR

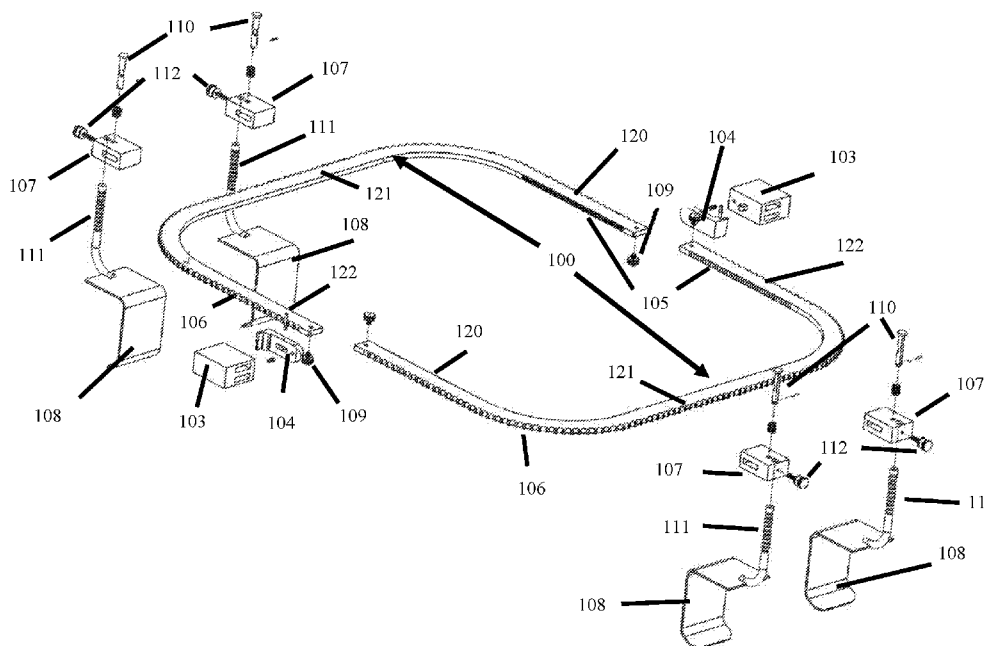

FIG. 1

(57) Abstract: A surgical retractor assembly for providing surgical exposure. The surgical retractor assembly consists of two frame segments connected by adjustable ratchet mechanisms to form a retractor frame. The ratchet mechanisms can be attached to tissue retractor blades that provide exposure of the wound when expanded, without the requirement of a direct connection/attachment to an operating table or bed frame. The tissue retractor blades are attached in a manner that is adjustable and facilitates the ability of the overall surgical retractor assembly to be raised or lowered with respect to the patient. The retractor frame also allows attachments of additional retractor blades or other surgical retractor accessories for additional surgical exposure.



SC, SD, SE, SG, SK, SL, SM, ST, SV, SY, TH, TJ, TM, TN,
TR, TT, TZ, UA, UG, US, UZ, VC, VN, ZA, ZM, ZW.

(84) Designated States (*unless otherwise indicated, for every kind of regional protection available*): ARIPO (BW, GH, GM, KE, LR, LS, MW, MZ, NA, RW, SD, SL, ST, SZ, TZ, UG, ZM, ZW), Eurasian (AM, AZ, BY, KG, KZ, RU, TJ, TM), European (AL, AT, BE, BG, CH, CY, CZ, DE, DK, EE, ES, FI, FR, GB, GR, HR, HU, IE, IS, IT, LT, LU, LV, MC, MK, MT, NL, NO, PL, PT, RO, RS, SE, SI, SK, SM, TR), OAPI (BF, BJ, CF, CG, CI, CM, GA, GN, GQ, GW, KM, ML, MR, NE, SN, TD, TG).

Published:

— *with international search report (Art. 21(3))*

ADJUSTABLE LOCKING SURGICAL RETRACTOR**PRIORITY PARAGRAPH**

[0001] This Application claims priority to U.S. Provisional Patent Application
5 62/732,340 filed September 17, 2018, which is incorporated herein by reference in its
entirety.

BACKGROUND

[0002] Abdominal operations in both emergency and elective surgery settings require
adequate exposure of abdominal contents in order for the surgeon to properly visualize areas
10 of injury or disease. This is typically accomplished by the use of static metal retractors. Two
of the most common retractor mechanisms in current use are the Balfour retractor and the
Bookwalter retractor. Each of these retractors presents advantages and disadvantages in their
design and use. The Balfour retractor consists of a frame with integrated metal blades on a
ratchet system which, when engaged, retracts the abdominal wall laterally, thereby exposing
15 the abdominal contents and allowing the surgeon to operate. The Bookwalter mechanism
consists of a supporting frame attached to the operating table upon which a rigid non-
adjustable metal ring is attached to which retractor blades are then attached individually.
Despite the ubiquitous use of these retractors, these surgical retractor mechanisms have not
been improved upon for considerable time.

20 [0003] The Balfour retractor is perhaps the most commonly utilized abdominal retractor
due its simple design, ease of use, and rapid exposure of the abdomen, particularly in trauma
and emergency surgery settings when time is of the essence. Since it does not require the
attachment of a metal frame to the operating room bed, as with the Bookwalter retractor,
valuable time is not wasted and it can be quickly inserted after the abdominal incision is
25 created.

[0004] Despite the Balfour retractor's prevalence in operating rooms and ease of
utilization, there are several limitations to its use. It provides inadequate abdominal exposure
of large or obese patients. In larger or obese patients, the current design of the standard
Balfour retractor often does not provide enough retraction to adequately expose the abdomen.
30 The frame along which the retractor blades run is typically too short for larger or obese

patients, resulting in suboptimal exposure and frequently necessitating conversion to another retractor system. Due to the Balfour retractor's inherently limited design, the surgical incision is only retracted along one axis (transverse), limiting overall exposure of the wound. An optional additional retractor blade (bladder blade) can be attached which only adds
5 retraction in the inferior direction, typically resulting in suboptimal exposure requiring conversion to another retractor system.

[0005] The standard Balfour retractor does not provide an additional frame upon which to attach additional retractor blades except for a single bladder blade. This significantly limits the ability to retract additional incisional or abdominal contents compared to other retractor
10 mechanisms, thereby limiting surgical exposure. Additionally, the Balfour retractor system commonly poses a significant problem during its use due to the unintentional movement and migration of the retractor blades along the edges of the surgical wound. The two retractor blades which provide lateral traction on the wound edges (or abdominal wall in abdominal operations) frequently unintentionally migrate to either the superior or inferior parts of the
15 wound, causing rotation of the entire retractor mechanism, loss of wound edge retraction, and requiring either time-consuming repositioning of the retractor or conversion to another type of retractor system. This is particularly common in large or obese patients.

[0006] Bookwalter retractor is typically the retractor system used when the Balfour retractor system is considered inadequate or ineffective. It consists of a supporting metal rod
20 which is attached to a side rail on the operating room table by a non-sterile individual in the operating room after the patient is under anesthesia (the rail on the operating table is not considered part of the sterile operating field). A second metal arm is then attached to this supporting rod, and a rigid circular or oblong metal ring is then attached to the second metal arm. Once this is in place, individual retractor blades can then be attached, using the rigid
25 ring for support.

[0007] Despite the popularity of the Bookwalter retractor it also presents several limitations. The Bookwalter retractor mechanism involves fixation to the operating room table which requires attachment by a non-sterile individual in the operating room. Occasionally this causes concerns in maintenance of the sterile field, as the surgeon may need
30 to place his hands below the sterile barrier in order to assist and properly place the retractor arm. In addition, the multiple arms which require setup before surgical retraction is achieved mandates a significant amount of time in instrument setup, rendering this system inadequate

for emergency settings or operations when time is of the essence. The circumferential ring used in the Bookwalter system is not expandable and frequently limits the placement of additional retractors in both the longitudinal and transverse axes. In addition, the fixed sizes of the rings do not allow adjustment of retraction depending on the individual physical characteristics of each patient and various types and sizes of wounds or incisions. The Bookwalter system also requires frequent repositioning by the surgical team during its use. After the Bookwalter system is set up and attached to the bed frame, the ring system is thereby fixed in place and additional retractors are attached. However, as the operation progresses and surgical exposure requirements change, the system needs to be repositioned to place the static non-expandable ring into the correct location. This requires interruption of the operation, removal of the retractor blades, repositioning of the ring, and reattachment of the retractor blades, again requiring significant time. There is an existing need for additional retractor systems.

SUMMARY

[0008] The current disclosure describes an adjustable retractor system that addresses many of the problems outlined above for current retractor systems, while minimizing the number of components. Certain embodiments are directed to a surgical retractor with a frame having an adjustable circumference or width comprising two interconnecting frame segments. In certain aspects the frame has fixed length along one axis and an adjustable length along the other perpendicular axis. In certain aspects the outer edge of the frame segments have a series of ridges forming teeth or grooves along at least a portion of the length, and in certain aspects along the entire length of the outer edge. The frame segment can have a stop mechanism positioned at one or both ends of the frame segment. In certain aspects, the stop can be anywhere along the length of the frame segment. The stop can be in the form of a screw, pin, hole, or elevated material that can contact or engage a connector to stop the movement of the frame segment through the connector which can result in disassembly or instability of the retractor. In certain aspects the stop is a screw that can engage threads formed in the frame segment. In certain respects a surgical retractor comprises (a) a retractor frame having an adjustable circumference or width comprising (i) two frame segments, each frame segment comprising a first and second substantially straight and substantially parallel arm portion connected by a middle portion that is substantially perpendicular the arm portions. The frame segments forms two curve portions that connect the arm portions to the

middle portion. Each frame segment having a top and bottom face with an inner edge and an outer edge, wherein the frame segments are configured to overlap with a first substantially straight arm portion of one frame segment overlapping a first substantially straight arm portion of the other frame segment, and (ii) connectors configured to receive arm portions of a first and/or second frame segment to form the retractor frame. The connector can be in (i) an unlocked configuration that allows the arm portions of the frame segments to move with respect to one another allowing the circumference of the frame to adjust or (ii) a locked configuration that fixes a first substantially straight arm portion of a first frame segment at a position relative to a first substantially straight arm portion of the second frame segment. In certain aspects, the connector can be affixed or removeably affixed to a frame segment. In a further aspect, a first and second connector can be affixed or removeably affixed to the same frame segment or different frame segments. In certain aspects, the connector(s) are affixed or removeably affixed to the end of a straight arm portion of a frame segment. In certain aspects, the arm portion of one frame segment is not the same as the arm portion of a second frame segment. In other aspects, the arm portions are of equal or similar length. The adjustable retractor can comprise 2, 3, 4, 5, 6 or more retractor blades coupled to the frame segments where the face of the retractor blade forms an angle with, e.g., is substantially perpendicular to, the plane of the frame. In certain aspects the connectors are designed to provide a ratchet mechanism. The ratchet mechanism of the connector is configured to interact with teeth or grooves that are positioned along all or a portion of the inner or outer edge of the frame segments. The connector can include 1, 2, 3, or more a pawls configured to engage one or more frame segment. In certain aspects, the connector comprises individual pawls configured to interact separately and/or independently with individual frame segments. In a further embodiment the connectors can be configured to provide a space between the frame segments faces. If there is space between the frame segments, this space can provide for the insertion of a portion of an attachment (e.g., a lip or protrusion on the attachment) to further stabilize additional attachments that may be affixed to the retractor. The ratchet mechanism allows the frame to be expanded when the connectors are in the locked position but does not allow the contraction of the frame unless a release is engaged. In certain aspects the ratchet mechanism associated with the connectors is a directional ratchet that allows a frame segment to move in one direction that results in expansion of the frame and resists or does not allow movement of the frame segment in the opposite direction, *i.e.*, frame contraction. In a further aspect the edges of the ratchet teeth or groove are beveled to allow for clearance of the ratchet. The connector(s) can further comprise one or more spring loaded brake mechanisms. In certain

aspects the retractor can be configured to be stabilized, coupled, or fixed to a subject's body, a wound, an incision, or a cavity. The retractor can be stabilized, coupled, or fixed by a clamp, suture, staple, or other mechanism. In certain aspects the retractor can have an adaptor or be fixed to an adaptor that in turn can be fixed to a support, such as a bed or
5 operating table.

[0009] In another embodiment a retractor blade is attached to a retractor blade connector. The retractor blade connector can be configured to allow the adjustment of the retractor blades up and down with respect to the frame segments or to be moved and secured along the frame segments. The retractor blade connector can form a passage through which the
10 proximal portion of the retractor blade can pass through. The passage being configured with a retractor blade locking mechanism that reversibly fixes the retractor blade at a particular position or depth. The locking mechanism can be a pin, a screw, or other locking mechanism that can reversibly engage the proximal portion of the retractor blade to hold it in place when engaged and allow its movement when disengaged. In certain aspects the locking mechanism
15 can include a spring to assist in engaging the mechanism and resisting the disengagement of the mechanism. In certain aspects the pin or screw can pass through an opening in the retractor blade connector body or be attached to the top or bottom of the retractor blade connector body. The proximal portion of the retractor blade can have an adjustment portion that passes through the retractor blade connector. The adjustment portion can have grooves,
20 holes, or teeth to engage the retractor blade locking mechanism. The connector can further comprise a removable stop coupled with a prescribed slot or pattern of holes formed in the frame segment that together are configured to reversibly lock the connector in place. In certain aspects, the connectors are configured to allow one or more frame segments to be expanded and do not allow one or more frame segments to be contracted. The connectors can
25 be configured to be affixed to at least one frame segment. The frame segments may be unequal in length. In certain aspects, the frame segments are equal in length.

[0010] In certain aspects the retractor frame when assembled is a rounded polygon, e.g., a quadrilateral (square or rectangle). In a further aspect the frame is a rounded quadrilateral. In still a further aspect the frame is a rounded rectangle. The frame can be comprised of two
30 frame segments. A frame segment includes two substantially straight arm portion on each end and a middle portion connecting the substantially straight arm portions forming a U shaped frame segment.

[0011] In certain aspects the outer edge, inner edge, or outer edge and inner edge of the frame segment is toothed and/or grooved along at least a portion of the segment. In a further aspect the top face, bottom face, or top and bottom face comprise a series of grooves or ridges as well.

5 [0012] In certain aspects the top, bottom, or top and bottom faces are substantially planar. In a further aspect the top, bottom, or top and bottom faces are curved (concave or convex) along the short axis of the segment.

[0013] In certain aspects each of the frame segments (substantially straight arms and middle portion) are independently about 2.5, 5, 10, 15, 20, 25, 30, 35, 40, 45, to 50
10 centimeters in length as measured along the non-curved or substantially straight portion, and can include all values and ranges there between. In a further aspect a first substantially straight arm portion of a segment is about 2.5 to 50, 5 to 40, 5 to 30, 5 to 20, 5 to 100, 10 to 40 or 10 to 30 centimeters in length as measured along the non-curved or substantially straight portion and a second substantially straight arm portion is about 2.5 to 50, 5 to 40, 5 to
15 30, 5 to 20, 5 to 100, 10 to 40 or 10 to 30 centimeters in length as measured along the non-curved or substantially straight portion. The arms of a frame segment need not, but may be the same length, where different length arms will be complemented by the other frame segment in the frame. In a further aspect a middle portion of a frame segment is about 2.5 to 50, 5 to 40, 5 to 30, 5 to 20, 5 to 100, 10 to 40 or 10 to 30 centimeters in length as measured
20 along the non-curved or substantially straight portion. In certain aspects the first and second arm portions are of equal length. The length of arm portion is measured from the end of the segment to beginning of the curve portion of the segment (along the non-curved or substantially straight portion). In certain aspects the rounded angle of the frame segment is approximately 90 degrees (+/- 0.5, 1, 2, to 5 degrees). In a further aspect the arm portions of
25 individual frame segments are positioned having the inner edge of first arm portion aligned substantially parallel to the outer end of a second frame segment. In another aspect the top face of a first frame segment can face the bottom face of a second frame segment. The frame segment faces can be in contact with each other or form a gap or space between the frame segments when assembled. In certain embodiments the retractor, in an expanded
30 configuration, has an adjustable internal distance of 2.5, 5, 10, 15, 20, 25, 30, 35, 40, 45, 50, 55, 60, 65, 70, 75, 80, 85, to 90 centimeters, including all ranges and values there between.

[0014] In certain aspects 2, 3, 4, 5, 6 or more retractor blades are coupled to the retractor frame. The retractor blade can have a distal blade portion and a proximal connector or adjustment portion. In a further aspect at least 2 retractor blades are coupled to the frame. In other aspects at least 4 retractor blades are coupled to the frame. In particular aspects 6
5 retractor blades are coupled to the frame. In a further aspect at least one retractor blade is coupled to a retractor blade connector. In certain aspects at least one retractor blade is coupled to a frame segment. In a further aspect at least one retractor blade is configured to be moveable along the retractor frame. In still a further aspect the retractor blade is configured to be moveable up and down with respect to the retractor frame.

10 [0015] Certain embodiments are directed to a surgical retractor frame segment which comprises a first and second substantially straight arm portion connected by a substantially straight middle portion; the frame segment having a curve portion between the arm portions and the middle portion, where the long axis of the middle portion is approximately perpendicular to the long axis of the arm portions, the arm portion projecting to the same side
15 from the middle portion. In certain aspects the arm portions are substantially parallel to each other. Frame segments have a top and bottom face with an inner edge and an outer edge. The frame segment can further comprise one or more expansion stops that can be reversibly connected to the frame segment and form a protrusion on the top or bottom face of the frame segment, the stop can be positioned at or near one or both ends and/or both faces of the frame
20 segment.

[0016] Other embodiments are directed to a surgical retractor connector comprising a body forming two or more lumens, each lumen configured to receive arm portions of separate frame segments. In certain embodiments the surgical retractor connector can include a ratchet mechanism configured to interact with at least one edge (*i.e.*, the inner, outer, or inner
25 and outer edge(s)) of the frame segment when inserted into the surgical retractor connector lumen. The surgical retractor connector can be in (i) an unlocked configuration that allows the arm portions of the frame segments to move with respect to one another allowing the retractor frame to adjust or (ii) a locked configuration that fixes an arm portion of a first frame segment at a position relative to a first arm portion of a second frame segment. The
30 connector can further comprise or be configured to include a retractor blade positioned below the frame and can form a prescribed angle (*e.g.*, perpendicular to) the plane of the frame. The

retractor blade can be fixed to the connector body or removeably connected to the connector body by a retractor blade connector.

[0017] Certain embodiments are directed to methods of using the surgical retractor described herein, the method comprising: inserting retractor blades of a contracted retractor in a wound or incision, expanding the surgical retractor to expose a body cavity, and locking the retractor in position.

[0018] Other embodiments of the invention are discussed throughout this application. Any embodiment discussed with respect to one aspect of the invention applies to other aspects of the invention as well and vice versa. Each embodiment described herein is understood to be embodiments of the invention that are applicable to all aspects of the invention. It is contemplated that any embodiment discussed herein can be implemented with respect to any method or composition of the invention, and vice versa. Furthermore, compositions and kits of the invention can be used to achieve methods of the invention.

[0019] The use of the word "a" or "an" when used in conjunction with the term "comprising" in the claims and/or the specification may mean "one," but it is also consistent with the meaning of "one or more," "at least one," and "one or more than one."

[0020] Throughout this application, the term "about" is used to indicate that a value includes the standard deviation of error for the device or method being employed to determine the value.

[0021] The use of the term "or" in the claims is used to mean "and/or" unless explicitly indicated to refer to alternatives only or the alternatives are mutually exclusive, although the disclosure supports a definition that refers to only alternatives and "and/or."

[0022] As used in this specification and claim(s), the words "comprising" (and any form of comprising, such as "comprise" and "comprises"), "having" (and any form of having, such as "have" and "has"), "including" (and any form of including, such as "includes" and "include") or "containing" (and any form of containing, such as "contains" and "contain") are inclusive or open-ended and do not exclude additional, unrecited elements or method steps.

[0023] Other objects, features and advantages of the present invention will become apparent from the following detailed description. It should be understood, however, that the

detailed description and the specific examples, while indicating specific embodiments of the invention, are given by way of illustration only, since various changes and modifications within the spirit and scope of the invention will become apparent to those skilled in the art from this detailed description.

5

DESCRIPTION OF THE DRAWINGS

[0024] The following drawings form part of the present specification and are included to further demonstrate certain aspects of the present invention. The invention may be better understood by reference to one or more of these drawings in combination with the detailed description of the specification embodiments presented herein.

10

[0025] FIG. 1 is an illustration of an exploded view of one embodiment of an adjustable retractor assembly.

[0026] FIG. 2 is a perspective illustration of one embodiment of an adjustable retractor assembly.

[0027] FIG. 3 is a top view illustration of one embodiment of an adjustable retractor assembly.

15

[0028] FIG. 4 is a bottom-up perspective illustration of one embodiment of an adjustable retractor assembly.

[0029] FIG. 5 is a side view illustration of one embodiment of an adjustable retractor assembly.

20

[0030] FIG. 6 is a perspective illustration of one embodiment of an adjustable retractor assembly in a fully expanded configuration.

[0031] FIG. 7 is a perspective illustration of one embodiment of a retractor blade assembly in isolation.

[0032] FIG. 8 is a perspective illustration of one embodiment of a frame segment in isolation.

25

[0033] FIG. 9 is a focused perspective illustration of one embodiment of a surgical retractor connector in a surgical retractor assembly in a fully expanded configuration.

DESCRIPTION

[0034] Attachment of the surgical retractor described herein to an operating table or other support is not necessary, but can be an option, and therefore use of the surgical retractor described herein does not require involvement of any non-sterile member of the operating team. In addition, the lack of an obtrusive fixed metal frame allows the surgeon increased mobility and positioning at the sides of the patient during the operation. The system remains sterile, and its simple and rapid deployment can be applied to emergency and time sensitive situations.

[0035] The adjustable/expandable system comprising frame segments expanded on connectors or locking ratchet mechanisms allows full exposure of the surgical wound, as the ratchet mechanisms attached to the frame segments allow the wound to be maximally retracted. This design allows the incision to be retracted to its maximal possible dimensions, as it is not limited by the use of a pre-determined ring size (as in the Bookwalter retractor).

[0036] The expandable locking surgical retractor allows the subsequent attachment of multiple retractor blades to provide additional surgical exposure (similar to the Bookwalter retractor). The frame also allows the use of lighting options which attach directly to the frame, improving surgical visualization and illumination of deep wounds and/or spaces.

[0037] The surgical retractor described herein can comprise two frame segments forming a retractor frame by connecting the frame segments with a connector or retractor frame connector (see FIG. 9). In certain aspects the retractor comprises two frame segments joined by two connectors. In certain embodiments a segment will have two substantially straight arm portions joined by a middle portion having a curved portion connecting each substantially straight arm portion, forming a U-shaped frame segment (see FIG. 8). The segments are configured to be assembled to form a rounded polygon, *e.g.*, rounded rectangular, frame. Each segment comprises a top and bottom surface/face with an inner edge facing the inside of the assembled frame and an outer facing outward.

[0038] FIG. 1 shows one embodiment of a surgical retractor frame in an exploded view. In certain embodiments the frame comprises two frame segments 100. Each frame segment

100 has two arm portions 120 and 122 connected by a middle portion 121. Frame segments are connected using connector 103. The frame segments can have teeth or grooves 105 along one or more edges, and/or ridges or grooves (105 or 106) along one or more face. In certain aspects the inner edge of frame segment 100 is configured to interact with connector 103, 5 connector 103 can have ratchet mechanism 104 and portions of the frame segment 100 can have ratchet teeth 105 and/or 106 along an edge and/or a face of the frame segment. The inner edge faces the interior of the opening formed by assembly of frame segments 100. In other aspects frame segments 100 can have notches, grooves, or teeth 105 and/or 106 that can be utilized for securing attachments and the like. In certain aspects notches, grooves, or teeth 10 106 can be positioned in the outer edge of segment 100, the upper face of segment 100, the lower face of segment 100, or combinations thereof. Arm portions (also referred to as substantially straight arm portions herein) 120 and 122 of separate frame segments can be connected by connector 103. In certain embodiments connector 103 comprises a ratchet mechanism 104 that interacts with ratchet teeth 105 to adjustably secure arm portions 120 and 15 122 and allowing expansion and contraction of the assembled frame as well as stabilizing the frame once a desired configuration is achieved. In certain aspects a retractor blade connector 107 can have a fixed or removable retractor blade 108. In certain aspects the frame segment 100 has an expansion stop 109 that protrudes from the face of the frame segment and stops the expansion of the arm portions through the connector. The expansion stop can be a screw, 20 a clip, a pin, or other mechanism that is configured to not allow the frame segment to pass through connector 103.

[0039] With further reference to FIG. 1, the retractor blades 108 can be configured to move up and down with respect to the frame. In this embodiment retractor blade connector 107 can be configured to provide for movement of retractor blade. Retractor blade connector 25 107 can be fixed to the frame using a retractor blade connector locking mechanism 110. The mechanism can include a screw, pin, spring loaded pin or similar adjustable locking mechanisms. Retractor blade connector 107 can be configured to receive the proximal portion (111) of a retractor blade. The proximal portion of the retractor blade can be reversibly locked by using a retractor blade locking mechanism 112. The proximal portion of 30 the retractor can form a retractor blade locking mechanism receiver. The locking mechanism receiver can be a notch, a hole, a cavity or other structure to receive the locking mechanism. When the locking mechanism is engaged the retractor blade is reversibly fixed at that particular position. If one wanted to adjust the retractor blade one would disengage locking

mechanism, move the retractor blade to a new position, and fix that position by engaging locking mechanism with the locking mechanism receiver.

[0040] FIG. 2 shows one embodiment of an assembled retractor frame. Connectors 203 are configured with a release/locking mechanism that allows a person to release frame segment 200 and allow expansion or contraction of the frame as well as providing a locking mechanism to secure the segments in place when desired. In certain aspects connectors 203 comprise a locking, ratchet mechanism 204. In another embodiment the frame segment has a stop mechanism 209 that will stop the expansion of the frame at a selected point. The expansion stop is an elevated portion that cannot pass through the connector resulting the stopping of the frame expansion at the point to the expansion stop. The expansion stop can be a screw or a pin that can be engaged or disengaged as needed. Typically, the expansion stop would be engaged during use to prevent over extension. In certain embodiments not only does the frame have a mechanism for adjustment, but so does the retractor blade portion 208 of the device (212). Retractor blade 208 can have a portion that is proximal to the frame (proximal portion 211) that passes through retractor blade connector 207 and can engage a retractor blade locking mechanism 210 to be reversibly fixed in position. Reversibly fixed means that it will maintain its position until a locking mechanism is disengaged or the engagement is reversed allowing freedom of movement when disengaged. In certain aspects the proximal portion can have one or more locking mechanism receivers that receive the locking mechanism. Also shown in FIG. 2 are notches, grooves, or teeth (ratchet teeth 205 and/or grooves 206) that can be utilized for securing attachments or connectors and the like to the frame.

[0041] FIG. 3 is a top down view of the assembled frame showing frame segment connectors 303 connecting frame segments 300 with example of a frame locking mechanism 309 to secure the segments in place when desired. In certain aspects connectors 303 comprise a locking, ratchet mechanism 304. Also illustrated are frame segment stop mechanism 309. Retractor blade portions 308 are shown with proximal portion 311 of the retractor blade is shown traversing retractor blade connector 307. Retractor blade 308 can be reversibly positioned on the frame using retractor blade locking mechanism 312. The retractor connector locking mechanism 312 is shown interacting with a locking pin 310 that fits in a groove 306. Also shown in FIG. 3 are notches, grooves, or teeth (ratchet teeth 305

and/or grooves 306) that can be utilized for securing attachments or connectors and the like to the frame.

[0042] FIG. 4 is a bottom up perspective view of the assembled frame showing frame segment connectors 403 connecting frame segments 400 with example of a frame locking mechanism 409 to secure the segments in place when desired. In certain aspects connectors 403 comprise a locking, ratchet mechanism 404. Also illustrated are frame segment stop mechanism 409. Retractor blade portions 408 are shown with proximal portion 411 of the retractor blade is shown traversing retractor blade connector 407. Retractor blade 408 can be reversibly positioned on the frame using retractor blade locking mechanism 412. The retractor connector locking mechanism 412 is shown interacting with a locking pin 410 that fits in a groove 406. Also shown in FIG. 4 are notches, grooves, or teeth (ratchet teeth 405 and/or grooves 406) that can be utilized for securing attachments or connectors and the like to the frame.

[0043] FIG. 5 is a side view of the assembled frame showing frame segment connectors 503 connecting frame segments 500 with example of a frame locking mechanism 504 to secure the segments in place when desired. In certain aspects connectors 503 comprise a locking, ratchet mechanism 504. Also illustrated are frame segment stop mechanism 509. Retractor blade portions 508 are shown with proximal portion 511 of the retractor blade is shown traversing retractor blade connector 507. Retractor blade 508 can be reversibly positioned on the frame using retractor blade locking mechanism 512. The retractor connector locking mechanism 512 is shown interacting with a locking pin 510 that fits in a groove 506. Also shown in FIG. 5 are notches, grooves, or teeth (grooves 506) that can be utilized for securing attachments or connectors and the like to the frame.

[0044] FIG. 6 is a top perspective view of the assembled fully extended frame showing frame segment connectors 603 connecting frame segments 600 with example of a frame locking mechanism 604 to secure the segments in place when desired. In certain aspects connectors 603 comprise a locking, ratchet mechanism 604. Also illustrated are frame segment stop mechanism 609. Retractor blade portions 608 are shown with proximal portion 611 of the retractor blade is shown traversing retractor blade connector 607. Retractor blade 608 can be reversibly positioned on the frame using retractor blade locking mechanism 612. The retractor connector locking mechanism 612 is shown interacting with a locking pin 610 that fits in a groove 606. Also shown in FIG. 6 are notches, grooves, or teeth (ratchet notches

605 and grooves 606) that can be utilized for securing attachments or connectors and the like to the frame.

[0045] FIG. 7 shows a retractor blade assembly in isolation. Retractor blade 708 are shown with proximal portion 711 of the retractor blade is shown traversing retractor blade connector 707. Retractor blade 708 can be reversibly positioned on the frame using retractor blade locking mechanism. The retractor connector locking pin 710 fits in a groove or other frame element.

[0046] FIG. 8 shows a frame segment in isolation. A frame segment has a first arm (substantially straight arm) portion 820 and a second arm (substantially straight arm) portion 822 connected by a middle portion 821. Each arm portion 820/822 of a frame segment is configured to interact with a connector in a way that allows assembly and adjustment of the assembled frame of the retractor. The inner edge of the arm portion can be configured to allow connector release/locking (*e.g.*, ratchet 805). In certain aspects the outer edge can be configured to interact with the connector, alone or in combination with the inner edge, *e.g.*, grooves 806. The middle portion 821 is the portion of the frame segment between the arm (substantially straight arm) portions 820. The middle portion 821 having curved portions 823 that connects the arm (substantially straight arm) portions 820/822 to the middle portion 821. In certain aspects, when there are two opposing U-shaped frame segments positioned to be moved apart to open an abdomen, for example, and the retractor configured to lock in place to prevent collapse as it is being expanded and a connector configured with one pawl for release of both frame segments then in this configuration the teeth on the frame segment for interacting with the pawl can be cut or configured in opposite directions to provide locking during expansion using a single pawl. In other aspects an individual pawl can be provided in the appropriate configuration so that the teeth need not be cut or positioned in opposite directions. Teeth on individual frame segments can be cut or configured in the same or counter directions so when the retractor is assembled the teeth are all pointing in opposite directions or in the same direction, respectively.

[0047] FIG. 9 shows one embodiment of frame segment connector (or connector) 903 and frame segment 900 assembly in isolation. Each connector 903 can have one or two receiving openings for receiving the arm portions of two frame segments (900a and 900b). In certain aspects opening can be offset, stacked, or side-by-side. In certain aspects the openings are offset. In other aspects the openings are stacked. In certain aspects a connector 903 has

one opening (*e.g.*, when a connector is a fixed, integral part of one end of a frame segment); or it can have two or more openings. In certain embodiments one frame segment is attached to two connectors, for example, the connector can be fixed to one or both ends of a frame segment. In other aspects one connector can be adjustably connected to two frame segments, for example the connector has one or two openings for receiving an arm portion of a first frame segment and an arm portion of a second frame segment. The frame segments can be attached, coupled, or connected through a shared connector. Connector 903 can comprise a ratchet(s) or pawl(s) 904, which are configured to ratchet in opposite directions. Ratchet(s) or pawl(s) 904 can be configured to interact with a toothed surface of two adjacent segments (e.g., 905a and 905b). The ratchet(s) or pawl(s) can be configured to allow the frame to be expanded by applying a force away from the centerpoint of the retractor without disengaging the ratchet. In other aspects the ratchet is configured to not allow contraction of the frame unless the ratchet is disengaged. Other release/locking mechanisms can be integrated into the current design, so the ratchet mechanism is just one example. The connector can include 1, 2, 3, or more ratchets or pawls configured to engage one or more frame segment. In certain aspects, the connector comprises individual ratchets or pawls configured to interact separately and/or independently with individual frame segments.

[0048] The position of the connector along a segment can be fixed by engaging a lock mechanism that can engage the teeth or grooves of a frame segment(s) for locking purposes. In other embodiments the connector can be integrated into one end of the frame segment, in this case the connector may only have one opening and one ratchet mechanism since the connector is fixed at one end of the segment.

[0049] A retractor blade need not be associated with the connector. A retractor blade or other implement can be fixed to one or more retractor blade connector or can be an accessory implement that attaches to the frame at positions other than the connector points. A plurality of retractor blades or other implements can be attached to the frame, in certain aspects 2, 3, 4, 5, 6, 7, 8, 9, 10 or more retractor blades and/or other implements can be attached to the frame. The only limiting factor for attachment is the space available along the frame and physical interference between attachments.

[0050] A frame segment comprises various regions or portions. A frame segment has a first arm (substantially straight arm) portion and a second arm (substantially straight arm) portion connected by a middle portion. Each arm portion of a frame segment is configured to

interact with a connector in a way that allows assembly and adjustment of the assembled frame of the retractor. The inner edge of the arm portion can be configured to allow connector release/locking. In certain aspects the outer edge can be configured to interact with the connector, alone or in combination with the inner edge. The middle portion is the portion of the frame segment between the arm portions. The middle portion has a curved portion that connects the arm portions to the middle portion. The curve portion forms an angle between the arm portions and the middle portion. The curve portion can be characterized by the angle formed between the long axis of an arm portion and middle portion. In certain aspects this angle is between 85 and 95 degrees. In certain aspects the segment angle is or is about 90 degrees.

[0051] The frame segment, connector, and retractor blade can be metallic, metallic alloy, plastic, or combination thereof. In certain aspects the retractor is made of material that can be autoclaved or otherwise sterilized (*e.g.*, irradiated, etc.). The frame segment can be a formed rod (having a bend or angle) with circular, oval, square, or rectangular cross section. The connectors are configured to receive and reversibly engage the frame segments of the frame. The segments are coupled connectors to form a retractor frame. Each connector couples two segments.

CLAIMS

1. An adjustable surgical retractor comprising:
 - a retractor frame having an adjustable circumference comprising a first and second frame segment and two connectors, the first and second frame segment comprising:
 - a first and second substantially straight arm portion and a middle portion connecting the first and second substantially straight arm portions, the first and second substantially straight arm portion and the middle portion substantially in the same plane, where the long axis of the first and second substantially straight arm portions are parallel to each other and project to the same side of the middle portion, the middle portion forms a first and a second bend so that the long axis of the middle portion is perpendicular to the long axes of the first and second substantially straight arm portions, each frame segment having a top and bottom face with an inner edge and an outer edge, wherein the frame segments are configured to connect with a first arm portion of the first frame segment with the first arm portion of the second frame segment and the second arm portion of the first frame segment with the second arm portion of the second frame segment forming an adjustable retractor frame, and
 - the connectors configured to receive the first and second substantially straight arm portions of the first and second frame segments to form the retractor frame, wherein the connector can be in (i) an unlocked configuration that allows the substantially straight arm portions of the frame segments to move with respect to one another allowing the retractor frame to adjust or (ii) a locked configuration that fixes a substantially straight arm portion at a position relative to a substantially straight arm portion of the other frame segment; and
 - two or more retractor blades coupled to the frame where the face of the retractor blade forms an angle with the plane of the frame.
2. The retractor of claim 1, wherein the frame segments further comprise an expansion stop on one or both faces and at one or both ends of the frame segment that is configured to

stop expansion of the frame prior to a frame segment passing completely through a connector.

3. The retractor of claim 1, wherein the connector further comprise a removable stop coupled with a prescribed slot or pattern of holes formed in the frame segment that together are configured to reversibly lock the connector in place.
4. The retractor of claim 1, wherein the connectors are configured to allow one or more frame segments to be expanded and do not allow one or more frame segments to be contracted.
5. The retractor of claim 4, wherein the connectors are affixed or removeably affixed to at least one frame segment.
6. The retractor of claim 5, wherein the frame segments are unequal in length.
7. The retractor of claim 5, wherein the frame segments are equal in length.
8. The retractor of claim 1, wherein the frame segments are equal in length.
9. The retractor of claim 4, wherein the connector comprises a pawl configured to engage one or more frame segment.
10. The retractor of claim 9, wherein the connector comprises individual pawls configured to interact with individual frame segments.
11. The retractor of claim 1, wherein the connector is configured to position the ends of the frame segments in a stacked configuration.
12. The retractor of claim 1, wherein the connector is configured to position the ends of the frame segments in an offset configuration.
13. The retractor of claim 1, wherein the connector is further comprised of a motorized, controlled, screw drive, worm gear, or removable locking system that allows the movement of both adjacent frame segments towards or away from each other allowing the frame to be contracted or expanded when using the system.
14. The retractor of claim 1, wherein the connector further comprises one or more spring loaded brake mechanisms.

15. The retractor of claim 1, wherein the retractor blades are adjustable and the connector is configured to receive a proximal portion of the retractor blade and to reversibly fix the retractor blade position with a locking mechanism incorporated into the connector, wherein the proximal portion of the retractor blade is moveable up and down until locked by a retractor blade locking mechanism.
16. The retractor of claim 1, wherein the frame is a rounded polygon.
17. The retractor of claim 1, wherein the frame is a rounded quadrilateral.
18. The retractor of claim 1, wherein the outer edge of the frame segment forms one or more notches or teeth.
19. The retractor of claim 18, wherein the teeth of the first frame segment are directed in an opposite direction relative to the teeth on the second frame segment.
20. The retractor of claim 1, wherein the substantially straight arm portions of adjacent frame segments are positioned having the inner edge of one substantially straight arm portion aligned substantially parallel to the outer edge of an adjacent frame segment.
21. The retractor of claim 1, wherein the substantially straight arm portions of the frame segment are about 2.5 to 50 centimeters in length and the middle portion of the frame segment is 2.5 to 100 centimeters in length.
22. The retractor of claim 1, wherein the retractor in an expanded configuration has an adjustable internal distance of 2.5 to 90 centimeters.
23. The retractor of claim 1, wherein rounded angle of the frame segment is approximately 90 degrees.
24. The retractor of claim 1, wherein 2, 3, 4, 5, or 6 retractor blades are coupled to the retractor frame.
25. The retractor of claim 1, wherein 2, 3, 4, 5, or 6 retractor blades are comprised so they may become decoupled from the retractor frame.
26. The retractor of claim 1, wherein at least one retractor blade is coupled to a connector.

27. The retractor of claim 1, wherein at least one retractor blade coupled to a frame segment.
28. The retractor of claim 1, wherein at least one retractor blade is configured to be moveable along the retractor frame.
29. The retractor of claim 1, wherein the retractor is coupled to a bed frame.
30. The retractor of claim 1, wherein the retractor is attached to patient after being expanded.
31. The retractor of claim 1, wherein the retractor is configured for human surgical retraction.
32. The retractor of claim 1, wherein the retractor is configured for veterinary surgical retraction.
33. A surgical retractor frame segment comprising a first and second substantially straight and substantially parallel, with respect to each other, arm portions connected by a substantially straight middle portion, the middle portion being connected to each substantially straight arm portion by a curve portion, the frame segment having a top and bottom face with an inner edge and an outer edge.
34. The frame segment of claim 33, further comprising one or more expansion stops that can be reversibly connected to the top or bottom face of the frame segment at or near one or both ends of the frame segment.
35. A surgical retractor connector comprising a body forming two or more lumens, each lumen configured to receive substantially straight arm portions of two adjacent frame segments, a ratchet mechanism configured to interact with at least one edge of a frame segment when inserted into the connector lumen, wherein the connector can be in (i) an unlocked configuration that allows the substantially straight arm portions of the adjacent frame segments to move with respect to one another allowing the circumference of the frame to adjust or (ii) a locked configuration that fixes a substantially straight arm portion at a position relative to a substantially straight arm portion of the adjacent frame segment.

36. The connector of claim 35, further comprising a retractor blade positioned below the frame and forms an angle with the plane of the frame.
37. The connector of claim 36, wherein the retractor blade is affixed to the connector body.
38. The connector of claim 36, wherein the retractor blade is attached a retractor blade arm that is configured to be removeably connected to the connector body.
39. A method of using the surgical retractor of claim 1, comprising:
inserting a contracted retractor of claim 1 in a wound or incision; and
expanding the surgical retractor in one or more superior, inferior, or lateral direction
to expose a body cavity; and
locking the frame.

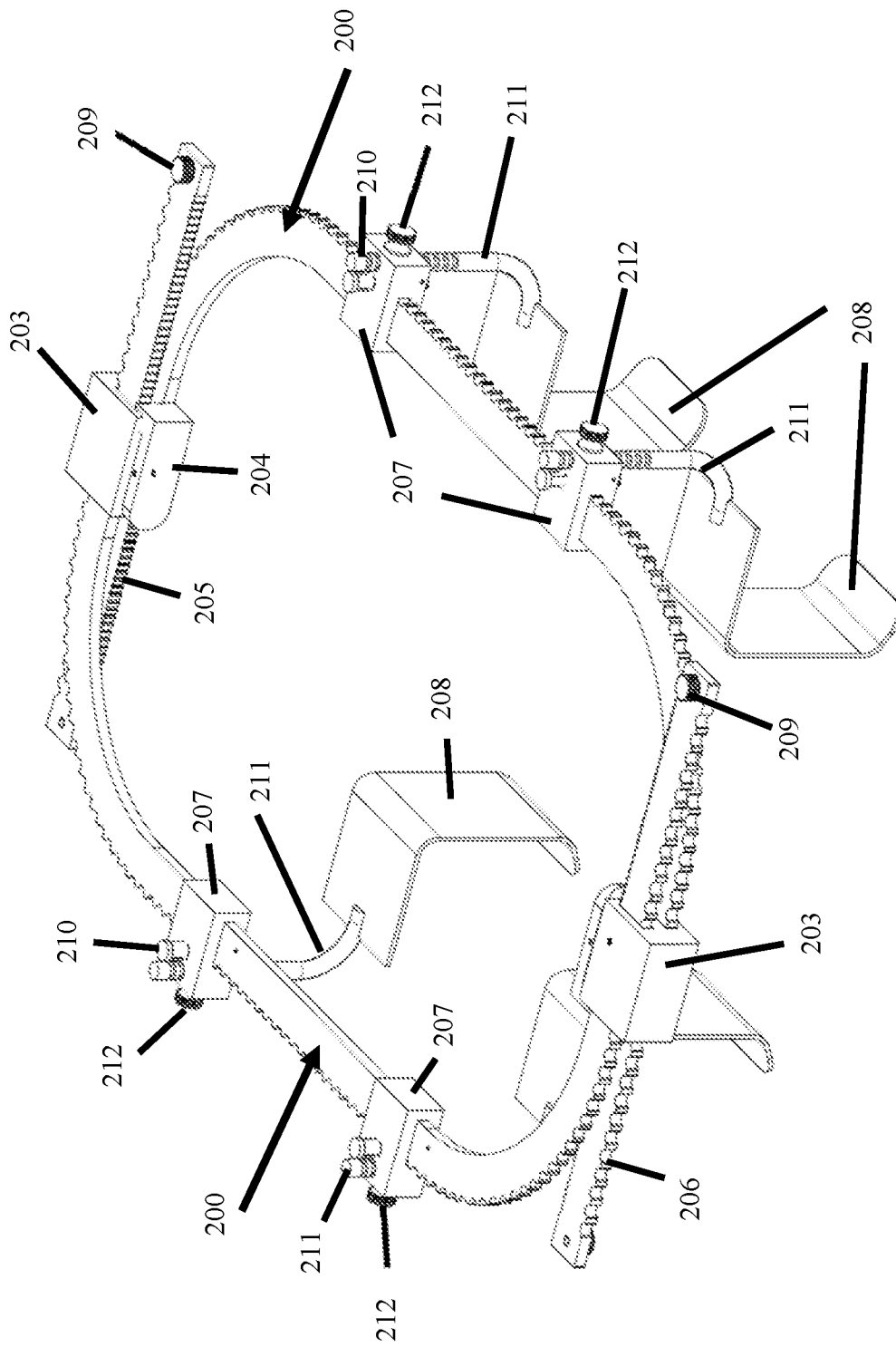

FIG. 2

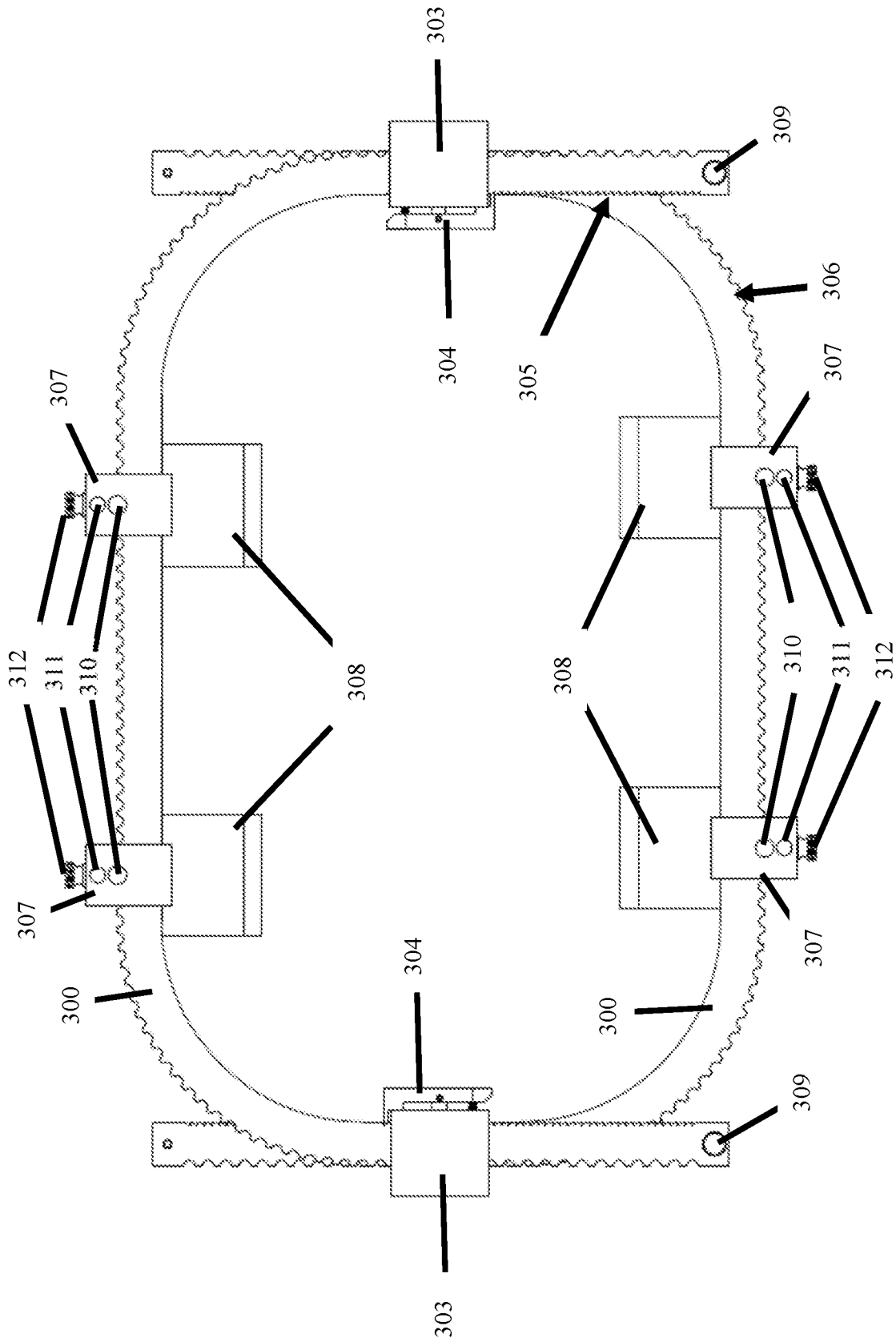

FIG. 3

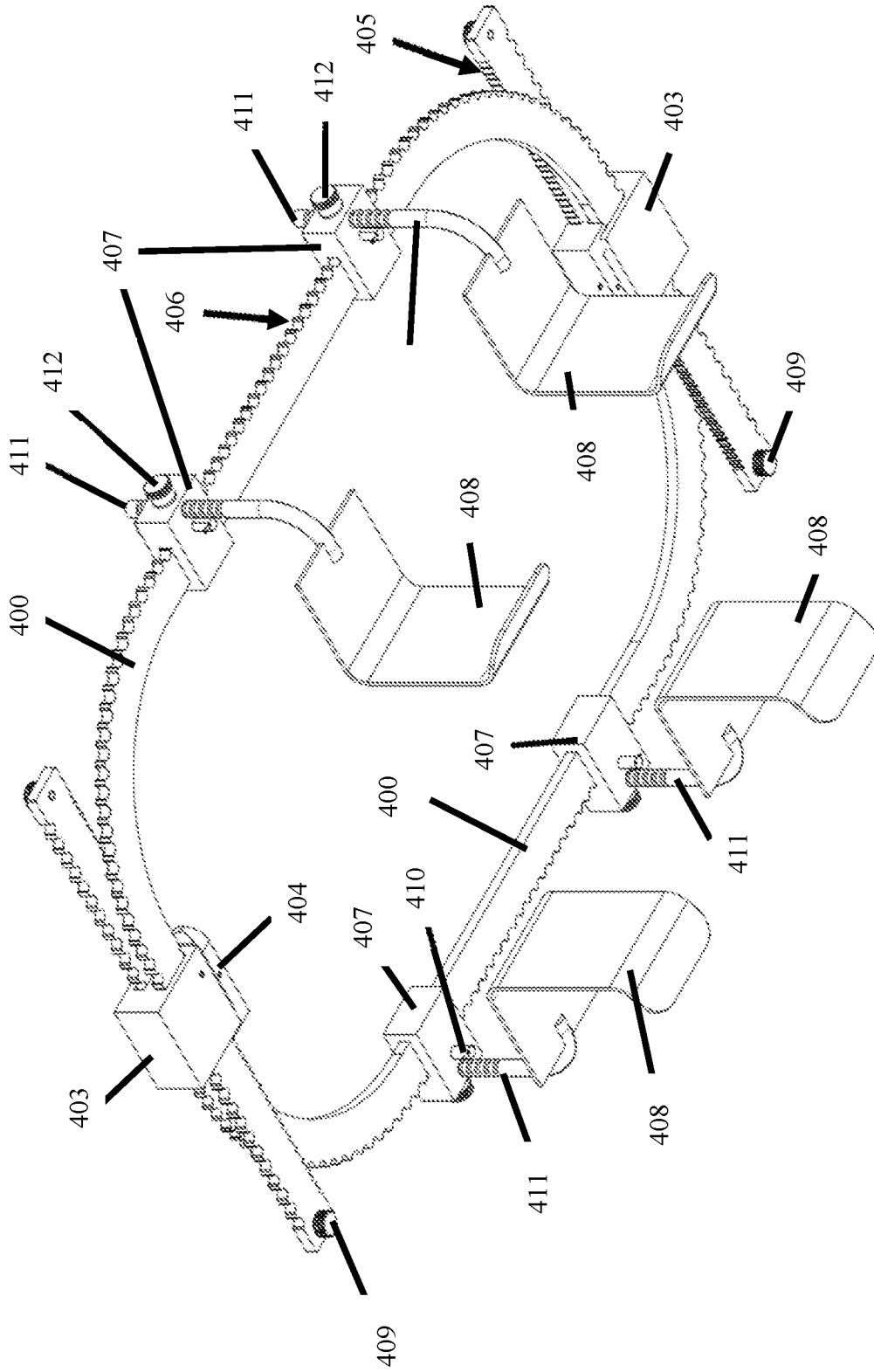

FIG. 4

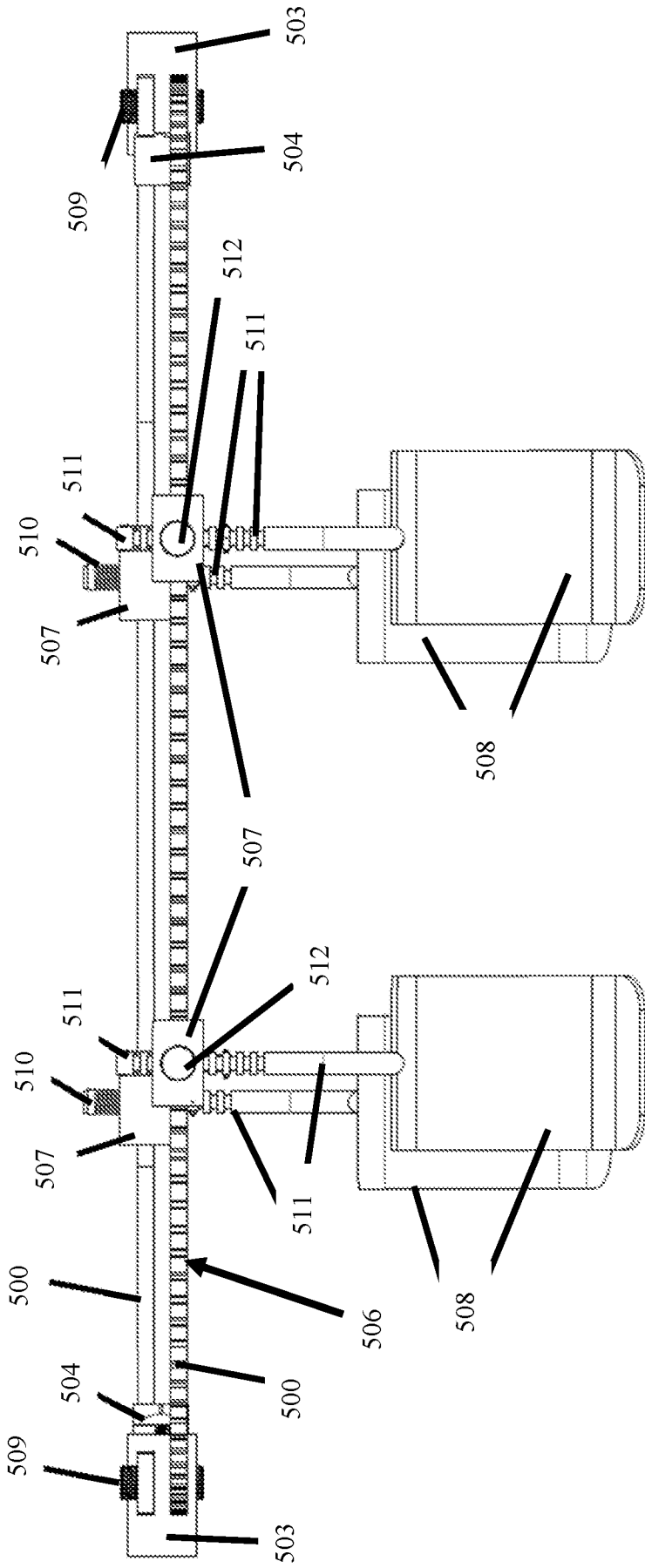

FIG. 5

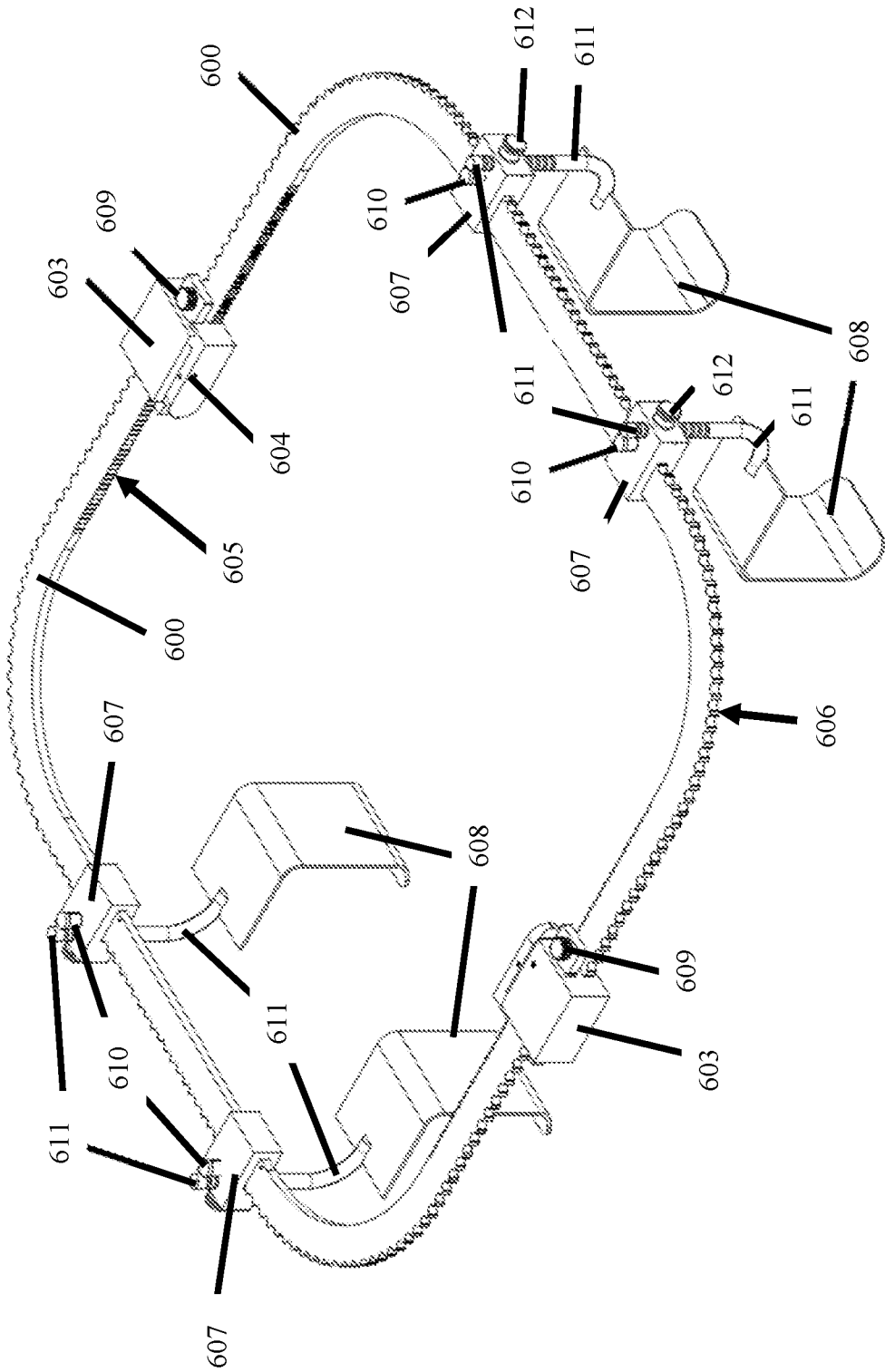

FIG. 6

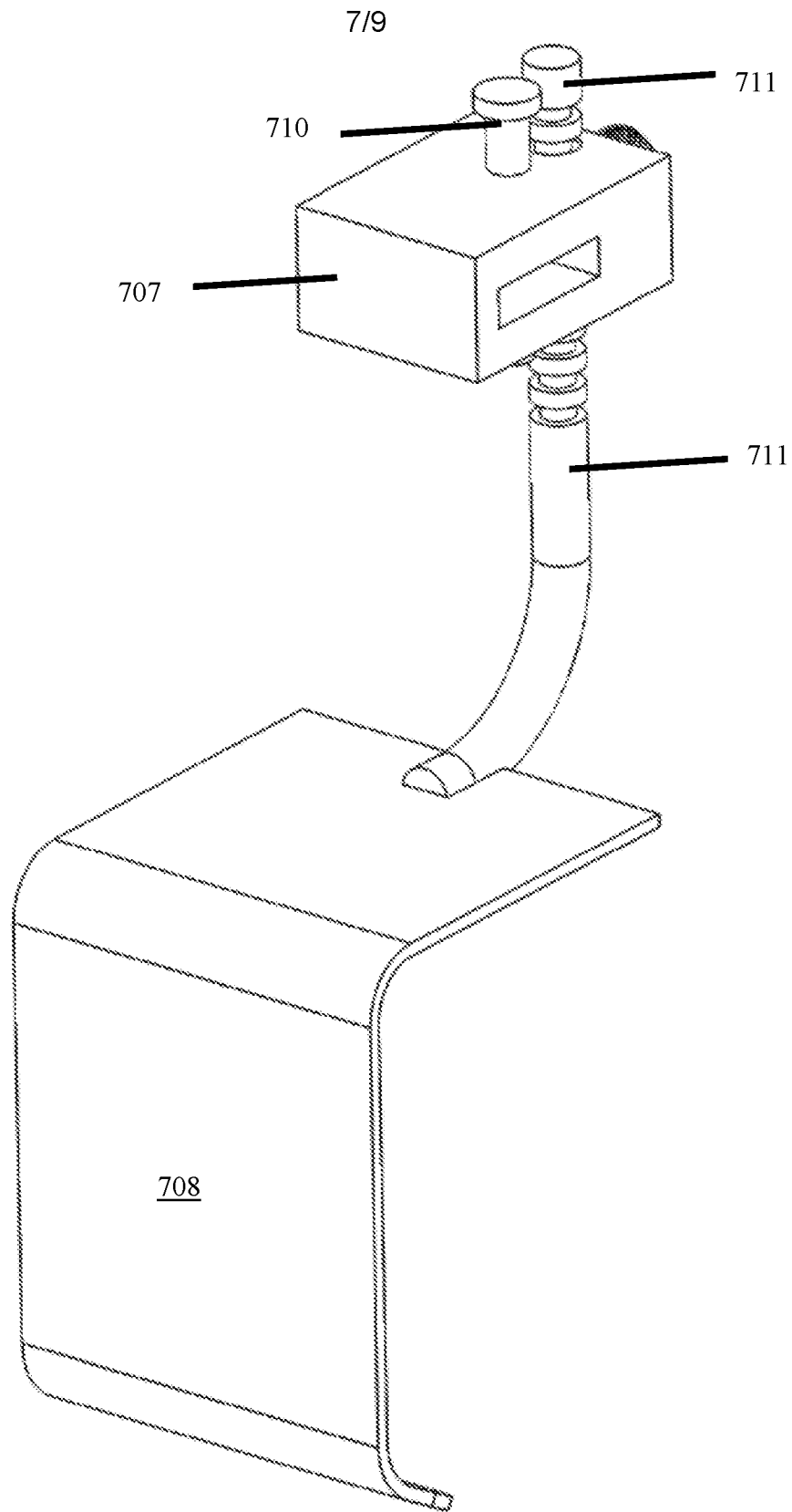

FIG. 7

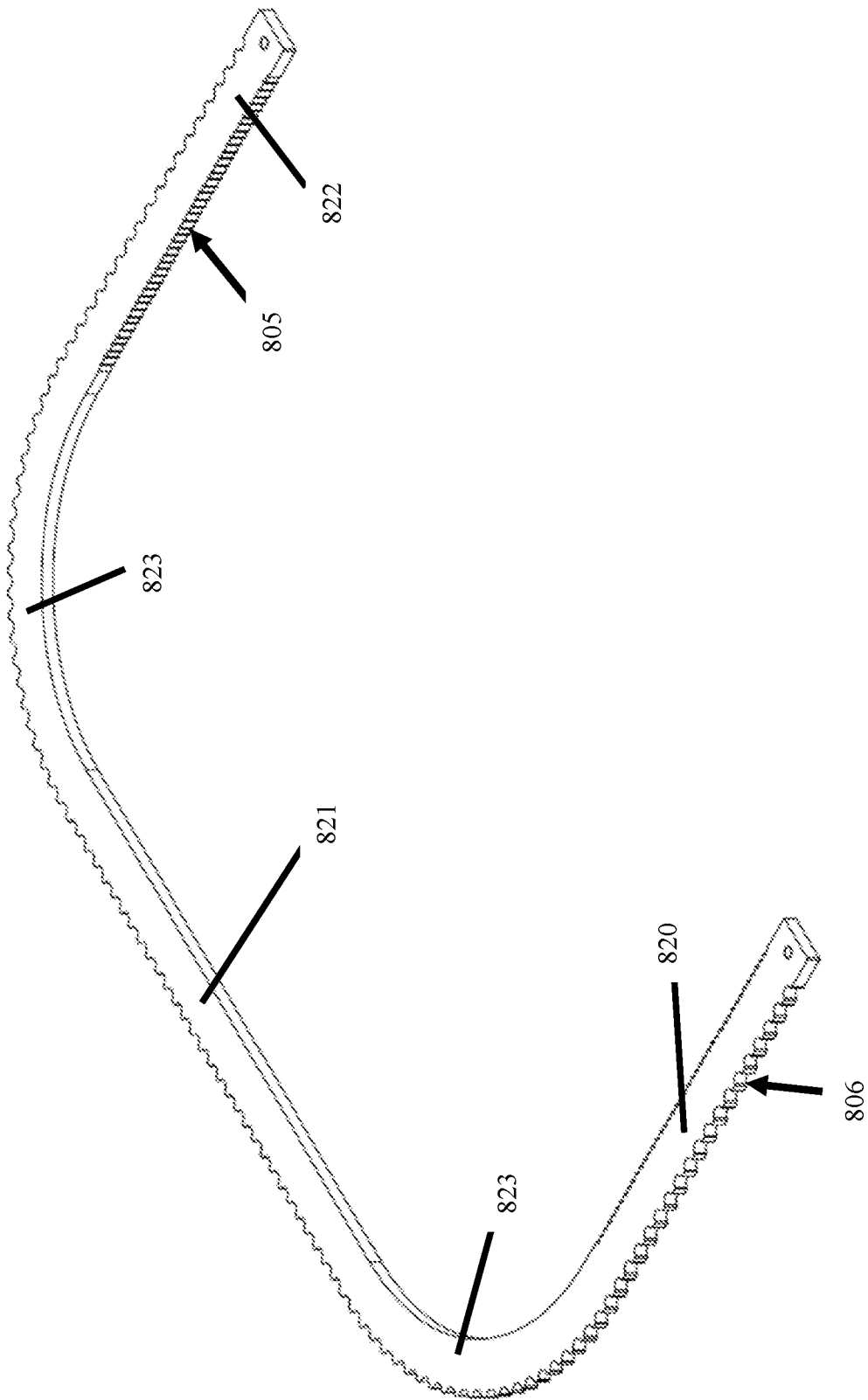

FIG. 8

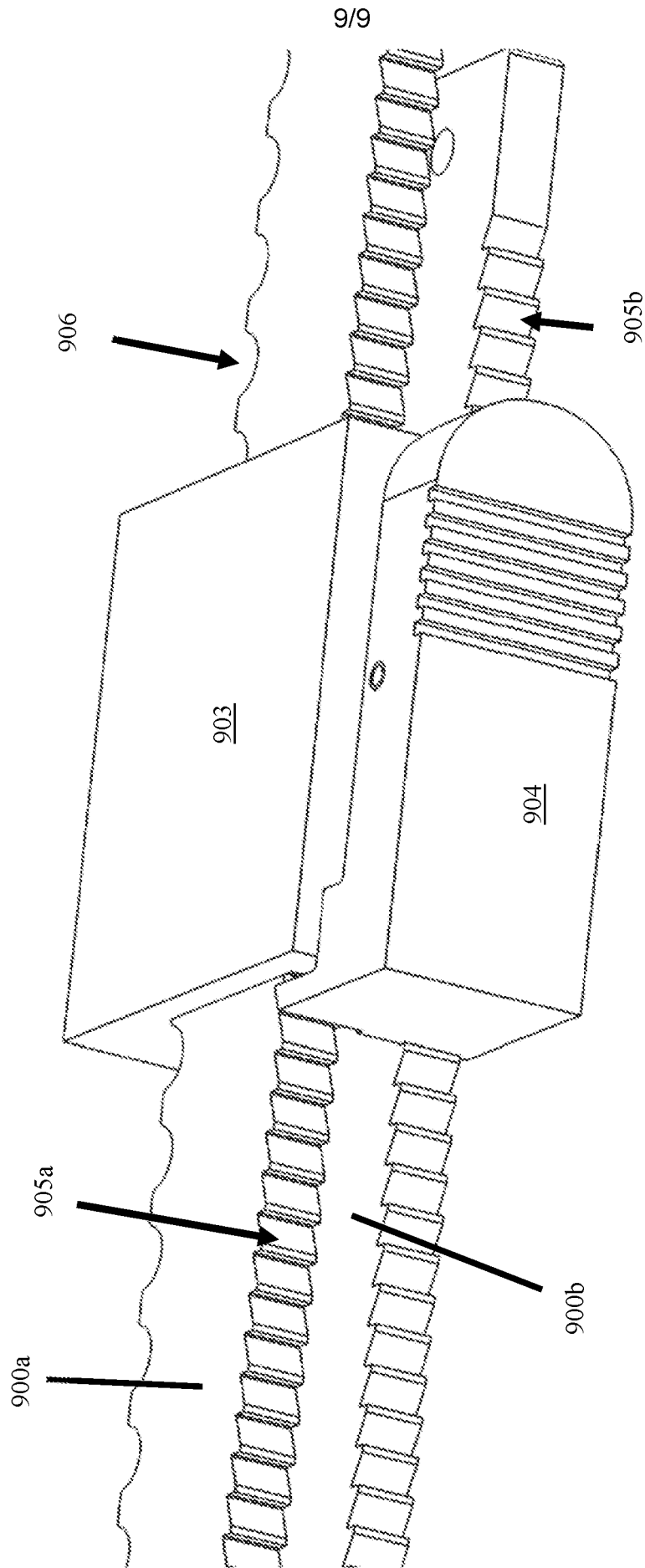

FIG. 9

INTERNATIONAL SEARCH REPORT

International application No.

PCT/US2019/051549

A. CLASSIFICATION OF SUBJECT MATTER

IPC(8) - A61B 17/02; A61B 1/32; H02M 1/32; H02M 1/44 (2019.01)

CPC - A61B 17/02; A61B 17/0206; A61B 17/0293; A61B 90/50; H02M 1/32; H02M 1/44 (2019.08)

According to International Patent Classification (IPC) or to both national classification and IPC

B. FIELDS SEARCHED

Minimum documentation searched (classification system followed by classification symbols)

See Search History document

Documentation searched other than minimum documentation to the extent that such documents are included in the fields searched

USPC - 600/233; 600/214 (keyword delimited)

Electronic data base consulted during the international search (name of data base and, where practicable, search terms used)

See Search History document

C. DOCUMENTS CONSIDERED TO BE RELEVANT

Category*	Citation of document, with indication, where appropriate, of the relevant passages	Relevant to claim No.
X --- Y	JP 2018-523558 A (Chesutero Ramon Efu et al) 23 August 2018 (23.08.2018) see original and machine translation	1-13, 15-39 ----- 14
Y	US 6,808,493 B1 (BOOKWALTER et al) 26 October 2004 (26.10.2004) entire document	14
A	US 9,216,016 B2 (FIECHTER et al) 22 December 2015 (22.12.2015) entire document	1-39
A	CN 203001015 U (HUBEI MEDICAL COLLEGE SUBSIDIARY TAIHE HOSPITAL) 19 June 2013 (19.06.2013) see original and machine translation	1-39

 Further documents are listed in the continuation of Box C. See patent family annex.

* Special categories of cited documents:

"A" document defining the general state of the art which is not considered to be of particular relevance

"E" earlier application or patent but published on or after the international filing date

"L" document which may throw doubts on priority claim(s) or which is cited to establish the publication date of another citation or other special reason (as specified)

"O" document referring to an oral disclosure, use, exhibition or other means

"P" document published prior to the international filing date but later than the priority date claimed

"T" later document published after the international filing date or priority date and not in conflict with the application but cited to understand the principle or theory underlying the invention

"X" document of particular relevance; the claimed invention cannot be considered novel or cannot be considered to involve an inventive step when the document is taken alone

"Y" document of particular relevance; the claimed invention cannot be considered to involve an inventive step when the document is combined with one or more other such documents, such combination being obvious to a person skilled in the art

"&" document member of the same patent family

Date of the actual completion of the international search

29 October 2019

Date of mailing of the international search report

15 NOV 2019

Name and mailing address of the ISA/US

Mail Stop PCT, Attn: ISA/US, Commissioner for Patents

P.O. Box 1450, Alexandria, VA 22313-1450

Facsimile No. 571-273-8300

Authorized officer

Blaine R. Copenheaver

PCT Helpdesk: 571-272-4300

PCT OSP: 571-272-7774