

(No Model.)

2 Sheets—Sheet 1.

H. H. KELLEY.

GOVERNOR AND REVERSING GEAR FOR ENGINES.

No. 523,210.

Patented July 17, 1894.

Fig. 1

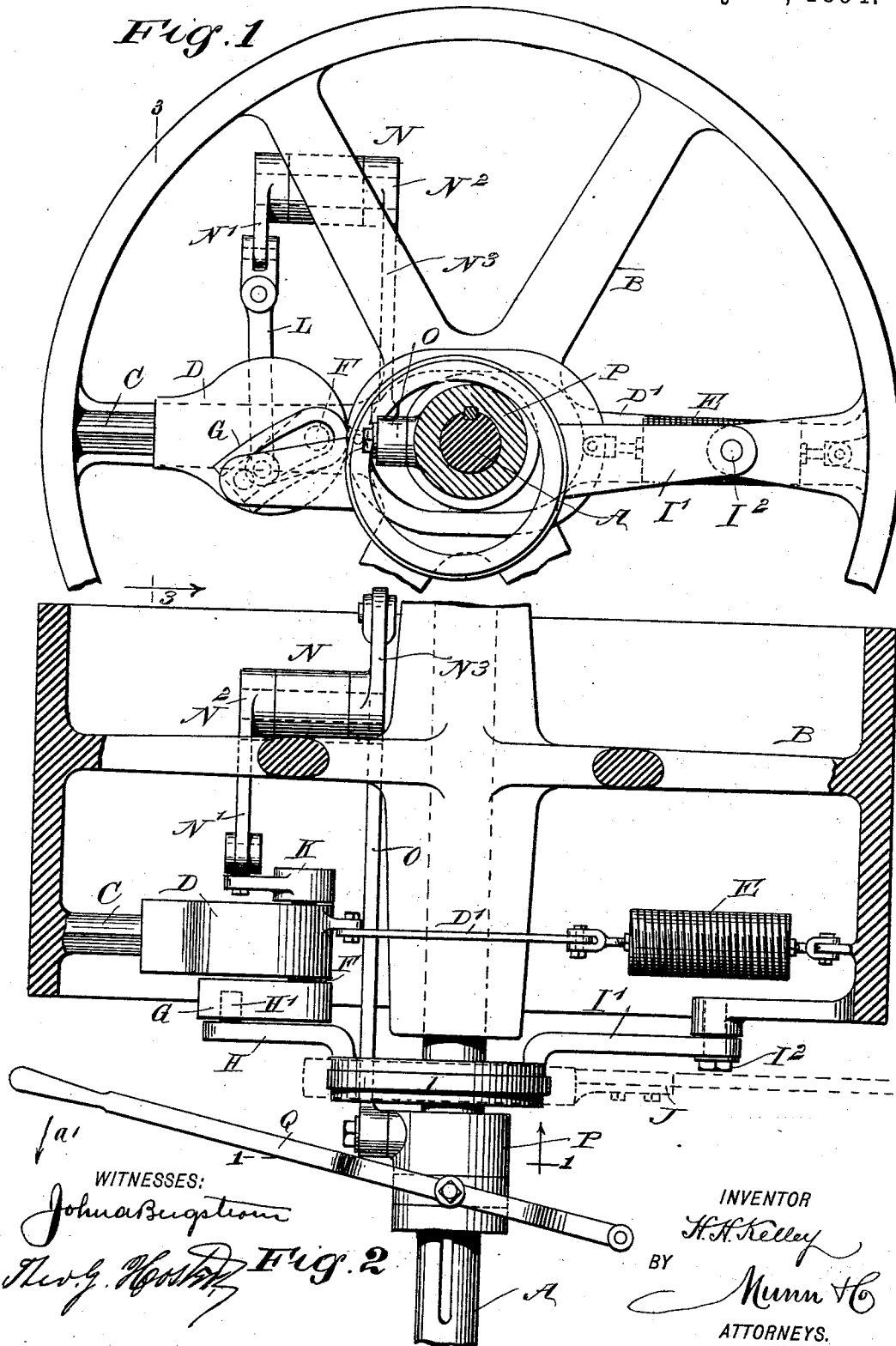

WITNESSES:

John A. Supton

Thos. G. Howard

Fig. 2

INVENTOR

H. H. Kelley

BY

Munn & Co

ATTORNEYS.

(No Model.)

2 Sheets—Sheet 2.

H. H. KELLEY.

GOVERNOR AND REVERSING GEAR FOR ENGINES.

No. 523,210.

Patented July 17, 1894.

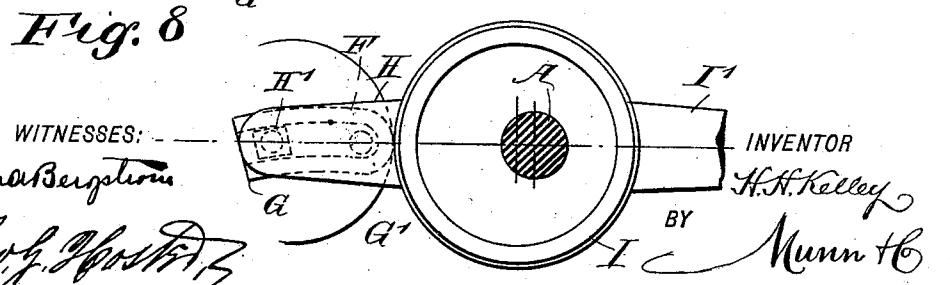
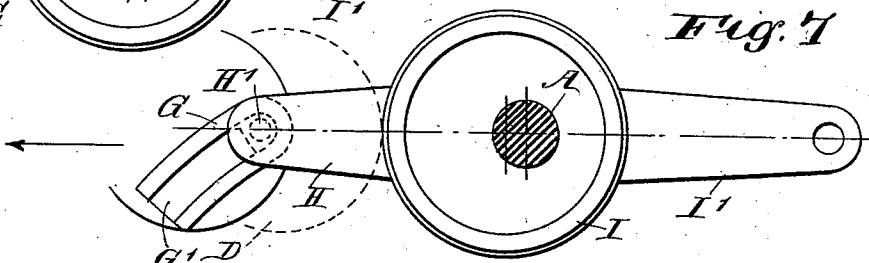
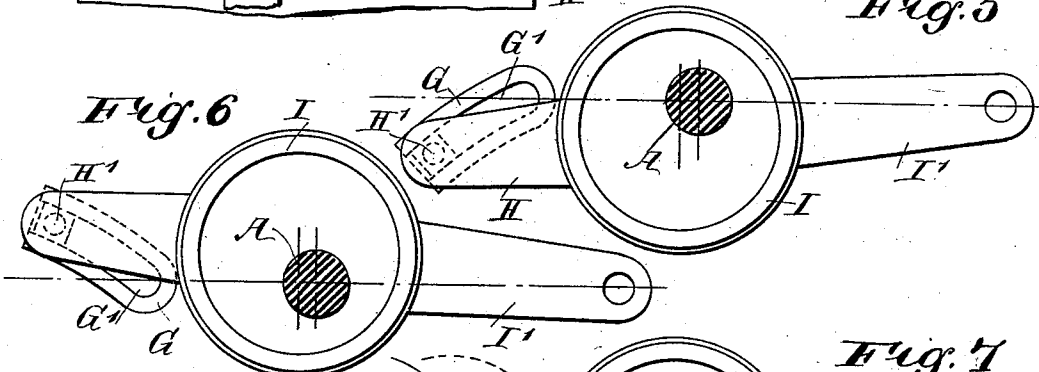
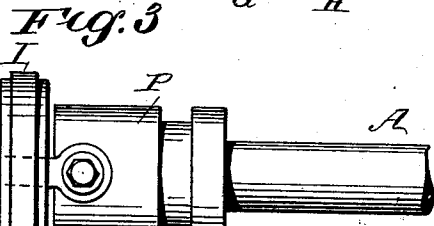
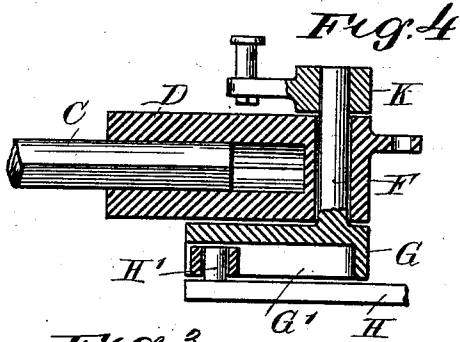
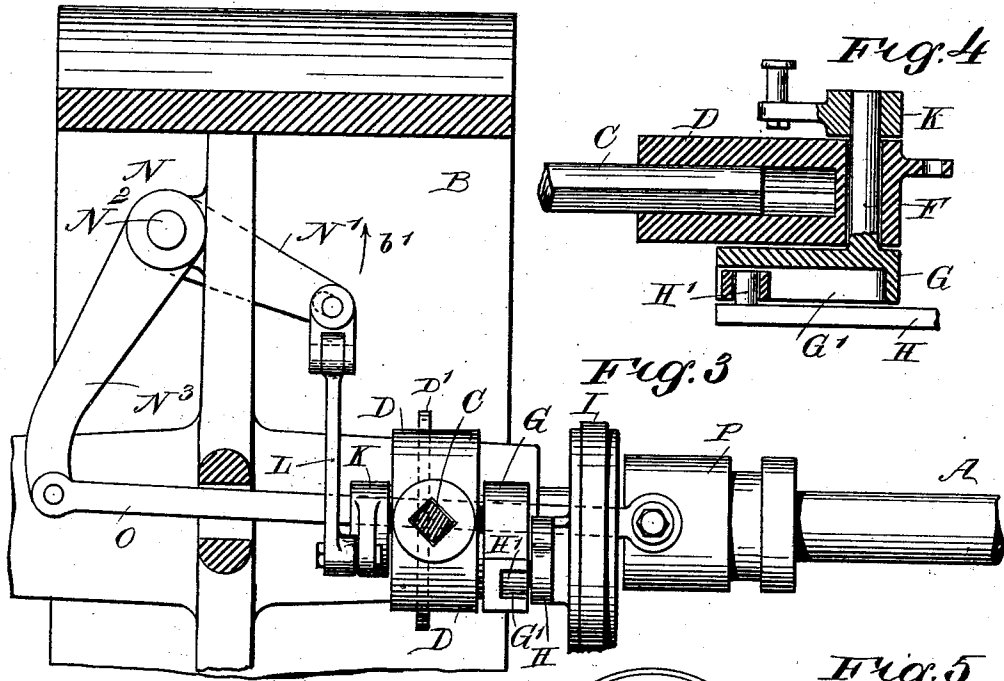

WITNESSES:
John Bergstrom
Thos. G. Spotted

INVENTOR
H. H. Kelley
 BY
Munn & Co
 ATTORNEYS.

UNITED STATES PATENT OFFICE.

HARRY H. KELLEY, OF ELYRIA, OHIO.

GOVERNOR AND REVERSING-GEAR FOR ENGINES.

SPECIFICATION forming part of Letters Patent No. 523,210, dated July 17, 1894.

Application filed April 4, 1894. Serial No. 506,330. (No model.)

To all whom it may concern:

Be it known that I, HARRY H. KELLEY, of Elyria, in the county of Lorain and State of Ohio, have invented a new and Improved Governor and Reversing-Gear for Steam-Engines, of which the following is a full, clear, and exact description.

The object of the invention is to provide a new and improved combined governor and reversing gear for steam engines, which is simple and durable in construction, and arranged in such a manner that both the governor and the reversing lever fully control a single eccentric, at the same time permitting each to independently shift the eccentric.

The invention consists of a pivoted eccentric carried around at its pivot by the driving shaft and connected in the usual manner with the engine valve, the said eccentric being controlled in its swinging motion from a slidable weight, having its guideways in a support attached to the main driving shaft.

The invention also consists of certain parts and details, and combinations of the same, as will be hereinafter described and then pointed out in the claims.

Reference is to be had to the accompanying drawings, forming a part of this specification, in which similar letters of reference indicate corresponding parts in all the figures.

Figure 1 a sectional face view of the improvement on the line 1—1 of Fig. 2. Fig. 2 is a sectional plan view of the same. Fig. 3 is a transverse section of the same on the line 3—3 of Fig. 1. Fig. 4 is an enlarged sectional side elevation of the slidable weight and adjacent parts; and Figs. 5, 6, 7 and 8, are face views of the eccentric and connected parts, showing the various positions of the eccentric relative to the shaft.

On the main driving shaft A of the engine is secured a wheel B formed with a radially extending guideway C on which is fitted to slide a weight D connected at its inner end by a link D' with a spring E attached to the inner surface of the rim of the wheel B directly opposite the guideway C. The link D' is provided with an elongated slot through which extends loosely the hub of the wheel B, so as not to interfere with the centrifugal action of the weight D on the guideway C, it

being understood that the said weight is always pulled back to its normal innermost position on a decrease of speed of the engine, by the spring E.

In the weight D and near the inner end thereof is journaled a transversely-extending shaft F on the front end of which is secured a link G formed with a curved slot G' engaged by a friction roller H' held on the free end of an arm H extending from and forming an integral part of the inner face of the eccentric I made in the form of a ring, through the opening of which passes eccentrically and loosely the main driving shaft A.

The eccentric I is rigidly held on an arm I' pivoted at I² to a bracket projecting from the rim of the wheel B, the arms I' and H extending in opposite directions from the said eccentric I, as plainly shown in the drawings. The eccentric I is connected by the usual straps J and rod with the valve of the engine, so that the movement of the eccentric with the shaft A and carried around by the wheel B, actuates the valve of the engine to regulate the admission of steam to the steam cylinder.

Now, it will be seen that when on an increase of speed the weight D slides outwardly on the guideway C, then the link G is shifted and consequently the friction roller H' of the arm H, whereby the eccentric I is moved relative to the main driving shaft A, so as to cause the valve to cut off sooner, to admit less steam to the cylinder of the engine, until the speed of the latter is reduced to a normal speed.

In order to shift the link G independently of the movement of the slidable weight D, from a reversing lever, I provide the following device: The rear end of the shaft F carries a crank arm K; see Figs. 2, 3 and 4, pivotally-connected by a link L with the arm N' of a bell crank lever N fulcrumed at N² on one of the spokes of the wheel B. The other arm N³ of the said bell crank lever N is pivotally-connected by a link O with a sleeve P mounted to slide on and to turn with the main driving shaft A, the said sleeve being engaged by a shifting or reversing lever Q under the control of the operator to move the said sleeve P on the shaft A.

Now, it will be seen that when the several parts are in the position as shown in Figs. 2 and 3, for instance, and the operator moves the lever Q in the direction of the arrow a' , then the sleeve P is caused to slide on the shaft A, whereby the link O exerts a pull on the bell crank lever N to swing the latter in the direction of the arrow b' ; see Fig. 3. The upward movement of the arm N' of the bell crank lever N exerts a pull on the link L and crank arm K to turn the shaft F so that the link G secured on the said shaft, swings in a similar direction, whereby the arm H is caused to swing and consequently the eccentric I is shifted across the main driving shaft A until the eccentric center is on the opposite side of the center of the shaft A, as will be readily understood by reference to Figs. 5 and 6, so that the movement of the eccentric is reversed and consequently that of the valve controlling the inlet of the steam to the cylinder.

Now, by the arrangement described, the governor and the reversing lever fully control the single eccentric I, and at the same time the governor and the reversing lever can independently shift the eccentric so as to control the valve in the engine. As the engine slackens its speed due to the decrease in the admission of steam to the cylinder and as the result of an earlier cut off, centrifugal force acting upon the weight D is diminished and the spring E pulls the said weight inward toward the hub of the wheel B. This latter movement of the weight wedges the eccentric down again, which increases the travel of the valve and consequently increases the admission of steam, the alternate increasing and diminishing of the admission of steam to the cylinder keeping the speed of the engine uniform at all times. When the engine is reversed, then the operation is exactly the same with the exception that the eccentric I is moved across the shaft in a downward direction, instead of an upward direction.

The device shown and described is applicable to portable and hoisting engines, but is more especially designed as an automatic shaft governor for marine engines.

Having thus fully described my invention, I claim as new and desire to secure by Letters Patent—

1. A device of the class described, comprising a wheel secured on the driving shaft of the engine, a guideway held on the said wheel and arranged radially, a weight fitted to slide on the said guideway and drawn on by a spring to hold the weight normally in an innermost position, a ring-shaped eccentric pivoted on the said wheel and having a radial arm, and a device interposed between said

weight and eccentric, and loosely connecting them, substantially as shown and described.

2. A device of the class described, comprising a wheel secured on the driving shaft of the engine, a guideway held on the said wheel and arranged radially, a weight fitted to slide on the said guideway and drawn on by a spring to hold the weight normally in an innermost position, a ring-shaped eccentric pivoted on the said wheel and connected with the said weight, and a shaft mounted to turn in the said weight and carrying a link engaged at its groove by a friction roller on an arm on the said pivoted eccentric, substantially as shown and described.

3. A device of the class described, comprising a wheel secured on the driving shaft of the engine, a guideway held on the said wheel and arranged radially, a weight fitted to slide on the said guideway and drawn on by a spring to hold the weight normally in an innermost position, a ring-shaped eccentric pivoted on the said wheel and connected with the said weight, a shaft mounted to turn in the said weight, and a carrying link engaged at its groove by a friction roller on an arm on the said pivoted eccentric, a crank arm held on the said shaft, a link pivotally-connected with the said crank arm, a bell crank lever fulcrumed on the said wheel and connecting with the said link, a second link pivotally-connected with the said bell crank lever, and a collar mounted to turn with and fitted to slide on the main driving shaft, substantially as shown and described.

4. A device of the class described, comprising a wheel secured on the driving shaft of the engine, a guideway held on the said wheel and arranged radially, a weight fitted to slide on the said guideway and drawn on by a spring to hold the weight normally in an innermost position, a ring-shaped eccentric pivoted on the said wheel and connected with the said weight, a shaft mounted to turn in the said weight, and carrying a link engaged at its groove by a friction roller on an arm on the said pivoted eccentric, a crank arm held on the said shaft, a link pivotally-connected with the said crank arm, a bell crank lever fulcrumed on the said wheel and connected with the said link, a second link pivotally-connected with the said bell crank lever, a collar mounted to turn with and fitted to slide on the main driving shaft, and a shifting lever connected with the said collar and under the control of the operator, substantially as shown and described.

HARRY H. KELLEY.

Witnesses:

JAMES H. LEONARD,
CHAS. A. METCALF.