



(43) International Publication Date
23 July 2015 (23.07.2015)

(51) International Patent Classification:

B01D 53/94 (2006.01) *F01N 3/20* (2006.01)
B01J 35/00 (2006.01) *F01N 3/28* (2006.01)

(21) International Application Number:

PCT/CA2014/000032

(22) International Filing Date:

17 January 2014 (17.01.2014)

(25) Filing Language:

English

(26) Publication Language:

English

(71) Applicant: **VIDA HOLDINGS CORP. LTD.** [CA/CA];
68 Clover Leaf Street, Woodbridge, Ontario L4L 5H3
(CA).

(72) Inventors: **PLATI, Stefano**; 28 Orleans Circle, Wood-
bridge, Ontario L4H 0V3 (CA). **KOYANAGI, Gregory**
Kiyoshi; 5 Boot Terrace, North York, Ontario M3J 0A1
(CA). **BLAGOJEVIC, Voislav**; 340 Assiniboine Road,
Apt. 1311, North York, Ontario M3J 1L2 (CA).

(74) Agents: **RIDOUT & MAYBEE LLP** et al.; 2000 Argentinia
Road, Plaza 1, Suite 301, Mississauga, Ontario L5N 1P7
(CA).

(81) Designated States (unless otherwise indicated, for every
kind of national protection available): AE, AG, AL, AM,
AO, AT, AU, AZ, BA, BB, BG, BH, BN, BR, BW, BY,
BZ, CA, CH, CL, CN, CO, CR, CU, CZ, DE, DK, DM,
DO, DZ, EC, EE, EG, ES, FI, GB, GD, GE, GH, GM, GT,
HN, HR, HU, ID, IL, IN, IR, IS, JP, KE, KG, KN, KP, KR,
KZ, LA, LC, LK, LR, LS, LT, LU, LY, MA, MD, ME,
MG, MK, MN, MW, MX, MY, MZ, NA, NG, NI, NO, NZ,
OM, PA, PE, PG, PH, PL, PT, QA, RO, RS, RU, RW, SA,
SC, SD, SE, SG, SK, SL, SM, ST, SV, SY, TH, TJ, TM,
TN, TR, TT, TZ, UA, UG, US, UZ, VC, VN, ZA, ZM,
ZW.

(84) Designated States (unless otherwise indicated, for every
kind of regional protection available): ARIPO (BW, GH,
GM, KE, LR, LS, MW, MZ, NA, RW, SD, SL, SZ, TZ,
UG, ZM, ZW), Eurasian (AM, AZ, BY, KG, KZ, RU, TJ,
TM), European (AL, AT, BE, BG, CH, CY, CZ, DE, DK,
EE, ES, FI, FR, GB, GR, HR, HU, IE, IS, IT, LT, LU, LV,
MC, MK, MT, NL, NO, PL, PT, RO, RS, SE, SI, SK, SM,
TR), OAPI (BF, BJ, CF, CG, CI, CM, GA, GN, GQ, GW,
KM, ML, MR, NE, SN, TD, TG).

Published:

— with international search report (Art. 21(3))

(54) Title: METHOD FOR SIZING AND POSITIONING CATALYTIC CONVERTER INSULATION

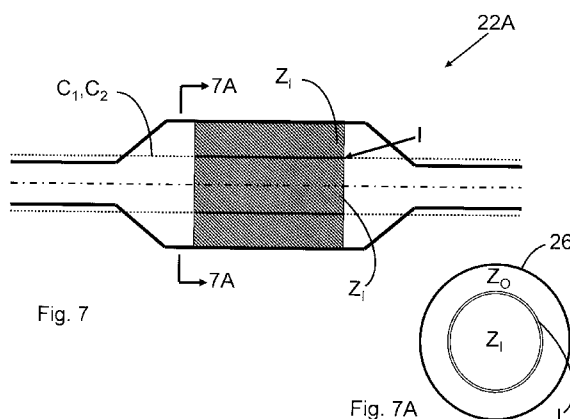

(57) Abstract: The substrate is used in a catalytic converter can to which a cylindrical inlet pipe leads and has an inner catalytic zone portion, an outer catalytic zone portion and an insulation material thermally separating the portions. The insulation extends through the substrate and has a uniform cross-section substantially defined by the intersection of two notional cylinders and the up-stream face of the substrate, each notional cylinder having: a nominal diameter that is between 1.08 and 1.20 of the diameter of the inlet pipe; a thickness of 1-4 mm; and an axis aligned with the gas direction at the point of maximum velocity at the intersection of the inlet pipe and the can. One of the cylinders is associated with the gas flow at the lower limit of the operating range and the other of the cylinders is associated with the gas flow at the upper limit of the operating range.

WO 2015/106332 A1

METHOD FOR SIZING AND POSITIONING CATALYTIC CONVERTER INSULATION

FIELD OF THE INVENTION

The invention relates to the field of exhaust gas treatment.

BACKGROUND OF THE INVENTION

It is known to reduce backpressure by the interposition of a layer of insulation in the substrate of a catalytic converter; using the teachings of PCT/CA2013/000663, incorporated herein by reference, for any given application, suitable insulation can be designed through routine experimentation by persons of ordinary skill in the art.

SUMMARY OF THE INVENTION

Forming one aspect of the invention is a method for expediting the design of an insulation layer in a catalytic converter substrate for a combustion engine that has a operating power range having upper and lower limits, the substrate being of the type which, in use, substantially fully occupies, but for the diffuser cones, a catalytic converter can to which a cylindrical inlet pipe leads. The method comprises the steps:

- i. determining the gas direction at the point of maximum gas velocity at the intersection of the inlet pipe and the can, when the engine is operating at the lower limit of the operating power range;
- ii. determining the gas direction at the point of maximum gas velocity at the intersection of the inlet pipe and the can, when the engine is operating at the upper limit of the operating power range; and
- iii. defining a benchmark catalytic converter substrate.

In the benchmark:

- an outer catalytic zone portion of the substrate surrounds an inner catalytic zone portion of the substrate;
- an insulation material thermally separates the inner and outer zones;
- an insulation material extends through the substrate and has a uniform cross-section throughout the length of the substrate;
- the uniform cross-section is substantially defined by the intersection of two notional cylinders and the upstream face of the substrate;
- each notional cylinder has: a nominal inner diameter that is between 1.08 and 1.20 of the diameter of the inlet pipe; a thickness of 0.8 -4 mm; and an axis aligned with the gas direction at the point of maximum velocity at the intersection of the inlet pipe and the can
- one of the notional cylinders is associated with the gas flow at the lower limit of the operating power range and the other of the notional cylinders is associated with the gas flow at the upper limit of the operating power range .

Forming another aspect of the invention is an improved catalytic converter substrate, the substrate being of the type used with a combustion engine that has a operating power range having upper and lower limits; and further being of the type used in a catalytic converter can to which a cylindrical inlet pipe leads.

The improvement comprises: an inner catalytic zone portion of the substrate; an outer catalytic zone portion of the substrate, surrounding the inner catalytic zone; and an insulation material thermally separating the zones.

The insulation material extends through the substrate and has a uniform cross-section throughout the length of the substrate. The uniform cross-section is substantially defined by the intersection of two notional cylinders and the upstream face of the substrate, each notional cylinder having: a nominal inner diameter that is between 1.08 and 1.20 of the diameter of the inlet pipe; a thickness of 0.8 - 4 mm; and an axis aligned with the gas direction at the point of maximum velocity at the intersection of the inlet pipe and the can. One of the notional cylinders is associated with the gas flow at the lower limit of the operating power range and the other of the notional cylinders is associated with the gas flow at the upper limit of the operating power range.

Advantages, features and characteristics of the present invention will become apparent to persons of ordinary skill in the art upon review of the following detailed description and the appended drawings, the latter being briefly described hereinafter.

BRIEF DESCRIPTION OF THE DRAWINGS

- FIG. 1 shows a schematic axially symmetric catalytic converter
- FIG. 2 shows a schematic catalytic converter with angled inlet
- FIG. 3 shows a schematic catalytic converter with curved inlet
- FIG. 4 is a view similar to FIG. 1 showing the points of maximum gas velocity at the intersection of the inlet pipe and the can at the lower limit of an operating power range and the upper limit of an operating power range

FIG. 5 is a view similar to FIG. 2 showing the points of maximum gas velocity at the intersection of the inlet pipe and the can at the lower limit of the operating power range and the upper limit of the operating power range;

FIG. 6 is a view similar to FIG. 3 showing the points of maximum gas velocity at the intersection of the inlet pipe and the can at the lower limit of the operating power range and the upper limit of the operating power range;

FIG. 7 shows a schematic catalytic converter similar to FIG. 1;

FIG. 7A is a view along section 7A-7A of FIG. 1;

FIG. 8 shows a schematic catalytic converter similar to FIG. 1;

FIG. 8A is a view along section 8A-8A of FIG. 7;

FIG. 9 shows a schematic catalytic converter similar to FIG. 1;

FIG. 9A is a view along section 9A-9A of FIG. 9;

FIG. 10 shows a schematic catalytic converter similar to FIG. 3;

FIG. 10A is a view along section 10A-10A of FIG. 10;

FIGS. 11A-D show inlet back pressure as a function of insulation position for a variety of catalytic converters of the type shown in FIG. 7.

DETAILED DESCRIPTION OF AN EXEMPLARY METHOD

Reference is now made to FIGS. 1-3 which show exemplary catalytic converter systems with which the invention can be usefully deployed:

- FIG. 1 shows a schematic axially symmetric catalytic converter system 22A
- FIG. 2 shows a schematic catalytic converter system 22B with angled inlet
- FIG. 3 shows a schematic catalytic converter system 22C with curved inlet

Each system 22A, 22B and 22C includes a can 24 having a cylindrical housing 26 and a pair of diffuser cones 28 and a honeycomb ceramic substrate 30 substantially fully occupying the can 24. The can 24 in system 22A is fed by a cylindrical inlet pipe 32A aligned with the axis of the can 24; in system 22B, the inlet pipe 32B is cylindrical but disposed at angle α to the axis of the can; and in system 22C, the inlet pipe 32C is curved.

Initial steps in the method involve, in respect of any given engine with which the converter is to be used, the determination of the gas direction at the point of maximum gas velocity

- when the engine is at the lower limit of the operating power range of concern;
and
- when the engine is at the upper limit of the operating power range of concern.

The operating range varies from application to application and in some cases, the range may be defined by a single value. For example, stationary engines, such as generators, are often used at a single power setting, typically 60 – 80% of designed power, while large freight trucks are operated at a highway cruising power level (20 – 30% of maximum) for most of their operating time. In the case of common passenger vehicles, the operating range used may be that defined by the typical operating power range, i.e. something between 30 and 80 percent of the maximum power of the engine. The determination of gas direction can be done through measurement, but will normally be done through Computational Fluid Dynamics (CFD) modelling, as the interposition of measurement devices can themselves create flow disruption

In the context of the catalytic converter shown in FIG. 3, there exists a substantial difference between the points of maximum gas velocity $V_{\max 1}$, $V_{\max 2}$: at lower gas velocities the centrifugal force that the gas molecules are exposed to in the curved pipe is lower and the maximum of the exhaust gas distribution $V_{\max 1}$ is closer to the center of the pipe; at higher gas velocities the centrifugal force is stronger and the maximum of the exhaust gas distribution $V_{\max 2}$ is closer to the pipe wall, all as shown in FIG. 6.

CFD simulations show, that, for a curved inlet pipe 58 mm in diameter, the difference between the low and high flow positions is 11 mm.

Similar simulations can be done for the catalytic converters of FIGS. 2 and 3, as in some exceptional circumstances, some divergence may occur, but nominally, the point of maximum gas velocity, and both high and low flow conditions, is simply aligned with the centreline of the inlet pipe in both cases, as shown in FIGS. 4 and 5., wherein $V_{\max 1}$ and $V_{\max 1}$ are defined by the same vector.

With this information in hand, a benchmark is designed. In the benchmark:

- an outer tubular outer catalytic zone portion of the substrate surrounds an inner catalytic zone portion of the substrate;
- an insulation material thermally separates the inner catalytic zone and the outer outer catalytic zone;
- an insulation material extends through the substrate and has a uniform cross-section throughout the length of the substrate;
- the uniform cross-section is substantially defined by the intersection of two notional cylinders and the upstream face of the substrate;
- each notional cylinder has: a nominal inner diameter that is between 1.08 and 1.20 of the diameter of the inlet pipe; a thickness of 0.8-4 mm; and an axis aligned with the gas direction at the point of maximum velocity at the intersection of the inlet pipe and the can; and
- one C_1 of the notional cylinders is associated with the gas flow at the lower limit of the operating power range and the other C_2 of the notional cylinders is associated with the gas flow at the upper limit of the operating power range

The benchmarks for the exemplary systems of FIGS. 4-6 are shown in FIGS. 7-9; in each benchmark, the outer zone is indicated by Z_o , the inner zone is indicated by Z_i and the insulation layer is indicated by I .

It will be evident that, in the converter of FIG. 1, the notional cylinders C_1 and C_2 will be coincident and define a cylinder of insulation, as indicated in FIG. 7A; in the converter of FIG. 2, the notional cylinders C_1 and C_2 will be coincident and will define an ellipse, as indicated in FIG. 8A; and in the converter of FIG. 6, the notional cylinders will be overlapping but not coincident and the insulation is defined by an ovaloid $C_1 C_2$ that overlaps both projections, as indicated in FIG. 9A.

A variation to FIG. 9 is shown in FIG. 10, wherein the inlet pipe is curved and enters adjacent the sidewall of the housing. The location causes a portion of the ovaloid C_1+C_2 defined by notional cylinders C_1 and C_2 to project outside the cylindrical housing 26, such that only an arc lies within the housing 26. To accommodate this notional loss of flow area, the endpoints of the arc are drawn apart from one another, as indicated by arrows A in FIG. 10, until such time as the area encompassed between the arc and the can sidewall is equivalent to the area of the original ovaloid. The same adjustment applies for converters of the type shown in FIG. 8, if the projection lies outside the can.

Without intending to be bound by theory, it is believed that the benchmark will expedite the design of insulated catalytic converter substrates, as this reduce the routine experimentation otherwise required of persons of ordinary skill in the art.

Experimentation has been carried out which supports this conclusion. By way of example, FIGS. 11A-11D show inlet back pressure as a function of insulation position for a variety of catalytic converters of the type shown in FIG. 7. FIG. 11A shows results for a 26mm radius inlet pipe. FIG. 11B shows results for a 29 mm radius inlet pipe. FIG. 11C shows results for a 32 mm radius inlet pipe. FIG. 11D shows results a 35 mm radius inlet pipe. All other simulation parameters were equal, including exhaust gas temperature and flow rate through the catalytic converter.

Optimum insulation position was defined as that producing the minimum area averaged back pressure in the inlet pipe approx. 30 cm from the catalytic converter can. In each case, the optimum insulation diameter fell within the range of 1.08 and 1.20 of the inlet pipe diameter.

Whereas but a specific embodiment of a method is described, and various specific embodiments of catalytic converter substrates are described, it will be evident that variations are possible.

For example, whereas the examples contemplate usefulness with cylindrical inlet pipes, the methodology would be useful for pipes that departed slightly from the perfectly cylindrical; thus, "cylindrical" in the description and in the claims should be understood as any pipe that appears generally cylindrical in cross section.

Additionally, whereas the terms "inner" and "outer" are used in the specification and claims, it should be understood that in the variation contemplated by FIG. 10, the "outer" zone is that portion indicated as lying above insulation I and the "inner" zone is that portion indicated as lying below insulation I; "inner" and "outer" are references to proximity to the inlet pipe axis.

Accordingly, the invention should be understood as limited only by the accompanying claims, purposively construed.

CLAIMS

- 1 A method for use with: a combustion engine that has an operating power range having upper and lower limits and a substrate which, in use, substantially fully occupies, but for the diffuser cones, a catalytic converter can to which a cylindrical inlet pipe leads from the engine, the method comprising the steps of:

determining the gas direction at the point of maximum gas velocity at the intersection of the inlet pipe and the can, when the engine is operating at the lower limit of the operating range;

determining the gas direction at the point of maximum gas velocity at the intersection of the inlet pipe and the can, when the engine is operating at the upper limit of the operating range; and

defining a benchmark catalytic converter substrate, wherein, in the benchmark: an outer catalytic zone portion of the substrate surrounds an inner catalytic zone portion of the substrate; an insulation material thermally separates the zones; the insulation material extends through the substrate and has a uniform cross-section throughout the length of the substrate; the uniform cross-section is substantially defined by the intersection of two notional cylinders and the upstream face of the substrate;

wherein each notional cylinder has: a nominal diameter that is between 1.08 and 1.20 of the diameter of the inlet pipe; a thickness of 1-4 mm; and an axis aligned with the gas direction at the point of maximum velocity at the intersection of the inlet pipe and the can; and

one of the notional cylinders is associated with the gas flow at the lower limit of the operating power range and the other of the notional cylinders is associated with the gas flow at the upper limit of the operating power range.

2. An improved catalytic converter substrate, the substrate being of the type used with a combustion engine that has an operating range having upper and lower limits ; and further being of the type used in a catalytic converter can to which a cylindrical inlet pipe leads, wherein the improvement comprises:

an inner catalytic zone portion of the substrate;

an outer catalytic zone portion of the substrate, surrounding the inner catalytic zone;

an insulation material thermally separating the inner and outer zones,

wherein

the insulation material extends through the substrate and has a uniform cross-section throughout the length of the substrate;

the uniform cross-section is substantially defined by the intersection of two notional cylinders and the upstream face of the substrate, each notional cylinder having: a nominal diameter that is between 1.08 and 1.20 of the diameter of the inlet pipe; a thickness of 1-4 mm; and an axis aligned with the gas direction at the point of maximum velocity at the intersection of the inlet pipe and the can; and

one of the cylinders is associated with the gas flow at the lower limit of the operating range and the other of the cylinders is associated with the gas flow at the upper limit of the operating range.

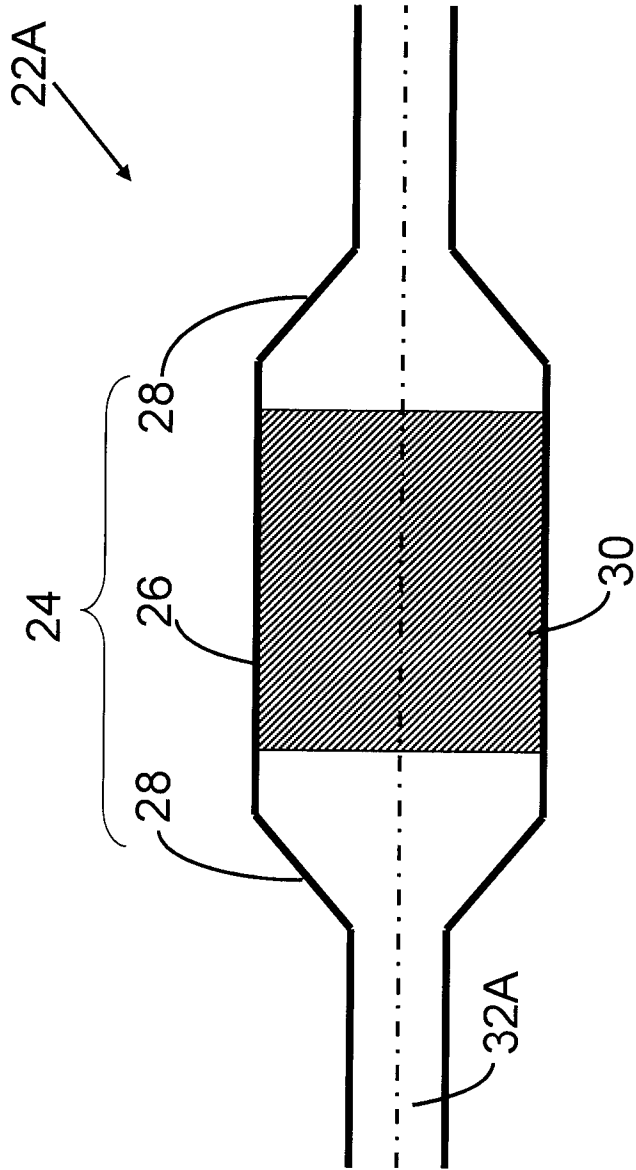

Fig. 1

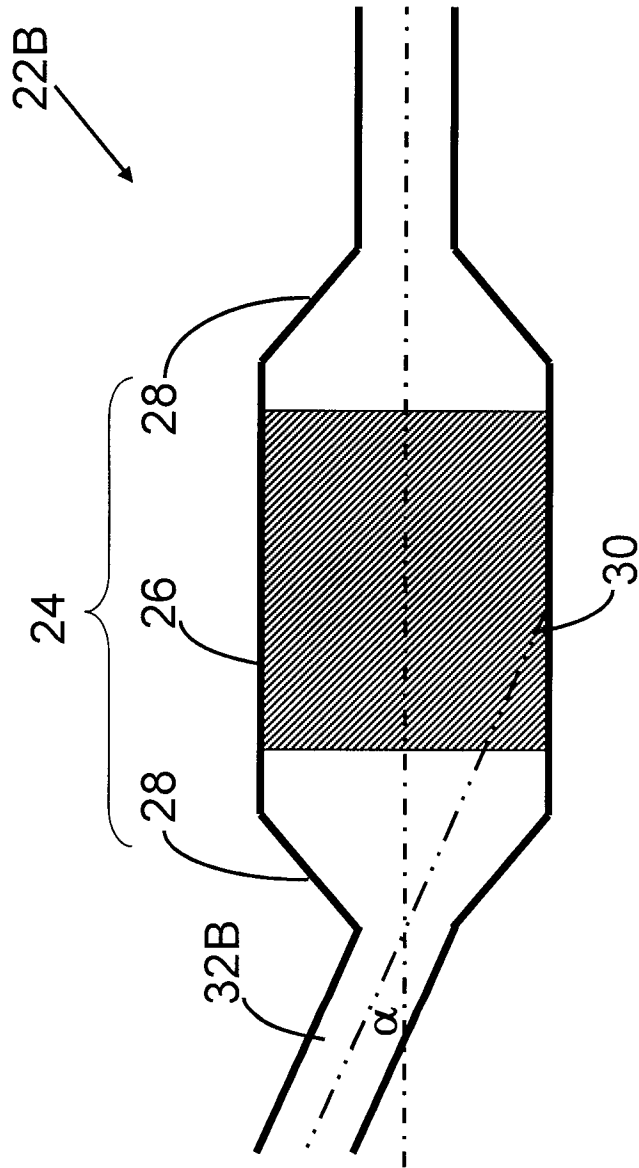

Fig. 2

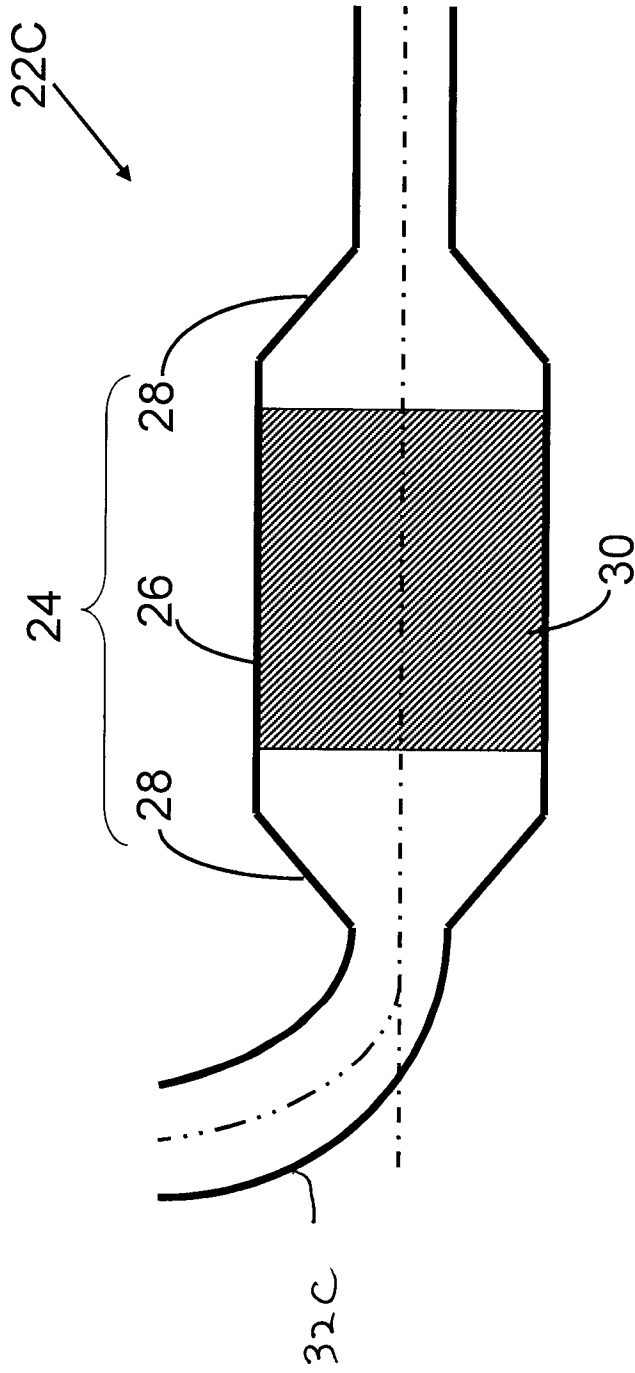

Fig. 3

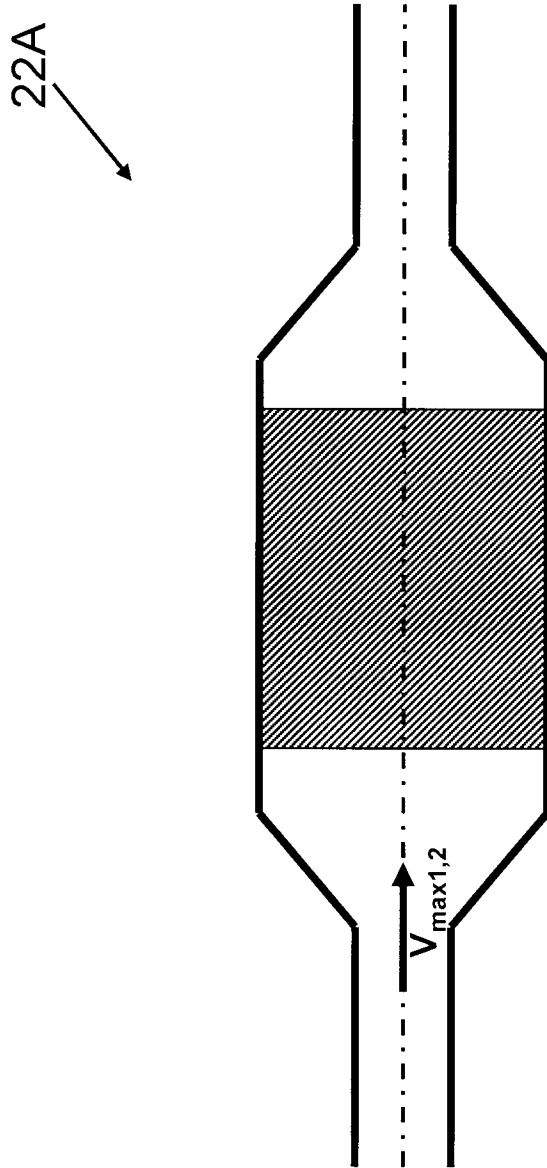

Fig. 4

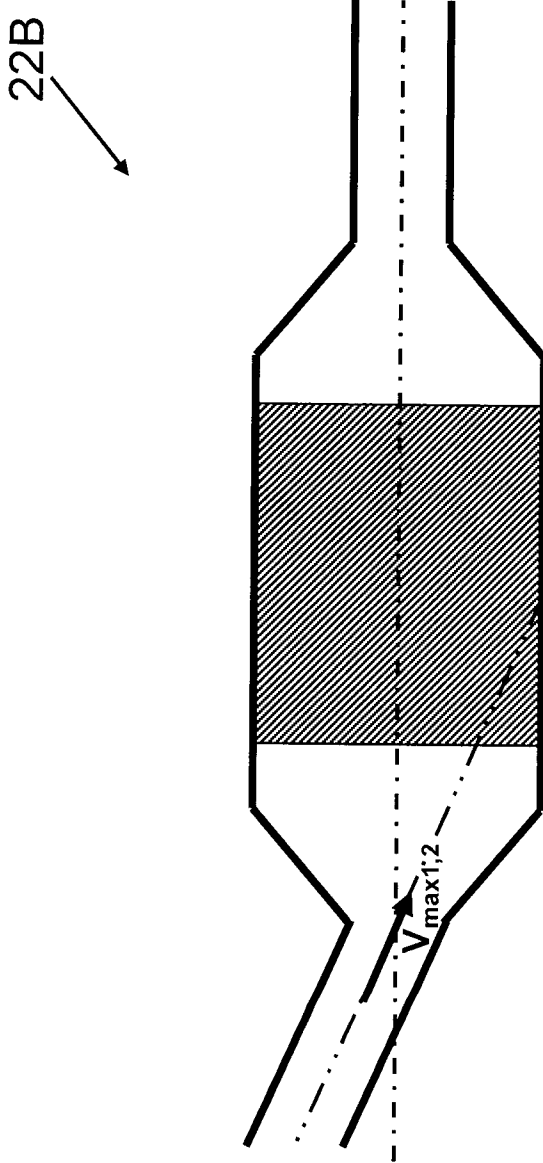

Fig. 5

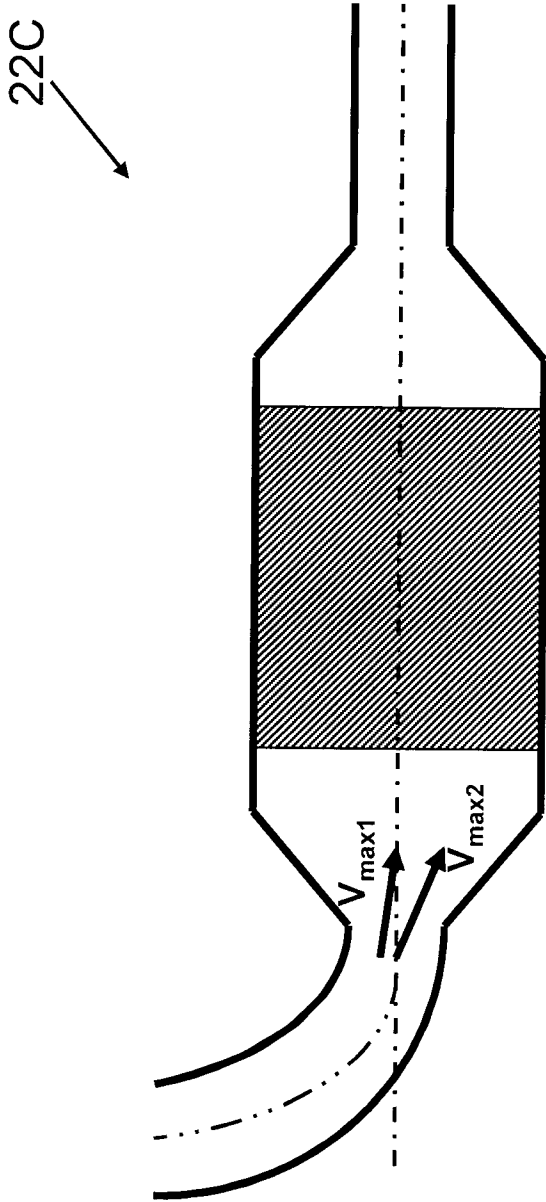

Fig. 6

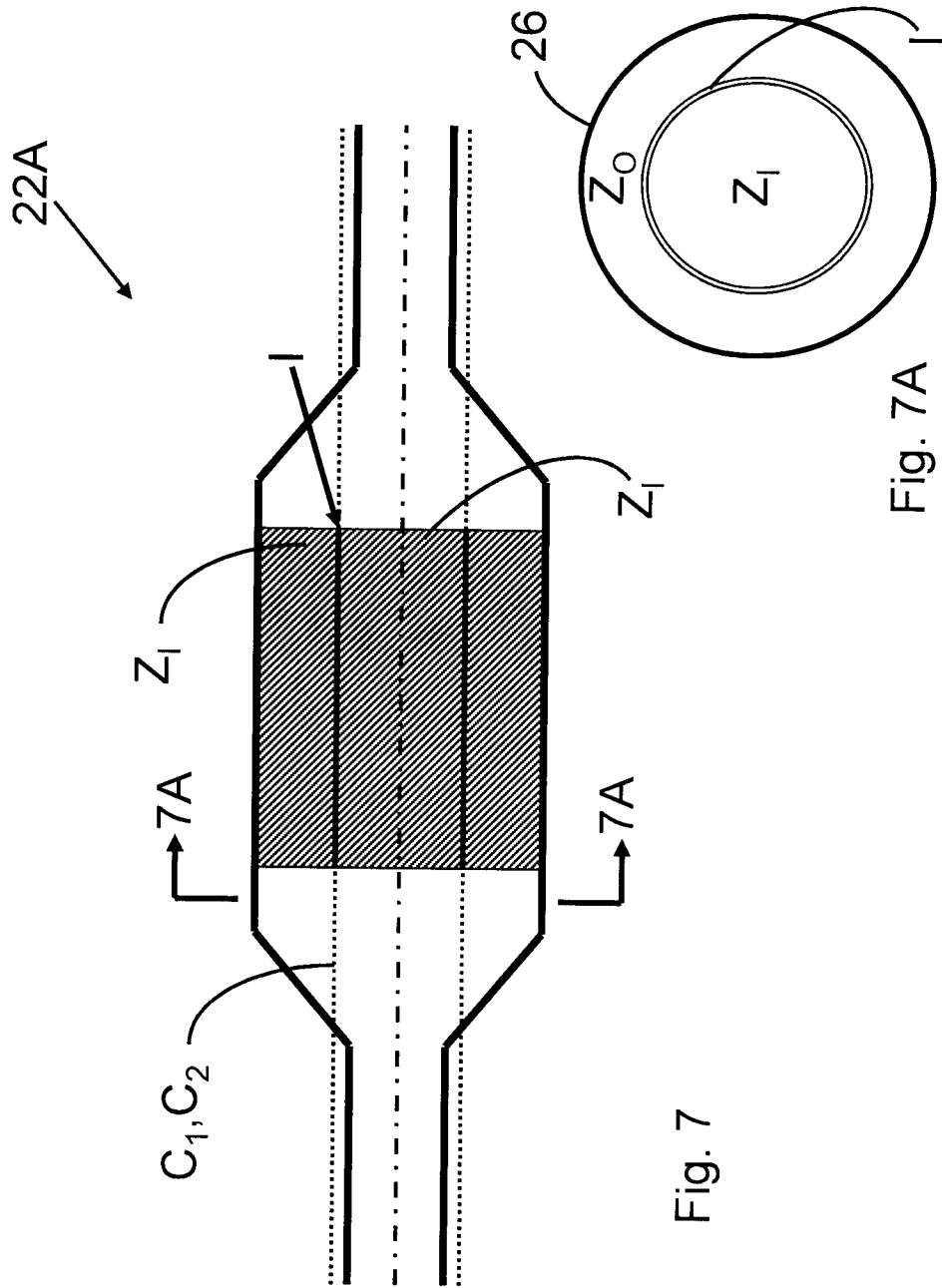

Fig. 7

Fig. 7A

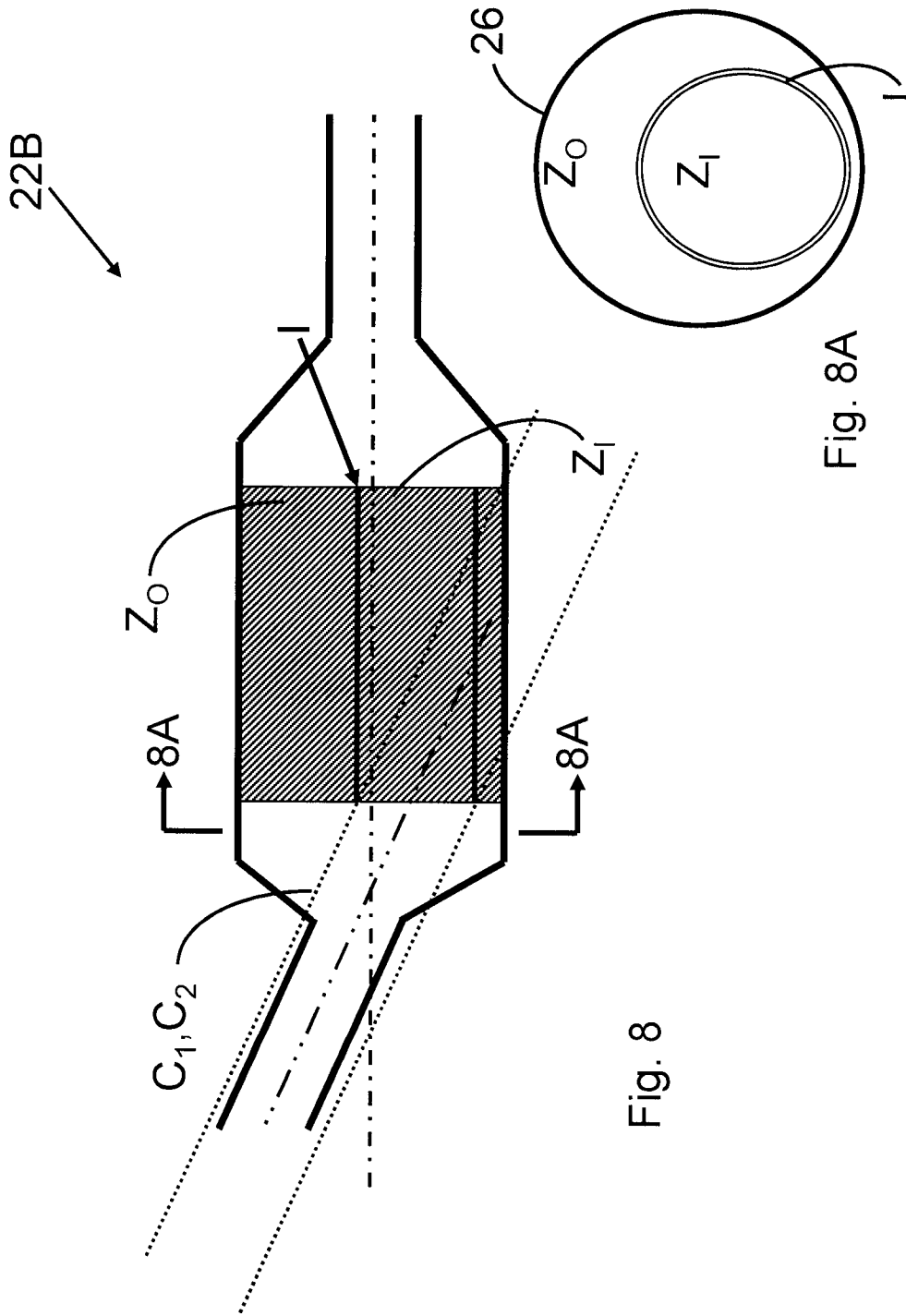

Fig. 8

Fig. 8A

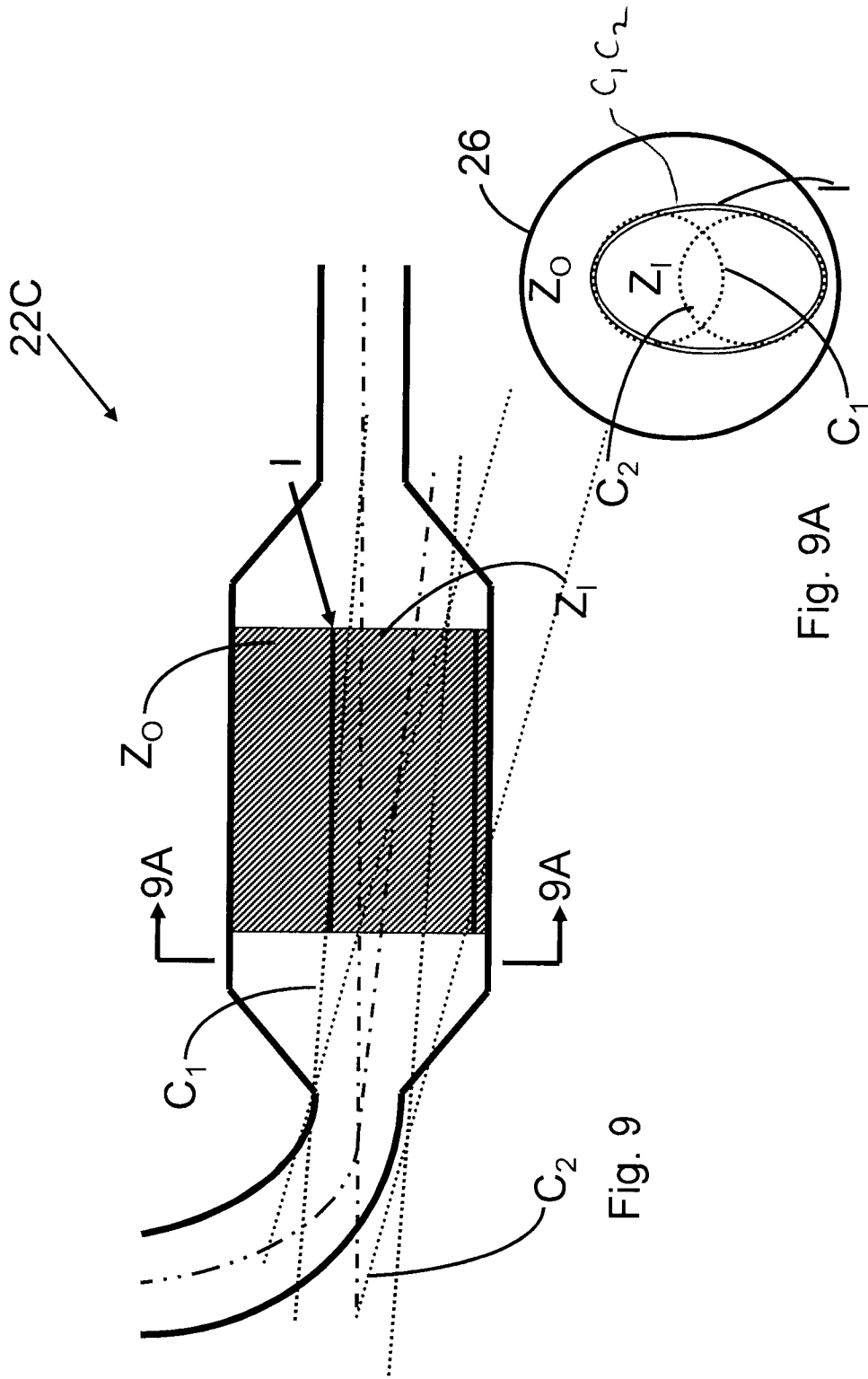

Fig. 9

Fig. 9A

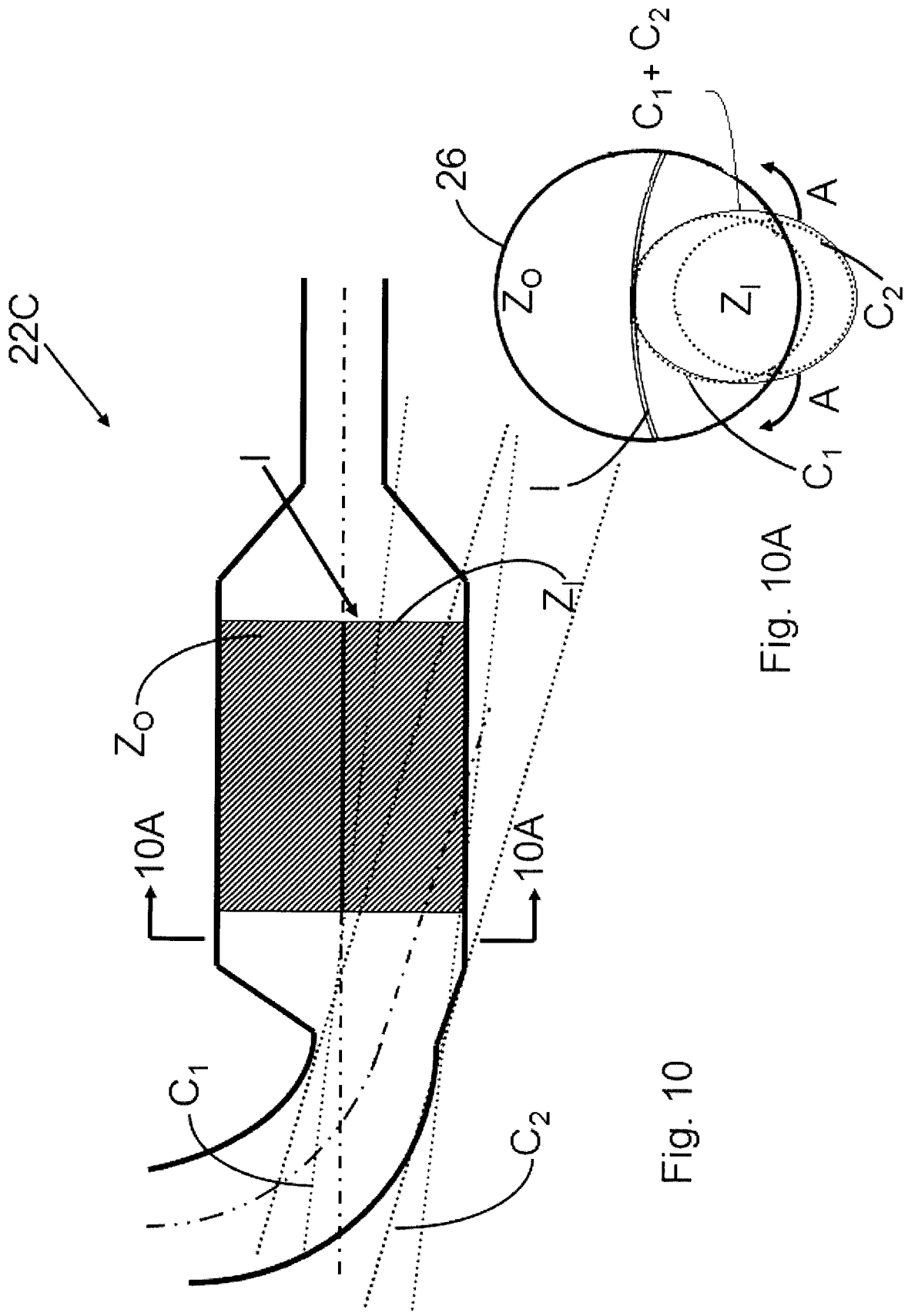

Fig. 10

Fig. 10A

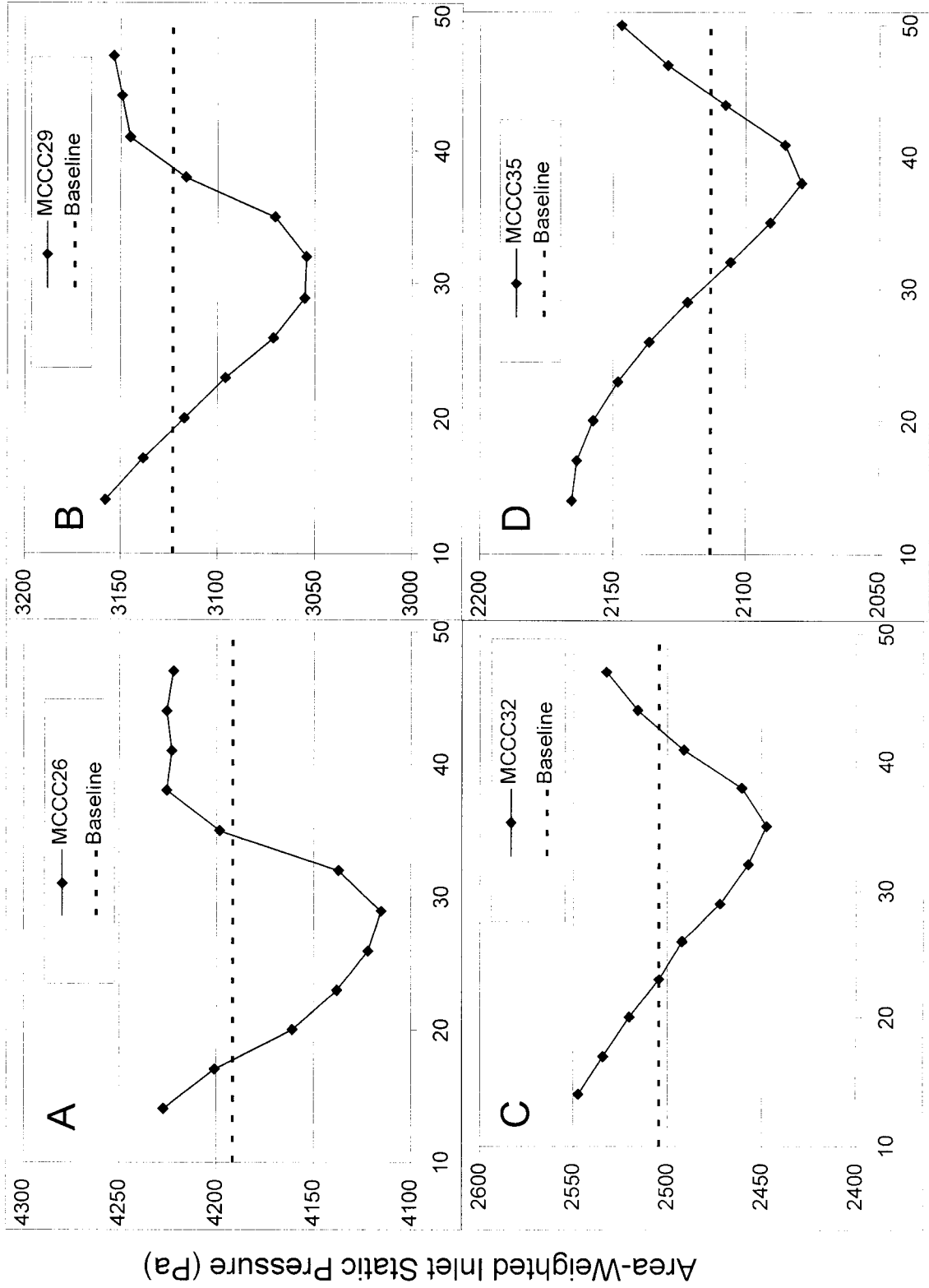

Fig. 11 Insulation Radius (mm)

INTERNATIONAL SEARCH REPORT

International application No.

PCT/CA2014/000032

A. CLASSIFICATION OF SUBJECT MATTER
 IPC: **B01D 53/94** (2006.01), **B01J 35/00** (2006.01), **F01N 3/20** (2006.01), **F01N 3/28** (2006.01)

According to International Patent Classification (IPC) or to both national classification and IPC

B. FIELDS SEARCHED

Minimum documentation searched (classification system followed by classification symbols)
 IPC: **B01D 53/94** (2006.01), **B01D 53/86** (2006.01), **B01J 35/00** (2006.01), **F01N 3/20** (2006.01), **F01N 3/28** (2006.01)

Documentation searched other than minimum documentation to the extent that such documents are included in the fields searched

Electronic database(s) consulted during the international search (name of database(s) and, where practicable, search terms used)
 EPOQUE AND CANADIAN PATENT DATABASE

C. DOCUMENTS CONSIDERED TO BE RELEVANT

Category*	Citation of document, with indication, where appropriate, of the relevant passages	Relevant to claim No.
A	WO2010/022507 A1, Plati et al., 4 March 2010 (04-03-2010) *the entire document*	1 and 2

 Further documents are listed in the continuation of Box C.

 See patent family annex.

* "A" "E" "L" "O" "P"	Special categories of cited documents: document defining the general state of the art which is not considered to be of particular relevance earlier application or patent but published on or after the international filing date document which may throw doubts on priority claim(s) or which is cited to establish the publication date of another citation or other special reason (as specified) document referring to an oral disclosure, use, exhibition or other means document published prior to the international filing date but later than the priority date claimed	"T" "X" "Y" "&"	later document published after the international filing date or priority date and not in conflict with the application but cited to understand the principle or theory underlying the invention document of particular relevance; the claimed invention cannot be considered novel or cannot be considered to involve an inventive step when the document is taken alone document of particular relevance; the claimed invention cannot be considered to involve an inventive step when the document is combined with one or more other such documents, such combination being obvious to a person skilled in the art document member of the same patent family
--------------------------------------	---	--------------------------	--

Date of the actual completion of the international search
 15 May 2014 (15-05-2014)

Date of mailing of the international search report
 22 July 2014 (22-07-2014)

Name and mailing address of the ISA/CA
 Canadian Intellectual Property Office
 Place du Portage I, C114 - 1st Floor, Box PCT
 50 Victoria Street
 Gatineau, Quebec K1A 0C9
 Facsimile No.: 001-819-953-2476

Authorized officer
 James McCarthy (819) 994-0411

INTERNATIONAL SEARCH REPORT
Information on patent family members

International application No.
PCT/CA2014/000032

Patent Document Cited in Search Report	Publication Date	Patent Family Member(s)	Publication Date
WO2010022507A1	04 March 2010 (04-03-2010)	WO2010022507A1 AU2009287378A1 CA2772126A1 CN102203393A EP2329118A1 EP2329118A4 JP2012500927A KR20110054027A RU2011111507A RU2505688C2 US2010050598A1 US8309032B2 US2013028819A1 US2014072491A1 US2014099246A1	04 March 2010 (04-03-2010) 04 March 2010 (04-03-2010) 04 March 2010 (04-03-2010) 28 September 2011 (28-09-2011) 08 June 2011 (08-06-2011) 29 May 2013 (29-05-2013) 12 January 2012 (12-01-2012) 24 May 2011 (24-05-2011) 10 October 2012 (10-10-2012) 27 January 2014 (27-01-2014) 04 March 2010 (04-03-2010) 13 November 2012 (13-11-2012) 31 January 2013 (31-01-2013) 13 March 2014 (13-03-2014) 10 April 2014 (10-04-2014)