

(19) World Intellectual Property Organization
International Bureau



(43) International Publication Date
10 January 2002 (10.01.2002)

PCT

(10) International Publication Number
WO 02/02007 A1

- (51) International Patent Classification⁷: A61B 5/04
 - (74) Agents: WEISZ, Tiberiu et al.; Gottlieb Rackman & Reisman PC, 270 Madison Avenue, New York, NY 10016-0601 (US).
 - (21) International Application Number: PCT/US01/04006
 - (81) Designated States (*national*): AE, AG, AL, AM, AT, AU, AZ, BA, BB, BG, BR, BY, BZ, CA, CH, CN, CR, CU, CZ, DE, DK, DM, DZ, EE, ES, FI, GB, GD, GE, GH, GM, HR, HU, ID, IL, IN, IS, JP, KE, KG, KP, KR, KZ, LC, LK, LR, LS, LT, LU, LV, MA, MD, MG, MK, MN, MW, MX, MZ, NO, NZ, PL, PT, RO, RU, SD, SE, SG, SI, SK, SL, TJ, TM, TR, TT, TZ, UA, UG, UZ, VN, YU, ZA, ZW.
 - (22) International Filing Date: 8 February 2001 (08.02.2001)
 - (25) Filing Language: English
 - (26) Publication Language: English
 - (30) Priority Data: 09/609,558 30 June 2000 (30.06.2000) US
 - (84) Designated States (*regional*): ARIPO patent (GH, GM, KE, LS, MW, MZ, SD, SL, SZ, TZ, UG, ZW), Eurasian patent (AM, AZ, BY, KG, KZ, MD, RU, TJ, TM), European patent (AT, BE, CH, CY, DE, DK, ES, FI, FR, GB, GR, IE, IT, LU, MC, NL, PT, SE, TR), OAPI patent (BF, BJ, CF, CG, CI, CM, GA, GN, GW, ML, MR, NE, SN, TD, TG).
 - (71) Applicant: CARDIAC SCIENCE, INC. [US/US]; 16931 Millikan Avenue, Irvine, CA 92606 (US).
 - (72) Inventors: ZHANG, Xu-Sheng; 1561 Mesa Drive, Apt 72, Santa Ana Heights, CA 92707 (US). LIN, Dongping; 13 Glenn, Irvine, CA 92620 (US).
- Published:
— with international search report

[Continued on next page]

(54) Title: A CARDIAC ARRHYTHMIA DETECTOR USING ECG WAVEFORM-FACTOR AND ITS IRREGULARITY

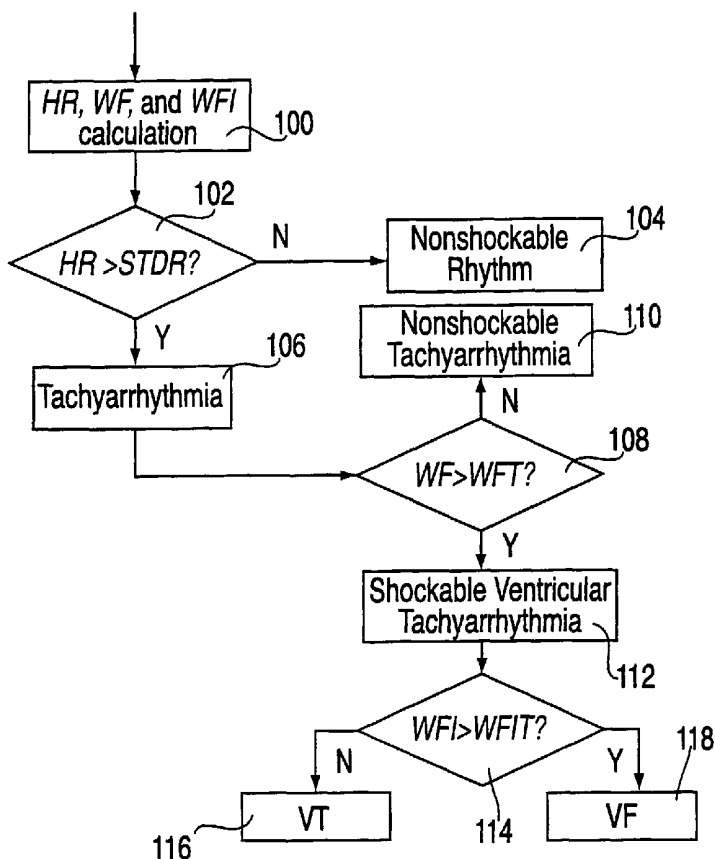

(57) Abstract: A cardiac monitor is provided that monitors the condition of the heart of a cardiac patient and generates signals indicating one of several conditions, such as supraventricular tachycardia, ventricular tachycardia (116) and ventricular fibrillation (118). In order to generate these signals, the ECG from the patient is analyzed to determine a certain interval and heart rate, as well as a waveform factor and a waveform factor irregularity. The waveform factor is derived from the average of the ECG amplitudes during a cardiac interval and the peak value of the ECG during the same interval. Preferably, a running average is calculated over several intervals. This waveform factor is then used to detect shockable ventricular arrhythmia. The waveform factor irregularity is indicative of the variability of the waveform factor and is used to differentiate between ventricular tachycardia and ventricular fibrillation.



WO 02/02007 A1



For two-letter codes and other abbreviations, refer to the "Guidance Notes on Codes and Abbreviations" appearing at the beginning of each regular issue of the PCT Gazette.

A CARDIAC ARRHYTHMIA DETECTOR USING ECG WAVEFORM-FACTOR AND ITS IRREGULARITY

BACKGROUND OF THE INVENTION

A. Field of Invention

5 The present invention relates generally to a cardiac arrhythmia detector in a prosthesis such as an internal or external cardiac defibrillator and pacemaker. More specifically, such a detector comprises a microprocessor used to perform an arrhythmia detection algorithm that detects and analyzes an ECG waveform factor and its irregularity for promptly and accurately discriminating among various types of cardiac arrhythmias, 10 including ventricular fibrillation (VF), ventricular tachycardia (VT), supraventricular tachycardia (SVT), or other arrhythmias.

B. Description of the Prior Art

Sudden cardiac arrest (SCA) accounts for about 76% of sudden non-traumatic deaths in adults and about 50% of all cardiac deaths. Approximately 350,000 Americans 15 experience SCA each year with only about 5% national survival rate. Even in hospital, the percentage of patients who survive SCA is not encouraging. This percentage has remained stable at approximately 15%, and has not improved in the last 30 years. Thus SCA still represents a major and unresolved public health problem.

Ventricular tachyarrhythmia (which includes ventricular fibrillation (VF) and ventricular tachycardia (VT)) is the most common initial incidence of SCA. Unlike other life-threatening conditions such as cancer or AIDS, there is an effective, inexpensive and standard therapy for SCA: timely cardioversion/defibrillation applied by a cardiac stimulator device. Early timely cardioversion/defibrillation (i.e., immediately after onset) is the key to survival, since the chances of success are reduced by 10 percent for every minute of delay of the treatment. Death usually follows unless a normal heart rhythm is restored within 5-7 minutes. Therefore, it is the lack of warning, i.e. detection, and the delay for intervention, not a lack of effective treatment, that accounts for the high death rate following SCA.

The most effective means of saving SCA victims outside a hospital consists of widespread deployment of public access defibrillators as suggested by American Heart Association, and wearable automatic external defibrillators. For diagnosed SCA high-risk patients or SCA survivals, implantable cardioverter defibrillator (ICD) is also an effective treatment. For in-hospital SCA, self-monitoring, self-evaluating, and self-defibrillating monitors, such as fully automatic external defibrillator/monitor Powerheart® (Cardiac Science, Inc., Irvine, CA), and automatic defibrillator module plugged into the existing modular monitoring systems, are the expected effective tools. For both implantable and external automatic defibrillators, the tachyarrhythmia detection algorithm plays the key role for the device's safety, reliability, effectiveness, ease of use, extent of automatic operations, and widespread acceptance. Prompt and accurate detection of VT and VF is still a major challenge in the defibrillation art.

Different tachycardias require different electrical therapies: no electrical therapy needed for the conditions like sinus rhythm, sinus tachycardia (ST), and supraventricular tachycardia (SVT); a comparatively low-energy cardioversion for VT; and a high-energy defibrillation shock for VF. Therefore, the challenge for an effective and successful
5 arrhythmia detector is to discriminate these three types of arrhythmias reliably and accurately. A cardiac device can then treat the appropriate condition on an “as-needed” basis. In this way, the false shocks caused by SVT and ST can be avoided, since it causes unnecessary patient distress, and may initiate VT or VF when none previously existed. Moreover, unnecessary treatment applied by an ICD also wastes power.

10 Differentiating VT from VF makes it allow the treatment of tachyarrhythmias with the lowest energy levels, least painful electrical stimulation pulses, and potentially the most effective therapies. For implantable devices where power source energy and patient tolerance to repeated cardioversion/defibrillation shocks are both limited, therefore, discrimination among these three types of arrhythmias is necessary and
15 important.

Among the methods most widely used for detection of VT & VF in antitachycardia devices is heart rate (*HR*), and the rate of change of rate or suddenness of onset of tachycardias. Rate stability and sustained high rate also are suggested as additional criteria. Rate and rate-related measures are not a reliable criterion because of
20 difficulty in separating SVT, VT, and VF, due to the overlap of the heart rate for these arrhythmias and the likelihood of missing an R-wave trigger (i.e., ECG dropout) during VF with rapidly changing peak amplitudes.

Another known criterion, the probability density function which was used as the original ICD detection scheme to measure of time the signal is away from the isoelectric baseline, is being gradually abandoned due to its lack of specificity for tachyarrhythmia discrimination.

5 Along with rate, shape differentiation between ventricular electrograms during sinus rhythm (SR) and VT and VF is another known criteria that can be expected to provide an accurate discrimination using a morphology-based algorithm with correlation analysis and template matching. However, its shortcoming is the necessity of waveform alignment, which is critical to a proper point-by-point comparison. If the test and
10 template signals are not aligned correctly, the result of the waveform comparison can be erroneous. Moreover, aligning the test and template signals and the calculation programs can be a burdensome and time-consuming problem, especially for implantable cardioverter/defibrillator. Furthermore, more memory is required for storing the test and template signals. Therefore, there is still some difficulties for real-time implementation
15 in defibrillators, especially for ICD.

A method of discriminating among cardiac rhythms of supraventricular and ventricular origin by exploiting the differences in their underlying nonlinear dynamics reflected in the morphology of the waveform is disclosed in Patent US5,645,070, issued to Turcott. A two-channel scatter diagram analysis algorithm for distinguishing VT from VF
20 is disclosed in Patent US5,404,880, issued to Throne. The shortcoming for these methods is still the computationally complex and more memory requirement. Other algorithms for tachyarrhythmia discrimination utilizing statistical methods were also proposed (Thakor et al., Ventricular Tachycardia And Fibrillation Detection By A Sequential Hypothesis Testing

Algorithm, IEEE Trans. Biomed. Eng., 1990, 37:837-843 and Turner et al., Statistical Discriminant Analysis of Arrhythmias Using Intracardiac Electrograms, IEEE Trans. Biomed. Eng., 1993, 40:985-989). However, their effectiveness and practical feasibility still need further investigation.

- 5 Modulation domain function (MDF) is effective in discriminating SVT from ventricular tachyarrhythmias (Mattioni et al., Initial Clinical Experience With A Fully Automatic In-hospital External Cardioverter Defibrillator, PACE 1999, 22:1648-1655). However, SVT with an underlying chronic bundle branch block or with aberrant conduction can result in high MDF values, this method may fail for this kind of rhythm.
- 10 Moreover, MDF cannot differentiate VT from VF.

Currently, AED's in use are 90% sensitive for ventricular tachyarrhythmia and 90-95% specificity for other heart rhythms. For ICD the percentage of patients who are paced or shocked unnecessarily still exceeds 40% of those receiving ICD therapies. Moreover, discrimination of VT from VF is also a difficulty objective to achieve using

15 existing algorithms. A need still exists for discovering additional information from ECG waveform to develop computationally simple method of discriminating SVT, VT, and VF.

In atrial and ventricular tachyarrhythmias, the shapes of the P-waves and QRS-waves are distorted from the normal sinus rate shapes. Nonshockable arrhythmias have

20 different morphology with shockable arrhythmias (VT and VF). In fact, while physicians classify a cardiac rhythm, they examine the morphology of the ECG in addition to the heart rate. The morphological differences of the cardiac waveform are indicative of cardiac condition changes. One simple and quantitative measurement for the

morphological difference is the waveform-factor (*WF*) disclosed in this invention. Based on *WF* and waveform-factor irregularity (*WFI*), one novel cardiac arrhythmia detector is proposed for simultaneously discriminating SVT, VT, and VF.

The new algorithm of present invention as disclosed herein is simple,
5 computationally efficient, effective, and well suited for real-time implementation. Therefore, it offers all the desirable features for the practical application to AED and ICD.

OBJECTIVES AND SUMMARY OF THE INVENTION

The present invention relates to a cardiac device with a detector that applies
10 waveform factor analysis to physiological signals. An example of the application is to respond to the needs of AED and ICD by providing a cardiac arrhythmia detector, which provides a clearer and more reliable indication of the onset of VT and VF than has been available in the prior art.

It is accordingly an objective of the present invention to provide a cardiac device which
15 can distinguish reliably among VT, VF, and a set of conditions comprising normal sinus rhythm (NSR), sinus tachycardia (ST), and other supraventricular tachycardias (SVT).

A further objective of the present invention is to provide such a detector which is capable of correctly and accurately distinguishing in real time among these three kinds of cardiac episodes using an easy-to-implement algorithm with a minimum amount of
20 computation complexity.

An additional object of the present invention is to provide such a detector which quantifies the nature of VT and VF (higher waveform-factor, *WF*, compared to SVT)

and the nature of VF (higher waveform-factor irregularity, *WFI*, compared to VT) in order to achieve a diagnosis.

It is still another further object of the present invention to provide such a detector, which discriminates VT from VF and thereby allowing consideration of lower
5 energy therapies for VT to provide significant energy savings for the battery powered device and improved patient comfort, such as an implantable cardioverter/defibrillator, and at the same time avoiding unnecessary shock to SVT.

These and other objects of the invention are realized by providing a novel cardiac device with an arrhythmia detector, which is capable of reliably and efficiently
10 differentiating VT, VF, and nonshockable SVT and atrial fibrillation (AF). Specifically, the detector of the present invention uses ECG waveform-factor and its irregularity for VT, VF, and SVT separation. According to the present invention, ECG under different cardiac rhythms demonstrates different morphology and different comparative change in waveform, which can be characterized by waveform-factor (*WF*) and waveform-factor
15 irregularity (*WFI*). For nonshockable tachyarrhythmias (such as SVT and atrial fibrillation), their ECG *WF* is lower than that of VT and VF. For VT, its *WFI* is lower than that of VF, since the waveform of VT is more stable and the QRS complexes of VT basically look more similar than that of VF. The detector of the present invention is able to address the limitation of existing algorithms and provide accurate separation among
20 VT, VF, and SVT.

This invention offers a considerable improvement over current methods of analysis by employing a new criterion for reliable separation among VT, VF, and SVT. Particularly, the disclosed *WF* and *WFI* measurements quantify the ECG waveform

morphology and its change, where lower WF indicates nonshockable SVT and AF, and for shockable tachyarrhythmias lower WFI indicates VT, higher WFI indicating VF. In this way, the method determines the precise arrhythmia allowing exact therapeutic selection. Specifically, with proper distinction of SVT, VT, and VF could benefit

5 patients by avoidance of false shock and consideration of lower energy therapies, thereby providing patient comfort and significant energy savings (for ICD).

In comparison with known methods of identifying arrhythmias, for the first time the present invention proposes the concepts of ECG WF and WFI and their estimation methods, and for the first time realizes them in a novel arrhythmia detection algorithm.

10 In one aspect, the present invention provides a cardiac monitor for determining the cardiac condition of a patient, said cardiac monitor including a sensor that senses the intrinsic activity of a patient's heart and generates a corresponding sensed signal; an interval detector that detects the interval associated with a cardiac cycle based on said sensed signal; a waveform factor detector that detects a waveform factor from said

15 sensed signal, said waveform factor being a function of a mean value of said signal during a cardiac cycle and a peak value of said signal during said interval; and a first comparator that compares said waveform factor to a threshold and generates a corresponding first output indicative of the patient's cardiac condition.

The monitor may further include a waveform factor irregularity detector that

20 detects a sudden change in said waveform factor and generates a corresponding second output. A second comparator may be used that compares the second output to a second threshold, said second comparator generating a comparator output indicative of one of ventricular tachycardia and ventricular fibrillation based on said comparator output.

In another aspect of the invention, a method of analyzing the cardiac condition of a patient's heart is provided comprising the steps of sensing a cardiac signal; determining a cardiac interval; determining a waveform factor based on values of said cardiac signal during said cardiac interval and a peak value of said cardiac signal during said interval;
5 comparing said waveform to a first threshold value; and generating respectively a first output indicative of a non-shockable rhythm and a second output indicative of a shockable rhythm. The step of determining a waveform factor may include averaging values of said cardiac signal over said interval and dividing the resulting average by the peak value during said interval to generate an instant waveform factor.

10 The method may further include averaging said instant waveform factor over several intervals to obtain said waveform factor, and a waveform factor irregularity parameter indicative of a sudden change in said waveform factor. According to the method, a tachyarrhythmia signal is generated if said heart rate exceeds a first threshold and one of a shockable and a nonshockable signal is also generated dependent on a
15 magnitude of said waveform factor, wherein a nonshockable signal is indicative of a supraventricular tachycardia and a shockable signal is indicative of a shockable tachycardia.

In another aspect of the invention, one of a fibrillation and a tachycardia signal is generated dependent on a magnitude of said waveform factor irregularity, said
20 fibrillation signal being indicative of a ventricular fibrillation and said tachycardia signal being indicative of a ventricular tachycardia.

The device and method described can be implemented in either an external or an internal antitachyarrhythmia device.

BRIEF DESCRIPTION OF THE DRAWINGS

These and various other features and advantages of the present invention will be more fully understood with reference to the following detailed description taken in conjunction with the accompanying drawings in which:

5 **FIG. 1A** shows a block diagram of a cardioverter/defibrillator constructed in accordance with this invention;

FIG. 1B shows a block diagram of the arrhythmia detector used in the cardioverter/defibrillator of FIG. 1A;

FIG. 1C shows a typical ECG and various parameters thereof used by the present
10 invention;

FIG. 1 is a flowchart for the operation of the arrhythmia detector of FIGS. 1A and 1B using an ECG waveform-factor (*WF*) and a waveform-factor irregularity (*WFI*) in accordance with the principles of the present invention;

FIG. 2 is a flow chart illustrating the method to estimate the waveform-factor,
15 waveform-factor irregularity from ECG signal.

FIGS. 3A-3E illustrate exemplary nonshockable ECG waveforms of sinus rhythm (SR), supraventricular tachycardia (SVT), sinus tachycardia (ST), and atrial fibrillation (AF), along with the corresponding waveform-factor (*WF*) statistical values (mean \pm Standard Deviation, SD).

20 **FIGS. 4A-4E** illustrate exemplary shockable ECG waveforms of ventricular tachycardia (VT), ventricular fibrillation (VF), and fine VF, along with the corresponding *WF* and *WF* irregularity (*WFI*) statistical values (mean \pm SD).

FIG. 5 is an exemplary sample showing the estimated waveform-factor (WF) (every R-wave one WF) changing with rhythms in real time (from SR to VF to SR to SVT).

DETAILED DESCRIPTION OF THE PREFERRED EMBODIMENT

5 In overview, the preferred embodiment of the present invention encompasses an arrhythmia detector with a novel detection algorithm which can be used in conjunction with conventional diagnosis algorithms or can be used to provide stand-alone diagnosis of ECG arrhythmias. The method of the invention enables discrimination between ventricular and supraventricular tachyarrhythmias, and discrimination between different
10 ventricular tachyarrhythmias (VT and VF) as well. For example, the novel detection algorithm of the present invention can be used to independently qualify a cardiac rhythm which has been preliminarily diagnosed as a tachyarrhythmia by rate algorithm as being either a ventricular or supraventricular tachyarrhythmia, and then further classify the diagnosed ventricular tachyarrhythmia as VT or VF.

15 FIG.1A shows a block diagram of a cardioverter/defibrillator device 10 constructed in accordance with this invention. Device 10 may be either an implantable or an external device. The device includes an ECG sensor 12 which covers generically any type of sensor that may be used to acquire an ECG signal from a patient, such as the signal shown in FIG.1C. The ECG signal thus obtained is fed to a band-pass filter 14
20 which filters the signal from the sensor 12 to pass signals in the range of about 3-33 Hz. The filtered analog signal A_n is fed to an analog-to-digital converter (ADC) 16. The ADC samples the analog signal A_n at a predetermined rate, such as 128/second or

256/second, and generates two signals A_i and $ADCzero$. A_i is the amplitude of the current sample, and $ADCzero$ defines the isoelectric baseline of the ECG.

The signals A_i and $ADCzero$ are fed to an arrhythmia detector 18 which determines whether the patient's heart is beating at a sinus rhythm or whether an
5 arrhythmia has been detected that requires therapy. This information is provided to a microprocessor 20 which controls the operation of the device 10. The microprocessor analyzes the signals received from the arrhythmia detector 18 and, if necessary, activates a pulse generator 22. The pulse generator then generates appropriate signals, including for example, cardioversion pulses or defibrillation shocks. These therapy signals are
10 then provided to one or more therapy delivery electrodes 24.

The arrhythmia detector 18 may be incorporated into the microprocessor 20 where it may be implemented by software, however, it is shown here as a separate element for the sake of clarity.

Referring to FIG. 1B, the arrhythmia detector 18 includes a comparator 30, a
15 calculator circuit 32, an R-wave detector 34, heart rate detector 36 and a memory 38. The operation of the device 10 and its arrhythmia detector 18 is now described.

Now referring to FIG. 1 at step 100, the current heart rate (HR), a waveform-factor (WF), and a waveform-factor irregularity (WFI) are calculated from ECG signal by the detector 18, as discussed in more detail below. At step 102, the current HR is
20 compared to a preset tachyarrhythmia detection rate ($STDR$) threshold. If HR rises over $STDR$, then a tachyarrhythmia condition is determined in step 106. Otherwise, normal or supraventricular rhythm is determined in step 104, i.e. a rhythm is determined which

does not require any electrical therapy. A typical value for preset tachyarrhythmia detection rate *STDR* may be about 120 beats per minute.

If tachyarrhythmia is determined in steps 102 and 106 then at step 108 the waveform factor parameter *WF* is compared to a preset waveform-factor threshold
5 (*WFT*). A typical value for the parameter *WFT* may be in the range of 25-35 with 30 (in percentile) being preferable.

If *WF* is larger than the *WFT*, then at step 112 it is determined that the tachyarrhythmia is a shockable ventricular tachyarrhythmia. Otherwise, a nonshockable tachyarrhythmia condition is determined in step 110, including supraventricular
10 tachycardia, atrial fibrillation, etc., and no therapy is applied.

Following the determination at step 112, at step 114 the *WFI* is compared to a pre-set threshold (*WFIT*). A typical value for *WFIT* may be about 10. If the current *WFI* exceeds *WFIT*, then the ventricular tachyarrhythmia is determined to be ventricular fibrillation (VF) at step 118. Otherwise, at step 116 a ventricular tachycardia is
15 determined. As part of steps 116 and 118 appropriate therapy is generated by the pulse generator 22 and fed to the appropriate electrodes (not shown).

The calculations required to determine the variables *HR*, *WF*, and *WFI* are now described in conjunction with in FIG.2. In step 200, some buffers and variables stored in memory 38 are initialized to zero. These include a buffer for storing the values of a
20 predetermined number of consecutive instant waveform-factors (*WF_i*) used to calculate the parameter *WF* by averaging *WF_i*'s; and a buffer for storing consecutive instant waveform-factor irregularities (*WFI_i*) to calculate the *WFI* by averaging *WFI_i*'s. These buffers must be sufficient large to hold *WFNO* data, where *WFNO* indicates the number

of the estimated WF_i 's and WFI_i 's for a predetermined number of R-waves. In a preferred embodiment, the the estimated WF_i 's and WFI_i 's during eight consecutive R waves are stored, it being understood that the parameter $WNFO$ may be selected using other criteria as well.

5 At step 202, the variables $WaveArea$ and $DataNO$ are set to zero every time an R-wave is detected by detector 34. At step 204, a new ECG data A_i is acquired and read into the memory 38 for processing. Before being digitized by the ADC 16 (e.g. 12-bit), the analog ECG signal is filtered with the band-pass filter 14 preferably in the range of 3 to 33 Hz (-3dB). The low-pass section of the filter serves as an anti-aliasing filter and
10 smooths the transitions in the ECG so that the peaks may easily be identified. The highpass section of the filter 14 serves to remove any baseline drift from the signal, so that a separate DC removal stage is not required.

The filtered analog signal A_n is converted by ADC 16 into a corresponding sample A_i and the parameter $ADCzero$ (i.e. isoelectric baseline) is also generated. For
15 example, A 12-bit ADC can fully have 4095 ADC units to represent a bipolar ECG signal sample A_i . Under this situation, an A_i with 2048 ADC units is 0 mV (i.e., $ADCzero$ or isoelectric baseline) in physical value, an A_i with 4095 ADC units is +5 mV, and an A_i with 0 ADC units is -5 mV.

In step 206 the value $ADCzero$ is subtracted from the A_i by comparator 30. Then
20 the absolute value of the difference (i.e. $|A_i - ADCzero|$) is added to the parameter $WaveArea$ and the number of data points $DataNO$ is incremented by one at step 208.

In step 210 the R-wave detector 34 is used to detect the R-wave. The R-wave detector can be implemented using different schemes well known in the art. For

example, if the absolute value of A_i exceeds a threshold that is a function of the peak amplitude of the last R-wave and a fixed threshold, a synchronous R impulse is emitted indicating by its presence that the R-wave is recognized.

At step 212 if an R-wave is not detected, the microprocessor 20 continues to
 5 acquire the next new data A_i (returning to step 204) and process until an R-wave is detected by detector 34.

If an R-wave is detected then the calculator circuit 32 starts calculating the heart rate HR , the waveform factor WF , and waveform factor irregularity WFI parameters. More specifically, in step 214, the calculator circuit 32 calculates the heart rate HR from
 10 a running average of the duration of a prescribed number (e.g. 8) of the latest R-R intervals. Alternatively, a number of R-R intervals are reviewed, any individual interval in exceeding or following below a certain level by a predetermined percentage is discarded and only the remaining intervals are averaged.

At step 216, current R-wave peak value RP_i is selected from the memory 38.
 15 Then in step 218, for current R-R interval, the mean amplitude value $Mean$ is estimated by dividing the $WaveArea$ by $DataNO$.

Next, the current instant waveform-factor (WF_i) is calculated at step 220 using the formula

$$WF_i = Mean/|RP_i| * 100$$

20 WF_i is obtained just from the ECG data acquired in current R-R interval, therefore, it is called the instant WF for characterizing the ECG waveform. To obtain a relatively stable WF , the following steps 222-226 average the latest $WFNO$ (e.g. 8) data of WF_i 's in the buffer of memory 36. At step 222, current WF_i is added to WF_iSum

(storing the sum of the latest $WFNO$ data of the WF_i 's) and the oldest WF_i (i.e. WF_{i-WFNO}) is subtracted.

The WF_i -Buffer is allocated as follows: WF_{i-WFNO} , $WF_{i-(WFNO-1)}$, $WF_{i-(WFNO-2)}$, ..., WF_{i-2} , WF_{i-1} . At step 224, the WF_i -Buffer is updated by shifting left one data, and the current WF_i is stored into the position of WF_{i-1} and the oldest one WF_{i-WFNO} shifted out and discarded. Thus, WF_i -Buffer always keeps the latest $WFNO$ (e.g. 8) data of the WF_i 's. At step 226, the value of WF is calculated by averaging the latest $WFNO$ data of the WF_i 's.

The instant waveform-factor irregularity (WFI_i) is calculated at step 228 using the formula:

$$WFI_i = |WF_{i-1} - WF_{i-2}| / WF_{i-1} * 100$$

where, WF_{i-1} in the WF_i -Buffer is the current WF_i and WF_{i-2} the previous one, since WF_i -Buffer has been updated in step 224. This parameter WFI_i provides an indication of a sudden change of parameter WF_i .

Next, the waveform irregularity parameter WFI is calculated. At step 230, the current WFI_i is added to WFI_iSum (storing the sum of the latest $WFNO$ data of the WFI_i 's) and the oldest WFI_i (i.e. the one No. $WFNO$ in the buffer, WFI_{i-WFNO}) is subtracted. The WFI_i -Buffer is allocated as follows: WFI_{i-WFNO} , $WFI_{i-(WFNO-1)}$, $WFI_{i-(WFNO-2)}$, ..., WFI_{i-2} , WFI_{i-1} . At step 232, the WFI_i -Buffer is updated by shifting left one data, and the current WFI_i is stored into the position of WFI_{i-1} and the oldest one WFI_{i-WFNO} shifted out and discarded. Thus, WFI_i -Buffer always keeps the latest $WFNO$ data of the WFI_i 's. At step 234, the value of WFI is calculated by averaging the latest $WFNO$ data of the WFI_i 's.

At step 236, the estimated parameters HR , WF , and WFI are used for arrhythmia determination as discussed above at steps 102 to 118 in Fig. 1. After finishing arrhythmia discrimination on current cardiac episode, the algorithm starts next operation cycle by returning to step 202. The HR , WF , and WFI are re-computed (updated) in real time every R-R interval (i.e., on an interval-by-interval basis).

As demonstrated above, the novel arrhythmia detector proposed in present invention has following advantages:

1) It is computationally simple, easy to implement by software or hardware (either in analog electronics, or with low computational requirements on a digital microprocessor). All the processing is done using integer arithmetic without requiring excessive computing power. The calculation of parameters WF and WFI does not require too much memory either. Only two buffers are required, each holding $WFNO$ (e.g. 8) data of the parameters WF_i and WFI_i .

2) Multiple functions are performed, including discriminating shockable VT and VF from nonshockable SVT (the main cause of false therapy), differentiating VT and VF, thereby providing specific therapies for different arrhythmias.

3) It can track closely the change of the ECG signal rapidly in real time and identify any possible VF or VT for timely suitable therapy (i.e., high-energy defibrillation, low-energy cardioversion, etc.). Unnecessary shock therapy for SVT is also avoided since the arrhythmia detection is performed every R-R interval.

4) ECG dropout is tolerated. As illustrated in FIG.2, if one R-wave is missed, more ECG data is collected for calculating WF_i . Since WF_i is an average based on a predetermined number of ECG samples ($DataNO$), it will still be an accurate factor

characterizing the ECG waveform morphology, even if its collected over a longer segment (two R-R intervals). Measuring cycle length (i.e., heart rate *HR*) is dependent on an accurate sensing of R-wave.

Although the present invention has been described in detail hereinabove, it
5 should be clearly understood that many alternatives to the embodiments and/or
modifications of the basic inventive concepts herein taught which may appear to those
skilled practitioner will still fall within the spirit and scope of the present invention, as
defined in the claims. For examples, at step 108 (or 114), by checking whether a
predetermined number or proportion of a series of preceding *WF*'s (or *WFI*'s) are greater
10 than the preset threshold *WFT* (or *WFIT*) to determine the arrhythmia is shockable
tachyarrhythmia(or VF)(e.g. at least 4 of the preceding 6 estimated *WF*'s (or *WFI*'s) over
the preset threshold); or by using *WF* (or *WFI*) related concepts, such as "onset" to detect
arrhythmias; or at step 226 (or 234), by discarding a percentage of *WF_i*'s (or *WFI_i*'s)
prior to averaging them to get *WF* (or *WFI*) (e.g., discarding the largest and smallest
15 ones among *WFNO* data; or first discarding the one with the largest difference to the
average of these *WFNO* data, and then among the remaining *WFNO-1* data discarding
the one with the largest difference to the average of the remaining *WFNO-1* data, finally
averaging the remaining *WFNO-2* data); or just triggering the calculation of *WFI* at step
112 each time the detected *WF* exceeds a pre-set threshold *WFT*.

20 The present invention will be further understood according to the following
description of specific examples.

EXAMPLES

The ECG signals were digitized in the rate of 128 samples per second with a 12-bit A/D resolution, and as described above in FIGS. 1A, 1B, 1 and 2.

First, some nonshockable rhythms and their WF statistical values (mean \pm SD) are illustrated in FIGS.3A-3E. An example of sinus rhythm (SR) suddenly changing into supraventricular tachycardia (SVT) is shown in FIG. 3A. An example of sinus tachycardia (ST) is shown in FIG. 3B, an example of atrial fibrillation (AF) with high heart rate (HR) in FIG.3C, an example of SVT from patient with left bundle branch block (LBBB) is shown in FIG.3D, and another example of SVT with aberrant conduction is shown in FIG.3E. The WF values for each of these rhythms are all below one threshold (such as 30 percent). For these nonshockable rhythms, the waveform-factor irregularity (WFI) does not need to be calculated. The value of parameter WF for these waveforms is listed below:

	<u>WAVEFORM TYPE</u>	<u>WF</u>	<u>FIG.</u>
15	SINUS RHYTHM	9 \pm 1	3A
	SVT	15 \pm 7	3A
	ST	12 \pm 1	3B
	AF WITH HIGH HR	15 \pm 1	3C
	SVT WITH LBBB	15 \pm 1	3D
20	SVT	24 \pm 1	3E

Several shockable tachyarrhythmias and their WF and WFI statistical values are illustrated in FIGS. 4A-4E. More specifically, an example of SVT suddenly changing

into VT is shown in FIG.4A, an example of VT is shown in FIG.4B, an example of VT changing into VF is shown in FIG.4C, an example of VF is shown in FIG.4D, and an example of fine VF is shown in FIG.4E.

Values for the parameters *WF* and *WFI* for the waveforms of FIGS. 4A-4E are listed below:

	<u>WAVEFORM TYPE</u>	<u>WF</u>	<u>WFI</u>	<u>FIG.</u>
	SVT	25±2	N.A.	4A
	VT	68±1	1±1	4A
	VT	66±4	2±1	4B
10	VT	64±2	5±2	4C
	VF	58±4	37±8	4C
	VF	54±4	33±10	4D
	fine VF	43±5	47±12	4E

The *WF* values for these arrhythmias are all over one threshold (such as 30 percentile). Moreover the *WFI* values for VF and fine VF are much higher than for VT. By using *WFI*, VF and VT can be thus differentiated from each other. More particularly in step 114 in Fig. 1 the value of threshold *WFIT* may be in the range of 5-15 with 10 (in percentile) being preferable.

By comparing FIG.3A and FIG.4A, it is found that sudden onset of a high rate is not a reliable means of discriminating SVT from VT, since sometime SR can suddenly change into SVT just as SVT suddenly changes into VT. However, by using *WF*, SVT can be easily differentiated from VT, since SVT has a lower *WF* value. For every R-

wave detected one WF value is calculated by averaging the latest eight instant waveform-factors (WF_i). FIG.5 demonstrates how WF tracks the changes of rhythms (from SR to VF to SR to SVT) during one 5-min recording. The onset of shockable VF definitely can be identified by a WF threshold (such as 30 percentile) from other
5 nonshockable rhythms.

Although body surface ECG used by AED is utilized here as examples to illustrate the invention, epicardiac or intracardiac electrogram used by ICD or pacemaker are also suited for being analyzed by the present invention.

Numerous modifications may be made to this invention without departing from its scope
10 as defined in the appended claims.

CLAIMS

We claim:

1. A cardiac monitor for determining the cardiac condition of a patient comprising:
 - a sensor that senses the intrinsic activity of a patient's heart and generates a corresponding sensed signal;
 - an interval detector that detects the interval associated with a cardiac cycle based on said sensed signal;
 - a waveform factor detector that detects a waveform factor from said sensed signal, said waveform factor being a function of a mean value of said signal during a cardiac cycle and a peak value of said signal during said interval; and
 - a first comparator that compares said waveform factor to a threshold and generates a corresponding first output indicative of the patient's cardiac condition.

2. The cardiac monitor of claim 1 further comprising a waveform factor irregularity detector that detects a sudden change in said waveform factor and generates a corresponding second output.

3. The cardiac monitor of claim 2 further comprising a second comparator that compares said second output to a second threshold, said second comparator generating a comparator output indicative of one of ventricular tachycardia and ventricular fibrillation based on said comparator output.

4. The cardiac monitor of claim 2 wherein said waveform factor irregularity detector further includes an averager that averages said waveform factor irregularity over several cardiac cycles to generate an irregularity average indicative of one of a tachycardiac and ventricular fibrillation condition.

5. The cardiac monitor of claim 1 wherein said cardiac monitor is external.

6. The cardiac monitor of claim 1 wherein said cardiac monitor is implantable.

7. The cardiac monitor of claim 1 wherein said cardiac monitor is incorporated into an internal defibrillator.

8. The cardiac monitor of claim 1 wherein said cardiac monitor is incorporated into an external defibrillator.

9. The cardiac monitor of claim 1 wherein said sensor signal is an ECG.

10. A cardiac detector device adapted to indicate a cardiac condition of a patient that can be treated by applying electrical therapeutic pulses to the heart, said device comprising:

a sensor adapted to sense an ECG and to generate a corresponding sensed signal;

a heart rate detector that detects a heart rate based on said sensed signal;

a first comparator adapted to compare said heart rate to a first threshold and to generate a tachyarrhythmia indicating signal if said heart rate exceeds said first threshold;

a waveform factor detector adapted to analyze said sensed signal for a cardiac cycle and to generate a waveform factor dependent on a mean of said sensed signal and a peak value of said detected signal during said cardiac cycle; and

a second comparator that compares said waveform factor to a second threshold to generate respectively one of a first output indicative of a nonshockable condition and a second output indicative of a shockable condition.

11. The cardiac detector of claim 10 wherein said waveform factor detector includes a first average calculator that calculates a first average of said sensed signal, an instant waveform factor detector that generates an instant waveform factor from a ratio of said average and said peak value and a summer which sums the instant waveform factors for several cardiac cycles.

12. The cardiac detector of claim 11 wherein said first average calculator calculates a running average over a cardiac cycle.

13. The cardiac detector of claim 10 further comprising a waveform factor irregularity detector that calculates a waveform factor irregularity based in a variability of said waveform factor.

14. The cardiac detector of claim 13 further comprising a third comparator adapted to compare said waveform factor irregularity to a third threshold and to generate respectively one of a ventricular tachycardia signal indicative of ventricular tachycardia and a ventricular fibrillation signal indicative of ventricular fibrillation.

15. The cardiac detector of claim 13 wherein said waveform irregularity detector includes an instant irregularity detector that detects an instant irregularity based on a current and a preceding waveform factor, and a second averager adapted to take an average of said instant irregularity during several cardiac cycles.

16. The cardiac detector of claim 15 wherein said second averager calculates a moving average.

17. A cardiac therapy device adapted to provide selectively shock therapy to a patient, comprising:

a sensor adapted to detect intrinsic activity in the heart and to generate a corresponding sensed signal;

a pulse generator adapted to generate therapy pulses to the heart in response to control signals;

a monitor adapted to classify the condition of the heart and to generate a corresponding heart condition signal; and

a controller adapted to receive said condition signal and to generate in response said control signals;

wherein said monitor includes

an interval detector that detects the interval associated with a cardiac cycle based on said sensed signal;

a waveform factor detector that detects a waveform factor from said sensed signal, said waveform factor being a function of a mean value of said signal during a cardiac cycle and a peak value of said signal during said interval; and

a first comparator that compares said waveform factor to a threshold and generates a corresponding first output indicative of the patient's cardiac condition.

18. The device of claim 17 wherein said monitor further comprises a waveform factor irregularity detector that detects a sudden change in said waveform factor and generates a corresponding second output.

19. The device of claim 18 wherein said monitor further comprises a second comparator that compares said second output to a second threshold, said second comparator generating a comparator output indicative of one of ventricular tachycardia and ventricular fibrillation based on said comparator output.

20. The device of claim 18 wherein said waveform irregularity detector further includes an averager that averages said waveform irregularity over several cardiac cycles to generate an irregularity average indicative of one of a tachycardiac and ventricular fibrillation condition.

21. The device of claim 17 wherein said device is external.
22. The device of claim 17 wherein said device is implantable.
23. The device of 17 wherein said sensed signal is an ECG.
24. A method of analyzing the cardiac condition of a patient's heart comprising the steps of:
 - sensing a cardiac signal;
 - determining a cardiac interval;
 - determining a waveform factor based on values of said cardiac signal during said cardiac interval and a peak value of said cardiac signal during said interval;
 - comparing said waveform to a first threshold value; and
 - generating respectively a first output indicative of a non-shockable rhythm and a second output indicative of a shockable rhythm.
25. The method of claim 26 wherein said step of determining a waveform factor includes averaging values of said cardiac signal over said interval and dividing the resulting average by the peak value during said interval to generate an instant waveform factor.
26. The method of claim 27 further comprising averaging said instant waveform factor over several intervals to obtain said waveform factor.

27. The method of claim 28 further comprising generating a waveform factor irregularity parameter indicative of a sudden change in said waveform factor.

28. The method of claim 29 further comprising detecting a difference between two consecutive waveform factors to determine said waveform factor irregularity.

29. The method of claim 29 further comprising determining a heart rate of said patient.

30. The method of claim 31 further comprising generating a tachyarrhythmia signal if said heart rate exceeds a threshold.

31. The method of claim 32 further comprising generating one of a shockable and a nonshockable signal dependent on a magnitude of said waveform factor, wherein a nonshockable signal is indicative of a supraventricular tachycardia and a shockable signal is indicative of a shockable tachycardia.

32. The method of claim 33 further comprising generating one of a fibrillation and a tachycardia signal dependent on a magnitude of said waveform factor irregularity, said fibrillation signal being indicative of a ventricular fibrillation and said tachycardia signal being indicative of a ventricular tachycardia.

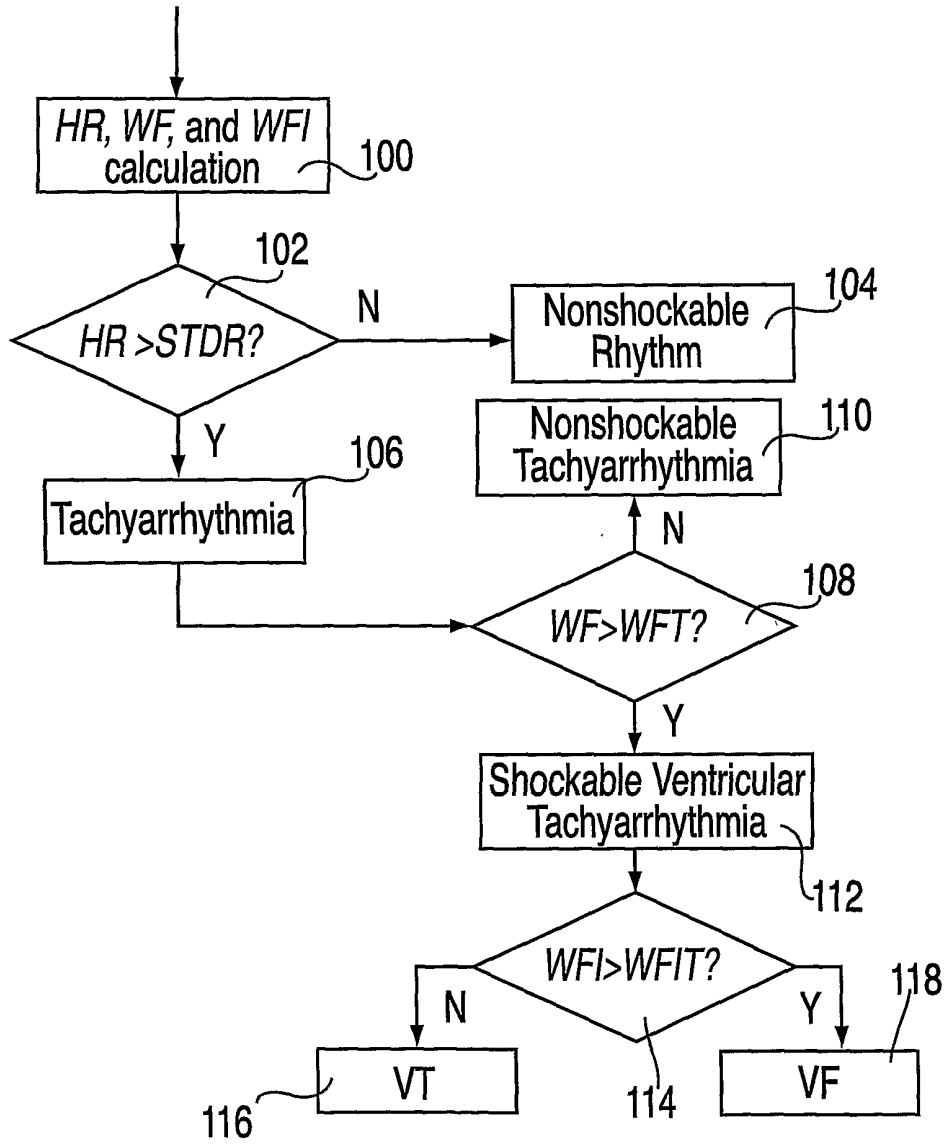

FIG. 1

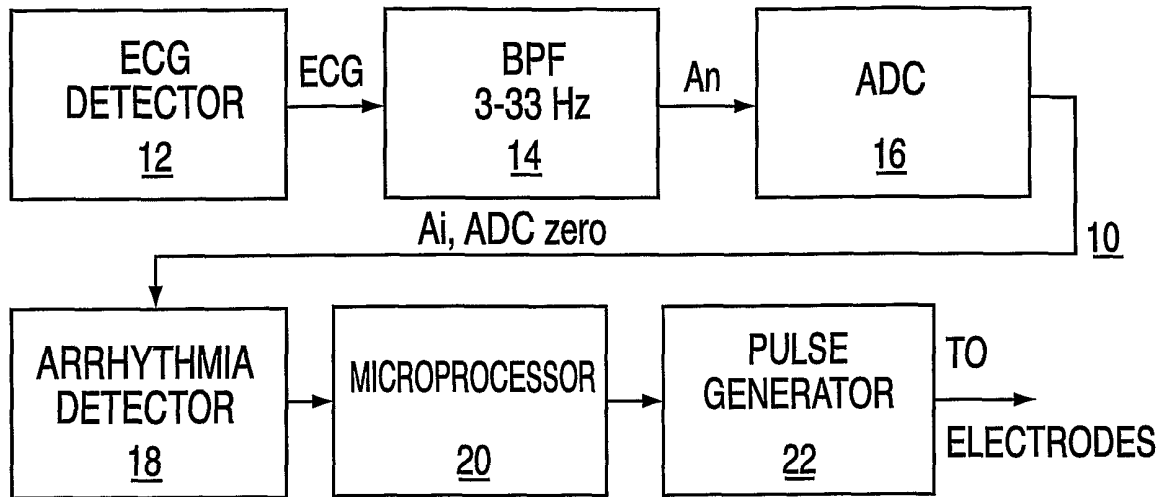

FIG. 1A

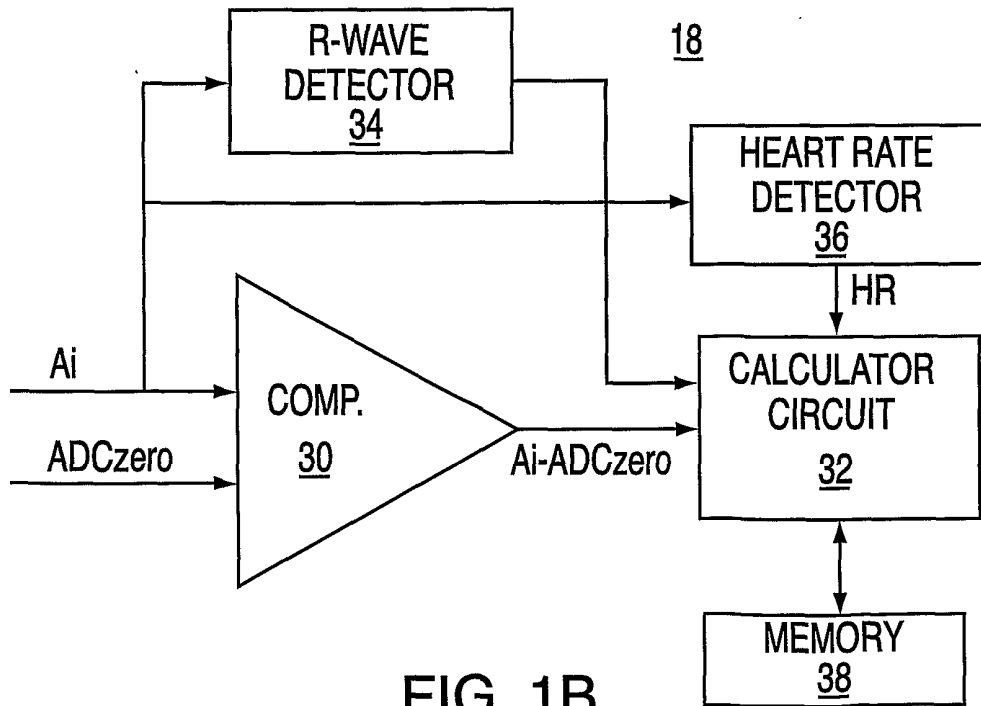

FIG. 1B

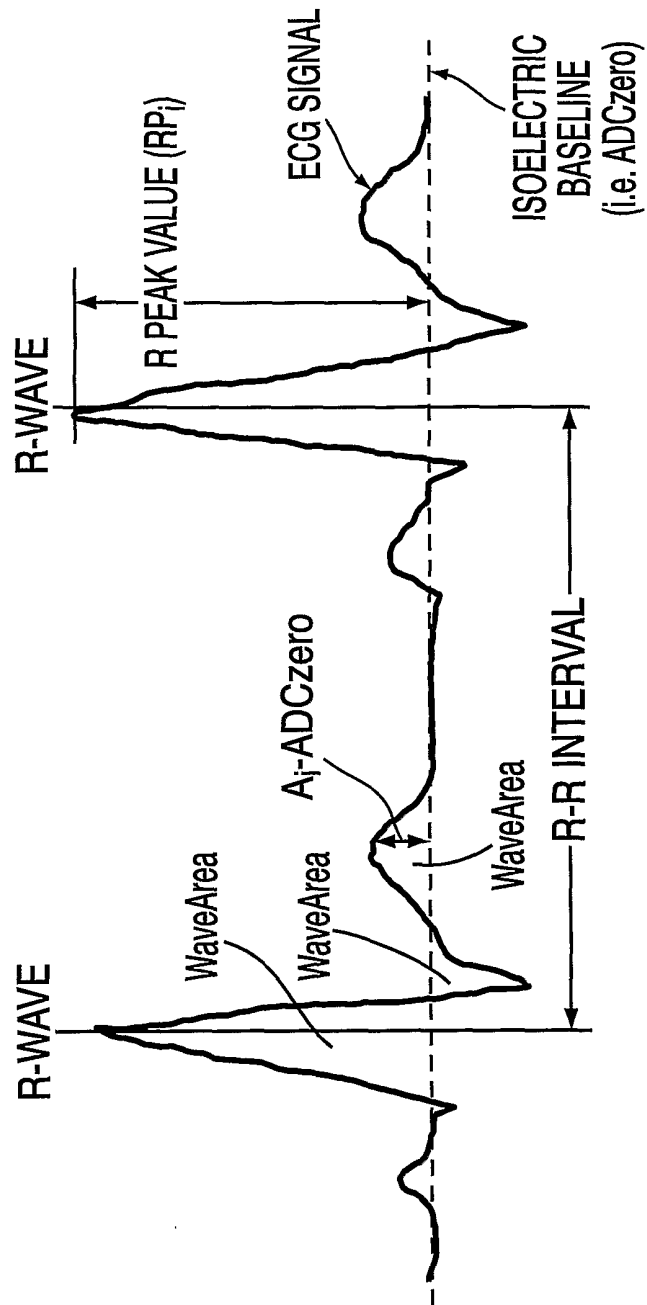

FIG. 1C

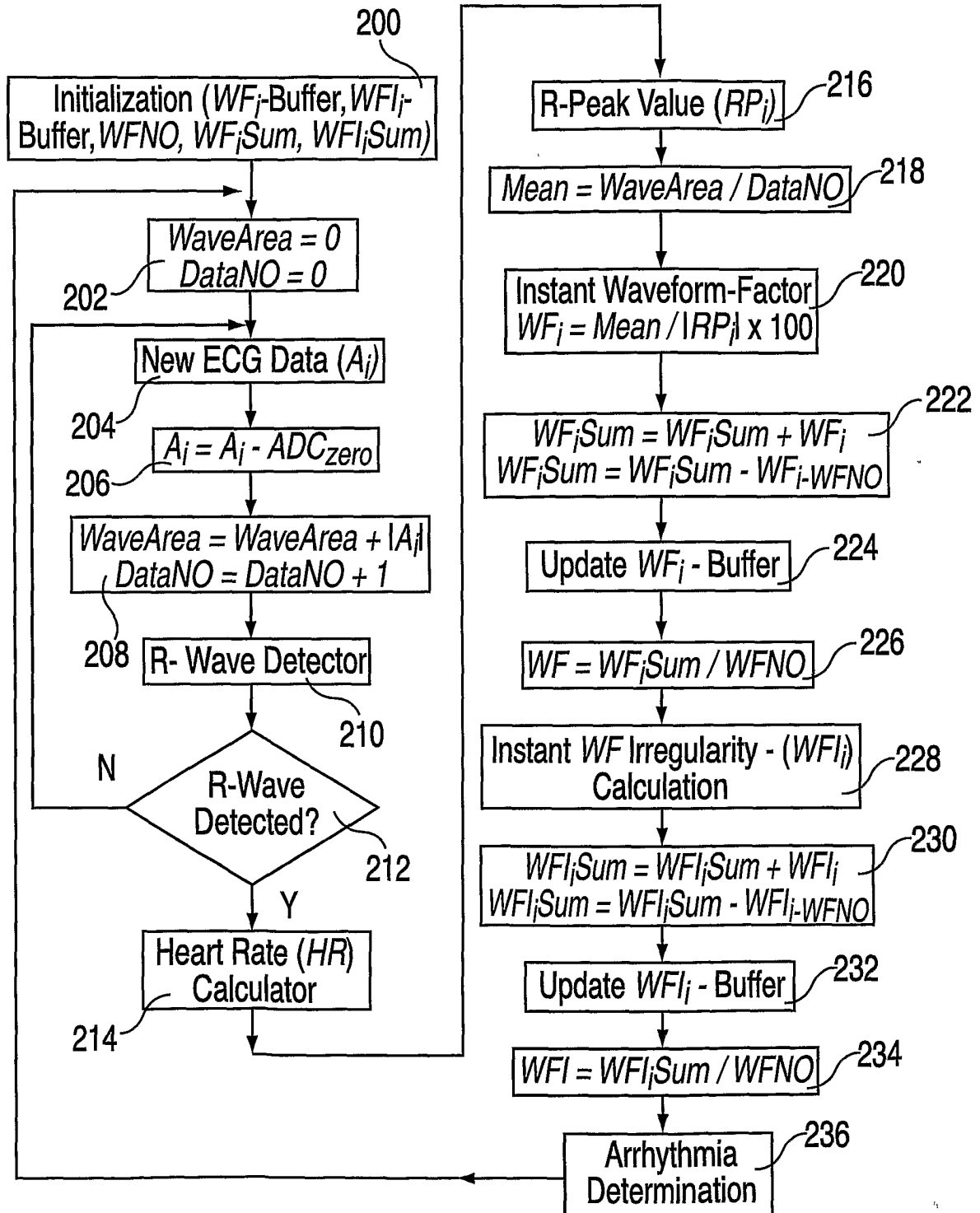

FIG. 2



FIG. 3A

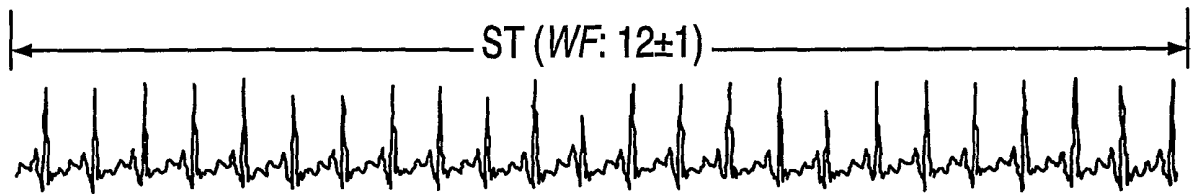

FIG. 3B

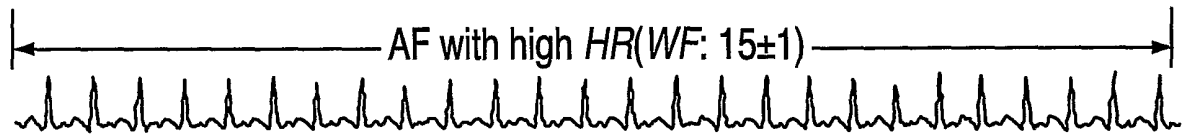

FIG. 3C

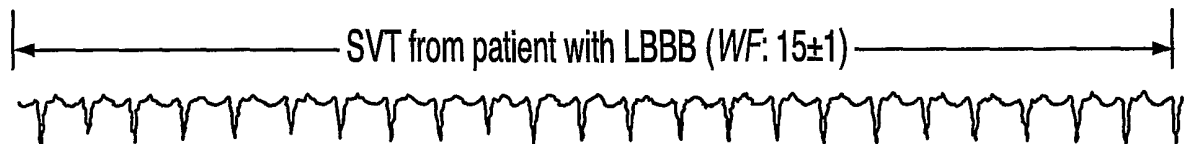

FIG. 3D

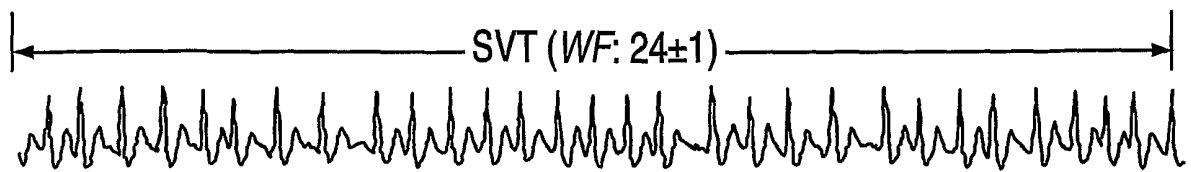

FIG. 3E

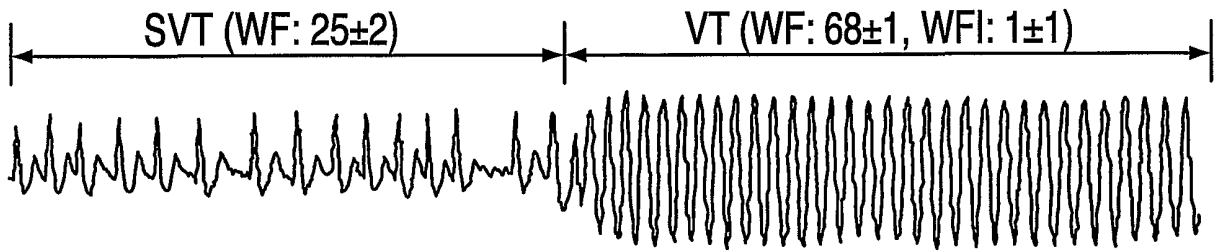

FIG. 4A

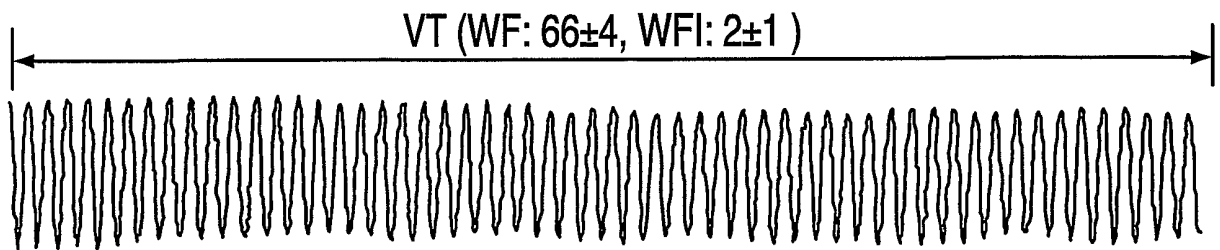

FIG. 4B

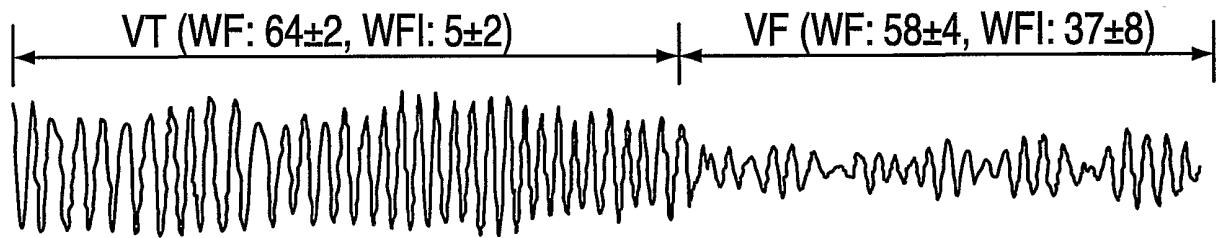

FIG. 4C

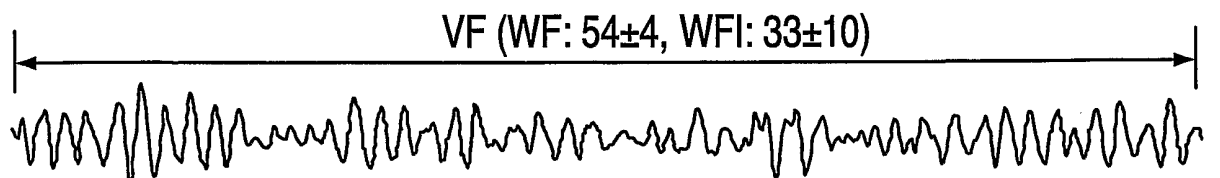

FIG. 4D

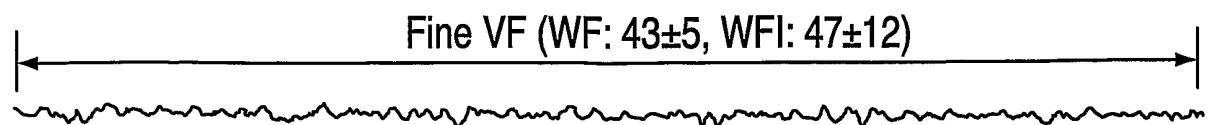

FIG. 4E

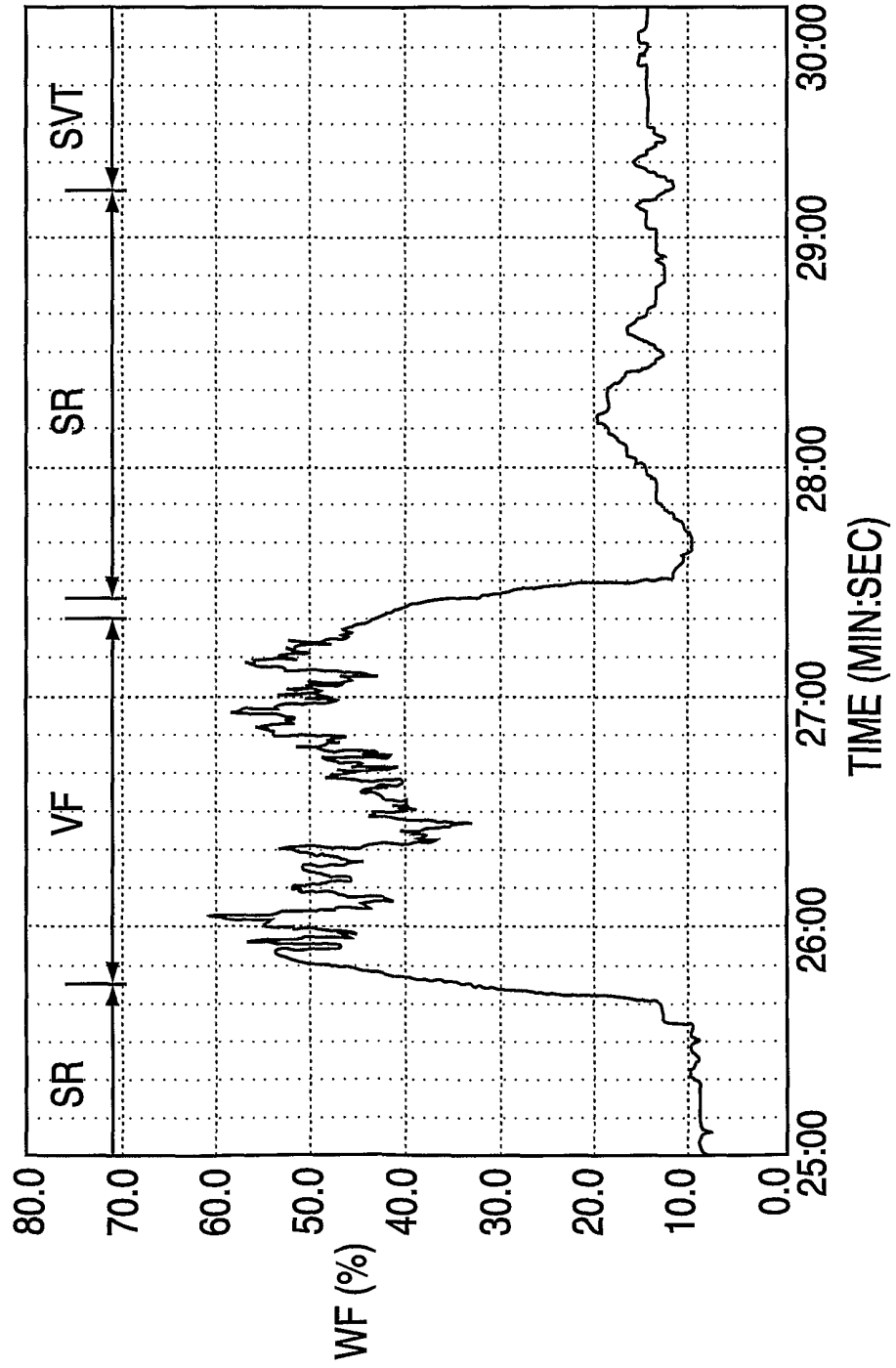

FIG. 5

INTERNATIONAL SEARCH REPORT

International application No.
PCT/US0104006

A. CLASSIFICATION OF SUBJECT MATTER

IPC(7) :A61B 504
US CL :600/518; 607/4

According to International Patent Classification (IPC) or to both national classification and IPC

B. FIELDS SEARCHED

Minimum documentation searched (classification system followed by classification symbols)

U.S. : 600/518; 607/4

Documentation searched other than minimum documentation to the extent that such documents are included in the fields searched

Electronic data base consulted during the international search (name of data base and, where practicable, search terms used)

C. DOCUMENTS CONSIDERED TO BE RELEVANT

Category*	Citation of document, with indication, where appropriate, of the relevant passages	Relevant to claim No.
X	US 5,447,519 A (PETERSON) 05 SEPTEMBER 1995, COL.1, LINE 6, COL.15, LINE 11.	1-4,6-7, 9-20
X	US 5,086,772 A (LARNARD ET AL.) 11 FEBRUARY 1992, COL1, LINE 6, COL.9, LINE 58, COL.12, LINES 15-53.	1-24

Further documents are listed in the continuation of Box C. See patent family annex.

* Special categories of cited documents:	"T" Later document published after the international filing date or priority date and not in conflict with the application but cited to understand the principle or theory underlying the invention
"A" document defining the general state of the art which is not considered to be of particular relevance	"X" document of particular relevance; the claimed invention cannot be considered novel or cannot be considered to involve an inventive step when the document is taken alone
"E" earlier document published on or after the international filing date	"Y" document of particular relevance; the claimed invention cannot be considered to involve an inventive step when the document is combined with one or more other such documents, such combination being obvious to a person skilled in the art
"L" document which may throw doubts on priority claim(s) or which is cited to establish the publication date of another citation or other special reason (as specified)	"G" document member of the same patent family
"O" document referring to an oral disclosure, use, exhibition or other means	
"P" document published prior to the international filing date but later than the priority date claimed	

Date of the actual completion of the international search

10 MAY 2001

Date of mailing of the international search report

31 MAY 2001

Name and mailing address of the ISA/US
Commissioner of Patents and Trademarks
Box PCT
Washington, D.C. 20231

Facsimile No. (703) 305-3230

Authorized officer

FRANCES P. OROPEZA

Telephone No. (703) 605-4355

INTERNATIONAL SEARCH REPORT

International application No.
PCT/US01/04006

Box I Observations where certain claims were found unsearchable (Continuation of item 1 of first sheet)

This international report has not been established in respect of certain claims under Article 17(2)(a) for the following reasons:

1. Claims Nos:
because they relate to subject matter not required to be searched by this Authority, namely:

2. Claims Nos: 25-32
because they relate to parts of the international application that do not comply with the prescribed requirements to such an extent that no meaningful international search can be carried out, specifically:

because they relate to parts of the international application that do not comply with the prescribed requirements to such an extent that no meaningful search can be carried out. Specifically, these dependent claims reference a subsequent claim rather than a prior claim, hence the claim is not clear.

3. Claims Nos:
because they are dependent claims and are not drafted in accordance with the second and third sentences of Rule 6.4(a).

Box II Observations where unity of invention is lacking (Continuation of item 2 of first sheet)

This International Searching Authority found multiple inventions in this international application, as follows:

1. As all required additional search fees were timely paid by the applicant, this international search report covers all searchable claims.

2. As all searchable claims could be searched without effort justifying an additional fee, this Authority did not invite payment of any additional fee.

3. As only some of the required additional search fees were timely paid by the applicant, this international search report covers only those claims for which fees were paid, specifically claims Nos.:

4. No required additional search fees were timely paid by the applicant. Consequently, this international search report is restricted to the invention first mentioned in the claims; it is covered by claims Nos.:

Remark on Protest The additional search fees were accompanied by the applicant's protest.
 No protest accompanied the payment of additional search fees.