

C. SINNING.  
LASTING MACHINE.

No. 456,225.

Patented July 21, 1891.

Fig. 1.

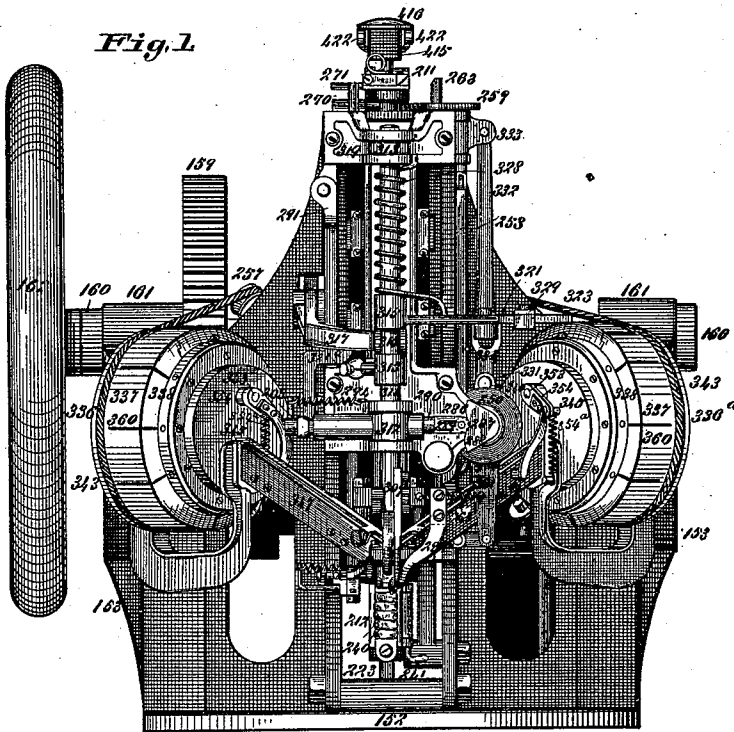
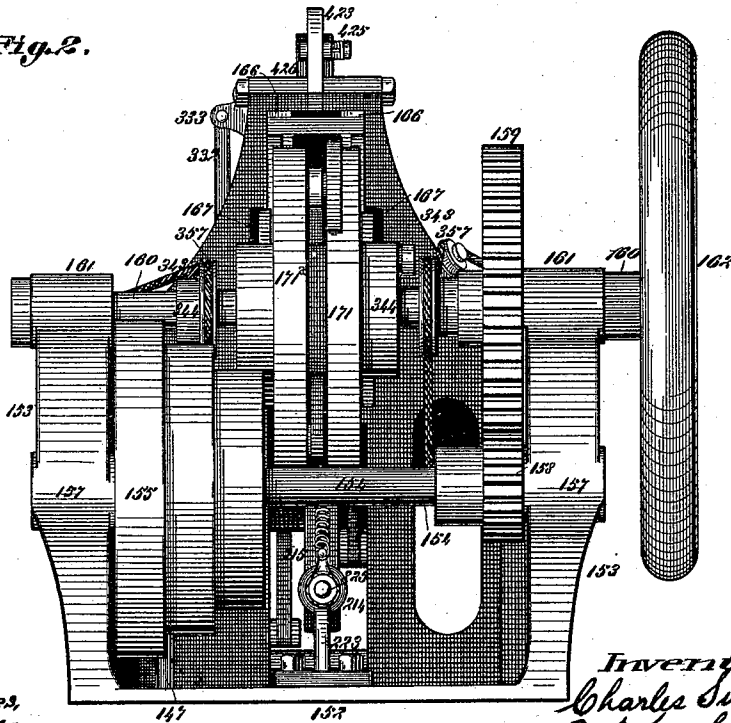

Fig. 2.



Attest,  
Charles Fickles,  
Per. C. Cruise.

Inventor:  
Charles Sinning.  
By Knight Bros.  
Atty

C. SINNING.  
LASTING MACHINE.

No. 456,225.

Patented July 21, 1891.

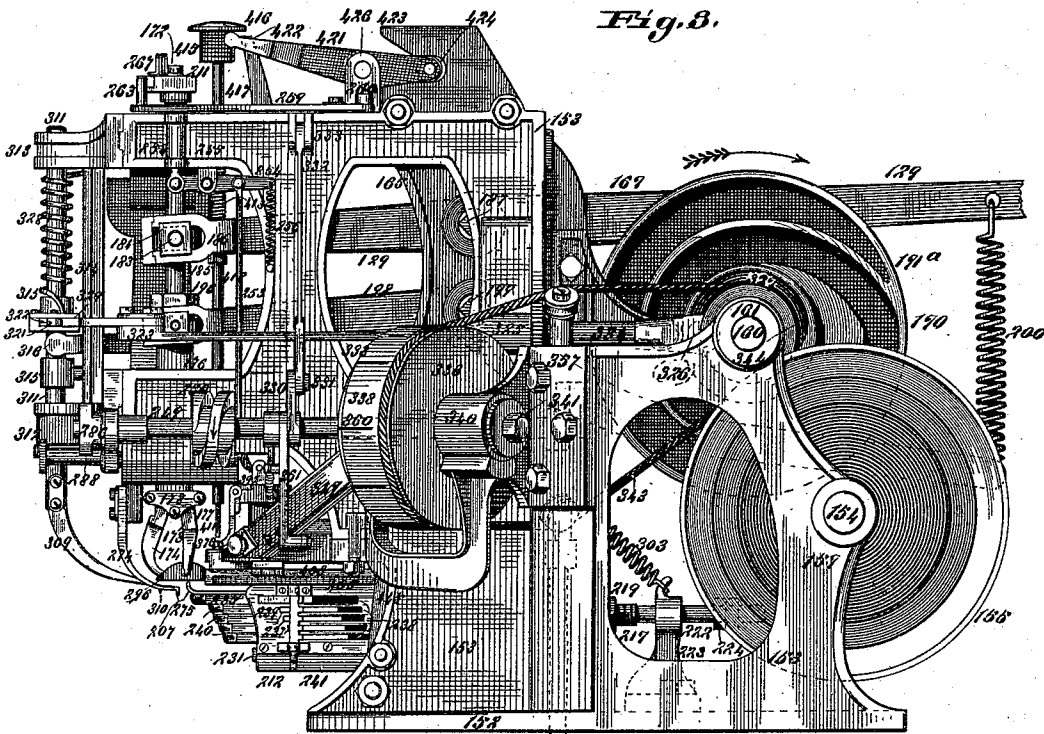

Fig. 3.

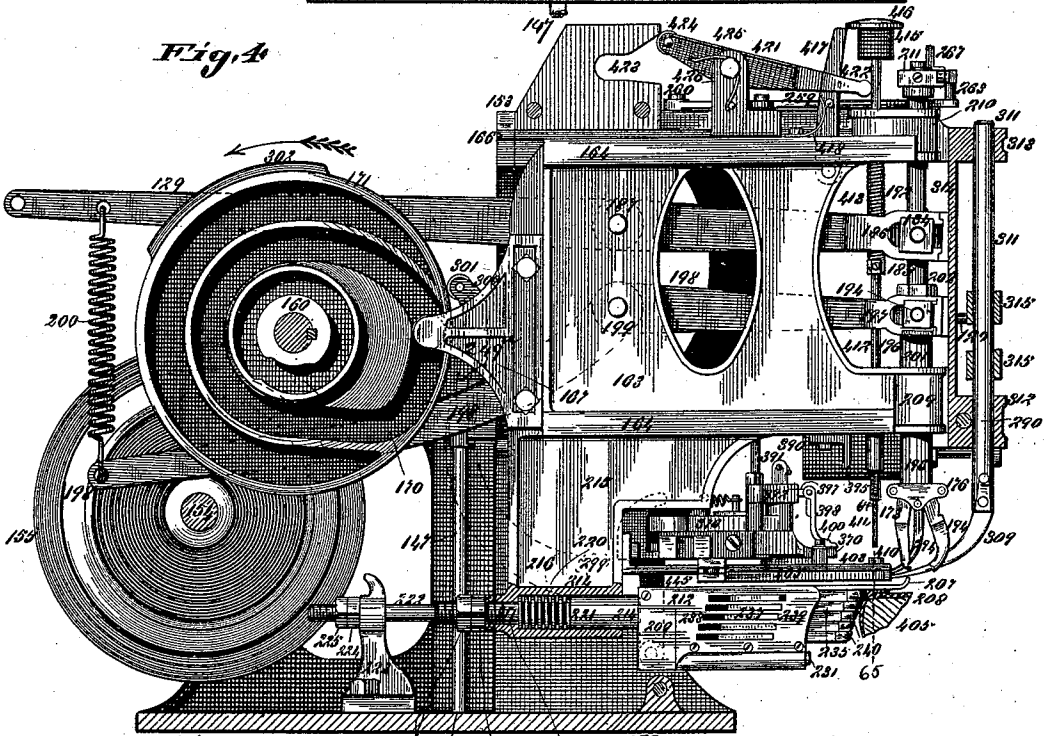

Fig. 4.

Attest;  
Charles Pickles,  
Geo. C. Criss

Inventor:  
Charles Sinning,  
By *Raynought & Co.*  
Attys.

C. SINNING.  
LASTING MACHINE.

No. 456,225.

Patented July 21, 1891.

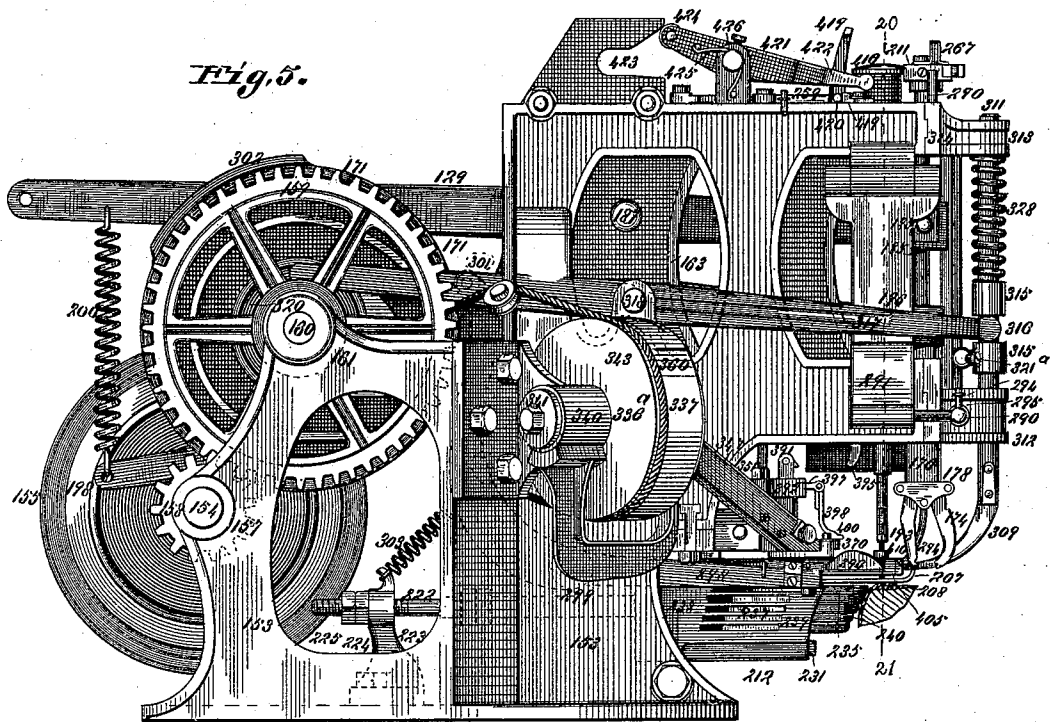

Fig. 5.

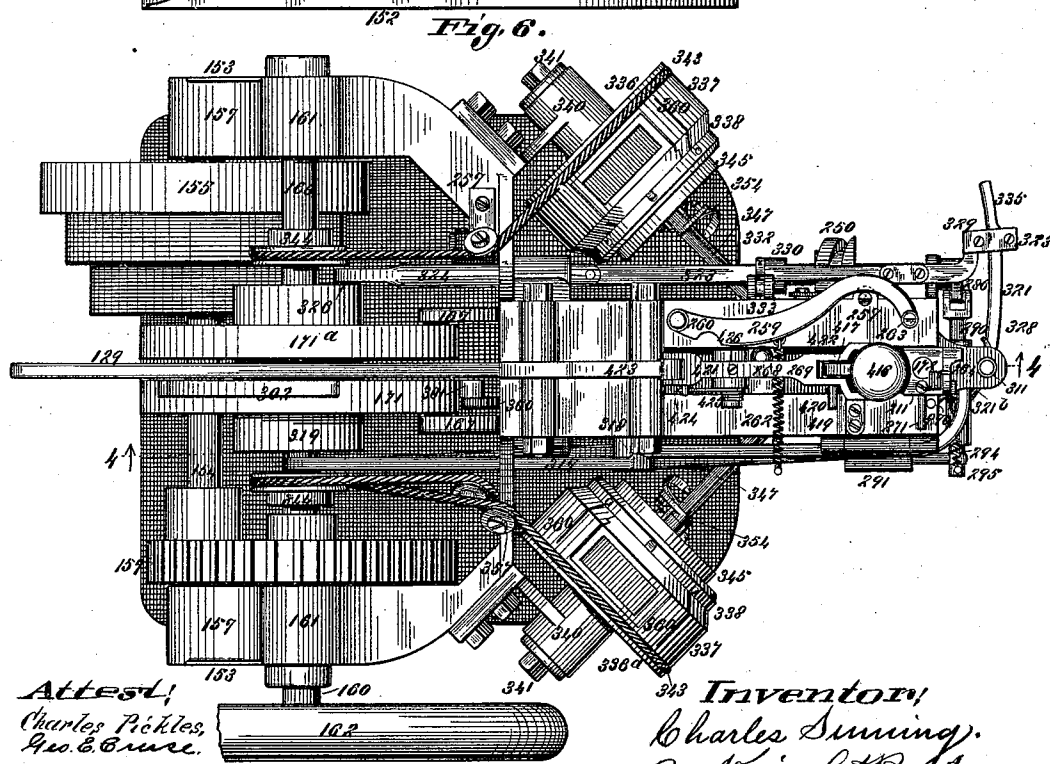

Fig. 6.

Attest,  
Charles Pöckles,  
Geo. E. Bruce.

Inventor,  
Charles Sinning.  
By Knight Bros.  
Attys.

C. SINNING.  
LASTING MACHINE.

No. 456,225.

Patented July 21, 1891.

Fig. 14.

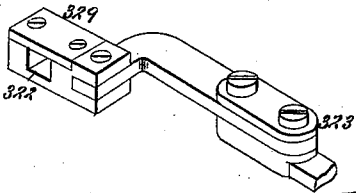

Fig. 7.

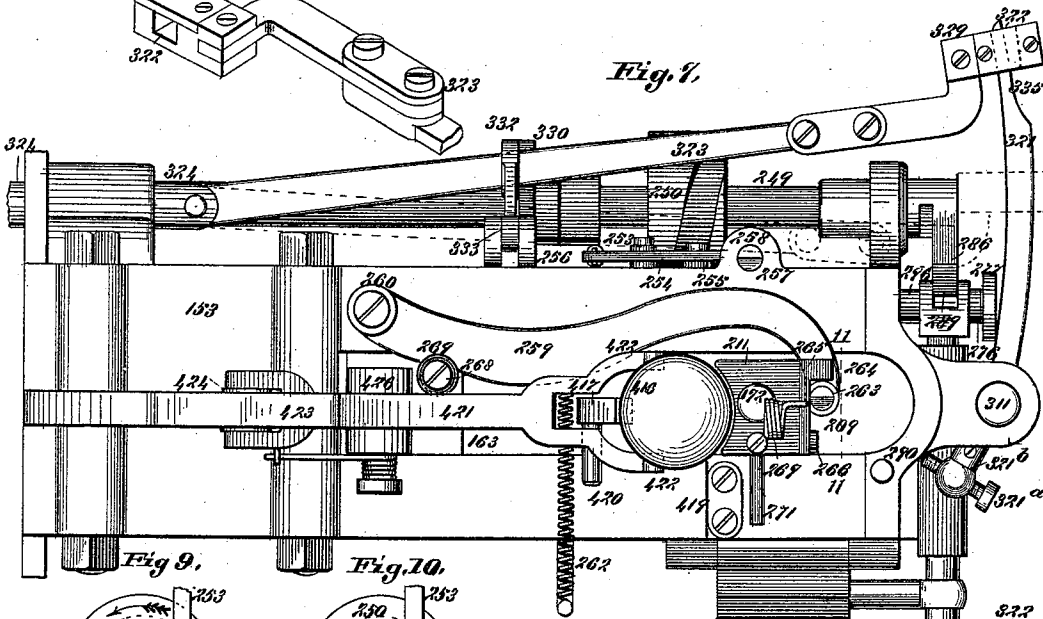

Fig. 9.

Fig. 10.

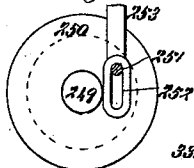
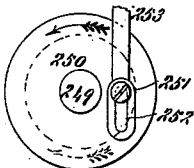

Fig. 8.

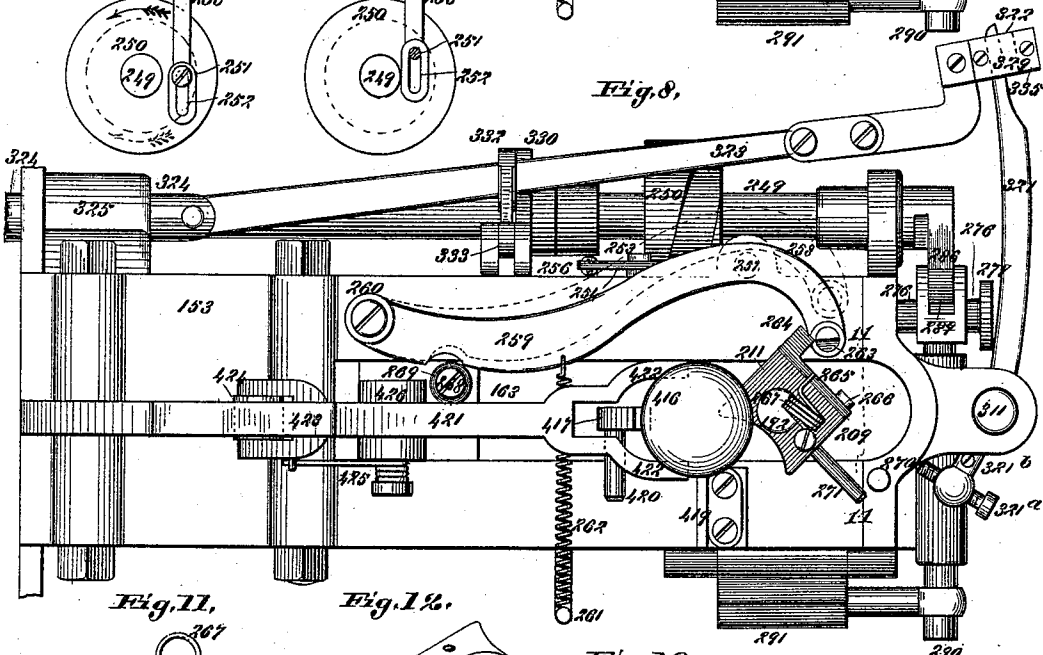

Fig. 11.

Fig. 12.

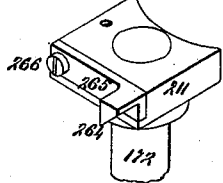
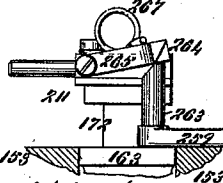
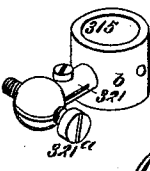

Fig. 13.



Attest!  
Charles Pickles,  
Geo. & Co. Secy.

Inventor:  
Charles Sinning.  
By Knight Bros.  
Atty

C. SINNING.  
LASTING MACHINE.

No. 456,225.

Patented July 21, 1891.

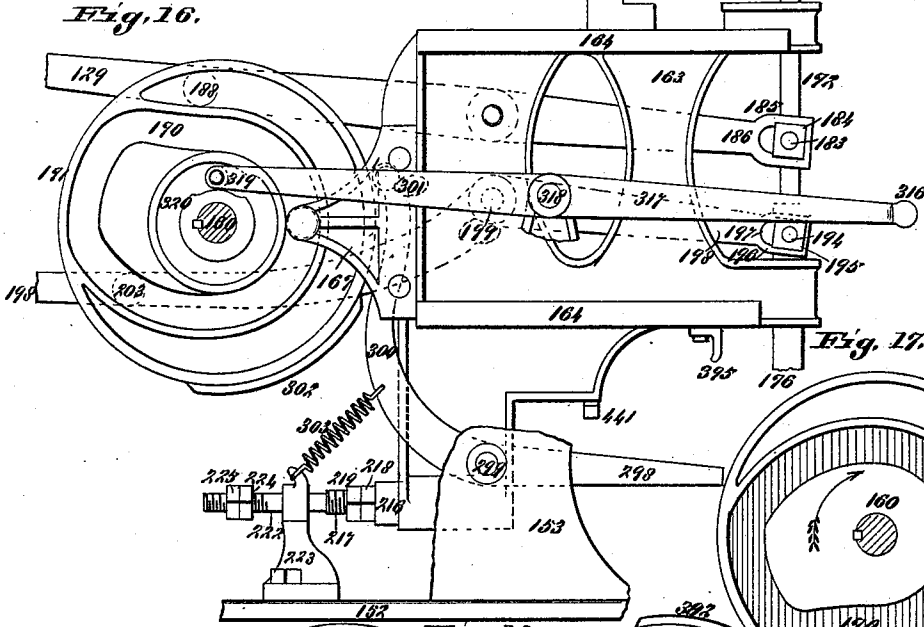
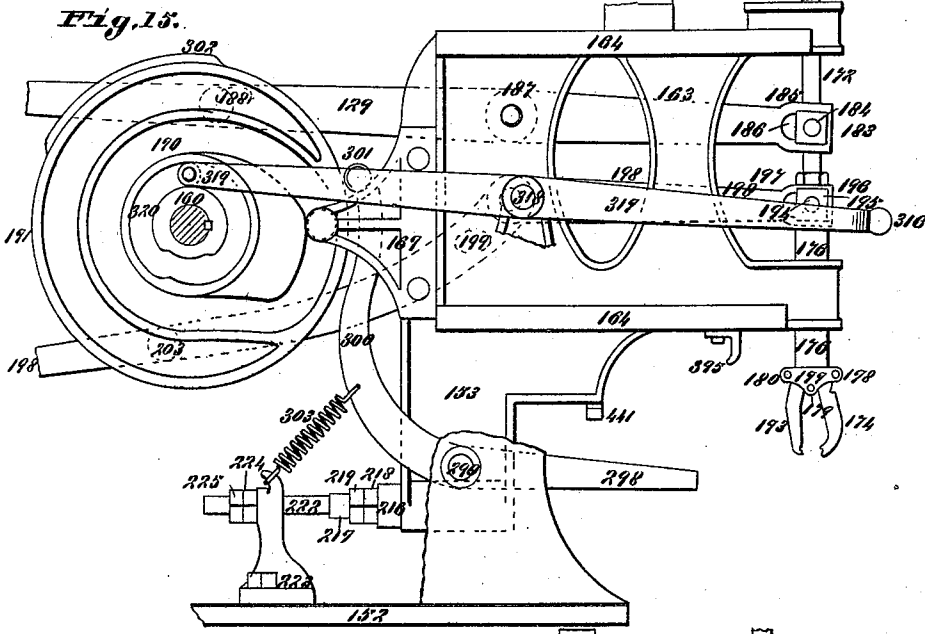

**Fig. 19.** **Fig. 18.**

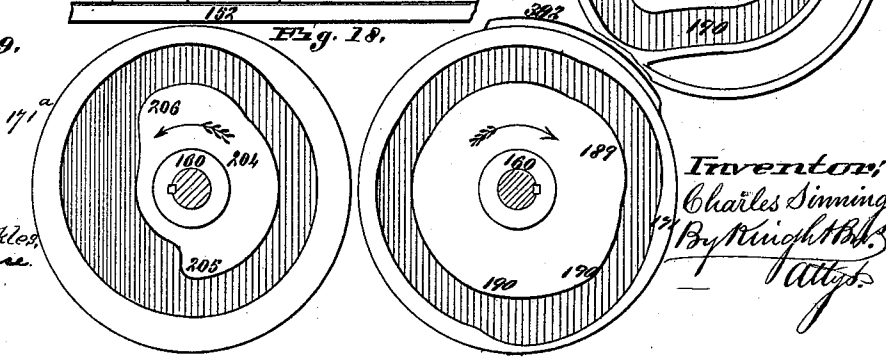

Attest:  
Charles Fickles,  
Geo. & Co.

Inventor:  
Charles Sinning,  
By Knight & Co.  
Atty.

C. SINNING.  
LASTING MACHINE.

No. 456,225.

Patented July 21, 1891.

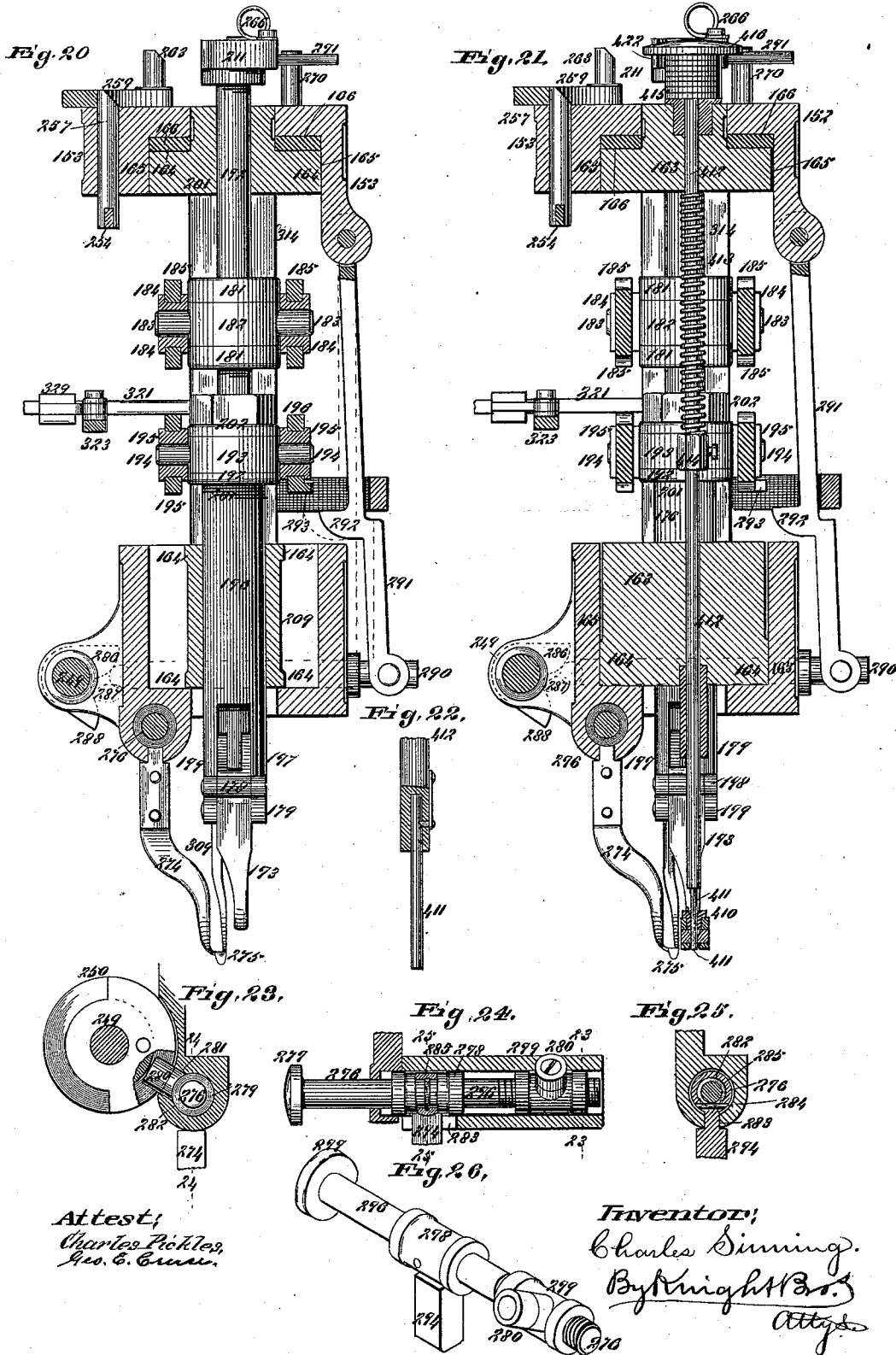

Attest:  
Charles Pickles,  
Geo. E. Cramer.

Inventor:  
Charles Sinning.  
By Knight & Bro.  
Attys.

C. SINNING.  
LASTING MACHINE.

No. 456,225.

Patented July 21, 1891.

Fig. 27.

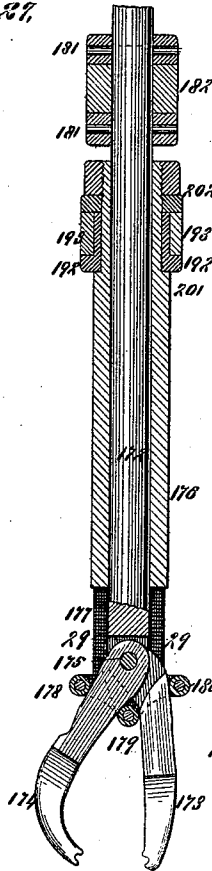

Fig. 28.

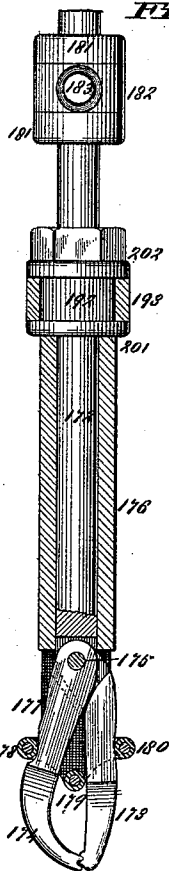

Fig. 33.

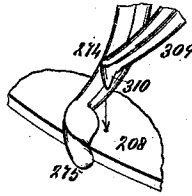

Fig. 34.

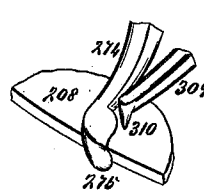

Fig. 35.

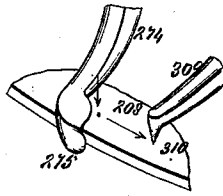

Fig. 36.

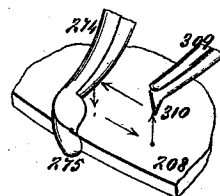

Fig. 29.

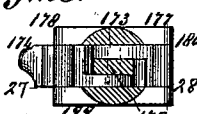

Fig. 30.

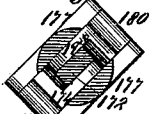

Fig. 31.

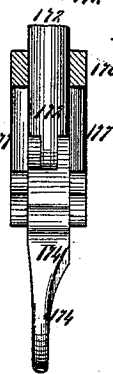

Fig. 32.

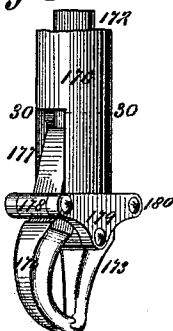

Fig. 37.

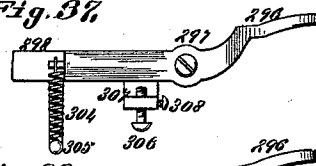

Fig. 38.

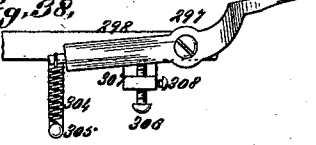
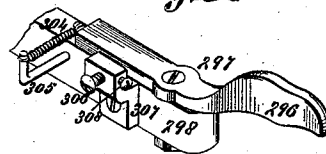

Fig. 39.



Attest,  
Charles Pickles,  
A. C. C. Seal.

Inventor:  
Charles Sinning.  
By Knight Bros.  
Atty.

C. SINNING.  
LASTING MACHINE.

No. 456,225.

Patented July 21, 1891.

Fig. 10.

Fig. 11.

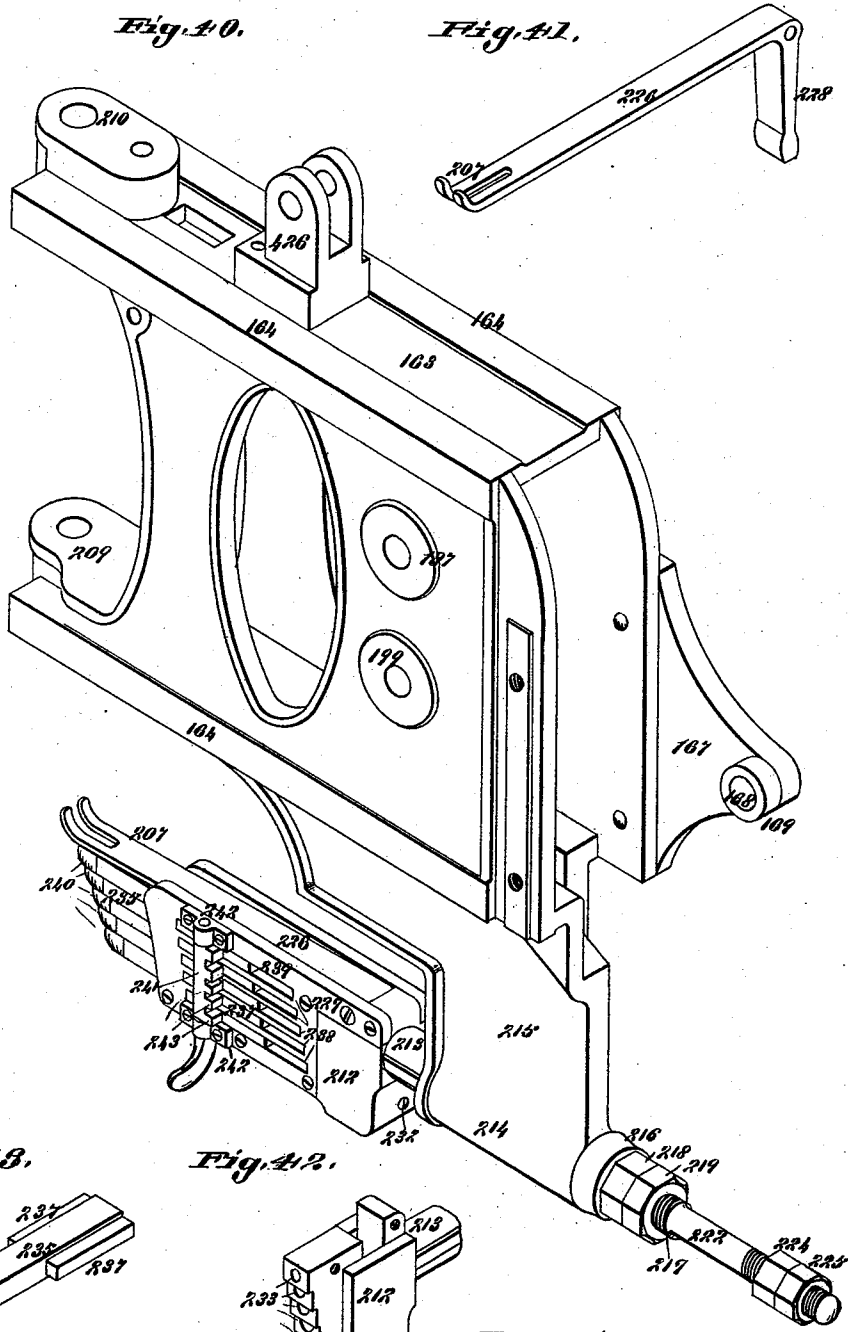

Fig. 13.

Fig. 12.

Attest:  
Charles Pickles,  
Sec. & Comm.

Inventor:  
Charles Sinning,  
By Knight & Co.  
Atty



### C. SINNING. LASTING MACHINE.

No. 456,225.

Patented July 21, 1891.

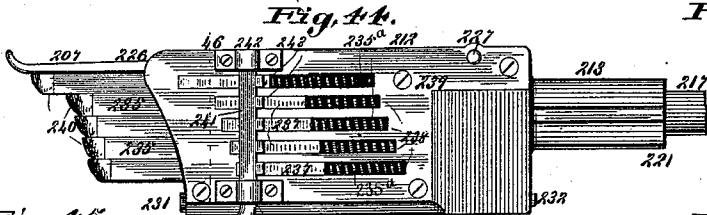

Fig. 46.

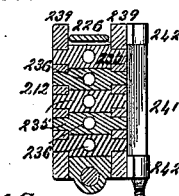

Fig. 45.

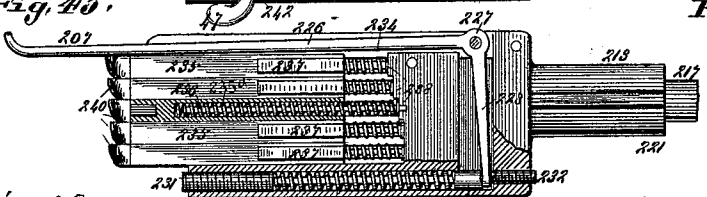

Fig. 47.

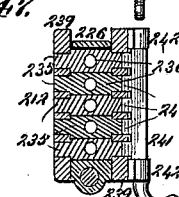

Fig. 48.

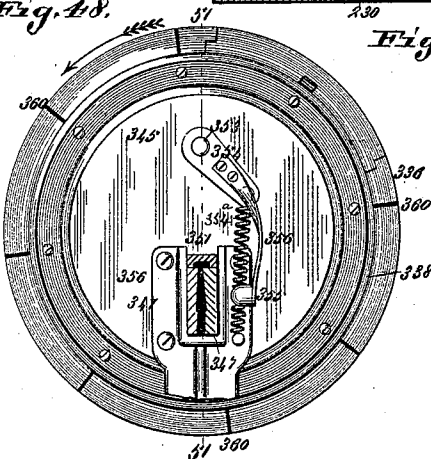

Fig. 49.

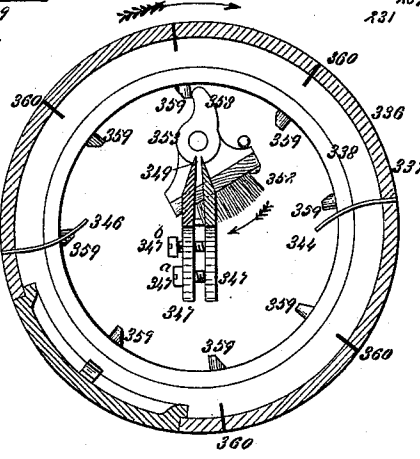

Fig. 50.

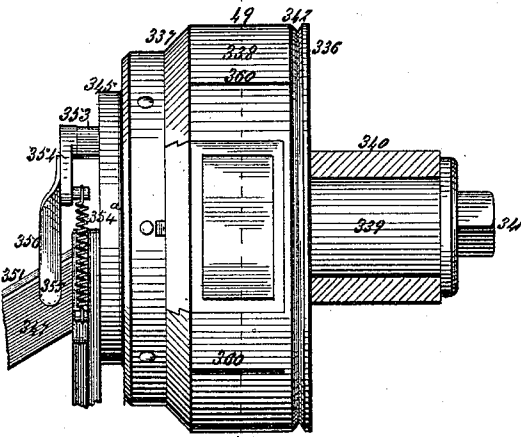
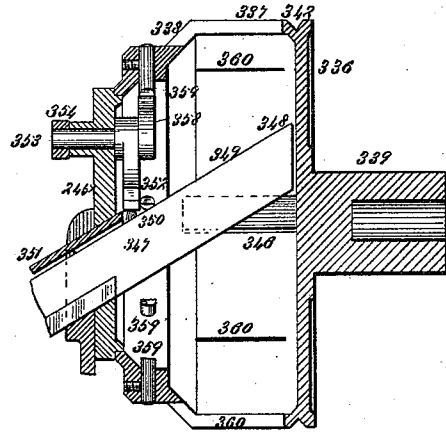
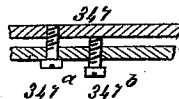

Fig. 51.



Attest:  
Charles Pickles  
Au. & C. Brn.

Fig. 51.<sup>a</sup>



Inventor:  
Charles Sinning  
By Knight & Brn.  
Atty.

# C. SINNING. LASTING MACHINE.

No. 456,225.

Patented July 21, 1891.

Fig. 61

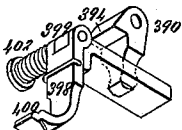

Fig. 60.

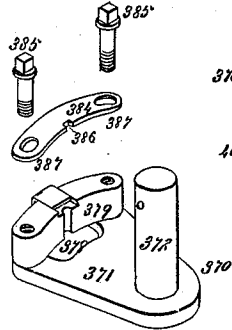

Fig. 52

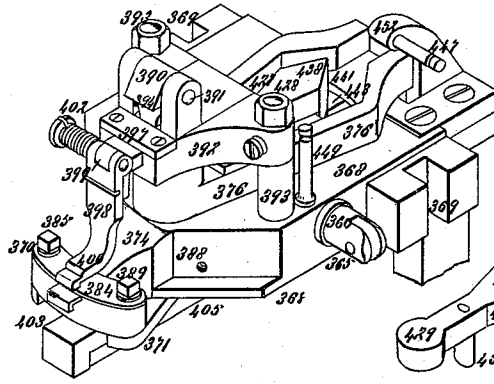

Fig. 54.

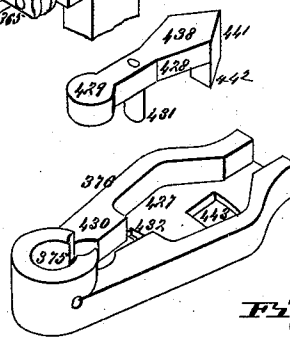

Fig. 53.

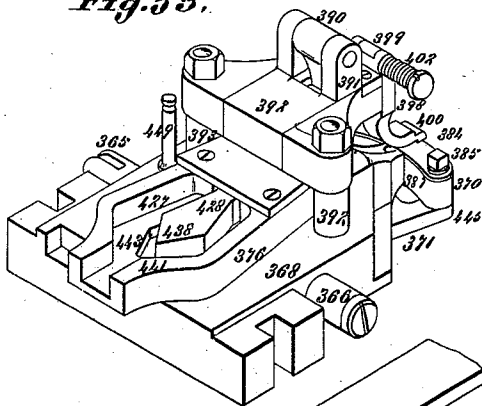

Fig. 55.

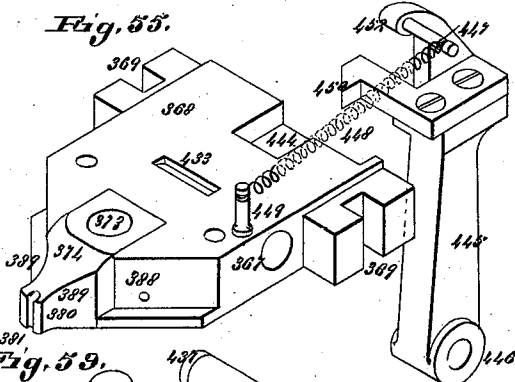

Fig. 56

Fig. 62.

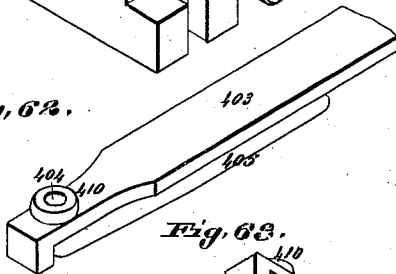

Fig. 63.

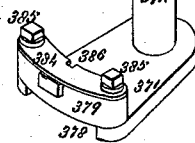

Fig. 58.

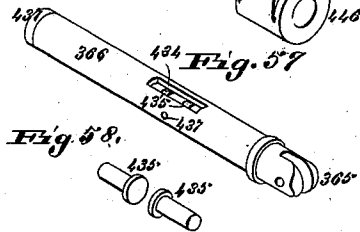

Fig. 57

Fig. 64, Fig. 65

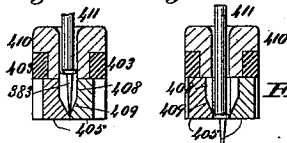
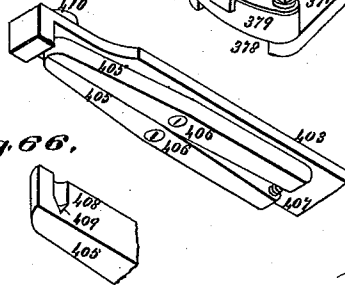

Fig. 66.



Attest:  
Charles Pickles,  
Q. C. C. C. C.

Inventor:  
Charles Sinning,  
By Knight Bros.  
Atty

C. SINNING.  
LASTING MACHINE.

No. 456,225.

Patented July 21, 1891.

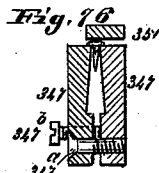
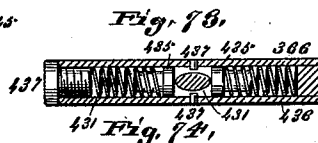
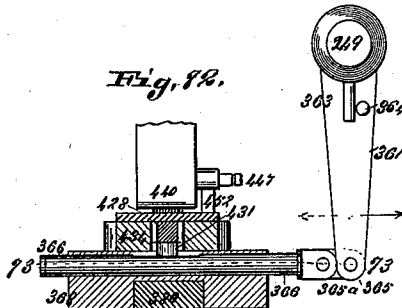
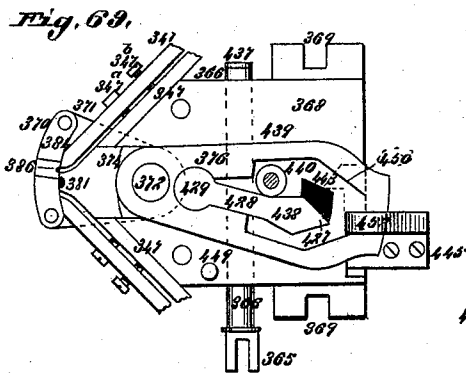
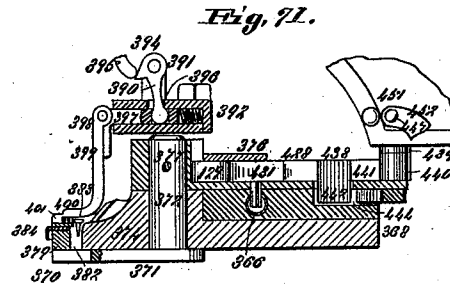
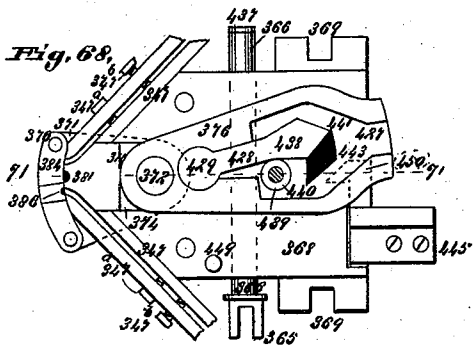
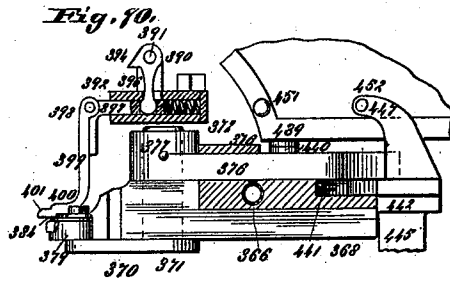
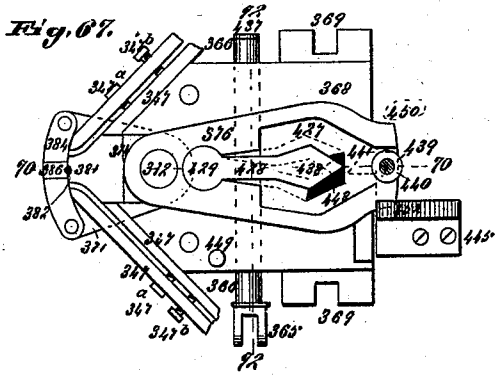

Attest;  
Charles Pichler,  
Geo. S. Ernst.

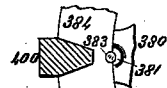
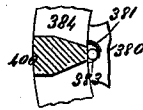

Fig. 75.



Inventor,  
Charles Sinning  
By Knight Bros.  
Atty.

C. SINNING.  
LASTING MACHINE.

No. 456,225.

Patented July 21, 1891.

Fig. 77.

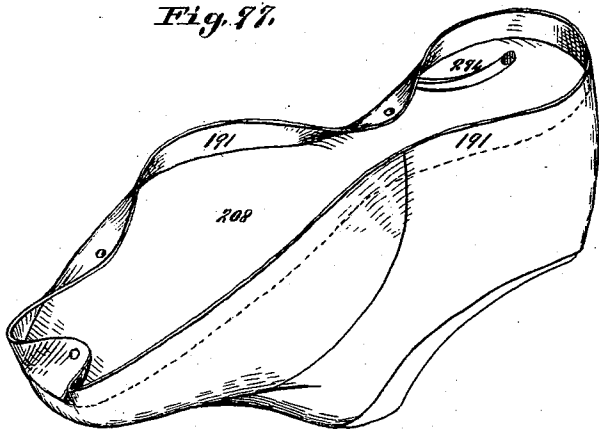

Fig. 78.

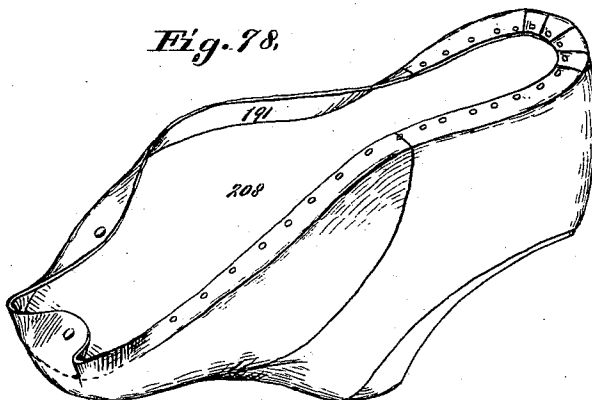

Fig. 79.

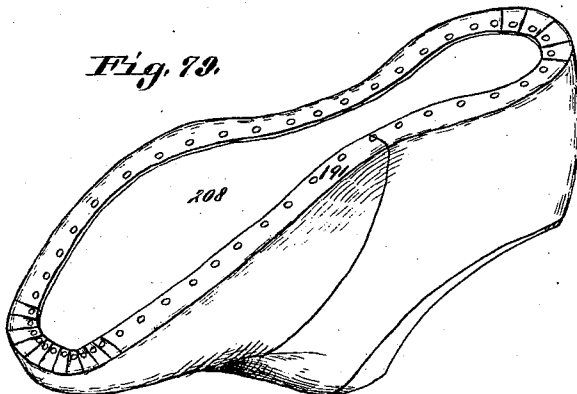

Fig. 80.

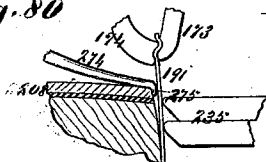
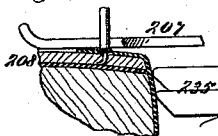

Fig. 81.



Attest:  
Charles Pickles,  
Geo. E. Crane.

Inventor:  
Charles Sinning,  
By Knight Bros.  
Atty.

C. SINNING.  
LASTING MACHINE.

No. 456,225.

Patented July 21, 1891.

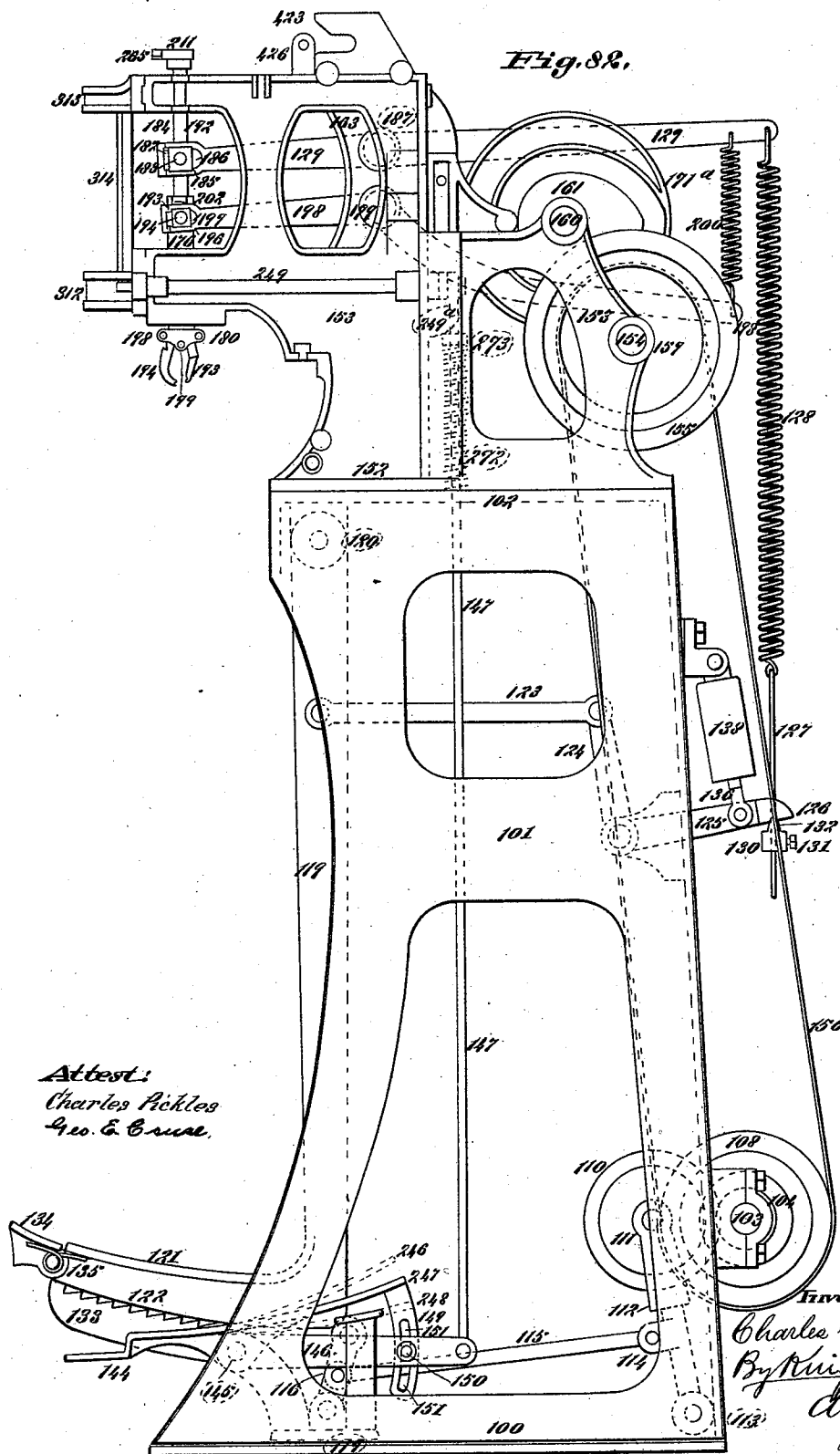

Fig. 82.

Attest:  
Charles Pickles  
Geo. E. Cressel.

Inventor:  
Charles Sinning  
By Knight Bros  
Atty.

C. SINNING.  
LASTING MACHINE.

No. 456,225.

Patented July 21, 1891.

Fig. 84.

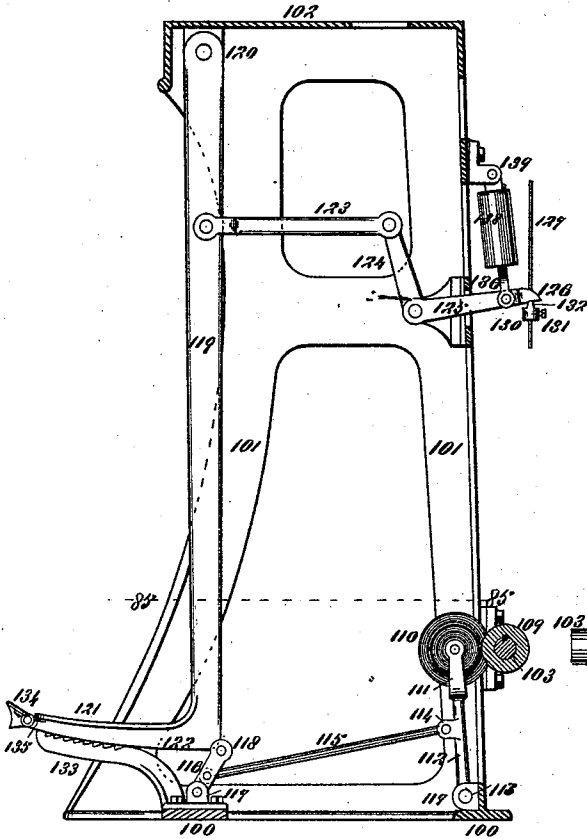

Fig. 85.

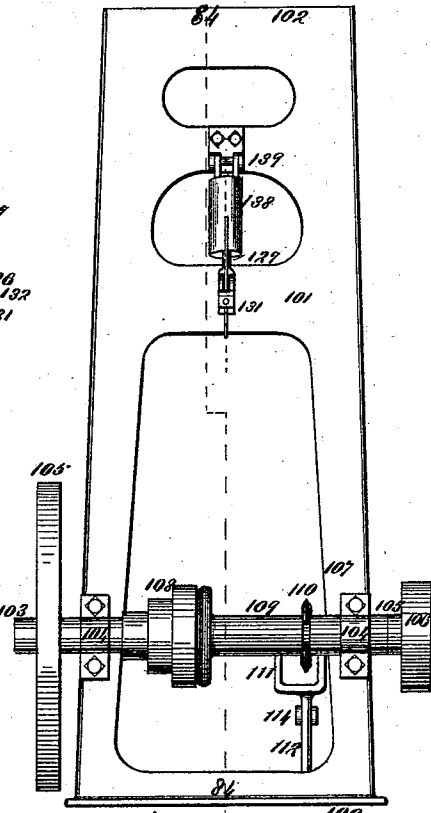

Fig. 86.

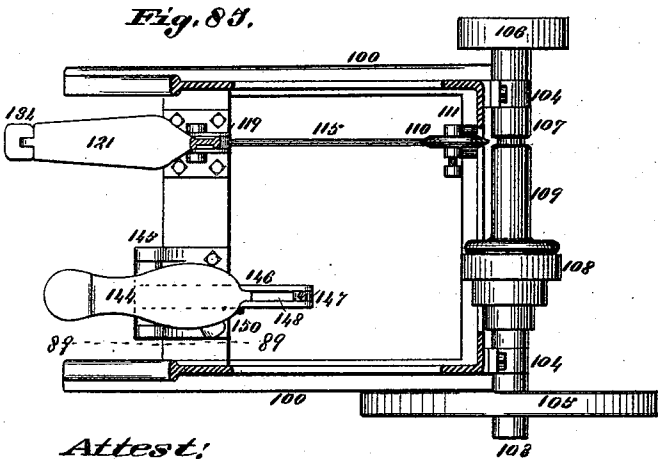

Fig. 88.

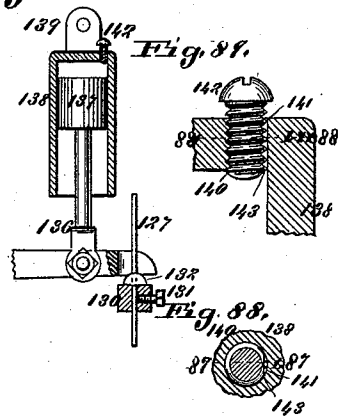
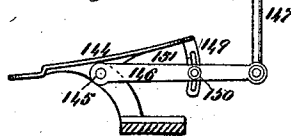

Fig. 89.

Attest:  
Charles Pickles,  
Geo. & Co.

Fig. 89.



Inventor:  
Charles Sinning,  
By Knight Post,  
Atty.

(No Model.)

15 Sheets—Sheet 15.

C. SINNING.  
LASTING MACHINE.

No. 456,225.

Patented July 21, 1891.

*Fig. 90.*

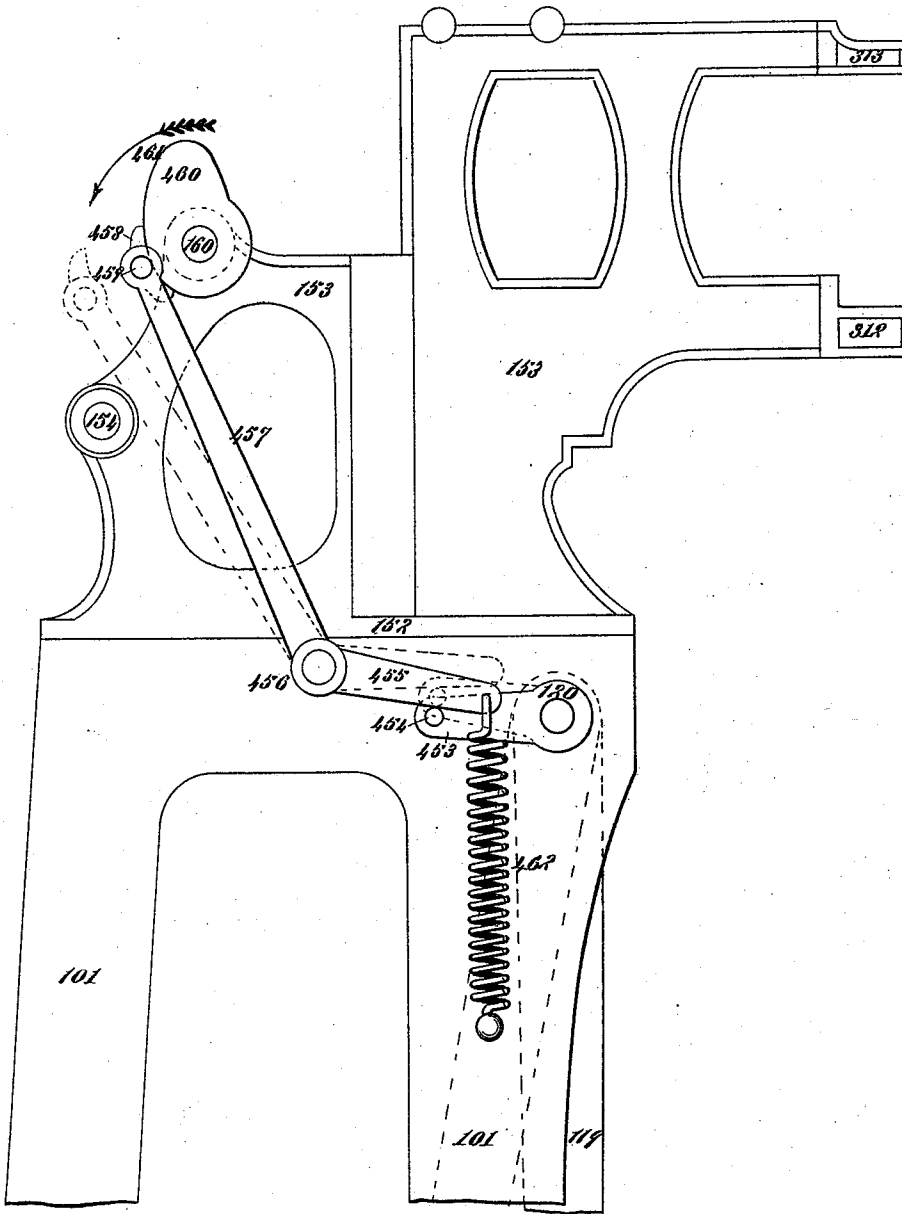

*Attest:*  
Charles Pickles,  
Geo. E. Case,

*Inventor:*  
Charles Sinning,  
By Knight Bro.  
Atty

# UNITED STATES PATENT OFFICE.

CHARLES SINNING, OF ST. LOUIS, MISSOURI.

## LASTING-MACHINE.

SPECIFICATION forming part of Letters Patent No. 456,225, dated July 21, 1891.

Application filed June 4, 1890. Serial No. 354,247. (No model.)

*To all whom it may concern:*

Be it known that I, CHARLES SINNING, of the city of St. Louis, in the State of Missouri, have invented a certain new and useful Improvement in Lasting-Machines, of which the following is a full, clear, and exact description, reference being had to the accompanying drawings, forming part of this specification.

This lasting-machine belongs to that class in which the last is held in the hands of the operator and guided and fed by the machine.

Reference is made to the claims for a statement of the novel features of the invention.

In the drawings, Figure 1 is a front elevation of the head of the machine. Fig. 2 is a rear elevation of the head. Fig. 3 is a side elevation of the head. Fig. 4 is a vertical longitudinal section of the head at 4 4, Fig. 6. Fig. 5 is an elevation of the head from the opposite side to that seen in Fig. 3. Fig. 6 is a plan or top view of the head. Figs. 7 and 8 are detail top views showing the crimper in different positions. Figs. 9 and 10 are detail side elevations showing parts of the crimper mechanism. Fig. 11 is a detail vertical transverse section at 11 11, Fig. 8. Fig. 12 is a top view of the pincher-rod. Fig. 13 is a detail perspective view of the feed-regulator. Fig. 14 is a detail perspective view of the front part of the connecting-rod of the feed mechanism. Figs. 15 and 16 are detail side elevations showing the sliding frame respectively in its forward and backward positions. Fig. 17 is an elevation of the cam for moving the sliding frame. Fig. 18 is a side view of the pincher-lifting cam. Fig. 19 is a side view of the pincher-closing cam. Figs. 20 and 21 are enlarged detail vertical sections of the machine at 20 21, Fig. 5, the carriage or sliding frame being in its rear position in Fig. 20 and forward position in Fig. 21. Fig. 22 is a detail section showing the connection of the tack-driver set to the tack-driver bar. Fig. 23 is a detail transverse vertical section of part of the guide mechanism at 23 23, Fig. 24. Fig. 24 is a vertical longitudinal section at 24 24, Fig. 23. Fig. 25 is a transverse vertical section at 25 25, Fig. 24. Fig. 26 is a perspective view of the guide-bar. Figs. 27 and 28 are vertical sections at 27 28, Fig. 29. Fig. 29 is a horizontal section at 29 29, Fig. 27. Fig. 30 is a horizontal section at 30 30, Fig. 32.

Fig. 31 is an elevation of the pincher-jaws and bearings of same. Fig. 32 is an elevation of the pincher-jaws in closed condition. Figs. 33, 34, 35, and 36 are perspective views showing the guide and feed point in various positions. Figs. 37 and 38 are top views showing the presser-foot in different positions. Fig. 39 is a perspective view of the presser-foot and its bearings. Fig. 40 is a perspective view of the sliding frame. Fig. 41 is a perspective view of the folder. Fig. 42 is a perspective view of part of the pusher-head. Fig. 43 is a perspective view of one of the sliding pusher-bars. Fig. 44 is a side view of the pusher-head. Fig. 45 is a side view of the pusher-head with one side plate removed and with parts in section. Figs. 46 and 47 are transverse sections of the pusher-head at 46 47, Fig. 44. Fig. 48 is a front view of a tack-box with tack-race in transverse section. Fig. 49 is a section of a tack-box at 49 49, Fig. 50. Fig. 50 is a side view of a tack-box. Fig. 51 is an axial section of a tack-box at 51 51, Fig. 48. Fig. 51<sup>a</sup> is a detail section of a tack-race. Fig. 52 is a perspective view of the tack-carrier shown from the front. Fig. 53 is a perspective view of the tack-carrier shown from the rear. Fig. 54 is a perspective view of the tack-switch in two disconnected parts. Fig. 55 is a perspective view of the base-block of the tack-carrier. Fig. 56 is a perspective view of the safety-switch attachment. Fig. 57 is a perspective view of the connecting-rod of the switch. Fig. 58 is a perspective view of the switch-connection-rod pins. Fig. 59 is a detail perspective view of a portion of the tack-carrier, and Fig. 60 is a perspective view of the same in detached parts. Fig. 61 is a detail perspective view of a tack-discharger. Figs. 62 and 63 are perspective views of the tack-deliverer seen, respectively, from the upper and under side. Figs. 64 and 65 are transverse sections of the tack-deliverer at 64 65, Fig. 4, showing the tack-driver and tack in different positions. Fig. 66 is a detail perspective view of the end portion of a tack-deliverer jaw. Figs. 67, 68, and 69 are top views of the tack-carrier and parts of the tack-races with the tack-switch in different positions. Fig. 70 is a vertical longitudinal section at 70 70, Fig. 67. Fig. 71 is a vertical longitudinal section at 71 71, Fig. 68.



Fig. 72 is a transverse vertical section at 72 72, Fig. 67. Fig. 73 is an enlarged detail section of the sliding tubular rod by which the tack-switch is actuated, the section being at 73 73, Fig. 72. Figs. 74 and 75 are detail horizontal sections showing the tack-discharger in different positions. Fig. 76 is a cross-section of a tack-raceway. Fig. 77 is a perspective view of the upper of a shoe upon the last ready for the operation of the machine. Fig. 78 is a perspective view showing the lasting process of the machine partly completed, and Fig. 79 is a perspective view showing the lasting process completed. Fig. 80 is a detail vertical section showing the pinchers drawing up the edge of the leather. Fig. 81 is a detail vertical section showing the tack-driver. Fig. 82 is a side elevation of the machine with most of the details of the head left out. Fig. 83 is a rear elevation of the stand-frame. Fig. 84 is a vertical longitudinal section at 84 84, Fig. 83. Fig. 85 is a horizontal section at 85 85, Fig. 83. Fig. 86 is an enlarged detail vertical longitudinal section at 86 86, Fig. 83. Fig. 87 is an enlarged detail at 87 87, Fig. 88. Fig. 88 is a cross-section at 88 88, Fig. 87. Fig. 89 is a detail vertical longitudinal section at 89 89, Fig. 85. Fig. 90 is a detail side elevation showing the brake.

100 is the base of the machine.

101 is a stand-frame, which may be of any suitable construction and material, and whose top 102 serves to support the head of the machine.

103 is a counter-shaft fitted in bearings 104 on the stand-frame. The shaft 103 carries a balance-wheel 105 and a belt-pulley 106. Upon the shaft is a fixed collar 107, which forms one member of a friction-clutch. 108 is a "cone-pulley" turning loose upon the shaft 103 and restrained from endwise movement on the shaft. The hub 109 of this pulley forms another member of the friction-clutch, the other member being formed by a friction-wheel 110, which is V-formed at the periphery to fit the beveled ends of the collar 107 and the hub 109. The construction is such that when the wheel 110 is moved toward the shaft 103 motion is communicated from the shaft 103 to the pulley 108 by means of the clutch. The wheel 110 has bearing in the forked end 111 of an arm 112, hinged to the frame at 113, so that by a slight swing of the arm on its pivot or hinge 113 the wheel may be moved into or out of contact with the other members 107 and 109 of the clutch. The central part of the arm 112 has ear or ears 114, to which is hinged one end of a connecting-rod 115, whose other end is hinged to the central part of an arm or lever 116, fulcrumed to the frame at its lower end 117 and carrying at its upper end 118 an anti-friction wheel.

119 is a treadle-lever keyed to a fulcrum-shaft 120 near the top of the stand-frame and having at the lower end a forward extension or foot 121, whose lower edge 122 is in the arc of a circle whose center is at the fulcrum-

point 120 of the lever 119. The construction is such that when the lower end of the lever 119 is moved backward from its normal position the edge 122 bears on the anti-friction wheel at 118 and forces the lever 116 backward, so that the clutch-wheel 110 is pushed against the other members of the clutch and the cone-pulley and shaft 103 caused to rotate. The lever 119 may now be swung farther back without changing its bearing upon the anti-friction wheel at 118, so that the machine will continue running in all positions of the lever 119 except its normal position. (Shown in Figs. 82 and 84.) The lever 119 is also used to regulate the power of the spring by which the crimping-pinchers are drawn upward, and the operation of the lever for this purpose will now be described.

123 is a connecting-rod, one end of which is hinged to the lever 119 and the other end hinged to the vertical arm 124 of a bell-crank lever, whose horizontal arm 125 is forked at the end 126. Through the fork extends from above the rod 127 of the lifting-spring 128, whose upper end is connected to the rear end of the lever 129, by which the crimping-pinchers are drawn up.

130 is a collar upon the rod 127, held in place by a set-screw 131 and having at top ribs 132, which occupy notches in the under side of the fork 126, the construction being such that as the lever 119 is moved backward the forked end 126 is depressed and increases the tension of the spring 128.

133 is a ratchet-bar immediately below the edge 122, and 134 is a pawl hinged to the treadle-foot 121 and adapted to engage the ratchet-bar 133 and hold the lever 119 from forward movement. To engage the pawl with the ratchet, the pawl is depressed by the foot of the operator, and when engaged with the ratchet is held in engagement by friction. On a slight backward movement being given to the lever 119 the pawl is thrown up by a spring 135 beneath it, and then the lever may be swung forward by the spring 128.

In order to check the rapid movement of the lever I connect with it a dash-pot, which will be now described. The horizontal arm 125 of the bell-crank is hinged to the rod 136 of a piston 137, the piston working in an open-bottomed cylinder 138, hinged at 139 to the stand-frame. The cylinder has at its upper end a small vent-hole 140, that is screw-threaded, and a channel 141 is cut through the thread at one side. 142 is a screw fitting in the hole 140 and made flat at one side, as seen at 143. The construction is such that when the flat part 143 of the screw exactly coincides with the channel the air passes freely through the channel, and by turning the screw the channel may be partly or wholly closed.

144 is the foot of the treadle by which the crimping movements are governed and also the position of the last. The treadle-foot rocks on a pin 145, which also forms the pivot of a treadle-arm 146, to whose free end the

treadle-rod 147 is hinged. The arm 146 has a vertical longitudinal slot 148, through which passes a downward extension 149 at the rear part of the treadle-foot, and is held by a screw-bolt 150, that passes through the arm and through a slot 151 in the extension 149.

The head of the machine has a base 152, which is secured to the top of the stand-frame, and an upright frame 153. The frame 153 may be attached directly to the top of the stand without the intervention of the base 152. The frame 153 is of any suitable construction to give bearing to the moving parts, and may be made partly or wholly integral with the base 152.

154 is a shaft carrying a cone-pulley 155, connected by a belt 156 with the cone-pulley 108 on shaft 103. The shaft 154 has bearings at 157.

158 is a spur-pinion upon the shaft 154. The spur-pinion 158 engages a spur-wheel 159 upon the cam-shaft 160. The shaft 160 has bearings at 161 in the fixed frame 153. The shaft 160 carries a balance-wheel 162, which is adapted to be used as a hand-wheel in adjusting the mechanism to any desired position when it is not running.

163 is a longitudinally-sliding frame or carriage having faces 164, bearing against parts 165 of the fixed frame, and bearing-strips 166, which are inserted over the carriage. (See Figs. 2, 4, and 40.)

167 are extensions from the rear part of the carriage, which have inwardly-projecting studs 168, carrying anti-friction rollers 169, that work in the cam-channels 170 of the cams 171 and 171<sup>a</sup> upon the shaft 160. These cams rotate in the direction indicated by the arrow and cause the longitudinal reciprocation of the carriage.

The pinchers, with their rod or stem, are shown in detail in Figs. 27 to 32, inclusive.

172 is the pincher rod or stem, to which the jaws 173 and 174 are pivoted at 175. The rod 172 carries a sleeve 176, which has endwise movement on the rod. The sleeve has extensions 177 lying each side of the jaws and connected by three cross-pins 178, 179, and 180, carrying anti-friction rollers. The construction of the parts is such that when the sleeve 176 moves downward on the rod 172 the pins 178 and 180, by pressure against the outer sides of the jaws, press their points together to hold the edge of the leather while the pinchers are raised to draw up the leather on the last. To release the leather the sleeve is drawn upward on the rod, when the points of the jaws 173 and 174 are separated by the upward movement of the sleeve on the rod, which relieves the jaws from the pressure of the pins 178 and 180, and the jaws are opened by the pressure of the pin 179 against their inner sides. The jaws are shown in their open and closed positions in Figs. 27 and 28, respectively. The points of the jaws are serrated to give them a firm hold of the leather.

I will now describe the means for giving

the described vertical movements to the rod 172 and sleeve 176. The rod has two fixed collars 181, between which is a loose ring 182, having at opposite sides transversely-projecting studs 183, which have bearing in blocks 184. These blocks have bearing in slots 186 in the forked end 185 of the lever 129, the blocks having slight endwise movement in the slots, as the rod has rectilinear movement, and the end of the lever moves in an arc of a circle. The lever 129 is fulcrumed in the carriage at 187. The upward movement of the forward end of the lever 129 and the pinchers in drawing up the leather is caused by the spring 128, while the downward movement of the pinchers is caused by the cam 171, the lever having a cam-stud 188, armed with an anti-friction roller, which plays in the cam-channel 189. In order to allow the spring to act to draw up the pinchers, there is a recess 190 at the side of the channel 189, into which the cam-stud enters. (See Fig. 18.) The jaws of the pinchers are open when they descend, the edge 191 of the leather being between them, and immediately after reaching their lower position the sleeve 176 descends and closes them upon the leather. The sleeve 176 carries a fixed collar 192, having a circumferential channel containing a ring 193, with studs 194, working in blocks 195, that have endwise movement in slots 197 in the forked end 196 of the lever 198. This lever is fulcrumed to the carriage at 199, and its rear end is connected to the lever 129 by a spiral spring 200. The spring acts to depress the sleeve 176 whenever the sleeve is not lifted by either its special cam 204 or by the pincher-rod. The collar 192 bears at bottom upon a shoulder 201 of the sleeve and is held at top by a nut and washer 202. (See Fig. 27.) The lever 198 has a cam-stud 203, carrying an anti-friction roller, which bears against the cam 204 of the cam-wheel 171<sup>a</sup>. The cam has a part between the salient points 205 and 206 which allows the ascent of the stud 203, under the influence of the spring 200, to carry down the sleeve and close the jaws, as before set forth. When the jaws close upon the leather, the rod 172 is drawn up by spring 128 and lifts the sleeve 176 with it until the jaws have reached their highest point, when the stud 188 reaches the end of the channel enlargement 190, and the rod 172 is held rigid. At the same time the projecting part 206 of the cam 204 reaches the stud 203 and lifts the sleeve, opening the jaws and releasing the leather 191. After the jaws are opened the rod and sleeve again extend together in the same relative position until the jaws reach their lowest point, when the sleeve again descends on the rod and closes the jaws, as before described. As the pinchers are ascending the carriage is at rest; but as they reach their upper position and before they open the carriage begins a forward movement, so that the leather 191 is not simply drawn upward, but also drawn forward over the last, while at the same time the

folder 207 begins to move forward and folds the edge of the leather down on the insole 208, the pinchers opening while the folder is moving forward. At the same time the spring 5 pusher-feet are pressed against the leather and insure its smooth folding against the side of the last. The jaws open while the folder is moving forward, and the folder continues its forward movement and folds down the 10 edge of the leather. The carriage continues to move forward, and the tack is driven through the leather and insole. The sleeve 176 has bearing in the forward extension 209 of the carriage, and the rod or spindle 172 has 15 bearing in the sleeve and above the sleeve in the extension 210 of the carriage. The top of the rod 172 carries a head 211, by which the rod is turned, when required, for the crimping of the leather.

20 The folding and pressing devices are upon a single head 212, supported on a rod 213, which has bearing in a longitudinal socket 214 in a downward extension 215 of the carriage. The rear end 216 of the socket is 25 closed except for a hole of smaller diameter than the socket, through which passes a reduced part 217 of the rod. This reduced part 217 is screw-threaded and carries a stop-nut 218 and a lock-nut 219, the former of which 30 limits the forward movement of the rod in the socket.

220 is a spiral spring surrounding the part 217 within the socket, and whose rear end bears against the rear end 216 of the socket, 35 while the front end bears against the shoulder 221 of the rod. The spring acts to push the head 212 forward. At the rear of the reduced part 217 is a still further reduced part 222, that passes through a post 223, fixed to the 40 base 152. Behind the post 223 the rod is screw-threaded and carries a stop-nut 224 and a lock-nut 225, the former limiting the forward movement of the head 212 relatively to 45 the fixed frame, so that it does not accompany the carriage in its extreme forward movement.

The folder 207 constitutes the front end of the horizontal arm of a bell-crank 226, which is fulcrumed to the pusher-head at 227. The 50 vertical arm 228 of the bell-crank rests at its front side against a sliding block 229, bearing against the rear end of a spiral spring 230, whose front end rests against an adjusting-screw 231, by which the power of the spring 55 may be governed.

232 is a screw whose front end rests against the rear side of the vertical arm 228 to limit the descent of the folder. Thus the folder is 60 pressed down on the fold 191 of leather by the spring 230, and the amount of pressure regulated by the screw 231. The head 212 has a number of holes 233 to receive fixed pins 234, which are surrounded by spiral springs 235<sup>a</sup>. The presser-bars 235 are in a vertical 65 series and are made rectangular in transverse section, so as to fit snugly together. The presser-bars have sockets 236 to receive the

front ends of the pins 234 and the spiral springs surrounding the pins. The fore ends 70 of the spiral springs rest against the inner ends of the sockets 236 and their rear ends against the head 212. The presser-bars have side wings 237, which work in slots 238 of the 75 removable side plates 239 of the head. The bars 235 end in pads 240, which bear against the leather and push it against the side of the last. In order to hold the bars in their retracted position, (which is sometimes required 80 in examining or testing parts of the machine,) I provide a catch 241, which turns one-fourth around in bearings 242, and which has a number of teeth, 243, adapted to enter the slots 238 and engage the fore ends of the wings. Ordinarily the catch 241 is in the position seen in 85 Fig. 44 and does not interfere with the end-wise movement of the bars. The lower part of the head has a fixed extension 244, which is bored through at 245, the bore extending through the body of the head and receiving the screws 231 232, the block 229, and the 90 spring 230. The retracted position of the pusher-bars, with the catch in holding position, is shown in Figs. 45 and 47.

The means for regulating the feed and for 95 crimping the leather 191 at the toe of the shoe will now be described. The treadle 144 has an upper position at the toe, as shown by dotted lines at 246, Fig. 82, a middle position, (shown in full lines at 247 in the same figure,) 100 and a lower position, (shown by dotted lines at 248 in the same figure.) The crimping takes place only when the treadle is in the lower position, and this is done by turning the pinchers while they hold the leather. The treadle-rod 147 is connected at the upper end to a 105 crank-arm 249<sup>a</sup> upon a rock-shaft 249, having upon it a worm-cam 250. One end of this cam has a wrist-pin 251, that occupies a slot 252 in the lower end of a connecting-rod 253, connected at the upper end to a lever 254, 110 working on a fulcrum 255 upon the fixed frame 153. The lever 254 is held in its normal and horizontal position (seen in Fig. 3) by a spring 256, extending from its free end to the fixed frame. To the other end of the 115 lever 254 is pivoted a pin 257, that works in a vertical socket 258. The top of the pin extends above the top of the frame.

259 is an arm pivoted to the frame at 260, so as to swing in a horizontal plane, and drawn 120 toward the head 211 of the pincher-rod by a spring 262, connected to the arm and to a pin 261 on the fixed frame. This arm carries at the free end a standing bevel-ended pin 263, which, as the lever swings to the head 261, 125 passes beneath the inclined part or tooth 264 of a spring-latch 265. The latch is pivoted to the head at 266 and is depressed by a spring 267.

268 is a standing stud upon the top of the 130 carriage, having on it an anti-friction roller 269. The construction is such that the stud 268, on the forward movement of the carriage, pushes the arm to its outer position,

if the arm is not already in that position. The outer position of the arm is shown in Fig. 6 and by broken lines in Fig. 8. When the side and heel of the shoe are being worked upon, the arm 259 is held in its outer position by the pin 257, against which the inner side of the arm bears. When the toe of the last comes to the position to be operated upon, the treadle 144 is depressed to the lower position at the inner end, which pulls down the pin 257 and releases the arm, so that it is drawn inward by the spring 262, and the pin 263 is carried beneath the tooth 264. On the forward movement of the carriage the arm is forced outward by the stud 268 and carries the head of the pincher-rod into the position seen in Fig. 8, when the pin escapes from the tooth and the arm is carried to its outer position. On the return movement of the carriage a standing stud 270 on the fixed frame engages a radial pin 271 upon the head and restores the pinchers to their normal position. In case the pin 257 is in its depressed position when the arm 259 reaches its outer position, the arm swings inward as soon as the carriage moves backward, and the stud 268 permits such inward movement of the arm, and the pin 263 again engages the tooth 264. In case the toe of the shoe has been finished the treadle 144 is raised into the upper position at the toe and the pin 257 moves upward into the course of the arm 259, which passes over the top of the pin in its outward movement, depressing the pin in its passage, and the pin after depression is thrown up by the spring 256 and engages against the inner side of the arm, as before explained.

To enable the forcing down of the pin 263, it is beveled at top, the arm striking the lower part of the bevel. An equivalent construction would be to bevel the part of the arm which strikes the pin.

At 272, Fig. 82, is shown by dotted lines a spiral spring engaging a collar 273 on the rod 147 so as to lift the rod and throw the treadle 144, into the position shown at 246, which causes the parts to take position for lasting the side of the shoe.

274 is the guide for the work, said guide extending beneath the fold 191 of the leather and lying on the insole, with a small downturned lip 275 engaging over the edge of the insole.

Now in lasting the toe and the heel it is necessary that the last should be in a position nearer to the body of the machine than in lasting the sides, being nearest when lasting the toe. The means for automatically changing the position of the guide for this purpose will now be described. 276 is a screw-rod turned by a head 277 and carrying a collar 278 and a nut 279. The nut has a stud 280, carrying a friction-roller, which engages in the worm of the cam 250, so that as the cam is turned the screw-rod is moved endwise in its socket 282, which is made longitudinally in the fixed frame 153. The stud

280 projects through a longitudinal slot 281 in the side of the socket 282 and engages the worm of the cam 250, as already stated. The guide 274 is rigidly attached to the collar 278 and extends downward through a longitudinal slot 283. The screw-rod turns freely in the collar 278, but is restricted from endwise movement therein by a tangential pin 284, which passes through the collar and engages in a circumferential groove 285 of the screw-rod. The guide 274 is adjusted as to its mean position (to and from the body of the machine) by the turning of the screw 276 in the collar or nut 273, while the described inward and outward movement of the guide as the work progresses is caused by the worm-cam 250. In Figs. 9 and 82 the treadle 144 and worm-cam 250 are shown in the intermediate position, or position for lasting the heel, the guide 274 being also in the intermediate position. If now the treadle 144 be moved into the position indicated by broken lines at 248, the worm-cam will take the position shown in Fig. 10, and the guide 274 will be then in the inner position, as required in lasting the toe. If, however, the treadle 144 is moved or allowed to move into the position indicated by broken lines 246, Fig. 82, the worm-cam will be turned in the opposite direction to that indicated by the arrow in Fig. 9, and no motion will be given to the rod 253, as the wrist-pin 251 will only move the length of the slot 252. The guide 274 will, however, be moved outward by the rotary motion of the worm-cam 250 and take the position required in lasting the sides of the shoe.

The pinchers do not act while lasting the heel, and the device for throwing them out of action will now be described. The rock-shaft 249 carries at its fore end a cam having projections 286 and 288 and a depression 287 between them. When the side of the shoe is being lasted, the position of the cam is as seen in Figs. 20 and 21, the upper projection 286 being in action. The position of the cam when lasting the heel is seen in Fig. 1, while the lower projection 288 is in action in lasting the toe. The cam acts against an anti-friction roller 289 at the end of a sliding rod 290 transverse to the machine and connected at the opposite end to a hanging arm 291, having a catch 292, which is inclined at the lower side and horizontal at the upper side to engage a projection 293 on the lever 198, so that when the roller 289 is in the depression 287 the catch 292 is in position to arrest the descent of the lever, and consequently of the sleeve 176, so that the pinchers do not close. When, however, either of the projections 286 or 288 is acting on the roller 289, the catch 292 is held out of the course of the projection 293, and the pinchers close upon the leather 191 at each descent. The inner position of the arm is shown by the broken lines in Fig. 20. 294 is a draw-spring tending to draw it into this position, and doing so whenever it is not held in its inactive position

by one of the cam projections 286 or 288, the ends of the spring being connected, respectively, to the fixed frame and to a stud 295 upon the rod 290.

5 The presser-foot is shown in detached views in Figs. 37 and 39. It has motion in a vertical plane, descending by a positive movement upon that part of the leather which has just been made fast to the insole and preventing  
10 its being torn up by the pinchers. 296 is the presser-foot, connected by a vertical screw-pivot 297 with the horizontal arm 298 of a bell-crank lever which is fulcrumed to the fixed frame at 299. The upright arm 300 of  
15 the bell-crank carries an anti-friction wheel 301, which is acted on by the peripheral cam projection 302 of the cam-wheel 171 to force down the presser-foot. The presser-foot is raised by a draw-spring 303, by which the upright arm of the bell-crank is connected to  
20 the post 223. The presser-foot is adjustable on the screw-pivot 297 being drawn in one direction by a draw-spring 304, by which its tail end is connected to the pin 305, the spring  
25 holding the tail end against the point of a screw 306, turning in a bracket 307 and held in place by a set-screw 308. The presser-foot works in very near proximity to the folder.

30 The means for feeding forward the last to the machine will now be described. The feed-finger 309 (like the guide) is curved around, so as to engage the insole beneath the edge  
35 191 of the leather. It has a point 310 at bottom, which engages the insole on the descent of the finger, after which the point moves forward horizontally and then rises, at first vertically and then in an inclined upward direction,  
40 to a point from which it descends vertically to the insole. The several positions are shown in Figs. 33 to 36. The feed-finger is attached to the spindle 311, having bearings at 312 313 in the face-plate 314 of the fixed frame.

45 315 are collars fixed on the spindle, and between them are the rounded ends 316 of the forked end of the lever 317, by which the spindle has vertical movement. This lever is fulcrumed to the fixed frame at 318 and  
50 carries at the rear end a cam-stud 319, armed with an anti-friction roller which plays in a cam-channel 320 of the cam-wheel 171.

321 is a horizontal arm fixed to the spindle 311 and passing through a mortise 322 at the  
55 fore end of an arm 323. The arm 323 is hinged at the rear end to a sliding bar 324, which works endwise in a bearing 325 of the fixed frame. The bar is actuated by the cam-wheel 171<sup>a</sup> through a stud 326 on the bar,  
60 which works in a cam channel or groove 327 of the cam-wheel. By means of the cam-wheel 171<sup>a</sup> the feed-spindle is given rotary oscillation.

65 328 is a torsion-spring surrounding the spindle and having the upper end connected with the upper bearing of the spindle, while its lower end bears against the rear side of the

arm 321. The construction is such that the spring acts to throw the arm 321 outward. The inward movement of the arm 321 is limited by a screw 321<sup>a</sup>, which screws in an arm 321<sup>b</sup>, extending horizontally from the spindle, the point of the screw impinging against the frame when the arm 321 reaches its outer position. The feeder should work as near as  
75 possible to the guide 274, and the screw 321<sup>a</sup> gives means for adjustment in this respect. The degree of feed movement is greatest when lasting the side of the shoe and least when lasting the toe, while in lasting the heel the  
80 feed movement is intermediate.

The means for automatically changing the degree of the feed will now be described. To increase or diminish the amplitude of oscillation in the arm 321 and spindle 311, the slotted end or yoke 329 of the arm 323 is moved  
85 endwise of the arm 321. For this purpose the cam-shaft 249 has an arm 330, which carries a pin 331, engaging in an elongated bearing of a hanging arm 332, hinged to the fixed  
90 frame at 333. The hanging arm is slotted at 334 for the passage of the arm 323, so that the position of the yoke 329 upon the arm 321. When the shaft 249 occupies the position for lasting  
95 the sides of the shoe, the yoke 329 is at its farthest point from the free end of the arm 321, and consequently the arm has the greatest amplitude of movement. By turning the shaft 249 into the position for the  
100 lasting of the heel the yoke 329 is moved to a central position upon the arm 321, while when lasting the toe the yoke is moved to the end of the arm 321. To still further lessen the amount of feed, a recess 335 is made in  
105 the outer side of the arm, so that there is some lost motion of the arm in the mortise 322, it being understood that the feed takes place when the arm 321 moves backward.

The machine has two rotary tack-boxes 336  
110 and 336<sup>a</sup>, the former containing shorter tacks than the latter, the shorter tacks being for the sides of the shoe and the longer tacks for the toe and heel.

There are automatic devices by which the  
115 proper tacks are furnished during the continued operation of lasting the shoe all around. A description of one of the tack-boxes will apply equally to the other. Especial reference is made to Figs. 48, 49, 50, and  
120 51 for the details of construction, the position of the tack-boxes in the machine being clearly seen in Figs. 1 and 6. The box has a cylindrical part 337 and a frusto-conical part 338, which may be made integral with the gudgeon  
125 339. The gudgeon turns in a bearing 340, being held therein by a screw 341. The part 337 is circumferentially grooved at 342 for a belt 343, which passes around a grooved pulley 344 on the cam-shaft 160. 345 is a fixed  
130 head having a peripheral recess in which fits the edge of the part 338, the head closing the front end of the box and giving bearing to the tack-race and other things, as will be herein-

after set forth, and forming a front bearing on which the box turns. The part 337 has one or more interior ribs or ledges 346, adapted to lift the tacks and drop them upon the inclined tack-race. The tack-race consists of two parallel bars 347, inclined downward from their ends 348 within the tack-boxes to the place of delivery outside. The distance asunder of the bars is such that the shank of the tacks will fall between the bars, while the head rests on the top of the bars. The upper edges 349 of the bars are beveled upon the outside, so that they come to an edge and give no place on which the tacks can readily lodge. Each tack as it falls in position slips down the race through the aperture 350 in the fixed head. 351 is a plate whose lower side is parallel with the upper edge of the tack-race and such a distance therefrom as to be just out of contact with the heads of the tacks. The two bars 347 are secured together by screws 347<sup>a</sup> and are kept asunder by distance-screws 347<sup>b</sup>, the screws 347<sup>a</sup> turning freely in one bar and screwing in the other bar, while the screws 347<sup>b</sup> screw in one bar and their points bear against the inner side of the other bar. 352 is a brush attached to a shaft 353, turning in the head 345, the brush oscillating transversely with the race and brushing therefrom any tacks that may not be in proper position. The shaft 353 extends through the head 345 and carries outside the head an arm 354. The arm 354 carries a hammer 355 on a flexible stem 356, the construction being such that as the arm 354 oscillates the hammer taps the tack-race and prevents the clogging of the tacks in the race. The discharging ends 345 of the rotary tack-boxes both face inward. The driving-belt 343 of the box 336 is straight, while the belt of the box 336<sup>a</sup> is crossed. The belts run over idler-pulleys 357. In order to oscillate the shaft 153, the shaft carries a tappet-arm 358, against which impinge the tappets 359, projecting from the inside of the part 338 of the box, the rotation of the box bringing them in contact with the arm 358. 354<sup>a</sup> is a draw-spring connecting the free end of the arm 354 with the head 345 and tending to restore the arm to the normal position as the arm 358 escapes from the tappets 359 and carrying the hammer 355 against the tack-race. Both of the tack-races are kept charged with tacks, so that tacks may be used from either of them. The tack-boxes have narrow slots 360 for the escape of headless tacks and other useless matter.

The tack-switching mechanism will be now described. The longer tacks are used for the heel and the toe, and the shorter tacks for the sides of the shoe. It has already been said that the action of the guiding, feeding, and the drawing and crimping parts is modified automatically relatively to each other by means of the treadle 144. The tack-switching mechanism is also governed by the movement of this treadle and associated mechanism simultaneously with the other parts. The

shaft 149 has upon it an arm 361, loose on the shaft. The arm is carried to the left of a person facing the machine by a spring 362 and is swung in the other direction by the pressure of a radial pin 363 of the shaft against a pin 364 upon the arm. (See Figs. 1 and 72.) It has been said that the spring carries the parts into position for lasting the sides of the shoe whenever the foot is removed from the treadle 144, and at this time the tack-race of the box 336 is furnishing the shorter tacks for use, the pin 363 having pushed the arm 361 to the right. For details of the parts of the tack-switch now to be described reference is made to Figs. 52 to 76, inclusive. The free end of the arm 361 is hinged at 365 to a tubular bar 366, sliding in a socket 367 of the base-block 368 of the tack-switch. This block 368 is rigidly attached to the fixed frame 163 by bolts passing through the recesses 369. The tack-carrier 370 has a bottom plate 371, in which is fixed a round pin 372. The pin has bearing in a socket of a steel piece 374, which is fixed in and forms part of the fixed block 368. The pin 372 extends above the top of the piece 374 and passes through the hole 375 in one end of a shoe 376, which is rigidly connected to the pin 372 by a pin 377 passing through the shoe and the pin 372. Thus the shoe and the plate 371 are both rigidly attached to the pin 372 and oscillate thereon in carrying the tack from either side to a central position. The plate 371 has a recess 378 at the front edge, which recess is panned by a curved block 379, which is concentric at the inner face with the pivot-pin 372. The piece 374 of the fixed block extends forward in a projection 380, that is almost in contact with the inner face of the curved block, and which has a semi-cylindrical groove 381, which forms with a similar groove in the block 379 a cylindrical passage 382 when the block 379 is in a central position, as seen in Figs. 67 and 71. The size of the passage 382 is such that the head of the tack 383 passes through it without lodging.

384 is a plate secured to the top of the block 379 by the same bolts 385 by which the block is secured to the extensions of the plate 371. This plate 384 has a small recess 386 at its inner edge, adapted to receive the shank of the tack when the head of the tack is on top of the plate, in which position the tack is delivered from the end of that tack-race which is in line with the notch, the end of the other tack-race being closed by the unnotched edge 387 of the plate. Thus tacks are furnished only by that race which is in line with the notch 386. The lower end of the inner one of the parallel bars 347 of each tack-race is secured in a recess 388 each side of the extension or projection 380, the side 389 of the projection forming a continuation of that bar of the race. The outer race-bar 347 is continued in a line parallel with the side of face 389, extending to close proximity with the block



379, so that the tack is delivered into the recess 386, which is of such size as to receive but one tack at a time. When the tack is received in the recess, the shoe 376 and plate 371 swing on the pin 372 sufficiently to bring the tack to the groove 381, and the tack is drawn backward from the recess 386 of the plate 384, and drops through the passage 382 into the recess of the tack-deliverer.

10 The means for slipping the tack from the recess 386 will now be described. 390 is a lever pivoted at 391 to a block 392, that is fixed on posts 393, standing on the base-block 368. The trip-lever has a projection 394, against which impinges a projection 395 of the carriage as the carriage is just reaching its rear position, and thus the rounded lower end 396 of the lever 390 is pushed backward. This end 396 works in an aperture of the sliding bar 397, having bearing in the block 392. To the fore end of the sliding bar is connected by a hinge 398 an arm 399, bent forward at the lower end 400 and having on the under side a catch 401, which engages against the head of the tack as the arm is moved backward and pushes it from the recess 386 into the passage 382, through which it drops into the recess of the tack-deliverer, as before explained.

30 402 is a spring which holds the arm 399 in its vertical position, as shown, except in the event of an abnormal obstruction interfering with its backward movement, in which case the spring yields and prevents injury.

35 The tack-deliverer is rigidly attached to the carriage 163. It has a bar 403, which slides in a recess of the block 368. The bar has a vertical passage 404, which in the rear position of the bar is beneath and in line with the passage 382 and in the main part of its length the same diameter as the passage 382, so as to allow the tack-head to pass down it easily. To the bottom of the bar 403 are pivoted the jaws 405, the pivots being seen at 406. The tail ends of the jaws are pushed asunder by a spring 407, which is seen inserted between them. The spring keeps the fore ends of the jaws pressed together and closes the bottom of the tack-recess, which is made one-half in each of the jaws. The recess is shown with a cylindrical part 408, of equal diameter and in line with the passage 404, and a conical lower end 409, which extends nearly to the under side of the jaws. Thus when the jaws are in their rear position the point of the falling tack finds the bottom of the conical part 409 of the recess, while the tack is kept in upright position by the bearing of its head against the sides of the passage 404. (See Fig. 64.) The passage 404 is preferably made in a steel bushing 410, and is made flaring at the top, so as to form a guide for the set 411 of the tack driver or hammer. When the tack-deliverer is in its rear position, the boss of the bushing 410 is within the recess of the plate 371 and is almost in contact with the lower side of the point 380. As the carriage

163 and with it the tack-deliverer reach their forward position the hammer descends and forces the tack downward, the jaws 405 spreading apart at the fore end, allowing the passage of the tack and the hammer, the tack passing through the open slot or recess of the folder 207 into and through the edge 191 of the upper and the insole 208. The set or point 411 of the hammer is fixed in a vertically-sliding rod 412, having bearings in the carriage 163. The rod is driven down by a spiral spring 413, surrounding it, the lower end of the spring bearing on a collar 414 upon the rod and its upper end bearing against the carriage-frame. The upper end of the hammer-rod carries a head 415, with a flanged top 416.

417 is a spring-dog hinged to the carriage at the lower end, and whose upper end is beneath the flange 416 when the hammer is raised and serves to hold it in this position. 418 is a spring pressing the dog forward. 419 is a projection on the fixed frame 153, against which impinges a pin 420 on the dog as the carriage reaches its forward position, and by this means the dog is pushed from beneath the flange and the hammer descends. The hammer is raised again as the carriage moves backward by a lever 421, whose fore end 422 is forked and adapted to engage beneath the head 415. The rear end of the lever is depressed by an incline 423, which acts on an anti-friction roller 424, the incline being a fixture of the fixed frame 153. As the head 415 attains its upper position the dog 417 passes beneath the flange 416, and the hammer is held up until the dog comes against the projection 419, and the dog is again pushed from beneath the flange 416. The fore end of the lever 422 is depressed by a spring 425. The lever 421 is fulcrumed on a post 426 on the carriage.

The means for operating the tack-switch will now be described. It has already been said that a single tack from the discharging end of a tack-race enters the recess 386 and is by a movement of the switch carried to a central position nearly over the passage 382, into which it is discharged by slight rearward movement. It now remains to describe the mechanism for carrying the recessed part 386 of the plate 384 to the proper tack-race. The shoe 376 has at top a recess 427, in which works a switch-tongue 428. The switch-tongue is capable of limited oscillation on its end 429, which is shaped to fit in a rounded recess 430. The tongue 428 has at its under side a stud 431, which projects through a transverse slot 432 in the shoe 433 and the block 368. The stud enters the socket 367, passing through a slot 434, made endwise in the tubular pin or bar 366. The stud is preferably oblong in section, as seen in Fig. 73. 435 are headed pins whose heads fit easily the bore of the bar 366 and bear against the edges of the stud. 436 are spiral springs in whose adjacent ends are inserted the stems of the pins, so that these ends of the springs

have bearing against the heads of the pins. The other ends of the springs have bearing against the screw-plugs forming the ends of the bore. One of these plugs is seen at 437. 5 The other plug carries the ears forming part of the joint 365. This joint preferably includes a short link 365<sup>a</sup>, so as to avoid any binding of the bar 366 in its socket 367, the movement of the bar being straight, while 10 the end of the arm 361 moves in the arc of a circle. The endwise movement of the bar 366 causes the oscillatory movement of the tongue 428 when the latter is free to move. When, however, the tongue is not free, that 15 spring 436 against which the stud 431 bears contracts, and immediately the tongue is freed from its detent the spring expands and throws the tongue to one or the other side of the recess. 437 are stop pins or studs which 20 project inwardly in sockets between the pins 435, so as to limit the movement of the pins. The rear end 438 of the switch-tongue is wedge-shaped and adapted to receive the impact of a stud 439 upon the carriage, said stud 25 carrying, preferably, an anti-friction roller 440, which bears against one side of the wedged end 438 when the carriage moves forward and moves the tongue and shoe to one side, the movement being such as to carry the tack 30 to its central position. The position of the tongue in its recess is determined by the position of the arm 361, and the position of the tongue determines the direction in which the stud 439 moves the tack-carrier. In order to 35 prevent the stud 439 striking the salient angle 441 of the tongue, the tongue is always held to one side of the recess of the shoe, except when the carriage is in its rear position. In order to do this, the rear end 438 has at 40 bottom a projection 442, that passes through an aperture 443 in the shoe 376 and enters a recess 444 of the block 368. 445 is an arm hinged at the lower end 446 to the fixed frame and having a pin 447 connected by a 45 draw-spring 448 with a pin 449 upon the fixed block 368, the spring acting to draw the top of the arm forward. 450 is a point upon the arm which enters the recess 444 and prevents any change in the position of the tongue till 50 the point 450 is moved backward. The backward movement of the upper end of the arm is accomplished by a projection 451 of the carriage, which impinges against the projection 452 of the arm as the carriage is just reaching 55 its rear position, so that if the arm 361 is moved at any time, except when the carriage is in its rear position, the switch-tongue remains at rest until the carriage reaches its rear position, when the tongue is immediately 60 reversed and ready for the stud 439, with its roller 440, to act on the other side of the wedge-shaped point. Thus in no case can the stud-roller 440 strike the salient angle of the point, as it does not reach the point until the pro- 65 jection 451 has been carried out of contact with the projection 452, and, further, the

point 450 always precedes the stud 439 in the forward movement of the latter.

In Fig. 68 the parts are shown in position to take the tacks from the box 336, while in 70 Fig. 69 the parts are in position to take the tacks from the box 336<sup>a</sup>. In Fig. 70 the carriage is in its forward position, while in Fig. 71 the carriage is in its rear position.

It is proper that the machinery should come 75 to rest speedily when desired and in a position most favorable to the application of the shoe to be lasted, and I will now describe the brake mechanism, which is shown in Fig. 90. The treadle-lever 119 is keyed to the 80 shaft 120, which forms the fulcrum of the lever. This shaft has bearing in the side of the frame 101, and carries upon the outer side of the frame an arm 453, having a pin 85 or stud 454, bearing or adapted to bear against the under side of the arm 455 of a bell-crank lever fulcrumed at 456 to the frame 101. The upper arm 457 of the bell-crank carries a friction-shoe 458, connected to the arm 457, preferably on a pivot 459, and bearing against 90 the periphery of an eccentric 460, keyed to the cam-shaft 160. The free end of the arm 455 is connected by a draw-spring 462 to a fixed point on the frame 101 beneath, so as to 95 draw down the free end of the arm 455 whenever the treadle-lever 119 is in its forward position, and consequently the arm 453 is in its lower position. This position of the parts is shown in full lines in Fig. 90, the brake- 100 shoe being forced against the eccentric with the whole force of the spring 462, and the cam-shaft is brought to rest before the salient part 461 of the cam has passed the shoe. If 105 the force of the spring is not great enough to prevent a single passage of the salient part 461 beneath the shoe 458 after the lever 119 has reached its forward position, no injury is done to the mechanism, for the spring 462 allows the shoe to move outward.

The position shown by broken lines in Fig. 110 90 is the position of the parts when the machine is running.

I claim as my invention—

1. The combination, in a lasting-machine, of the treadle-lever 119, having a curved edge 115 or part 122, a friction-clutch thrown into active position by such curved part, the pinchers, pincher-lever, and the pincher-lifting spring 128, connected with the treadle-lever and pincher-lever, substantially as and for 120 the purpose set forth.

2. The combination, in a lasting-machine, of the treadle-lever 119, the bell-crank 124 125 125, the pinchers, pincher-lever, the spring 128, and dash-pot 136 137 138, connected together and adapted to operate substantially as and for the purpose set forth.

3. In a lasting-machine, the combination of a fixed frame carrying the tack-boxes, tack-switching device having a movable tongue 130 and the guide and feeder for the work, and a reciprocating carriage carrying a stud for



actuating the tack-switch, the pressing and folding devices, and the devices for drawing and crimping the leather, substantially as set forth.

5 4. In a lasting-machine, a pusher-head having yielding presser-bars and a vertically-yielding folder 207, pivoted in the head, substantially as set forth.

10 5. In a lasting-machine, the folder-bar having pivotal connection 227 with the pusher-head 212 and having a depending arm 228 bearing against a spring 230, said spring acting to press the forward end of the folder downward, for the purpose set forth.

15 6. The combination, in a lasting-machine, of a folder having one end adapted to act upon the edge 191 of the leather, fulcrumed to the pusher-head 212, and having means to press the forward end of the folder downward, for the purpose set forth.

20 7. The combination, in a lasting-machine, of the folder-bar fulcrumed to the pusher-head and having a part 228, a spring 230 and screw 232, against which the part 228 bears, and a screw 231, adapted to adjust the power of the spring, substantially as set forth.

25 8. The combination, in a lasting-machine, of the folder-bar having an arm 228, the spring-block 229, spring 230, and adjusting-screws 30 231 and 232, all adapted to act substantially as and for the purpose set forth.

35 9. In a lasting-machine, a pusher having yielding presser-bars 235, with guide-wings 237 at the sides, and the dog 241, adapted to hold the presser-bars in retracted position, substantially as set forth.

40 10. In a lasting-machine, a pusher-head 212, supported on a bar 213, having bearing 214 on the carriage 163 and having limited endwise movement in its bearing, with suitable means to prevent the turning of the bar 213 in its bearing 214, for the purpose set forth.

45 11. In a lasting-machine, the pusher-head 212, having a supporting-bar 213, with bearing in the carriage 163, and an extension 222, and a post 223, in which the extension 222 has endwise movement, substantially as and for the purpose set forth.

50 12. The combination, in a lasting-machine, of the pusher-head 212, having a supporting-bar 213, with bearing 214 on the carriage 163, with spring 220 within the bearing, forcing the pusher forward, and nut 218 upon the bar, limiting the forward movement of the pusher-bar in its bearing, substantially as set forth.

55 13. The combination, in a lasting-machine, of a pusher-head 212, supported in a bar 213, having bearing 214 on the carriage, the spring 220, nut 218, extension 222, a fixed post 223, 60 through which the extension passes, and a nut 224, limiting the forward movement of the pusher-head, substantially as set forth.

65 14. In a lasting-machine, the combination of the bell-crank lever 298 300, carrying the presser-foot 296, the spring 303, adapted to lift the presser-foot, and the cam-wheel 171,

having a cam 302, adapted to force the presser-foot down on the work.

15. The combination, in a lasting-machine, of the presser-foot 296, connected to the arm 70 298 by a pivot 297, the spring 304, and screw 306, and the fixed pin and bracket 307 for the end of the spring and for the screw, respectively, all arranged and adapted to operate as set forth. 75

16. The combination, in a lasting-machine, of the guide 274, having a lip 275, adapted to engage the edge of the insole and having inward and outward adjustment, two tack-boxes 80 336 and 336<sup>a</sup>, containing tacks of different lengths, and suitable mechanism for throwing the tack-boxes into and out of service and automatically adjusting the position of the guide 274, substantially as set forth.

17. The combination, in a lasting-machine, 85 of the tack-boxes, the feed-finger 309, the tack and switching device, a rock-shaft having operative connection with said switching device, an arm 321 for oscillating said feed-finger, the reciprocating arm 323, having connection with arm 321, and an arm connecting 90 the rock-shaft with arm 323, whereby the point of connection between arms 321 and 323 will change as the shaft rocks, substantially as set forth. 95

18. The combination, in a lasting-machine, of the tack-boxes, the tack-switching device, a rock-shaft having operative connection with said switching device, the crimping mechanism, an arm for operating said crimping mechanism, and a pin for holding said arm inactive, having connection with and operated by said rock-shaft, substantially as set forth. 100

19. The combination, in a lasting-machine, of a pincher bar or spindle having rotary and 105 endwise movement and provided with a head 211, carrying a spring-latch 265, a lever 259, fulcrumed to the fixed frame and carrying a pin or stud 263, adapted to engage the latch, the reciprocating carriage 163, carrying a stud 110 268, engaging the lever 259, and spring 262, all constructed and arranged to operate substantially as and for the purpose set forth.

20. In a lasting-machine, a rotary tack-box having a tack-race conveying tacks from the 115 box, and a shaft carrying a hammer adapted to tap the race and having an arm 358, tappets 359 upon the box, acting on the arm 358, and a spring 354<sup>a</sup>, all adapted to operate substantially as and for the purpose set forth. 120

21. The combination, in a lasting-machine, of a rotary tack-box with a fixed end through which passes a tack-race conveying the tacks from the interior of the box, a rock-shaft carrying a brush 352, shaft 353, arm 354, and 125 hammer 355, adapted to tap the race, tappet or stud 359 on the box, and a spring 254<sup>a</sup>, all adapted to operate substantially as set forth.

22. The combination, in a lasting-machine, of two tack-boxes having races discharging at 130 different points, and an oscillatory block 379, with a curved face having a single recess 386

and closing the ends of the races except for said single recess 386, adapted to receive a single tack carried by the movement of the block to a point between the races, substantially as set forth.

23. The combination, in a lasting-machine, of the tack-races, the block 379, pin 372, shoe 376, tongue 428, working in a recess of the shoe and having a depending stud 431, depending from the carriage, and suitable means for swinging the tongue 428 on its pivot, substantially as and for the purpose set forth.

24. The combination, in a lasting-machine, of two tack-boxes having races discharging at different points, an oscillating block 379, with a curved face closing the ends of the races except for the recess 386, adapted to receive a single tack, and the piece 374, spanned by the block 379 and having a groove to receive the tack carried by the movement of the block, substantially as set forth.

25. The combination, in a lasting-machine, of the block 379, pin 372, shoe 376, tongue 428, with projection 442, the stud 439 on the carriage, the arm 445, with point 450 and having a projection 452, a draw-spring 448, connecting the arm to a fixed point, and the stud 451 on the carriage, adapted to impinge against the projection 452, all substantially as and for the purpose set forth.

26. The combination, in a lasting-machine, of the two tack-races discharging at different points, the block 379, with recess 386 and a semi-cylindrical recess 378, the fixed block 368, having a semi-cylindrical recess 381, tack-carrier 403, with passage 404, and spring-jaws 405 to receive the tack, substantially as set forth.

27. The combination, in a lasting-machine, of the hollow bar 366 for the purpose set forth, the arm 361, rock-shaft 249, arm 249<sup>a</sup>, rod 147, and treadle 144, substantially as and for the purpose set forth.

28. The combination, in a lasting-machine, of the pincher-bar head 211, lever 259, with pin 263, the detent-pin 257, lever 254, rod 253, having a slot 252, cam 250, and pin 251, working in a slot 252, rock-shaft 249, arm 249<sup>a</sup>, rod 147, and treadle 144, substantially as and for the purpose set forth.

29. The combination, in a lasting-machine, of the rock-shaft 249, having a cam 250, connected with the detent-pin 257 of the lever 259, and an arm 361, connected with the tack-switching mechanism, causing the simultaneous adjustment of the crimping and tack-feeding mechanism, substantially as and for the purpose set forth.

30. The combination, in a lasting-machine, of the guide 274 on rod 276, nut 279 on said rod, with stud 280, and worm-cam 250 on a rock-shaft 249, with suitable mechanism for rocking the shaft, substantially as and for the purpose set forth.

31. The combination, in a lasting-machine, of the guide 274, attached to a collar 278, rod 276, on which the collar turns but has no end-

wise movement, a nut 279 on a screw-threaded part of the rod, a stud 280 on the nut, working through a slot 283, the worm-cam 250, and the rock-shaft 249, with suitable mechanism for rocking said shaft.

32. The combination, in a lasting-machine, of the rock-shaft 249, having an arm 361, the tack-switching mechanism with which it is connected, a worm-cam 250, and the guide mechanism operated by the latter, substantially as and for the purpose set forth.

33. The combination, in a lasting-machine, of the rock-shaft 249, with cam 250, with spiral groove receiving a stud on the guide-rod 276, a pin 251, operating the detent-pin 257, the guide, and lever 259, substantially as and for the purpose set forth.

34. The combination, in a lasting-machine, of the feed-finger 309, attached to a spindle 311, having limited rotary and vertical reciprocation, an arm 321 on the spindle, an arm 323, engaging the arm, and a sliding bar 324, with a cam-stud 326, and rotary cam 171<sup>a</sup>, having a groove 327, receiving the stud 326, substantially as and for the purpose set forth.

35. The combination, in a lasting-machine, of the feed-finger spindle 311, arm 321, arm 323, with yoke through which the arm 321 passes, sliding bar 324, stud 326, cam 171<sup>a</sup>, and spring 328, all constructed and adapted to operate substantially as set forth.

36. The combination, in a lasting-machine, of the feed-finger, feed-finger spindle, sliding bar 324, arm 323, arm 321, and arm 321<sup>b</sup>, with stop-screw 321<sup>a</sup>, limiting the forward movement of the arm 321, substantially as and for the purpose set forth.

37. The combination, in a lasting-machine, of the feed-finger, feed-finger spindle, sliding bar 324, rod 323, arm 321, working in a mortise of the rod 324, an arm 332, having an orifice through which the rod 323 passes, and an arm 330 on the rock-shaft 249, engaging the arm 332, substantially as and for the purpose set forth.

38. The combination, in a lasting-machine, of the slide-bar 324, arm 323, with yoke 329, arms 330 332, arm 321, having a recess 335, and feed-finger spindle 211, substantially as and for the purpose set forth.

39. The combination, in a lasting-machine, of the tack-switching mechanism, a rock-shaft, a worm on said shaft, the guide having a stud engaged by said worm, the feed-finger, an arm 321 for oscillating said finger, a connecting-arm 323 for oscillating said arm 321, and a connection between the said arm 323 and rock-shaft for imparting an oscillatory movement to the arm 323, whereby the point of connection between said arms will vary as the shaft rocks, substantially as set forth.

40. The combination, in a lasting-machine, of the pincher-rod 172, jaws 173 174, hinged to the rod, and a sleeve upon the rod, with pins 178, 179, and 180, carrying rollers which bear upon the jaws to open and close the jaws by the upward and downward movement of

the sleeve upon the rod, substantially as set forth.

41. The combination, in a lasting-machine, of the cam 286 287 288, rock-shaft 249, rod 5 290, hanging arm 291, with catch 292, and a spring 294, substantially as and for the purpose set forth.

42. The combination, in a lasting-machine, of the rock-shaft 249, with a cam 250 and a 10 pin 251 thereon, connected with the mechanism governing the crimping operation of the pinchers, arm 330, connected with the mechanism governing the feed of the work in the machine, the arm 361, connected with the 15 tack-switch mechanism, and the cam 286 287 288, connected with the mechanism governing the closing of the pinchers, so that these parts are adjusted simultaneously by the simple turning of the shaft a part of a revolution, 20 substantially as set forth.

43. The tack driver or hammer having bearing on the carriage and having a rod or stem 412, with a flanged head 415 416, a lever 421, whose forked end 422 embraces the head and 25 engages beneath the flange 416, and an incline 423 on the fixed frame, adapted to force the rear end of the lever down as the carriage moves backward, substantially as and for the purpose set forth.

44. The combination, in a lasting-machine, of the hammer-rod with flanged head, the forked lever engaging the head, the incline 423, adapted to raise the forked end 422, and the spring 425, acting to depress the said 30 forked end, substantially as and for the purpose set forth.

45. The combination, in a lasting-machine, of the flanged hammer-bar and hammerspring-

dog 417 on the carriage, adapted to engage 40 beneath the flange 416 of the head, and the projection 419 on the fixed frame, acting to trip the dog from the flange 416 as the carriage attains its forward position, substantially as and for the purpose set forth.

46. The combination, in a lasting-machine, 45 of the tack driver or hammer having a rod 412, depressing-spring 413, and flanged head 415 416, the lifting-lever 421, incline 423, spring 425, spring-dog 417, and projection 419, all arranged and adapted to operate substan- 50 tially as and for the purpose set forth.

47. The combination, in a lasting-machine, of the tack-switching mechanism and crimping mechanism with a treadle having three 55 working positions and connected to the arm of a rock-shaft 249, having connection with the tack-switching mechanism and crimping mechanism and causing the simultaneous adjustment of the above mechanisms, substan- 60 tially as and for the purpose set forth.

48. The combination, in a lasting-machine, of the tack-switching mechanism and crimping mechanism with a treadle 144, having 65 three working positions and connected to the arm of a rock-shaft 249, said shaft having connection with different portions of the mechanisms and imparting to them simultaneous adjustment to meet the requirements 70 in lasting the toe, heel, and side of the shoe, respectively, substantially as and for the purpose set forth.

CHARLES SINNING.

In presence of—  
SAML. KNIGHT,  
BENJN. A. KNIGHT.