

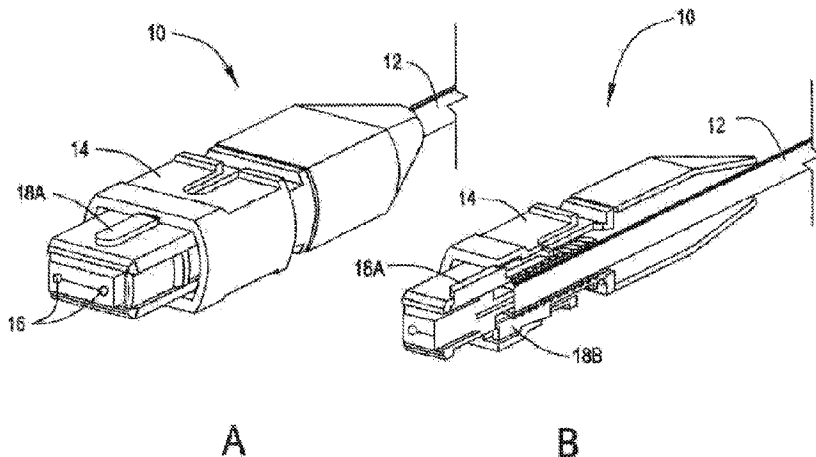

(86) Date de dépôt PCT/PCT Filing Date: 2015/06/04
 (87) Date publication PCT/PCT Publication Date: 2016/01/07
 (45) Date de délivrance/Issue Date: 2023/01/24
 (85) Entrée phase nationale/National Entry: 2016/11/28
 (86) N° demande PCT/PCT Application No.: IB 2015/001127
 (87) N° publication PCT/PCT Publication No.: 2016/001744
 (30) Priorité/Priority: 2014/06/30 (US14/319,132)

(51) Cl.Int./Int.Cl. *G02B 6/38* (2006.01)
 (72) Inventeurs/Inventors:
 GOOD, PAUL MICHAEL, US;
 AYRES III, WILLIAM, US;
 HEFFNER, GREG, US
 (73) Propriétaire/Owner:
 US CONEC LTD., US
 (74) Agent: GOWLING WLG (CANADA) LLP

(54) Titre : CONNECTEUR DE FIBRES OPTIQUES MPO A POLARITE REVERSIBLE
 (54) Title: REVERSIBLE POLARITY MPO FIBER OPTIC CONNECTOR



(57) **Abrégé/Abstract:**

A multi-fiber, fiber optic connector (10) is provided having a housing (14) having a first end for receiving a multi-fiber fiber optic cable (12) and a second end having openings for the fibers from the cable. First and second keys (18A,B) for setting the polarity of the fibers within the connector located on opposing sides of the connector. The connector has either one of guide pins or guide pin receiving holes (16) for guiding the connection with a second connector. The keys (18A,B) are movable between a first active position and a second retracted position, such that when one of the keys is in the first active position, the fibers are presented within the connector in a first polarity and when the second key is in the first active position, the fibers are presented within the connector in a second polarity reversed from the first polarity.

(12) INTERNATIONAL APPLICATION PUBLISHED UNDER THE PATENT COOPERATION TREATY (PCT)

(19) World Intellectual Property
Organization
International Bureau(10) International Publication Number
WO 2016/001744 A1(43) International Publication Date
7 January 2016 (07.01.2016)(51) International Patent Classification:
G02B 6/38 (2006.01)(21) International Application Number:
PCT/IB2015/001127(22) International Filing Date:
4 June 2015 (04.06.2015)

(25) Filing Language: English

(26) Publication Language: English

(30) Priority Data:
14/319,132 30 June 2014 (30.06.2014) US

(71) Applicant: NEXANS [FR/FR]; 8, rue du Général Foy, F-75008 Paris (FR).

(72) Inventors: GOOD, Paul Michael; 2418 Helena Road, Lancaster, Pennsylvania 17603 (US). AYRES III, William; 4466 Fairway Ct., Center Valley, Pennsylvania 18034 (US). HEFFNER, Greg; 59 Summerlyn Drive, Ephrata, Pennsylvania 17522 (US).

(74) Agent: FERAY, Valérie; Ipsilon Feray Lenne Conseil, Le Centralis, 63 avenue du Général Leclerc, F-92340 Bourgl-la-Reine (FR).

(81) Designated States (unless otherwise indicated, for every kind of national protection available): AE, AG, AL, AM,

AO, AT, AU, AZ, BA, BB, BG, BH, BN, BR, BW, BY, BZ, CA, CH, CL, CN, CO, CR, CU, CZ, DE, DK, DM, DO, DZ, EC, EE, EG, ES, FI, GB, GD, GE, GH, GM, GT, HN, HR, HU, ID, IL, IN, IR, IS, JP, KE, KG, KN, KP, KR, KZ, LA, LC, LK, LR, LS, LU, LY, MA, MD, ME, MG, MK, MN, MW, MX, MY, MZ, NA, NG, NI, NO, NZ, OM, PA, PE, PG, PH, PL, PT, QA, RO, RS, RU, RW, SA, SC, SD, SE, SG, SK, SL, SM, ST, SV, SY, TH, TJ, TM, TN, TR, TT, TZ, UA, UG, US, UZ, VC, VN, ZA, ZM, ZW.

(84) Designated States (unless otherwise indicated, for every kind of regional protection available): ARIPO (BW, GH, GM, KE, LR, LS, MW, MZ, NA, RW, SD, SL, ST, SZ, TZ, UG, ZM, ZW), Eurasian (AM, AZ, BY, KG, KZ, RU, TJ, TM), European (AL, AT, BE, BG, CH, CY, CZ, DE, DK, EE, ES, FI, FR, GB, GR, HR, HU, IE, IS, IT, LT, LU, LV, MC, MK, MT, NL, NO, PL, PT, RO, RS, SE, SI, SK, SM, TR), OAPI (BF, BJ, CF, CG, CI, CM, GA, GN, GQ, GW, KM, ML, MR, NE, SN, TD, TG).

Published:

- with international search report (Art. 21(3))
- before the expiration of the time limit for amending the claims and to be republished in the event of receipt of amendments (Rule 48.2(h))

(54) Title: REVERSIBLE POLARITY MPO FIBER OPTIC CONNECTOR

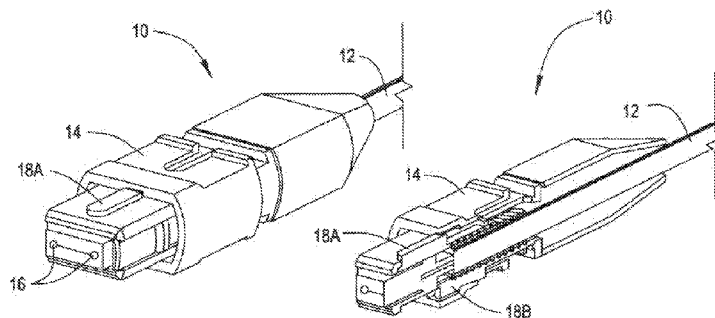

FIG. 4A

FIG. 4B

(57) Abstract: A multi-fiber, fiber optic connector (10) is provided having a housing (14) having a first end for receiving a multi-fiber fiber optic cable (12) and a second end having openings for the fibers from the cable. First and second keys (18A,B) for setting the polarity of the fibers within the connector located on opposing sides of the connector. The connector has either one of guide pins or guide pin receiving holes (16) for guiding the connection with a second connector. The keys (18A,B) are movable between a first active position and a second retracted position, such that when one of the keys is in the first active position, the fibers are presented within the connector in a first polarity and when the second key is in the first active position, the fibers are presented within the connector in a second polarity reversed from the first polarity.

WO 2016/001744 A1

REVERSIBLE POLARITY MPO FIBER OPTIC CONNECTOR

RELATED APPLICATION:

This application is related to U.S. Patent Application No. 13/934,378,
5 filed on July 3, 2013.

BACKGROUND:

FIELD OF THE INVENTION:

The present arrangement relates to fiber optic connectors. More particularly, the present arrangement relates to fiber optic connectors with
10 reversible polarity.

DESCRIPTION OF THE RELATED ART:

In the area of fiber optic connections, typical fiber optic systems usually have to establish a bi-directional pathway between a transmitter port on a first element and receiver port on a second element and vice versa.
15 See for example schematic Figure 1. In order for such a bidirectional systems to function, it is a requirement that one end of a fiber be connected to the light emitting source of a first equipment, often a type of laser or light emitting diode, and the other end connected to a receiver port on a second equipment. For the second fiber in the bi directional pathway, the other
20 fiber needs to be connected to the light source on the second equipment and, at the other end, the receiver port of the first equipment.

Fiber optic connectors used for larger high-speed fiber optic systems often use multi-fiber cables supporting many bi-directional pathways. In one example the cables typically have 12 fibers in the cable, with the corresponding connectors for such cables housing multiple fiber optic members within the same connector body. Such a twelve fiber arrangement can support six of such bi-directional (duplex) pathways.

These connectors used for such high-speed fiber optic systems often employ what are termed multiple fiber optic members, called MPO (Multiple-Fiber Push-On/Pull-off) connectors and they typically support the twelve fiber (six duplex channel) arrangements within the same connector body. Using Figure 1 showing a single two way channel, there can be many segments of fibers between two components, each representing a fiber optic cable with a connector. In some cases, between segments, the fibers in the connector of a first segment pass directly across to the fibers of the second segment. However, in some cases, in order for the transmission signal to end up at the correct receiver port, at least one segment connection, the connectors must have the pin/fiber input/output on one side flipped so that the transmission signal exits on the other fiber in the channel.

This situation is referred to as connector "polarity" for each segment. A fiber cable segment with two connectors at either end that result in the same polarity across the segment is referred to as method A and a fiber cable segment with two connectors at either end that result in a flip in the

polarity across the segment is referred to as method B. In Figure 1, the first four segments are method A polarity, the fifth segment is method B polarity exhibiting a flip in the light pathways across the two fibers. Depending on the various fiber optic equipment arrangements, in the prior art, to make the correct connections, the installer needs to select cable segments (i.e. pre-terminated lengths of cable) that have the correct polarity.

This holds true for larger MPO connectors where the associated cables must still also eventually result in one end of a fiber being connected to a source and the other end connected to a receiver and vice versa for each bi-directional pathway supported. As shown in Figure 2, the top shows Method A polarity where the blue fiber starts on position 1 on one connector on one side of the segment and is at the same location (position 1) on the other connector on the other side of the segment. This method A polarity arrangement would be a straight forward connection that passes the same connection polarity to the next segment of the installation.

The bottom part of Figure 2 shows Method B polarity where the blue fiber starts on position 1 on one connector on one side of the segment and is at the opposite location (position 12) on the other connector on the other side of the segment. With Method B polarity the remaining fibers in the connector on the second side of the segment are all also transposed in position vis-à-vis the first connector. The management of connections in

such MPO connectors between sources and receivers and the polarity of such connections is described in the standard TIA-568-C.3. This method B polarity arrangement would be a connection that reverses the connection polarity going forward to the next segment of the installation.

5 As shown in Figure 1, in order for the light signal from one source to reach a receiver at the other end there typically must be an odd number of 'flips' in the cabling, where a 'flip' indicates a method B polarity segment, so that the fiber in connector position 1 is connected to position 2 on the other side, the fiber in connector position 2 is connected to position 1 on the other
10 side, etc...

 These flips can be achieved via individual fiber assemblies and/or in the adapters that connect different fiber optic cabling segments together for example as shown in the basic design in Figure 1 at segment 5. However, since fiber optic networks are dynamic environments, connections are often
15 added or subtracted and, as such, the number of required flips changes within the cabling arrangement between equipment. Ensuring that there are an odd number of flips then requires one or more of the fiber optic assemblies' polarity to be changed as the connections are added or subtracted. This requires the installers and/or end users to stock assemblies
20 of different polarities and lengths for every possible network configuration, given that assemblies are pre-terminated with a fixed polarity.

For example, the polarity of fiber optic systems is carefully considered during the design phase and is generally fixed upon completion because many patch cords come pre-terminated and the polarity of the connector(s) is set at manufacture. For example a patch cord having connectors for its end set at a first polarity (i.e. method A or method B) can only be used for example in Figure 1 at certain segment locations. If for any reason the configuration changed, as will be explained in more detail below, the installer may require a new patch cord, possibly of a different length, and having its two connectors set at a different polarity. Consequently, end users must carry a large inventory of pre-terminated assemblies or order additional parts to allow for reconfigurations of the network topology.

The polarity of an MPO (Multiple-Fiber Push-On/Pull-off) style connector, whether it be method A or method B is determined by the relationship between the fibers and a “key” on the connector body, which is why polarity is sometimes referred to as “keying.”

Prior art Figure 3 shows a standard prior art MPO connector that has a single fixed key on its body. Thus, the polarity is set at the time of manufacture. Although some prior art arrangements have the ability to change the key/polarity of the connector, these solutions require the disassembling and reassembling of existing assemblies or the purchase of

new assemblies. This increases either labor costs or material costs associated with these networks/connectors.

OBJECTS AND SUMMARY:

The present arrangement overcomes the drawbacks associated with
5 the prior art and provides for a reversible polarity MPO type connector that can be applied without worry of previous installation types or designs. The reversible polarity connector reduces installer's and customer's inventory, installation time, and ultimately lowers their cost.

Such a connector employs a movable key that allows a user to reverse
10 the polarity of the connector without the need to open the connector housing. Additionally, the present connector can be employed in conjunction with a universal connector pin arrangement that also allows a user to push forward or retract the MPO guide pins to assist in accommodating the use of such connectors in both polarities, again without
15 the need for opening the connector.

To this end, the present arrangement provides for a multi-fiber, fiber optic connector, having a housing having a first end for receiving a multi-fiber fiber optic cable and a second end having openings for the fibers from the cable. First and second keys for setting the polarity of the fibers within
20 the connector located on opposing sides of the connector. The connector

has either one of guide pins or guide pin receiving holes for guiding the connection with a second connector.

The keys are movable between a first active position and a second retracted position, such that when one of the keys is in the first active position, the fibers are presented within the connector in a first polarity and when the second key is in the first active position, the fibers are presented within the connector in a second polarity reversed from the first polarity.

BRIEF DESCRIPTION OF THE DRAWINGS:

The present invention can be best understood through the following description and accompanying drawings, wherein:

Figure 1 is a schematic view of a typical fiber optic arrangement of fiber optic equipment and connectors;

Figures 2A - 2D are a schematic view of fiber optic arrangements and polarity configurations;

Figure 3 shows a prior art fixed key MPO type connector;

Figures 4A and 4B show a reversible polarity connector, in accordance with one embodiment;

Figure 5 shows two reversible polarity connectors in an adapter, in accordance with one embodiment;

Figures 6A and 6B illustrate an exemplary fiber optic arrangement making use of reversible polarity connectors, in accordance with one embodiment;

Figure 7 shows a reversible polarity connector with retractable guide pins, in accordance with another embodiment;

Figure 8 shows a reversible polarity connector with retractable guide pins, in accordance with another embodiment;

5 Figure 9 shows a reversible polarity connector with retractable guide pins, in accordance with another embodiment; and

Figure 10 shows a reversible polarity connector with retractable guide pins, in accordance with another embodiment.

DETAILED DESCRIPTION:

10 In one embodiment of the present arrangement as shown in Figures 4A and 4B a connector 10 is provided at the end of a multi fiber cable 12. Connector 10 has a housing 14, guide pins/guide pin openings 16 and keys 18A and 18B. It is noted that connector 10 is shown with guide pin openings 16 (female) but all of the features of the present arrangement are
15 equally applicable to male/pins extended connectors 10 as well. As a basic explanation the “key” sets the order for which the fibers in connector 10 are presented to an additional opposing connector 10. A key that is ‘active’ is one that is in position to engage with an adapter. If a key is said to be reversed then it means that the key on the opposite side of the
20 connector (that being the one that was not previously ‘active’) is now ‘active’. If connectors of both regular and reversed active keys are compared, it would be found that the fibers in connector 10 are presented to

an opposing connector in opposite order. The setting of the key 18 is what sets the polarity (arrangement of fibers from cable 12) for connector 10 from the perspective of an opposing connector.

Thus, as shown in Figure 4A, key 18A on the top of connector 10 is in a forward extended position. As shown in cut-away Figure 4B, key 18A on the top of connector 10 is in a forward extended position with key 18B on the bottom of connector 10 in the retracted position within housing 14. Such an arrangement allows for keys 18A and 18B, on both sides of connector 10, to be alternately extended and retracted in order to achieve the desired polarity without disassembling the connector body. When cable 12 contains at least one of these connectors 10, keys 18A and 18B on top and bottom can be adjusted to determine whether the assembly (cable with a MPO connector on each end) is a 'Method A' or 'Method B' as referred to in the standards.

Applicants note that there are two keys 18A and 18B on connector 10 so that a fiber optic segment having two connectors 10 on either end may exhibit both A & B polarities options. When a user wants a fiber optic segment to be polarity A, the user simply sets the keys 18A on the tops of connectors 10 on both ends of the segment to the same setting, i.e. both keys 18A forward and active with both keys 18B retracted within housing 14) so that fibers exhibit the same presentation order on both sides of the fiber optic segment. To reverse to method B polarity, one of the keys such

as a key 18A on one of the two connectors 10 is retracted into housing 14 and the other key 18B on that same connectors is pushed forward to active. This allows for the polarity of a single assembly or cable to be changed from A to B or B to A.

5 When keys 18A or 18B are retracted, nothing physically changes with fibers 12 in connector 10. Rather, the only change with connector 10 is a flipping of the order fibers 12 are presented to opposing connectors because the active or forward key 18A/18B is switched from one side of connector 10 to the opposite side.

10 It is noted that nothing is moving within housing 14. Fiber position number is always referenced by holding the key up and looking from left to right. By having two keys 18A/18B on opposing sides of connector 10 with the ability to activate one key or the other, this changes the definition of “up” for that connector. In other words with two movable keys 18A and 18B
15 on connector 10 and the ability to easily change which key is active (used to determine which way is “up”) a user can reverse the order of the fibers presentation on a connector 10 on one end of an assembly only, switching the segment from a Method A to a Method B or vice-versa.

 Moreover, in the cut away example Figure 4b, connector 10 shows top
20 key 18A activated (extended out) and bottom key 18B retracted back into connector 10. As is evident from Figures 4A and 4B, keys 18A and 18B can be used to change the polarity of connector 10 without the need for opening

any part of connector 10, such as housing 14, unlike the prior art configurations.

As shown in Figure 5, which shows two connectors 10 fitted into an adapter 20. Such keys 18A (only top keys 18A are visible in Figure 5) can be operated by simply sliding key 18A forward and backward, or by pressing the key below the surface of the housing and locking arrangement, located towards the front of housing 14 of connector 10. Each key 18A and 18B can thus be operated independently with non-specialized tools and without disassembly of the connector, as the tab for keys 18 is accessible through an opening in housing 14. It is noted that in Figure 5, such a tab for adjusting keys 18, during a connection to another connector 10 via adapter 20, would actually fit within adapter 20. The other slide mechanism shown in Figure 5 is related to another feature regarding an adjustable guide pin arrangement discussed in more detail below.

One exemplary arrangement for demonstrating the usefulness of connectors 10 is shown in Figures 6A and 6B. In Figure 6A a first equipment # 1 is shown connected to a second equipment # 2 using five spans of fiber with MPO type connectors on such spans at four locations (# 1 - # 4). That is, at each location # 1 - # 4, there is an adapter 20 and two opposing MPO connectors, one for each segment on either side of the adapter. The connectors at points # 1 through # 3 each maintain the same polarity from the prior segment (Method A polarity), and at connector # 4 the polarity

reverses (Method B polarity) before entering equipment 2 as shown in the figure.

Turning now to Figure 6B, assuming that owing to some required connection change, equipment # 1 now needs to be connected to equipment # 3 at a different location instead of equipment # 2. As a result the third segment of fibers after location # 2 and their connector facing segment 2 on the opposing side of location # 2 now needs to be reversed in polarity (Method B) whereas in the prior Figure 6A arrangement (connected to equipment # 2) that same connector/segment would have simply retained the same polarity (Method A). As a practical matter, in the prior art, an installer or user would have had to replace the fiber segment 3 with a new patch fiber segment having a different (opposite) pre-terminated fixed polarity connector to fit into the adapter at location # 2 in order to change the polarity of the connection now entering into equipment 3. Or, using prior art connectors that could change polarity, the user would have to open the housing of the connector on the third fiber segment after location # 2 and change the polarity, possibly damaging/diminishing that connector and the fiber connections therein.

However using the present arrangement, assuming the connector for fiber segment three exiting location # 2 was a connector 10 according to the present arrangement, connector 10 could simply be removed from the adapter 20 at location # 2 have the appropriate key 18 retracted/moved

forward, and reinserted into the adapter as shown in Figure 6B, changed from Method A to Method B polarity.

In another embodiment of the present invention as shown in the following Figures 7-10, in addition to connector 10 being a reversible polarity
5 connector 10 using keys 18A and 18B as explained above, such connectors 10 may also have a retractable guide pin arrangement 50 so that connector 10, in addition to having reversible polarity also can exchange between male (extended) and female (retracted) guide pin configurations.

As shown in Figure 7, connector 10 has a guide pin arrangement 50
10 shown in the extended male configuration. Guide pin arrangement 50 includes an attached retraction tabs 52 (one opposing side not shown) located on either side of the connector. In Figure 8 connector 10 has the same retractable guide pin arrangement 50 shown in the extended male configuration. In the embodiment shown in Figure 8, guide pin arrangement
15 50 includes attached retraction tabs 52B located on the top of connector 10. In Figure 9 connector 10 again has the same retractable guide pin arrangement 50. In the embodiment shown in Figure 9, guide pin arrangement 50 includes a single attached retraction tab 52C located on the top of connector 10 in between a bifurcated arrangement of tab(s) 18C to
20 change the polarity of key 18A. In Figure 10 connector 10 has the same retractable guide pin arrangement 50. In the embodiment shown in Figure

10, guide pin arrangement 50 are spring biased via biasing springs 51 (internal) and held in position using pin locks 54 on top of connector 10.

As an example of how the embodiment with retractable pins 50 supplements the usefulness of the reversible polarity of connector 10 using
5 keys 18, Applicants note that standard equipment typically has pins in it, but some of the components in given channel (e.g. a 4 connector channel of patch cord, trunk, patch cord, trunk, patch cord etc..) will have pins and the rest will not since it is always required to mate a male to a female. So if a user were to add or subtract fiber segments/elements from the channel,
10 even if the polarity can be changed, they may or may not end up with connectors with pin arrangements that can be mated together. By adding switchable guide pins this possible drawback can be overcome.

While only certain features of the invention have been illustrated and described herein, many modifications, substitutions, changes or equivalents
15 will now occur to those skilled in the art. It is therefore, to be understood that this application is intended to cover all such modifications and changes that fall within the true spirit of the invention.

What is claimed is:

1. A multi-fiber, fiber optic connector comprising:
 - a connector body defining a first surface and a second surface;
 - a first key structure slidably positioned within a first slot defined on the first surface of the connector body;
 - a second key structure slidably positioned within a second slot defined on the second surface of the connector body;
 - a key housing enclosing a portion of the first surface of the connector body and the second surface of the connector body,
 - wherein the first key structure is slideable relative to the first slot and the key housing and configured to be received within the key housing,
 - wherein the second key structure is slideable relative to the second slot and the key housing and configured to be received within the key housing, either one of guide pins or guide pin receiving holes for guiding a connection with a second connector,
 - wherein, in operation, a polarity of the fiber optic connector is selectively adjusted by ingressingly sliding the first key structure into the key housing within the first slot and retracting the second key structure relative to the key housing within the second slot such that the second key structure extends from the key housing while the first key structure remains at least partially within the key housing.
2. The connector of claim 1, wherein a distal end of the first key structure is configured to be covered by the key housing when the first key structure is slid within the key housing.
3. The connector of claim 1, wherein a portion of the first key structure and a portion of the second key structure remains within the key housing when the polarity is being selectively adjusted.

4. The connector of claim 1, wherein the key housing defines a first slot adjacent the first slot of the first surface for receiving the first key structure.
5. The connector of claim 1, wherein the key housing defines a second slot adjacent the second slot of the second surface for receiving the second key structure.
6. The connector of claim 1, wherein, when the connector is in a configuration where the guide pins extend from the connector, the connector is in a male configuration, and wherein, when, the guide pins are removed, the connector is in a female configuration.
7. The connector of claim 1, wherein the key housing remains in an enclosed position relative to the first surface and the second surface when the polarity is being selectively adjusted.
8. A multi-fiber, fiber optic connector, the connector comprising:
 - a connector body configured for receiving a multi-fiber fiber optic cable; a first key structure on a first surface of the connector body;
 - a second key structure on a second surface of the connector body, the first and second key structures for setting a polarity of fibers within the connector, wherein the first surface and the second surface are on opposing sides of the connector body;
 - a housing enclosing a portion of the first surface of the connector body and the second surface of the connector body, the housing simultaneously retaining the first key structure and the second key structure; and
 - either one of guide pins or guide pin receiving holes for guiding a connection with a second connector,
 - wherein the first and second key structures are movable without opening the multi-fiber fiber optic connector between a first active position and a second retracted position, such that when the first key structure is in the first active position, the fibers are presented within the connector in a first polarity and when the second key structure is in the first active position, the

fibers are presented within the connector in a second polarity reversed from the first polarity.

9. The connector of claim 8, wherein a distal end of the first key structure is configured to be covered by the key housing when the first key structure is slid within the key housing.

10. The connector of claim 8, wherein a portion of the first key structure and a portion of the second key structure remains within the key housing when the polarity is being selectively adjusted.

11. The connector of claim 8, wherein the key housing defines a first slot adjacent a first slot of the first surface for receiving the first key structure.

12. The connector of claim 8, wherein the key housing defines a second slot adjacent a second slot of the second surface for receiving the second key structure.

13. The connector of claim 8, wherein, when the connector is in a configuration where the guide pins extend from the ferrule, the connector is in a male configuration, and wherein, when, the guide pins are removed from the ferrule, the connector is in a female configuration.

14. The connector of claim 8, wherein the key housing remains in an enclosed position relative to the first surface and the second surface when the polarity is being selectively adjusted.

15. A multi-fiber, fiber optic connector comprising: a connector body defining a first surface and a second surface;

a first key structure slidably positioned within a first slot defined on the first surface of the connector body;

a second key structure slidably positioned within a second slot defined on the second surface of the connector body;

a housing enclosing a portion of the first surface of the connector body and the second surface of the connector body,

wherein the first key structure is slideable relative to the first slot and the housing and configured to be received within the housing,

wherein the second key structure is slideable relative to the second slot and the housing and configured to be received within the housing, either one of guide pins or guide pin receiving holes for guiding a connection with a second connector,

wherein, in operation, a polarity of the fiber optic connector is selectively adjusted by ingressingly sliding the first key structure into the housing within the first slot and retracting the second key structure relative to the housing within the second slot such that the second key structure extends from the housing while the first key structure remains at least partially within the housing,

wherein a distal end of the first key structure is configured to be covered by the housing when the first key structure is slid within the housing and a portion of the first key structure and a portion of the second key structure remains within the housing when the polarity is being selectively adjusted.

16. The connector of claim 15, wherein, when the connector is in a configuration where the guide pins extend from the connector, the connector is in a male configuration, and wherein, when, the guidepins are removed, the connector is in a female configuration.

17. The connector of claim 15, wherein the housing remains in an enclosed position relative to the first surface and the second surface when the polarity is being selectively adjusted.

18. A method of changing the polarity of a fiber optic connector, the method comprising: selecting one of a first key structure and a second key structure for slideably positioning the first or second key structure into an active position,

wherein the first key structure is slidably positioned within a first slot defined on a first surface of a connector body;

wherein the second key structure is slidably positioned within a second slot defined on a second surface of the connector body;

wherein the first key structure and the second key structure are at least partially enclosed within a key housing, the key housing enclosing a portion of the first surface of the connector body and the second surface of the connector body, sliding the selected one of the first key structure and the second key structure towards a terminal end of the fiber optic connector into the active position;

retracting the other of the selected one of the first key structure and the second key structure into the key housing in a direction away from the terminal end of the fiber optic connector thereby changing a polarity of the fiber optic connector,

wherein the fiber optic connector includes either one of guide pins or guide pin receiving holes for guiding a connection with a second fiber optic connector.

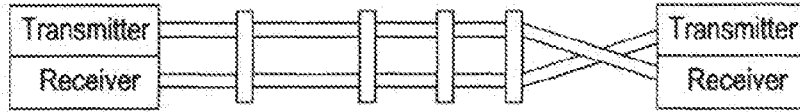
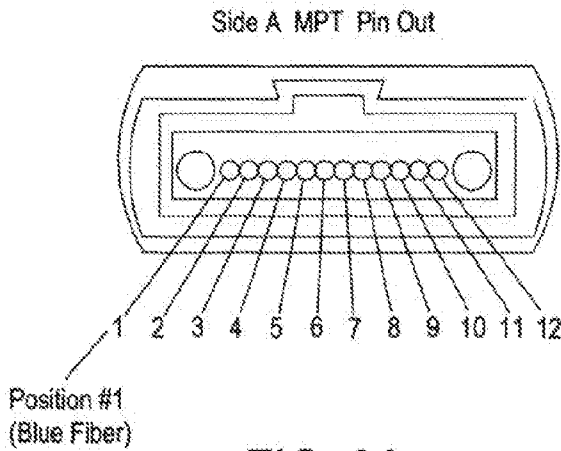

FIG. 1 PRIOR ART



FERRULE POSITION	FIBER CODE
1	BLUE
2	ORANGE
3	GREEN
4	BROWN
5	SLATE
6	WHITE
7	RED
8	BLACK
9	YELLOW
10	VIOLET
11	ROSE
12	AQUA

FIG. 2A PRIOR ART

METHOD A POLARITY

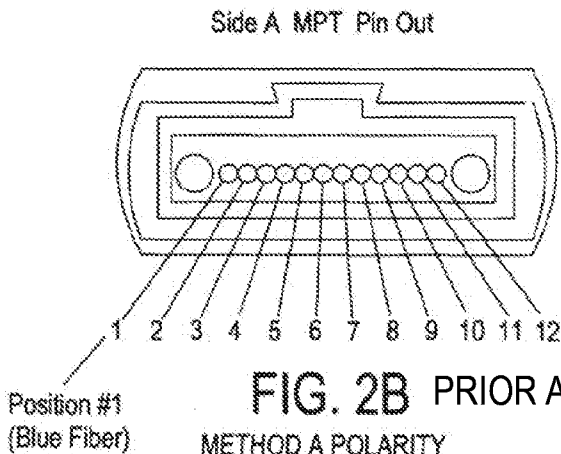

FERRULE POSITION	FIBER CODE
1	BLUE
2	ORANGE
3	GREEN
4	BROWN
5	SLATE
6	WHITE
7	RED
8	BLACK
9	YELLOW
10	VIOLET
11	ROSE
12	AQUA

FIG. 2B PRIOR ART

METHOD A POLARITY

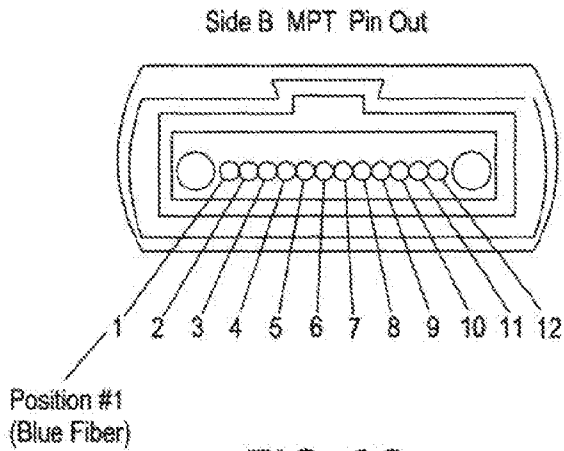

FERRULE POSITION	FIBER CODE
1	BLUE
2	ORANGE
3	GREEN
4	BROWN
5	SLATE
6	WHITE
7	RED
8	BLACK
9	YELLOW
10	VIOLET
11	ROSE
12	AQUA

FIG. 2C PRIOR ART
METHOD B POLARITY

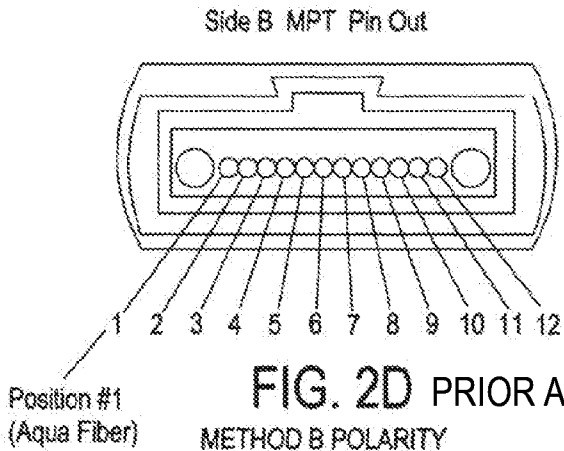

FERRULE POSITION	FIBER CODE
1	AQUA
2	ROSE
3	VIOLET
4	YELLOW
5	BLACK
6	RED
7	SLATE
8	WHITE
9	BROWN
10	GREEN
11	ORANGE
12	BLUE

FIG. 2D PRIOR ART
METHOD B POLARITY

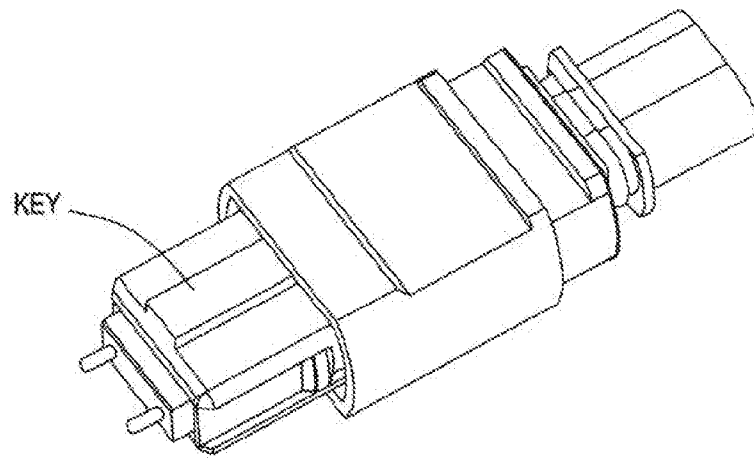

FIG. 3
(PRIOR ART)
MPO CONNECTOR

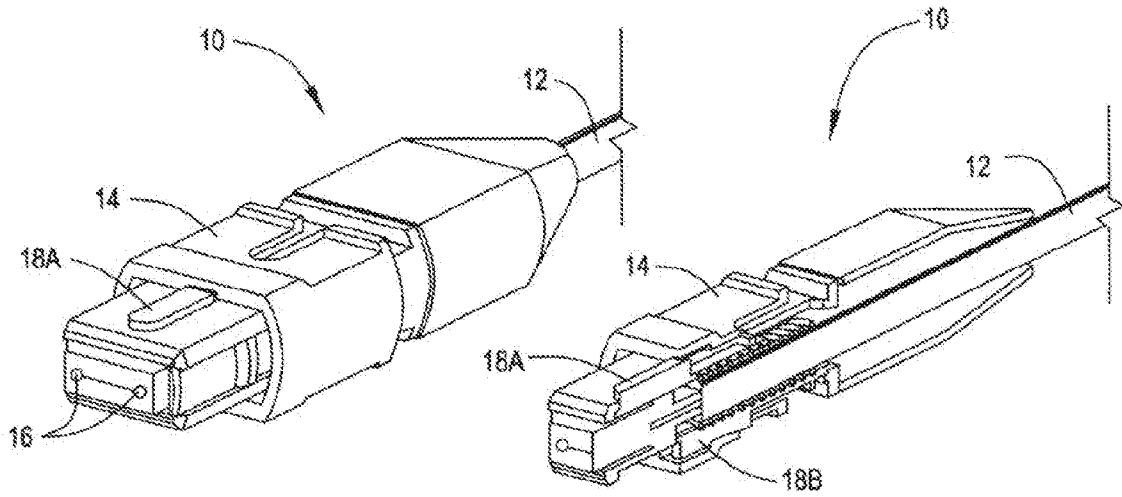

FIG. 4A

FIG. 4B

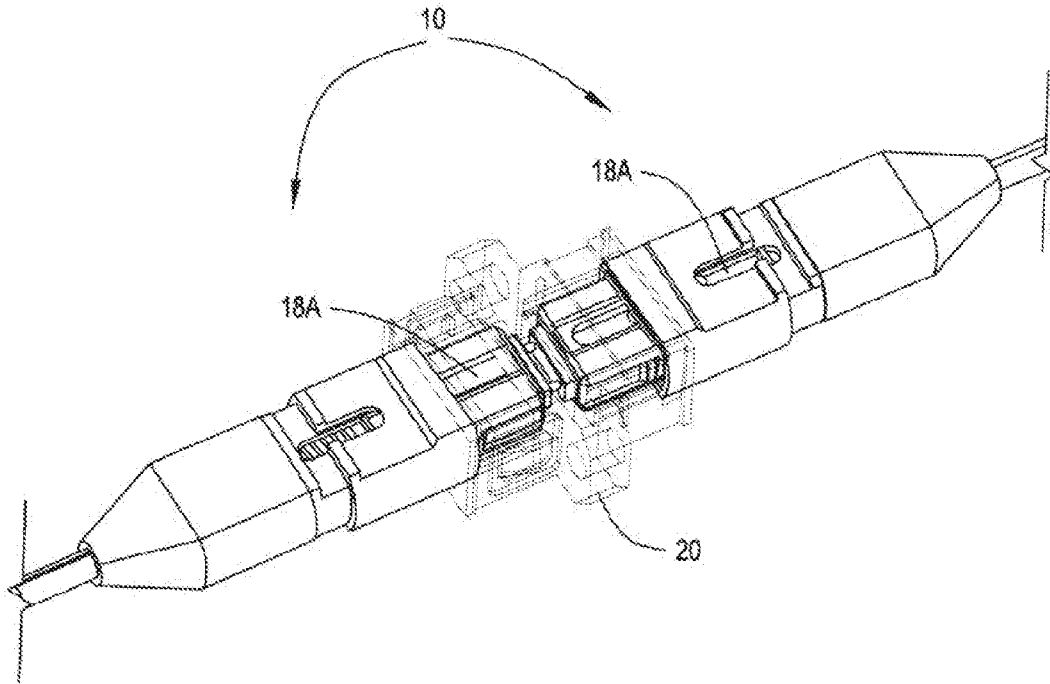

FIG. 5

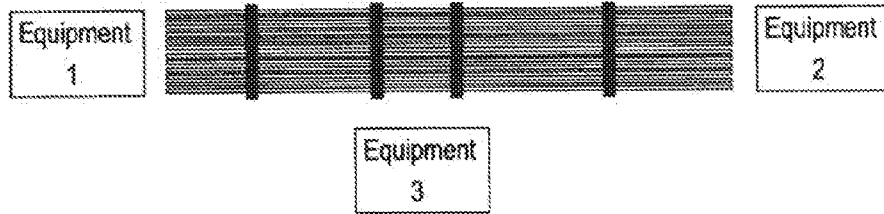

FIG. 6A

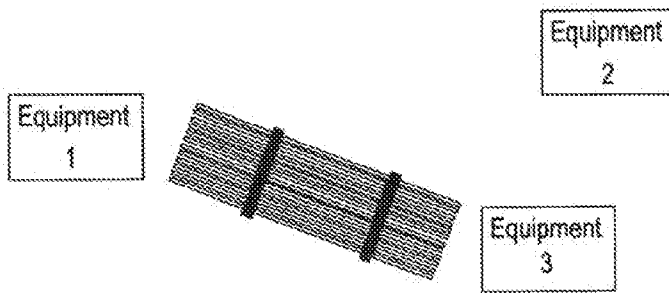

FIG. 6B

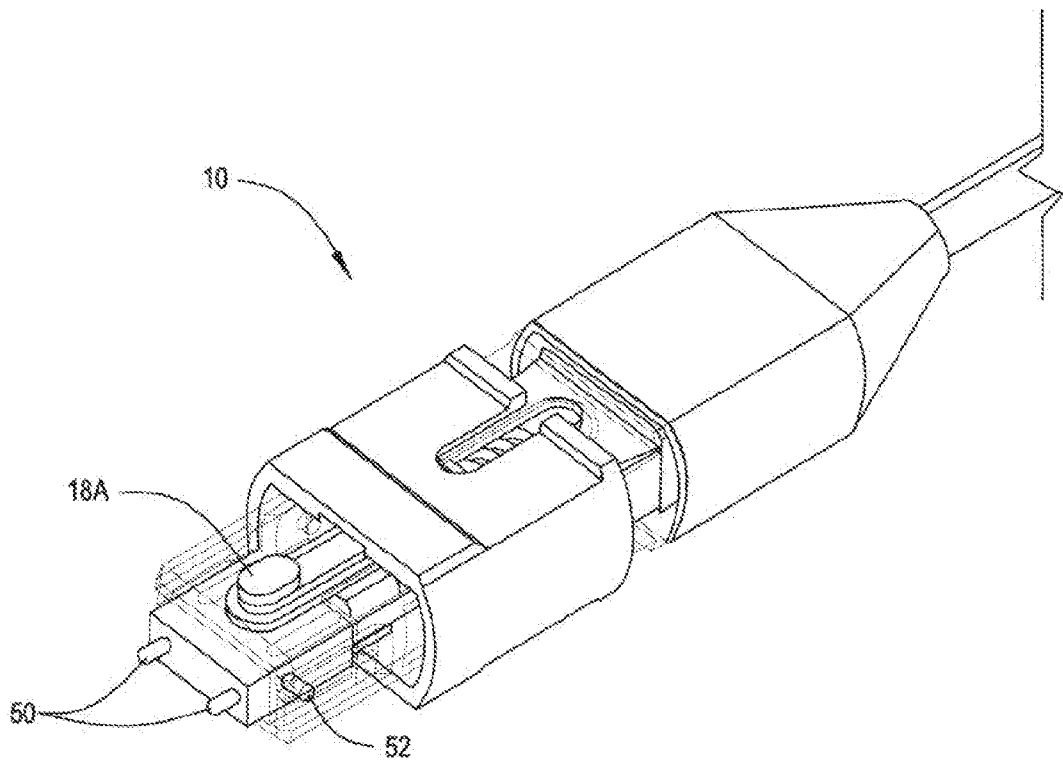

FIG. 7

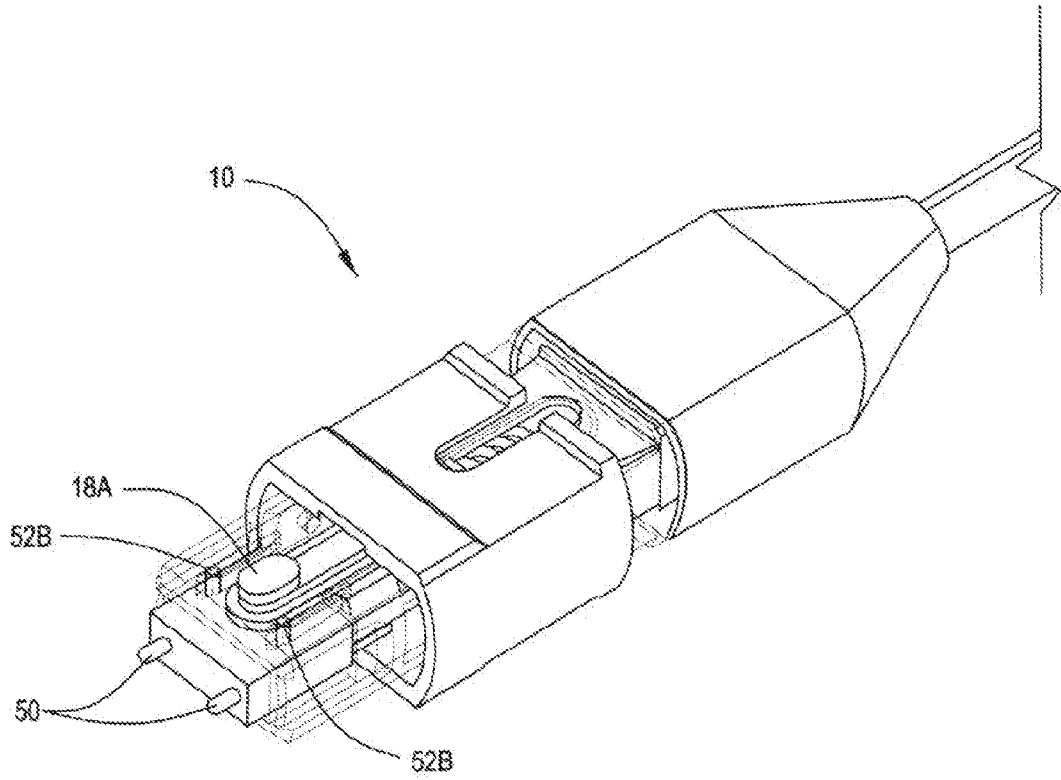

FIG. 8

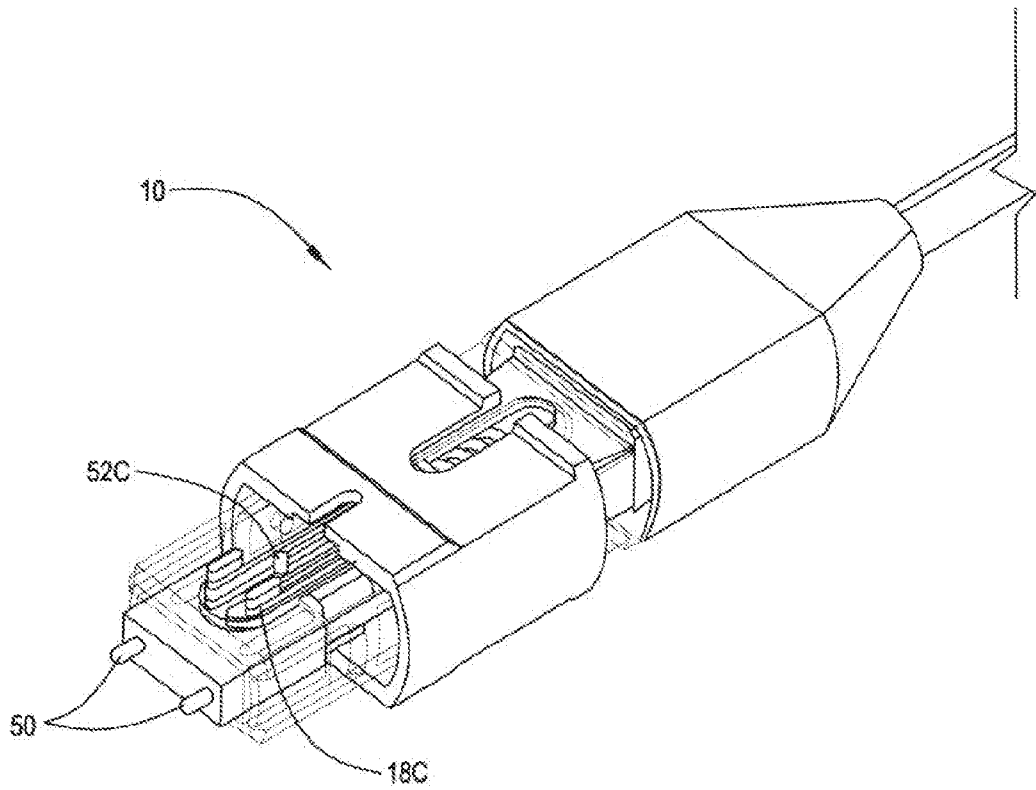

FIG. 9

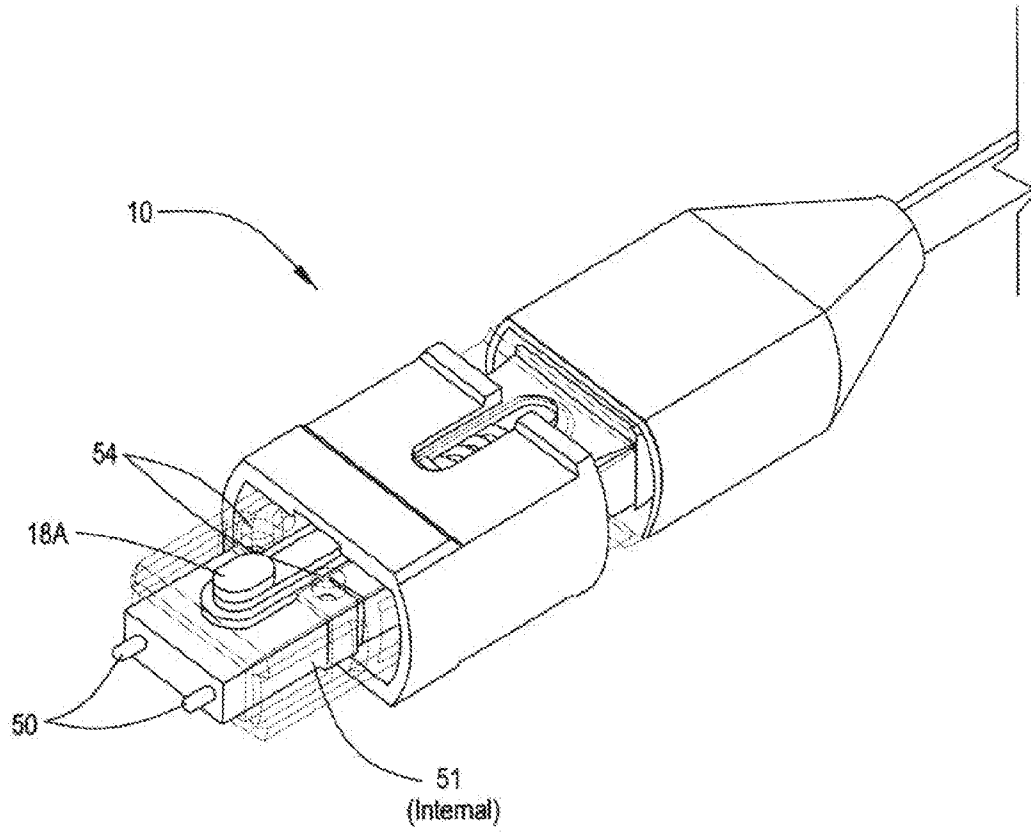

FIG. 10

