



(51) International Patent Classification:

A01F 25/22 (2006.01) F26B 21/02 (2006.01)
F26B 9/06 (2006.01) F26B 21/12 (2006.01)

(21) International Application Number:

PCT/US2019/032222

(22) International Filing Date:

14 May 2019 (14.05.2019)

(25) Filing Language:

English

(26) Publication Language:

English

(30) Priority Data:

62/671,122 14 May 2018 (14.05.2018) US
16/357,596 19 March 2019 (19.03.2019) US

(71) Applicant: **HABER TECHNOLOGIES LLC** [US/US];
2710 S. Loop Drive, Ames, Iowa 50010 (US).

(72) Inventor: **HARWEGER, Eric**; 2710 S. Loop Drive,
Ames, Iowa 50010 (US).

(74) Agent: **ZARLEY, Timothy J.** et al.; ZARLEY LAW
FIRM, P.L.C., Capital Square 400 Locust Street Suite 200,
Des Moines, Iowa 50309-2350 (US).

(81) Designated States (unless otherwise indicated, for every
kind of national protection available): AE, AG, AL, AM,
AO, AT, AU, AZ, BA, BB, BG, BH, BN, BR, BW, BY, BZ,
CA, CH, CL, CN, CO, CR, CU, CZ, DE, DJ, DK, DM, DO,

DZ, EC, EE, EG, ES, FI, GB, GD, GE, GH, GM, GT, HN,
HR, HU, ID, IL, IN, IR, IS, JO, JP, KE, KG, KH, KN, KP,
KR, KW, KZ, LA, LC, LK, LR, LS, LU, LY, MA, MD, ME,
MG, MK, MN, MW, MX, MY, MZ, NA, NG, NI, NO, NZ,
OM, PA, PE, PG, PH, PL, PT, QA, RO, RS, RU, RW, SA,
SC, SD, SE, SG, SK, SL, SM, ST, SV, SY, TH, TJ, TM, TN,
TR, TT, TZ, UA, UG, US, UZ, VC, VN, ZA, ZM, ZW.

(84) Designated States (unless otherwise indicated, for every
kind of regional protection available): ARIPO (BW, GH,
GM, KE, LR, LS, MW, MZ, NA, RW, SD, SL, ST, SZ, TZ,
UG, ZM, ZW), Eurasian (AM, AZ, BY, KG, KZ, RU, TJ,
TM), European (AL, AT, BE, BG, CH, CY, CZ, DE, DK,
EE, ES, FI, FR, GB, GR, HR, HU, IE, IS, IT, LT, LU, LV,
MC, MK, MT, NL, NO, PL, PT, RO, RS, SE, SI, SK, SM,
TR), OAPI (BF, BJ, CF, CG, CI, CM, GA, GN, GQ, GW,
KM, ML, MR, NE, SN, TD, TG).

Published:

— with international search report (Art. 21(3))

(54) Title: ASSEMBLY FOR SATURATING A MEDIUM WITH A FLUID

(57) Abstract: An assembly for saturating or aerating a medium
with fluid. At least one hollow cylinder having gates and vents em-
bedded within a grain mass. A target section of grain mass is iden-
tified and the gates and vents activated to provide influent flow to
the target section in both vertical and horizontal directions.

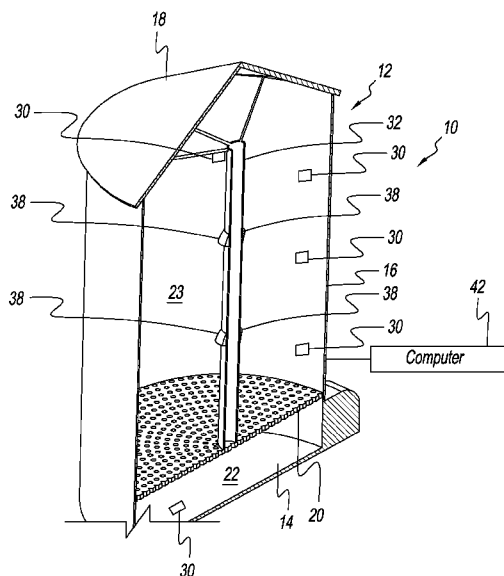

FIG. 1



TITLE ASSEMBLY FOR SATURATING A MEDIUM WITH A FLUID

BACKGROUND OF THE INVENTION

5 The present invention is directed to an assembly for saturating or aerating a medium with fluid. More particularly, the invention is directed to an assembly that selectively saturates cross sections of the medium within or without a container. The invention is used to saturate or coat any medium with fluid having or providing desired properties. As one example, the assembly can be used to saturate grain within a bin with air. This air may be artificially conditioned with heat, moisture, fumigants or any combination thereof. The natural air may
10 also be accepted to be sufficient as is.

Drying grain, aerating grain, or both is known in the art. Typically, grain is placed in a pile or in a bin atop a perforated bed or floor through which air, but not grain, may pass. A pressure gradient is created such that air is forced through the grain mass to push, pull, or both (“push”) a drying front through the grain. This process is passive in that the system is static; it
15 does not react to changing conditions within the grain mass. Nor does it change the air flow patterns within the system. The drying front is pushed through the entirety of the grain mass, including the bottom tiers to the top tiers, even after these tiers, or cross sections, of the grain mass have been conditioned.

As a result, the pressure gradient that needs to be overcome is large requiring large
20 amounts of energy to be put into the system. This energy typically comes in the form of mechanical energy, which creates the pressure gradient; and thermal energy, which facilitates the removal of moisture from grain. There also could be energy pertaining to air conditioned with fumigants. Not only is grain quality suboptimal, but often some grain is left too wet and others too dry. Accordingly, a need exists in the art for an assembly that addresses these
25 deficiencies.

An objective of the present invention is to provide a system that is adaptive to changing conditions within a grain mass.

Another objective of the present invention is to provide a system that is more energy efficient in conditioning a grain mass.

30 Another objective of the present invention is to provide a system that conditions a grain mass in less time.

Another objective of the present invention is to provide a system that more evenly conditions, preserves, or both, a grain mass.

35 These and other objectives will be apparent to those skilled in the art based on the following written description, drawings, and claims.

SUMMARY OF THE INVENTION

An assembly or system for saturating and/or aerating a medium with fluid includes at least one hollow cylinder with an inlet port and an exhaust port embedded within a medium, such as a grain mass. The cylinder has at least one vent associated with an opening in the cylinder to selectively seal the opening to either prevent or allow fluid to flow from the cylinder, through the opening, and into the grain mass.

The cylinder may also have one or more gates that selectively either allow or prevent fluid from flowing from an inlet port through the cylinder, and out the exhaust port. Through the combination of cylinders, vents, and gates, the system can dynamically create multiple flow patterns to direct fluid to targeted areas or sections within the grain mass. The flow patterns are horizontal, vertical, angular, transverse, two dimensional and three dimensional.

The system also includes a plurality of sensors that detect and transmit information about conditions in the grain mass and operating parameters of the system. The detected information is combined and compared with detected data from other systems in a centralized database.

The sensed data is also used by a control system having a computer. The control system processes the detected information and dynamically activates the vents and/or gates to create desired flow patterns.

BRIEF DESCRIPTION OF THE DRAWINGS

Fig. 1 is a side sectional perspective view of a saturating assembly;

Fig. 2 is a side sectional view of a saturating assembly;

Fig. 3 is a side sectional view of a vent;

Fig. 4 is a top plan perspective view of a gate;

Fig. 5 is a side sectional view of a vent assembly;

Fig. 6 is a side sectional view of a saturating assembly;

Fig. 7 is a side sectional view of a gate and a vent assembly;

Fig. 8 is a side sectional view of a fluid flow pattern;

Fig. 9 is a side sectional view of a fluid flow pattern;

Fig. 10 is a side sectional view of a fluid flow pattern;

Fig. 11 is a side sectional view of a fluid flow pattern; and

Fig. 12 is a side sectional view of a fluid flow pattern.

DETAILED DESCRIPTION OF THE PREFERRED EMBODIMENTS

Referring to the Figures, a system 10 for saturating a medium 11 with fluid includes at least one elongated hollow cylinder 32. The medium 11 is of any type, and for the purpose of explanation only, grain, such as corn to be dried, will be used as an example. The fluid is of any type including, but not limited to, liquid or gas. Saturating includes, but is not limited to, causing to process a desired property, impregnate or infuse and, in particular, referring to heat and mass transport phenomena.

The cylinder 32, having an inlet or bottom port 13 and an exhaust or top port 15 is embedded within a mass of grain 11. The grain mass 11 can be gathered in a pile that could be covered with a tarp or within a container 12. The container 12 is of any size, shape and structure including, but not limited to, a grain bin, a bulk bag, a hopper, a bucket, or the like. In one example, the container 12 includes a bottom 14, a side wall 16, and a top 18. The top 18 is of any type such as a roof, a wall, a lid, or the like.

Attached to and/or in communication with the cylinder 32 is a fan 24, a humidifier 26, and/or a heater 28, or other device that conditions the fluid to a desired quality. The cylinder 32 or cylinders have at least one, and preferably more, openings 34. The openings 34 are positioned along the length of the cylinders 32 in spaced relation and in a preferred embodiment have a screen 36 that covers the opening 34.

The container 12 may also have a divider 20 that separates the grain mass from the lower plenum 22. Positioned adjacent the inlet port 13, and the exhaust port 15, as well as within the grain mass 11, are a plurality of sensors. The sensors 30 detect information about the status or characteristics of the grain mass 11, such as temperature or humidity and operating parameters of the system 10. A baffle or flap 38 is connected to the exterior of the cylinder 32. The baffles are positioned above the openings 34 and extend outwardly and downwardly to deflect grain 11 away from the openings 34 while the grain mass 11 is placed around the cylinder 32.

Disposed within the cylinder 32 are a plurality of vents 40. The vents 40 are of any size, shape, and structure and include any device adapted to selectively seal the flow of fluid in the cylinder 32, either allowing or preventing the fluid to flow through the openings 34 and into the grain mass 11 or from the grain mass 11 into the openings 34 and into the cylinder 32.

In a similar embodiment, also disposed within the cylinders 32, adjacent to and above and/or below the vents 40, is at least one, and preferably more, gates 52. The vents 40, sensors 30, and gates 52 are connected to and controlled by a computer 42. The computer 42 has a processor, memory, monitor, input device, display, and network interface.

The gates 52 are of any size, shape, and structure. In one example, the gates 52 are disposed within a cylinder 32 having an inner surface 46. The gates, having outer surface 44,

span the width of the cylinder 32. To allow the transmission of pressurized air past the gate 52 there are a plurality of radially spaced barbs 48, each adapted to receive an air hose or tube 50.

5 The gate 52 has housing 54 with a cylindrical side wall 54, a bottom wall 56 with a central opening 58, and an open top 60. A pneumatic actuator 62 is mounted within the housing 54 by a plurality of cross-supports 63 and extends out of the open top 60. The actuator 62 has a spring-loaded piston 64 that is adapted to move in and out of a sleeve 66. One of the air tubes 50A is connected to the sleeve 66 to selectively provide pressurized air to the actuator 62 from a source of pressurized air 68. Attached to an end 70 of the piston 64 is a plug 72.
10 The plug 72 is positioned and sized to selectively fill and seal the opening 58 in the bottom wall 56 of the housing of gate 52 to seal the opening 58.

Positioned above and/or below each gate 52, within cylinder 32, is a vent assembly 74. The vent assembly 74 is of any size, shape, and structure. In the example shown the vent assembly 74 has a plurality of flaps 76 connected to a central connector 78 by links 80. The
15 flaps 76 have an inner surface 82 and a top edge 84. The links 80 are pivotally connected at a first end 86 to the central connector 78 and pivotally connected at a second end 88 to the inner surface 82 of the flap 76.

The cylinder 32, adjacent the flaps 76, has an outwardly extending cuff 90. The cuff 90 has a first or top wall 92 that extends outwardly in relation to a vertical axis of the cylinder 32
20 to a transition point 94, and a second, or bottom wall 96 that extends from the transition point 94 back toward the vertical axis of the cylinder 32 to provide a generally triangular cross-section.

The first wall 92 is angled from the cylinder 32 to the transition point 94 to prevent grain from sitting on the wall 92. The cylinder 32 has a plurality of openings 98 that align with the
25 flaps 76. The second wall 96 angles downwardly from the transition point 94 to the cylinder 32, preferably at the angle of repose, and is perforated.

The central connector 78 is connected to a second pneumatic actuator 100. The second pneumatic actuator 100 is positioned above the central connector 78 and mounted to the inner surface 44 of the cylinder 32. Like the first actuator 62, the second actuator 100 has
30 a spring-loaded piston 64 that is adapted to move in and out of a sleeve 66. One of the air tubes 50B is connected to the sleeve 66 to selectively provide pressurized air to the sleeve 66. The central connector 78 is connected to an end 70 of the piston 64.

The gates 52 and vent assemblies 74 are vertically spaced within the cylinders 32 and define horizontal tiers 102 within the container 12. The vertical cylinders 32 define vertical
35 regions 104 between the cylinders 32 and between the cylinders and an outer side wall 106 of

the container 12. The combination of tiers 102 and regions 104 define sections 108 within the grain mass.

5 In operation, the sensors 30 detect information about the grain mass 11 and transmits this information to the computer 42 where the information is stored. In one embodiment the information is sent to a cloud based storage where the information is combined with information from other saturation systems. The combined information is processed and analyzed and can be used by each system to improve the saturation process and efficiency as well as artificial intelligence for each system.

10 The sensed information is also processed and analyzed to dynamically determine and create a flow pattern through the grain mass. As an example, the sensors 30 send information regarding the status and characteristics of the grain mass 11, such as temperature and humidity, to the computer 42. The computer 42 uses this information to determine conditions of the grain mass 11, such as moisture content, and operating parameters of the system 10, such as flow rate. The computer 42 compares the determined condition and/or parameter with a predetermined condition and/or parameters that is stored within the computer. Stored information may include, but is not limited to, time parameters, historical data, external data from other sources including information from other saturating systems, user inputs, weather conditions and any combinations thereof.

20 Based upon the comparison, the computer activates various vents 40 and/or gates to open or close to direct the flow pattern of the fluid through the medium in an efficient manner. The vents 40 and gates 52 are activated electrically, hydraulically, mechanically, pneumatically or any combination thereof. In particular, software and processor also determines target section 110 which is the section 108 to be saturated such as the section with the highest moisture content. Based upon the identified target section 110 the computer 42, through electrical signal or the selective release of pressurized air from the source of pressurized air 25 68 activates selected gates 52 and vent assemblies 74.

30 The number of flow patterns is unlimited based upon the various combination of cylinders 32, vents 40, and gates 52 and include both two dimensional flow patterns such as a triangle, and three dimensional flow patterns such as a pyramid with n-number of legs. Any conceivable shape of flow pattern can be created.

In one example, using one cylinder 32 a first vent 40A or 74A (used interchangeably) is positioned below a second vent 74B in spaced relation. With both vents open, fluid will flow through the air cylinder 32 from the inlet port 13 to the exhaust port 15. With vent 74A open, some fluid will flow out of cylinder 32 through vent 74A and into the grain mass 11. Since vent

74B is also open, the fluid in the grain mass 11 will flow through vent 74B into cylinder 32 and to exhaust port 15.

To enhance this flow pattern, gates 52A and 52B are positioned adjacent vents 74A and 74B. With gate 52A closed, all fluid is forced through vent 74A into the grain mass 11.

5 With gate 52B open, fluid is drawn back through vent 74B, into cylinder 32, and to exhaust port 15. To obtain an additional, more horizontal or transverse flow pattern, perforated tubes 17 are positioned in vertical spaced relation to the cylinder 32. As a result, some fluid flows from vent 74A across the grain mass 11 to the perforated tube 17.

10 In another example, using multiple cylinders 32, the vents 74 and gates 52 are activated to a target section between the cylinders 32.

For example, as shown in Fig. 6, the tiers 102 are represented by T0, T1, T2, and T3, while the regions 104 are represented by A, B, C. The target section 110 is positioned in the section where tier T1 crosses region B.

15 The assembly has two cylinders 32 shown as X and Y, with each cylinder having vertically spaced gates 52A, 52B, 52C, 52D, 52E and 52F, with each gate having a vent assembly 74A, 74B, 74C, 74D, 74E, and 74F positioned adjacent and below each gate respectively.

To direct influent, air that has yet to dry the grain mass, to the target section, in the example shown, gates 52A, 52E, and 52F are opened while the remaining gates stay in a normal closed, spring-biased, position. At the same time, vent assemblies 74B and 74E are opened while the remaining vent assemblies remain in a normal closed, spring-biased, position. As a result, an air flow path is created such that influent flows from the fan 24 through heater 28 or other conditioning devices and into cylinder 32X and past open gate 52A and closed vent assembly 74A to closed gate 52B and open vent assembly 74B.

25 The influent is then drawn horizontally in a straight line into the target section 110 through open vent assembly 74B toward open vent assembly 74E. The effluent, air that has dried the grain mass, flows into cylinder 32Y through vent assembly 74E and past open gate 52E and 52F and closed vent assembly 74F and is discharged from cylinder 32Y. Flow into cylinder 32Y from the inlet port 13 is restricted by closed gate 52D.

30 The flow pattern may be further expanded by opening more vents 74 in cylinder 32X, cylinder 32Y, or both. For example, in addition to vent 74B and gates 52E and 52E being open, by opening vent 74A, the flow pattern changes from a line to a triangle. More specifically, some fluid will flow from vent 74A at an angle to vent 74E and some fluid will flow from vent 74B straight across to vent 74E.

A modified flow pattern would be created by closing gate 52A and opening gates 52B and 52C. As a result some fluid would flow from vent 74A to 74B and some would flow from vent 74A to vent 74E. After reaching vents 74B and 74E, the effluent would be unrestricted to exit the system through exhaust port 15.

5 Another modified flow pattern would be created by closing vent 74A and opening vents 74B, 74D, and 74E while opening gates 52A and 52E and closing gates 52B and 52D. As a result, some fluid would flow from vent 74D toward both vents 74B and 74E but only through vent 74E and fluid would flow from vent 74B both toward and through 74E.

10 In yet another modified flow pattern vents 74A, 74B, 74E and 74F are open as are gates 52A, 52E, and 52F. As a result fluid flows at an angle from vent 74A to vent 74E and 74B to 74F forming a polygon shaped flow pattern.

15 Any flow pattern could be adjusted to avoid short circuiting a target section 110. This is done by lowering the flow through any vent by partially opening the vent or adjusting the air flow in one cylinder relative to the other. Also, the height of the vents 74 and gates 52 are changed to modify flow patterns. Finally, conduits can be connected to and be in communication with multiple cylinders particularly at the input port.

The modification of flow patterns is useful for a number of reasons. The ability to change the flow pattern to adapt to changing conditions within the grain mass as detected by the sensors or as otherwise ascertained by historical data, outside data or human input. Artificially creating a smaller grain depth and/or horizontal flow profile diminishes the energy required to drive fluid through the grain mass. Controlling the height and direction of flow patterns allows the drying front to be effectively and artificially moved through the grain mass, causing the time to dry the grain to be dependent on a controlled system and not equilibrium. Varying flow through different sections of the grain mass allows the sections to be dried to a precise predetermined level, no more, no less, throughout the entire grain mass.

25 Data from other grain masses may be used also to check for errors in the system, as well as other reasons. For example, the data may be used to preemptively aerate certain sections of the grain mass based upon data from statistically similar grain masses which appear to be at risk of spoilage. The data may also be used to replace detected information from a failed sensor.

30 The computer 42 modifies the flow pattern when target sections obtain desired conditions. Moisture content, number of hotspots and other relevant data is collected over the course of a storage season to create new protocols and a score sheet of the value of the grain mass. This might be done to mathematically estimate the theoretical dry matter loss of the grain in the mass. This could be done over the course of a few storage seasons and compared

to the actual value of the grain as sold in the market to improve the accuracy of the estimate. This could be done in absolute terms as it relates to the specific quality of the grain in that mass, or as in relative terms comparing it to the grain in other grain masses, or both. The data used to provide a relative estimate of the value of the grain could also be used to provide
5 research on the grain market. The data is also used by the computer 42 to develop machine learning through artificial intelligence. The computer, based on both internal and external data will anticipate and create flow patterns that protect the grain mass, reduce drying time, and reduce energy consumption.

10 Accordingly, an assembly for saturating a medium with fluid which includes an assembly for drying a grain mass with influent has been disclosed that, at the very least, meets the stated objectives.

What is Claimed Is:

1. Assembly for saturating a medium with a fluid, comprising: at least one hollow cylinder having an input port and an output port embedded within a medium; and at least one vent assembly that selectively opens and closes to seal an opening in the at least one hollow cylinder.
5
2. The assembly of claim 1 wherein at least one gate is disposed within the at least one hollow cylinder to selectively restrict fluid flow through the at least one hollow cylinder.
10
3. The assembly of claim 1 wherein the at least one vent assembly is pneumatic.
4. The assembly of claim 1 further comprising a plurality of sensors disposed within the medium adapted to determine the conditions of a medium.
15
5. The assembly of claim 1 wherein one or more fluid conditioning devices are in communication with the hollow cylinder.
6. The assembly of claim 1 wherein at least two hollow cylinders conduct fluid and allow for the horizontal transfer of fluids through the medium.
20
7. The assembly of claim 1 wherein the at least two hollow cylinders divide the medium into vertical regions.
8. The assembly of claim 1 wherein the at least one gate divides the medium into horizontal tiers.
25
9. The assembly of claim 1 wherein the medium has sections defined by horizontal tiers and vertical regions.
30
10. The assembly of claim 9 wherein at least one sensor associated with each section transmits information about a medium in the sections to a computer which calculates the condition of the medium in the sections.
- 35 11. The assembly of claim 10 wherein the computer determines a target section.

12. The assembly of claim 11 wherein the computer activates the at least one vent assembly and at least one gate to create a flow path where influent flows to and through the target section and effluent flows from the target section to discharge.
- 5 13. The assembly of claim 10 wherein at least two cylinders are embedded in the medium, each with at least one gate and one vent assembly, which allow for influent air to pass through one cylinder, through the target section, and discharge from the medium through the other cylinder and allowing for horizontal air flow.
- 10 14. The assembly of claim 10 wherein the at least one cylinder has more than one vent assembly with at least one gate assembly in between the vent assemblies, allowing for the influent air to pass through the cylinder up until the at least one gate, out a first vent assembly, through the target section, and back into the cylinder and allowing for vertical bypassing of sections of the medium.
- 15 15. The assembly of claim 11 wherein the computer keeps track of the conditions in the target sections and the whole of the medium and is able to estimate the overall quality and value of the medium.
- 20 16. The assembly of claim 15 wherein multiple assemblies communicate with one another and are able to estimate the value of each medium relative to one another.
- 25 17. The assembly of claim 16 wherein multiple assemblies are able to complement one another via statistical analysis to determine errors and improve individual assembly performance.

1/11

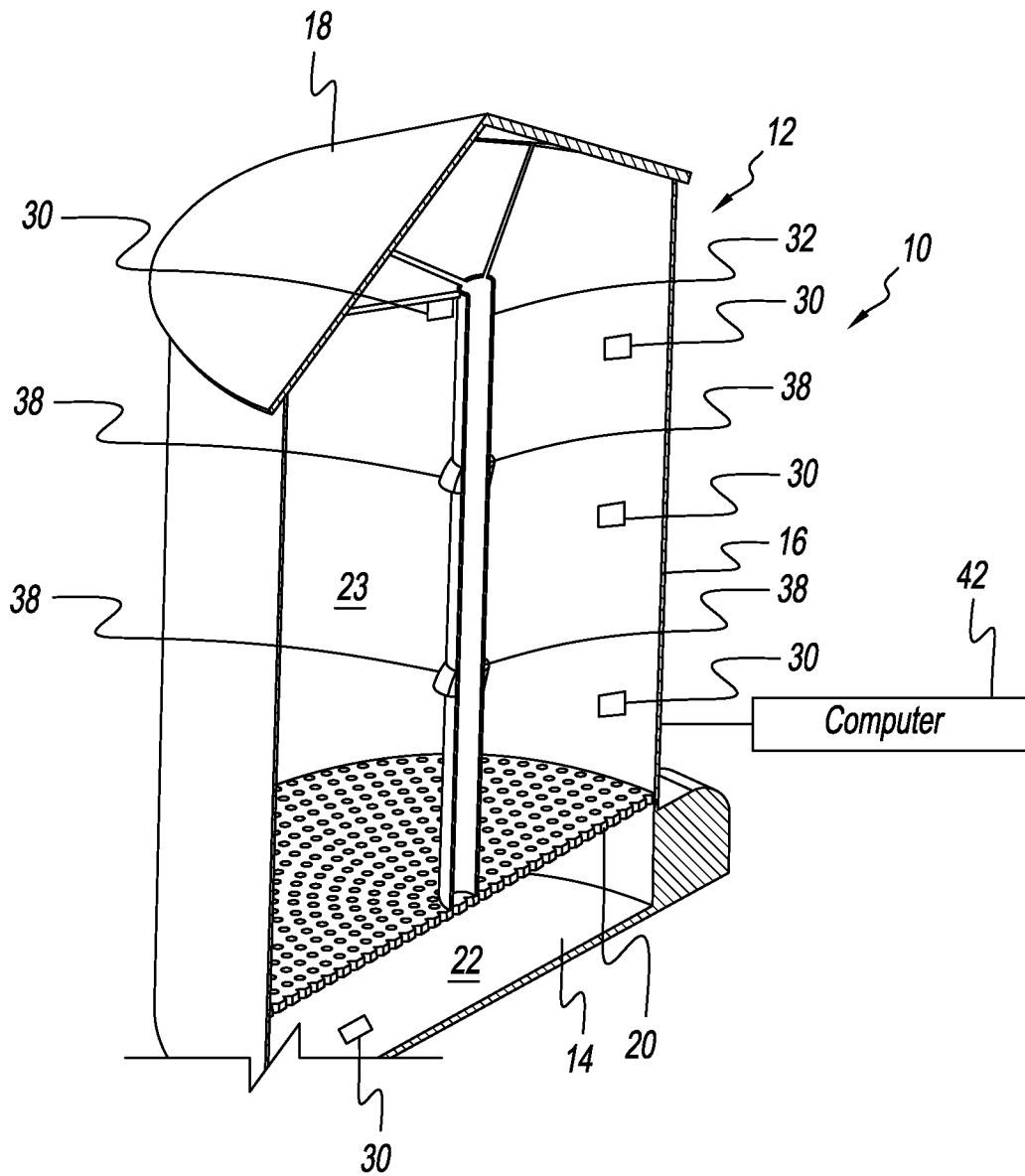

FIG. 1

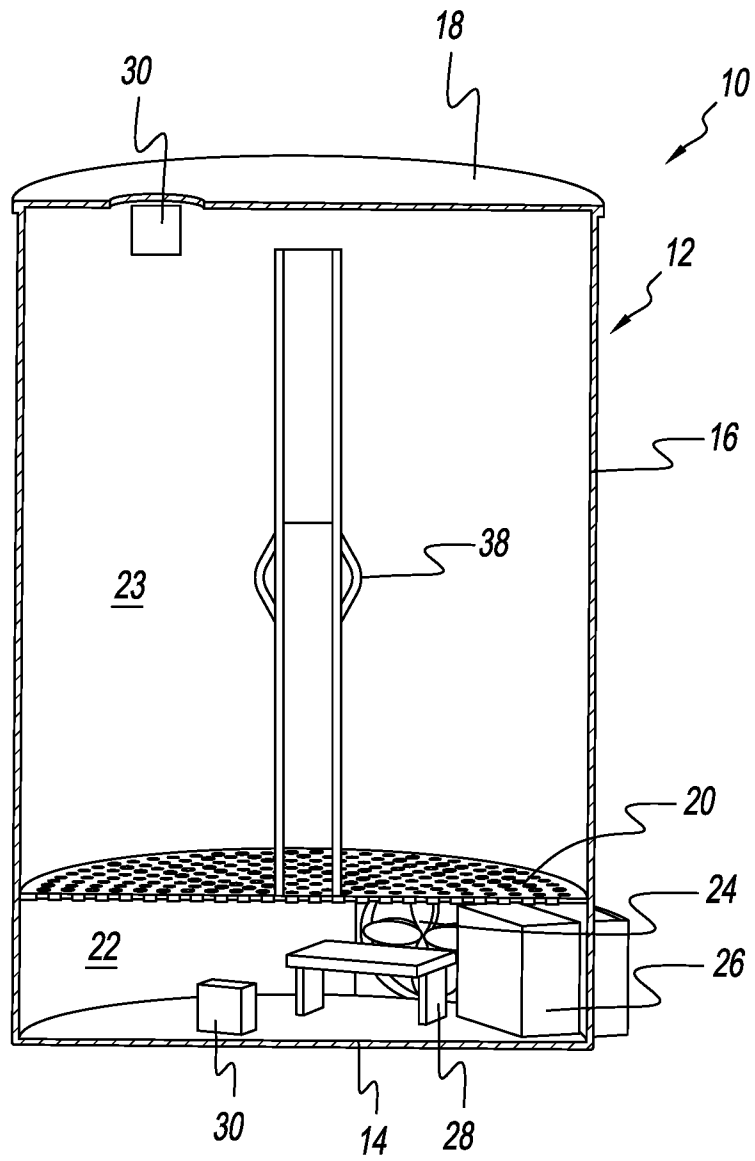

FIG. 2

3/11

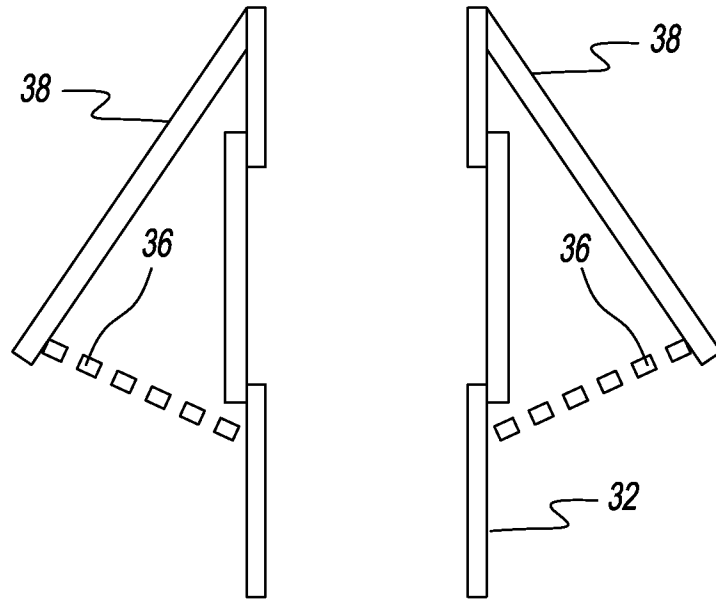

FIG. 3

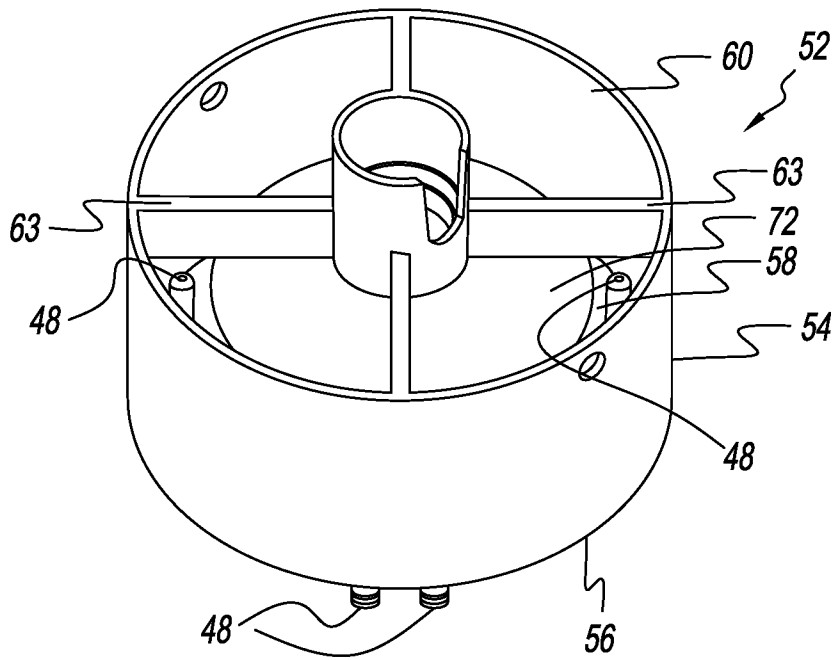

FIG. 4

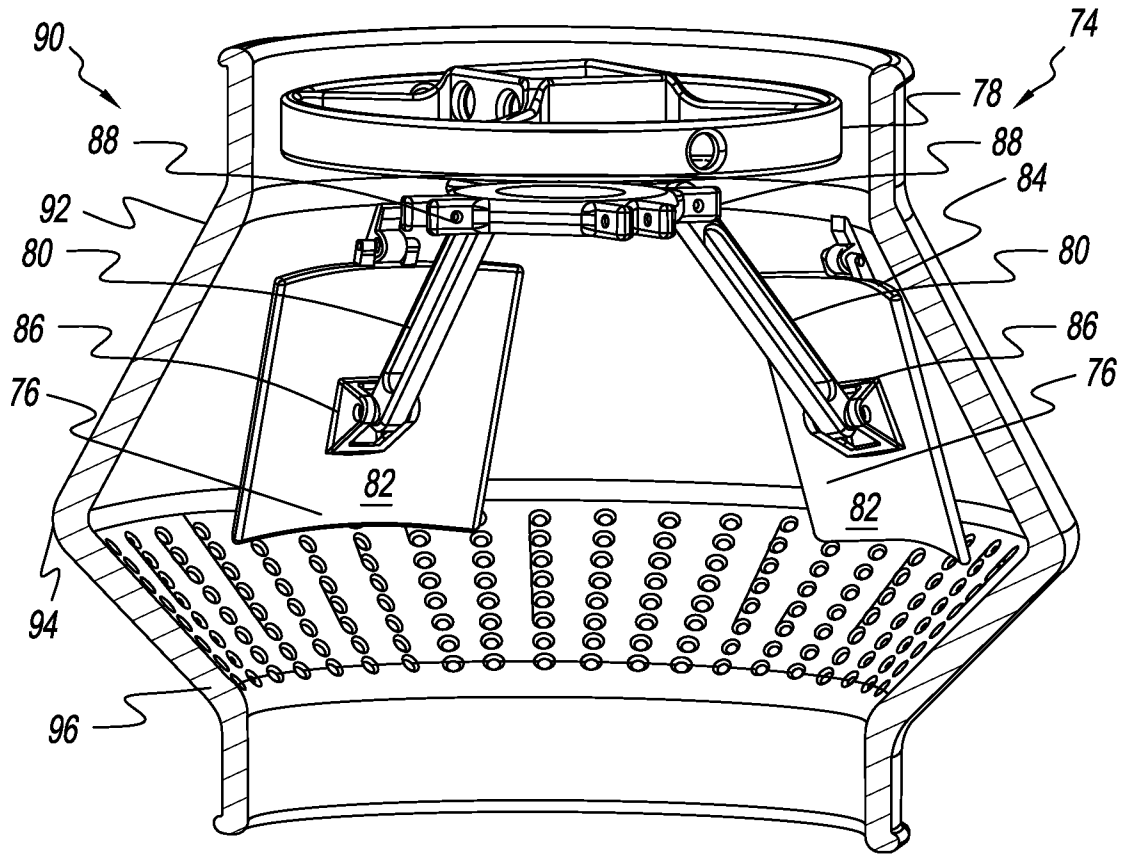

FIG. 5

5/11

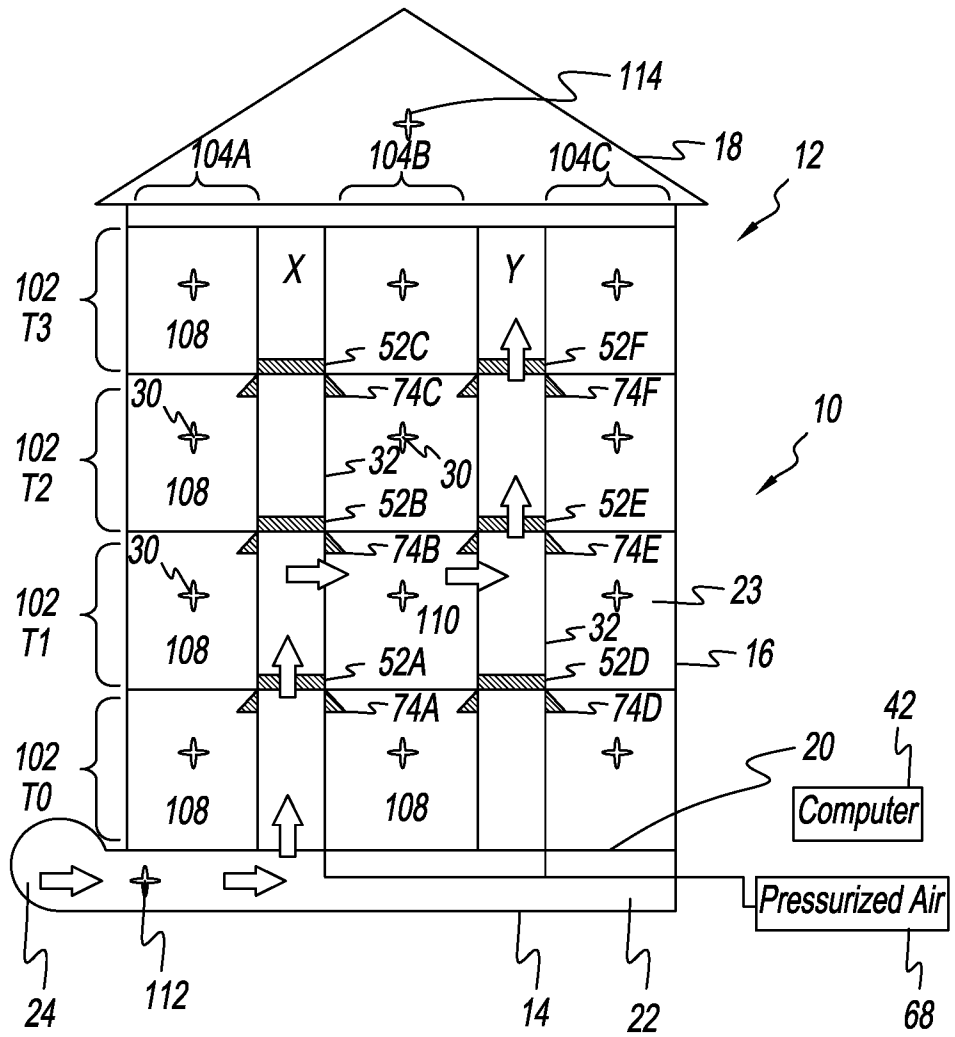

FIG. 6

6/11

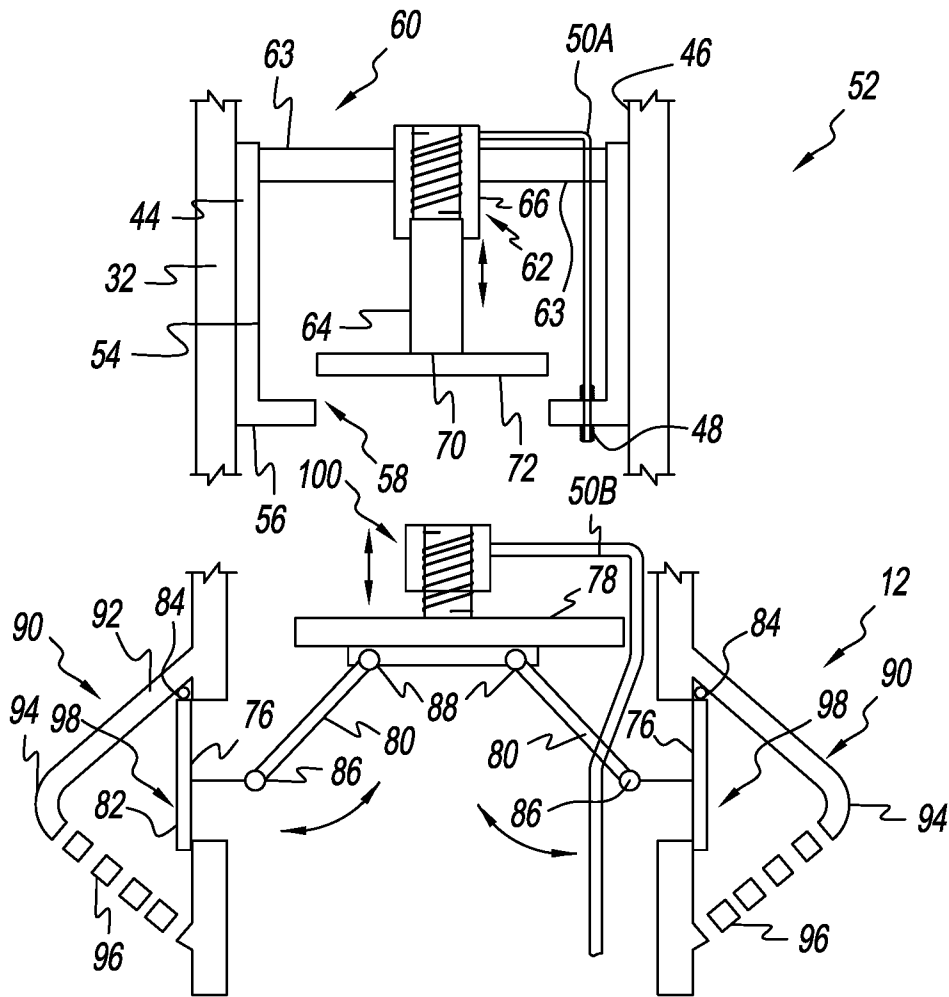

FIG. 7

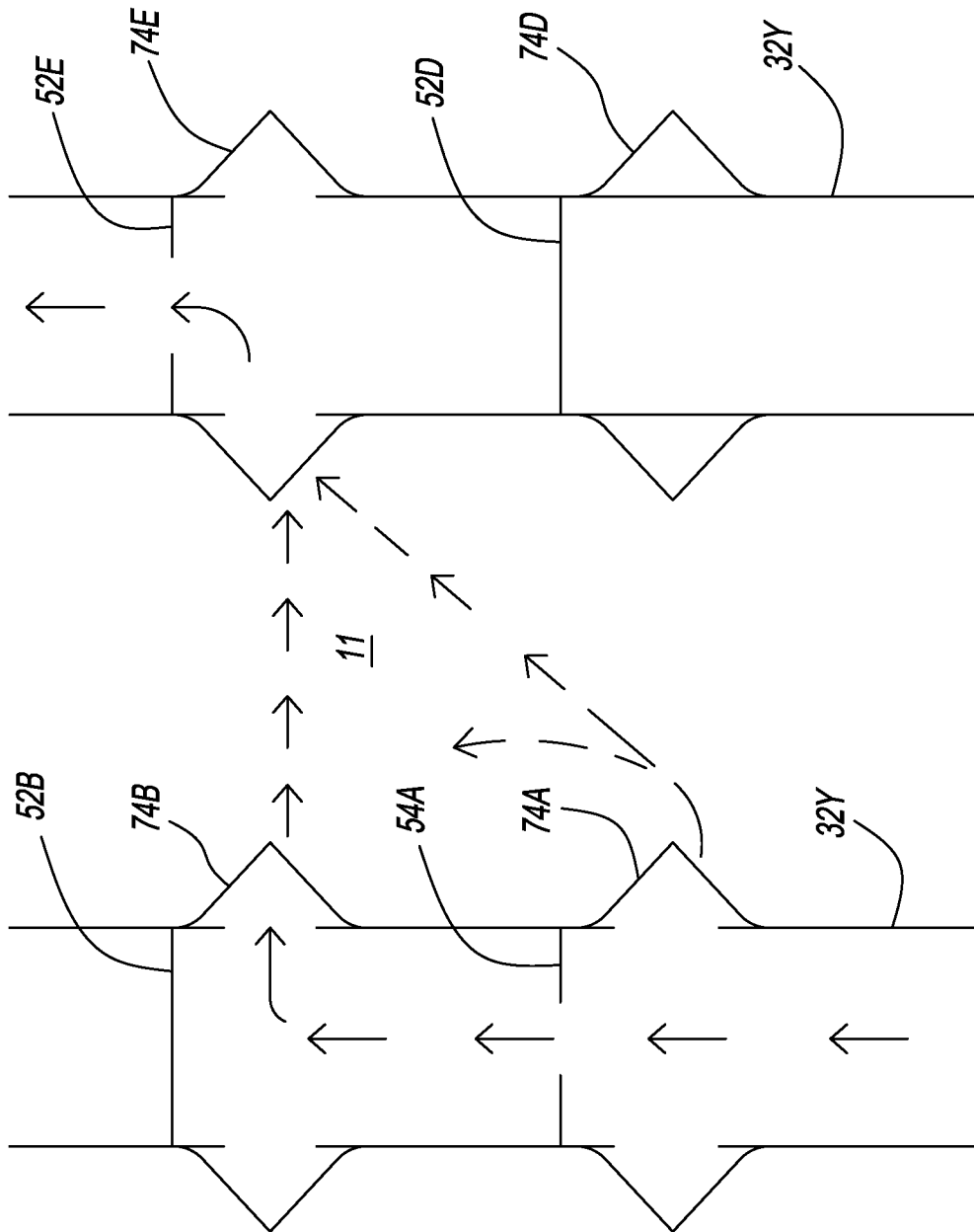

FIG. 9

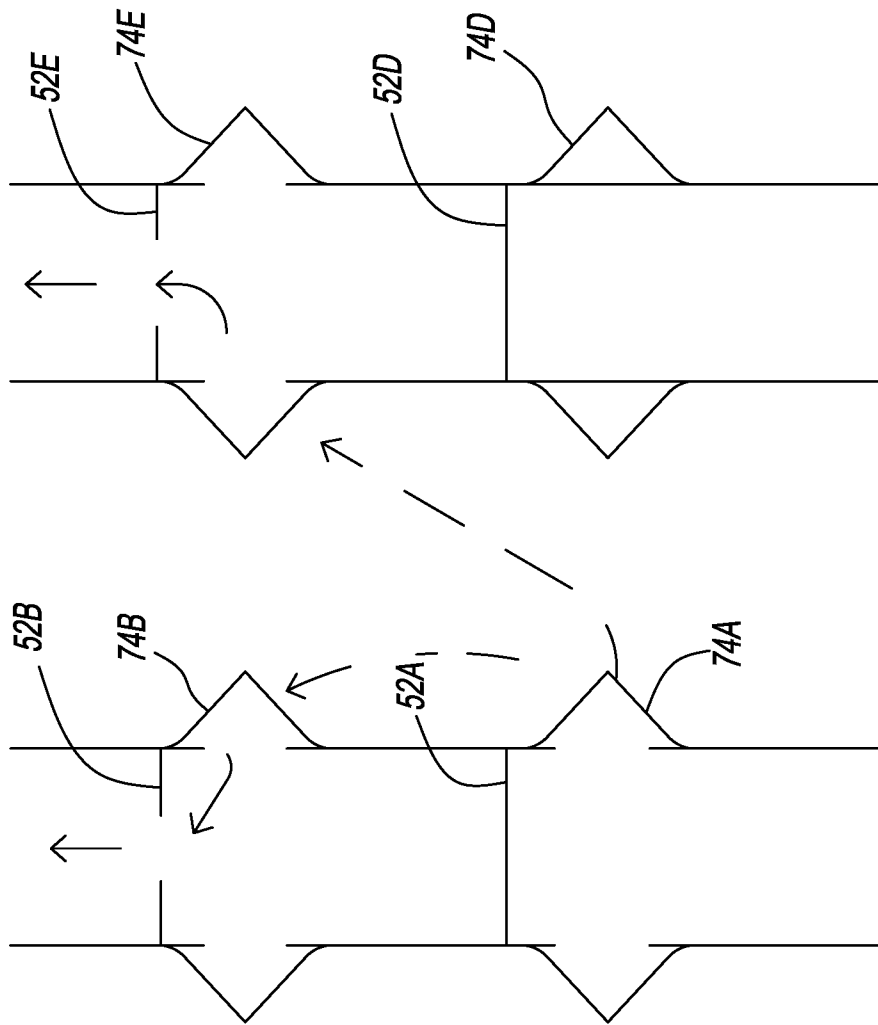

FIG. 10

10/11

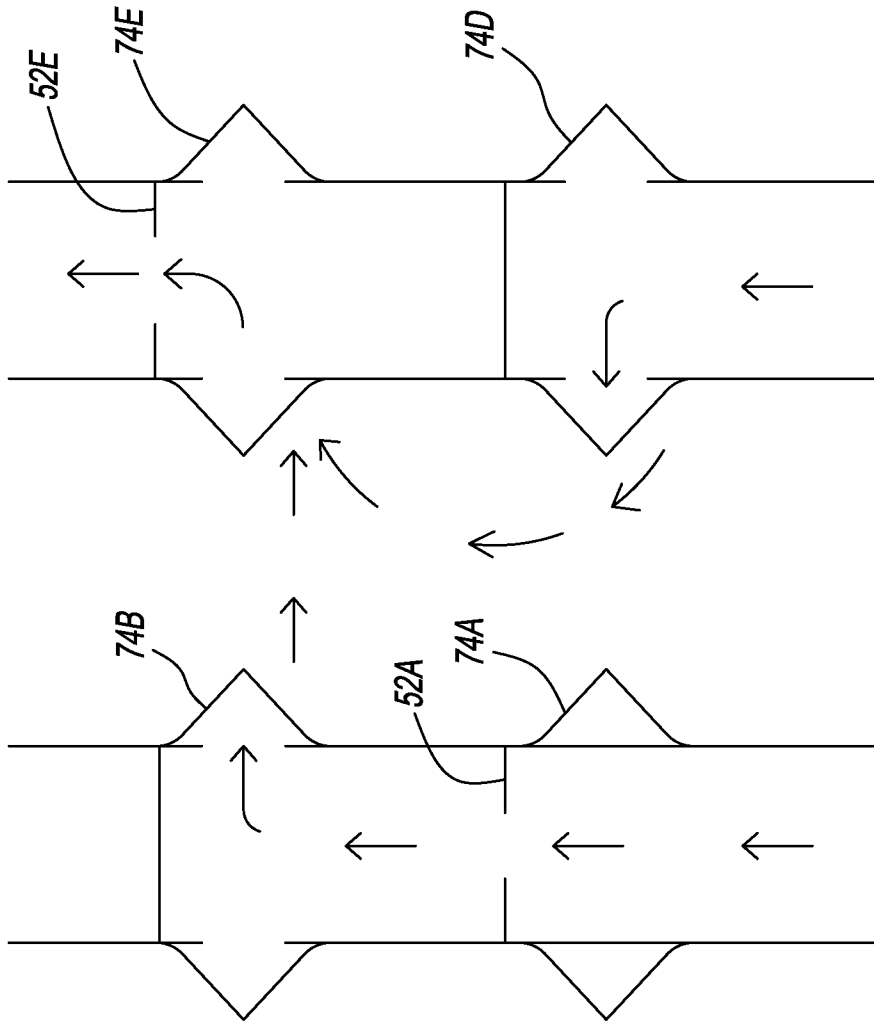

FIG. 11

11/11

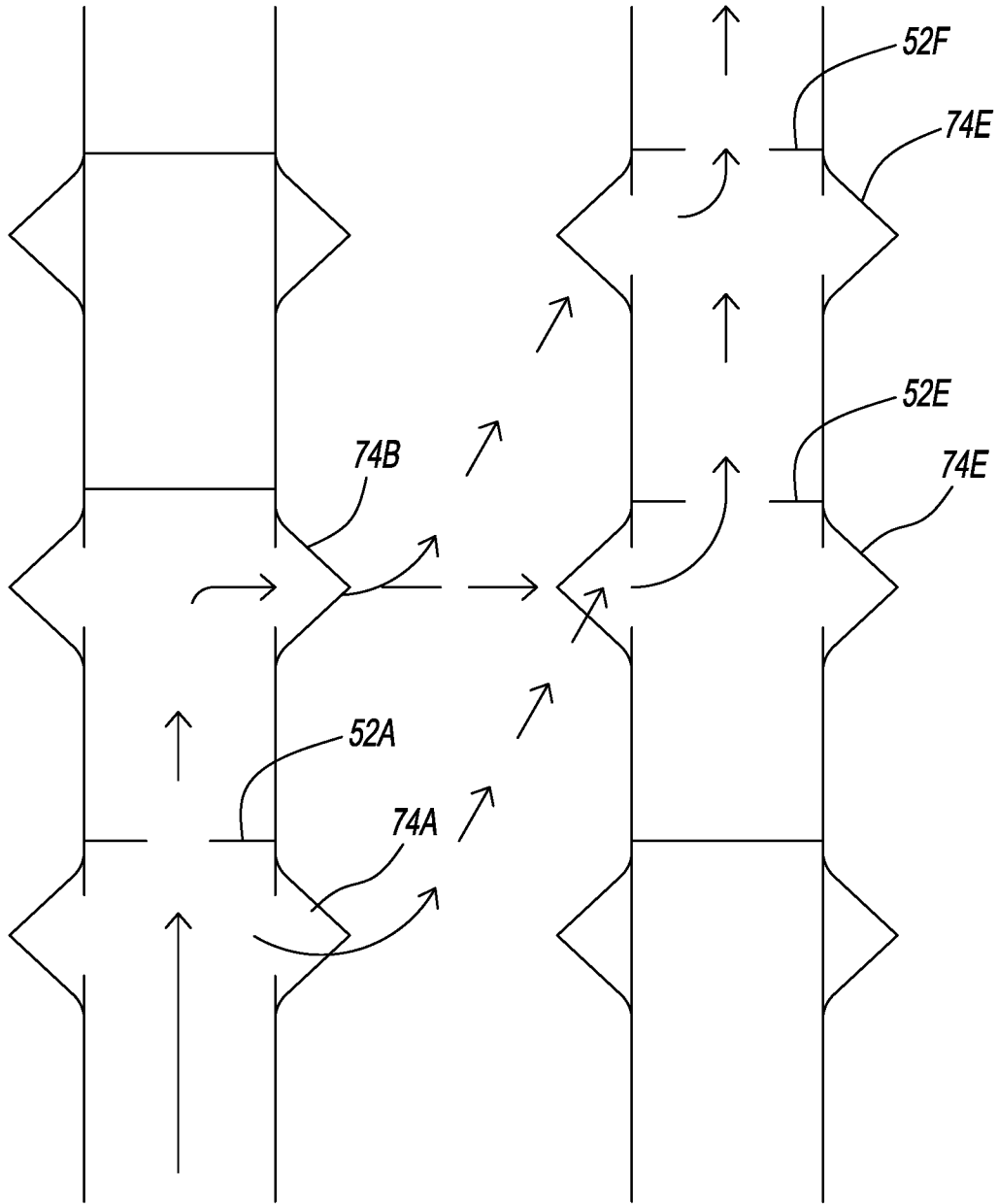

FIG. 12

INTERNATIONAL SEARCH REPORT

International application No.

PCT/US 19/32222

A. CLASSIFICATION OF SUBJECT MATTER
 IPC(8) - A01F 25/22, F26B 9/06, F26B 21/02, F26B 21/12 (2019.01)
 CPC - A01F 25/22, F26B 9/06, F26B 21/02, F26B 21/12, F26B 2200/06, F26B 21/028, F26B 21/022, F26B 9/063

According to International Patent Classification (IPC) or to both national classification and IPC

B. FIELDS SEARCHED

Minimum documentation searched (classification system followed by classification symbols)

See Search History Document

Documentation searched other than minimum documentation to the extent that such documents are included in the fields searched

See Search History Document

Electronic data base consulted during the international search (name of data base and, where practicable, search terms used)

See Search History Document

C. DOCUMENTS CONSIDERED TO BE RELEVANT

Category*	Citation of document, with indication, where appropriate, of the relevant passages	Relevant to claim No.
X --- Y --- A	CN 204762297 U (Univ Nanjing Finance & Eco) 18 November 2015 (18.11.2015) Entire document especially page 5 and figs. 1-3, 5-7	1-2, 5-7, 9 ----- 3-4, 10-12, 15 ----- 8, 13-14, 16, 17
Y	CN 2398232 Y (Zhengchang Group Corp Jiangsu) 27 September 2000 (27.09.2000) Entire document especially pages 3-4 and fig. 1	3
Y --- A	US 2014/0046611 A1 (Bloemendaal et al.) 13 February 2014 (13.02.2014) Entire document especially para [0030]-[0032], [0038]-[0039], [0064], [0075], [0078], [0081] and figs. 1-3 and 12	4, 10-12, 15 ----- 13, 14, 16, 17
A	US 2016/0050948 A1 (Robbins et al.) 21 April 2016 (21.04.2016) Entire document	1-17
A	US 2011/0252663 A1 (Ralph et al.) 20 October 2011 (20.10.2011) Entire document	1-17
A	US 4,885,985 A (Pollock) 12 December 1989 (12.12.1989) Entire document	1-17
A	WO 2017/060823 A1 (Bresler) 13 April 2017 (13.04.2017) Entire document	1-17
A	US 2012/0066924 A1 (Ando et al.) 22 March 2012 (22.03.2012) Entire document	1-17
A	US 2014/0250718 A1 (Fujitomo) 11 September 2014 (11.09.2014) Entire document	1-17
A	US 2018/0058759 A1 (A1Engineering) 1 March 2018 (01.03.2018) Entire document	1-17

Further documents are listed in the continuation of Box C. See patent family annex.

* Special categories of cited documents:	"T" later document published after the international filing date or priority date and not in conflict with the application but cited to understand the principle or theory underlying the invention
"A" document defining the general state of the art which is not considered to be of particular relevance	"X" document of particular relevance; the claimed invention cannot be considered novel or cannot be considered to involve an inventive step when the document is taken alone
"E" earlier application or patent but published on or after the international filing date	"Y" document of particular relevance; the claimed invention cannot be considered to involve an inventive step when the document is combined with one or more other such documents, such combination being obvious to a person skilled in the art
"L" document which may throw doubts on priority claim(s) or which is cited to establish the publication date of another citation or other special reason (as specified)	"&" document member of the same patent family
"O" document referring to an oral disclosure, use, exhibition or other means	
"P" document published prior to the international filing date but later than the priority date claimed	

Date of the actual completion of the international search
 9 July 2019

Date of mailing of the international search report

05 AUG 2019

Name and mailing address of the ISA/US
 Mail Stop PCT, Attn: ISA/US, Commissioner for Patents
 P.O. Box 1450, Alexandria, Virginia 22313-1450
 Facsimile No. 571-273-8300

Authorized officer:
 Lee W. Young

PCT Helpdesk: 571-272-4300
 PCT OSP: 571-272-7774

INTERNATIONAL SEARCH REPORT

International application No.

PCT/US 19/32222

C (Continuation). DOCUMENTS CONSIDERED TO BE RELEVANT

Category*	Citation of document, with indication, where appropriate, of the relevant passages	Relevant to claim No.
A	✓ WO 2018/006670 A1 (Agricultural Inst of Agriculture Jiangxi Province) 11 January 2018 (11.01.2018) Entire document	1-17