



Europäisches Patentamt  
European Patent Office  
Office européen des brevets



(11) **EP 0 988 850 B1**

(12) **EUROPEAN PATENT SPECIFICATION**

(45) Date of publication and mention  
of the grant of the patent:  
**22.09.2004 Bulletin 2004/39**

(51) Int Cl.7: **A61J 7/00, A47G 21/18**

(21) Application number: **00200063.6**

(22) Date of filing: **17.07.1996**

(54) **An oral active agent delivery system**

Eine Vorrichtung zum Verabreichen von oralen Wirkstoffen

Un dispositif d'administration d'agent oralement actif

(84) Designated Contracting States:  
**AT BE CH DE DK ES FI FR GB GR IE IT LI LU NL  
PT SE**

(30) Priority: **21.07.1995 US 131995  
03.01.1996 US 583544**

(43) Date of publication of application:  
**29.03.2000 Bulletin 2000/13**

(62) Document number(s) of the earlier application(s) in  
accordance with Art. 76 EPC:  
**96924555.4 / 0 840 591**

(73) Proprietor: **ALZA CORPORATION  
Palo Alto CA 94303-0802 (US)**

(72) Inventors:  
• **Wong, Patrick S.L.  
Palo Alto, CA 94306 (US)**

- **Rosen, Howard B.  
Los Gatos, CA 95030 (US)**
- **Roth, Nathan  
San Francisco, CA 94133 (US)**
- **Gardner, Phyllis I  
Stanford, CA 94305 (US)**

(74) Representative: **Crump, Julian Richard John et al  
FJ Cleveland,  
40-43 Chancery Lane  
London WC2A 1JQ (GB)**

(56) References cited:  
**EP-A- 0 383 503 DE-A- 1 906 964  
US-A- 2 436 505 US-A- 2 867 536  
US-A- 3 610 483 US-A- 4 792 333**

**EP 0 988 850 B1**

Note: Within nine months from the publication of the mention of the grant of the European patent, any person may give notice to the European Patent Office of opposition to the European patent granted. Notice of opposition shall be filed in a written reasoned statement. It shall not be deemed to have been filed until the opposition fee has been paid. (Art. 99(1) European Patent Convention).

## Description

**[0001]** The present invention is related to the oral delivery of an active agent. More particularly, a device for oral delivery of an active agent formulation in the form of discrete units mixed with a fluid, by inserting the discrete units into a hollow active agent formulation chamber. A retainer in a first end of the chamber prevents the release of the discrete units from the first end of the chamber while allowing for fluid flow when suction is applied at the second end of the chamber. The discrete units can easily be swallowed in admixture with the fluid drawn through the chamber.

**[0002]** Tablets, capsules, caplets and many other types of devices have been used for oral delivery of active agents. These forms are relatively easy to manufacture and convenient for use in the hospital or other institutional settings or at home. Many different types of active agents have been incorporated into such dosage forms - ranging from analgesics to antibiotics to hormones.

**[0003]** There are patients that, because of age or infirmity, have difficulty swallowing solid oral dosage forms. According to Kikendall et al., Digestive Diseases and Sciences 28:2(1983), there were 221 cases documented between 1970-1982 of tablet and capsule induced oesophageal injury. The most commonly implicated drugs were tetracycline (108 cases), emepromium bromide (36 cases), potassium chloride (16 cases) and ferrous salts (12 cases).

**[0004]** DE 1906964 discloses a drinking straw comprising a chamber which contains a liquid or solid beverage concentrate. In use the concentrate dissolves in fluid to form a beverage as the fluid is drawn through the straw and into the mouth of a user.

**[0005]** US 4792333 discloses a drug delivery device comprising a straw, which is sealed at both ends and has a circumferential constriction which prevents the movement of a single drug capsule past the constriction along the length of the straw. The user of the device holds the straw such that the capsule rests against the constriction, cuts both ends off the straw and sips a drink through the straw from one end, thereby ingesting the drug capsule as part of an admixture with the fluid. The constriction is positioned proximate the one end of the straw.

**[0006]** EP-A-0 383 503 describes a tubular system for delivering a therapeutic agent in free-flowing form to a patient. The therapeutic agent is supported within a tube by a stationary, fluid-permeable grid or within a loop formed in the tube. As fluid is drawn through the tube by the patient, the therapeutic agent is carried from the stationary grid or the loop by the fluid and dispensed to the patient.

**[0007]** There remains a need for oral dosage forms where swallowing of a large solid system is avoided that are easy to use and manufacture.

**[0008]** According to the present invention there is pro-

vided an oral active agent delivery system as claimed in claim 1 below.

**[0009]** In one embodiment, the discrete units contained within the chamber are in particulate form.

**[0010]** In a second embodiment, the discrete units contained within the chamber are in the form of multiple active agent dosage forms.

**[0011]** The present invention provides a device for the oral delivery of an active agent formulation in the form of discrete units that is easy to manufacture and use and that can deliver a predetermined amount of active agent.

**[0012]** The term "active agent formulation" intends the active agent or drug optionally in combination with pharmaceutically acceptable carriers and additional inert ingredients.

**[0013]** The term "discrete units" intends the active agent formulation in solid or particulate form.

**[0014]** An "oral dosage form" as described herein is meant the active agent formulation when placed in a discrete unit that is capable of maintaining its physical configuration and chemical integrity while housed within the delivery device.

**[0015]** As used herein, the terms "therapeutically effective amount" or "therapeutically effective rate" refer to the amount or rate of the active agent needed to effect the desired pharmacologic, often beneficial result.

**[0016]** The term "active agent formulation retainer" refers to a valve, plug or restriction, or the like that prevents passage of the active agent formulation from the device. By "fluid passing active agent formulation retainer" is intended a valve, plug or restriction or the like that allows for passage of fluids but does not allow for passage of other ingredients such as the active agent formulation that is contained in the delivery device.

**[0017]** The dispensing device of the invention find use where it is inconvenient or unsafe to use solid oral dosage forms such as capsules or tablets. The devices may be particularly useful in geriatric or paediatric patient populations but they may also be useful for those who have difficulty swallowing capsules or tablets. A single delivery device or several devices can be administered to a patient during a therapeutic program.

**[0018]** Following is a description by way of example and with reference to the accompanying drawings of embodiments of the invention.

**[0019]** In the drawings:

Fig. 1 is a cross-sectional view of one embodiment of the delivery device of the invention in prepared form.

Fig. 2 is a cross-sectional view of another embodiment of the delivery device of the present invention in prepared form.

**[0020]** Fig 1 depicts, in cross-section view, one embodiment of the delivery device according to the invention. The device is in prepared form prior to placement in the fluid. Dispensing device 40 is shown in Fig 1 to

comprise an active agent formulation chamber 42. Contained within chamber 42 are multiple oral dosage forms 44. First end 46 of the chamber 42 has a fluid passing active formulation retainer 54 prepared by crimping the chamber 42 so that the diameter of the opening 48 is smaller than the dosage form 44. In this way the dosage form 44 will not fall out of the chamber 42. Second end 50 contains an active agent formulation retainer 56 that is in the form of a removable seal 52. In operation, the first end 46 of the chamber 42 is inserted into a fluid, removable seal 52 is removed and second end 50 is placed into the mouth of the patient. The patient then sips on the end 50 so that the fluid/dosage form admixture is delivered into the oral cavity and can easily be swallowed. Dosage forms 44 may be of the instant release, delayed release, continuous release or controlled release type, depending on the pattern of drug administration desired.

**[0021]** Fig 2 is a cross-sectional view of a second embodiment that is similar to that shown in Fig. 1, but rather than a removable seal, the second end 130 is sealed with a tab 134 that can be completely removed prior to placement of the device in the fluid 30 and delivery of the oral dosage forms 44.

**[0022]** The active agent itself may be in liquid, solid, or semisolid form. The active agent formulation that contains the active agent may contain additional material such as binders, coating materials, or stabilizers such that the formulation is formed into one or more discrete units. The discrete units may be designed in a multitude of ways to provide a specific drug delivery profile. One embodiment comprises a formulation that is in particulate form. These particulates are generally between about 50 and 2000  $\mu\text{m}$  in diameter, usually between about 100-500  $\mu\text{m}$  in diameter. Where the particulate has an unpleasant taste, the particulate may be taste masked by methods that are well known in the art. The particulates may be designed to provide immediate delivery of the active agent, they may be coated to provide for prolonged release or delayed pulse release of the active agent, or they may be designed to provide for a combination of immediate, pulsed and/or prolonged delivery of active agent. The particulates may be coated with an enteric coating to provide for targeted release of the active agent. In addition there may be active agent formulations that contain more than one active agent.

**[0023]** In other embodiments, the active agent may be in liquid form and may be contained within a soft gelatin capsule or within a solid oral dosage form. These dosage forms may include, matrix or other types of tablets, pellets and elongated tablets where the height to diameter ratio exceeds one, capsules, elementary osmotic pumps, such as those described in US Patent No. 3,845,770, mini osmotic pumps such as those described in US Patent Nos. 3,995,631, 4,034,756, and 4,111,202, and multichamber osmotic systems referred to as push-pull and push-melt osmotic pumps, such as those described in US Patent Nos. 4,320,759, 4,327,725,

4,449,983, and 4,765,989 all of which are incorporated herein by reference.

**[0024]** A method for determining the release profile of active agent from solid dosage forms may be calculated as follows:

$$n=x+y+z$$

n = total number of discrete units in the device  
 x = immediate release discrete units  
 y = constant release discrete units  
 z = delayed release discrete units

Constant release will be obtained when  $x=z=0$ ; two pulse release will occur when  $y=0$ ; and constant release with an initial pulse will occur when  $z=0$ . Where none of  $x$ ,  $y$ , or  $z = 0$ , there will be an pulse/constant release/pulse release. Such systems provide for large capacity devices with the possibility of once a day dosing.

**[0025]** The term "active agent" refers to an agent, drug, compound, composition of matter or mixture thereof which provides some pharmacologic, often beneficial, effect. This includes foods, food supplements, nutrients, drugs, vitamins, and other beneficial agents. As used herein, the terms further include any physiologically or pharmacologically active substance that produces a localized or systemic effect in a patient. The active drug that can be delivered includes antibiotics, antiviral agents, antiepileptics, analgesics, anti-inflammatory agents and bronchodilators, and may be inorganic and organic compounds, including, without limitation, drugs which act on the peripheral nerves, adrenergic receptors, cholinergic receptors, the skeletal muscles, the cardiovascular system, smooth muscles, the blood circulatory system, synaptic sites, neuroeffector junctional sites, endocrine and hormone systems, the immunological system, the reproductive system, the skeletal system, autacoid systems, the alimentary and excretory systems, the histamine system and the central nervous system. Suitable agents may be selected from, for example, polysaccharides, steroids, hypnotics and sedatives, psychic energizers, tranquilizers, anticonvulsants, muscle relaxants, antiparkinson agents, analgesics, anti-inflammatories, muscle contractants, antimicrobials, antimalarials, hormonal agents including contraceptives, sympathomimetics, polypeptides and proteins capable of eliciting physiological effects, diuretics, lipid regulating agents, antiandrogenic agents, antiparasitics, neoplastics, antineoplastics, hypoglycemics, nutritional agents and supplements, growth supplements, fats, ophthalmics, antienteritis agents, electrolytes and diagnostic agents.

**[0026]** Examples of active agents useful in this invention include prochlorperazine edisylate, ferrous sulfate, aminocaproic acid, mecamlamine hydrochloride, procainamide hydrochloride, amphetamine sulfate, methamphetamine hydrochloride, benzphetamine hydro-

chloride, isoproterenol sulfate, phenmetrazine hydrochloride, bethanechol chloride, methacholine chloride, pilocarpine hydrochloride, atropine sulfate, scopolamine bromide, isopropamide iodide, tridihexethyl chloride, phenformin hydrochloride, methylphenidate hydrochloride, theophylline choline, cephalixin hydrochloride, diphenidol, meclizine hydrochloride, prochlorperazine maleate, phenoxybenzamine, thiethylperazine maleate, anisindione, diphenadione erythryl tetranitrate, digoxin, isofluorophate, acetazolamide, methazolamide, bendroflumethiazide, chlorpropamide, tolazamide, chlormadinone acetate, phenaglycodol, allopurinol, aluminum aspirin, methotrexate, acetyl sulfisoxazole, hydrocortisone, hydrocorticosterone acetate, cortisone acetate, dexamethasone and its derivatives such as betamethasone, triamcinolone, methyltestosterone, 17-b-estradiol, ethinyl estradiol, ethinyl estradiol 3-methyl ether, prednisolone, 17-b-hydroxyprogesterone acetate, 19-nor-progesterone, norgestrel, norethindrone, norethisterone, norethiederone, progesterone, norgesterone, norethynodrel, aspirin, acetaminophen, indomethacin, naproxen, fenopropfen, sulindac, indoprofen, nitroglycerin, isosorbide dinitrate, propranolol, timolol, atenolol, alprenolol, cimetidine, clonidine, imipramine, levodopa, chlorpromazine, methylidopa, dihydroxyphenylalanine, calcium gluconate, ketoprofen, ibuprofen, cephalixin, erythromycin, haloperidol, zomepirac, ferrous lactate, vincamine, phenoxybenzamine, diltiazem, milrinone, captopril, mandol, quabenz, hydrochlorothiazide, ranitidine, flurbiprofen, fenbufen, fluprofen, tolmetin, alclofenac, mefenamic, flufenamic, difuninal, nimodipine, nitrendipine, nisoldipine, nicardipine, felodipine, lidoflazine, tiapamil, gallopamil, amlodipine, mioflazine, lisinopril, enalapril, captopril, ramipril, enalaprilat, famotidine, nizatidine, sucralfate, etintidine, tetralolol, minoxidil, chlordiazepoxide, diazepam, amitriptyline, and imipramine. Further examples are proteins and peptides which include, but are not limited to, insulin, colchicine, glucagon, thyroid stimulating hormone, parathyroid and pituitary hormones, calcitonin, renin, prolactin, corticotrophin, thyrotropic hormone, follicle stimulating hormone, chorionic gonadotropin, gonadotropin releasing hormone, bovine somatotropin, porcine somatotropin, oxytocin, vasopressin, prolactin, somatostatin, lypressin, pancreozymin and luteinizing hormone.

**[0027]** It is to be understood that more than one active agent may be incorporated into the active agent formulation in a device of this invention, and that the use of the term "agent" in no way excludes the use of two or more such agents.

**[0028]** The agents can be in various forms, such as soluble and insoluble charged or uncharged molecules, components of molecular complexes or nonirritating, pharmacologically acceptable salts.

**[0029]** The amount of active agent employed in the delivery device will be that amount necessary to deliver a therapeutically effective amount of the agent to

achieve the desired result. In practice, this will vary widely depending upon the particular agent, the severity of the condition, and the desired therapeutic effect. However, the device is generally useful for active agents that must be delivered in fairly large doses of from about 100 mg to 5000 mg, usually in the range of from about 250 mg to about 2500 mg. However, since the devices may also be useful in pediatric patients, doses in the ranges of 25 to 250 mg are also contemplated herein.

**[0030]** Representative materials for forming devices including the active agent formulation chamber, the elongated tubular member, the end caps and tabs, include, without limitation, paper, plastic such as propylene/styrene copolymers, polypropylene, high density polyethylene, low density polyethylene and the like. The devices usually have an inner diameter of between about 3 and 8 mm and a wall thickness of between about 0.1 and 0.4 mm. The devices are between about 10 and 30 cm in length.

**[0031]** The fluid passing active agent formulation retainer permits the free flow of liquid medium but prohibits passage of the active agent formulation from the device prior to delivery.

**[0032]** The fluid that is used for suspending the active agent formulation by sipping through the active agent formulation chamber is preferably any good-tasting liquid including but not limited to water, juice, milk, soda, coffee, tea etc. Care must be taken to ensure compatibility of the fluid with the active agent formulation.

**[0033]** The following example is illustrative of the present invention. It is not to be construed as limiting the scope of the invention.

## EXAMPLES

### **Example 1**

**[0034]** A delivery device according to the present invention was prepared as follows. Jumbo size straws with an inside diameter of 0.21 inches and a length of 6 inches were heat sealed at one end. The seal was partially cut off so that the orifice had a diameter of less than 5 mm.

**[0035]** Small elementary osmotic pumps of calcium ascorbate were prepared as follows. The core compartment was formed from 50 mg of calcium ascorbate, 2.7 mg polyvinyl pyrrolidone and 0.6 mg of magnesium stearate. The ingredients were thoroughly mixed and pressed in a Manesty press with a 3/16 inch round punch using a pressure head of 1 1/2 tons. A semipermeable wall of 5 mg was formed by blending 80% cellulose acetate having an acetyl content of 39.0%, 10% sorbitol and 5% polyethylene glycol 400. The solution was spray coated onto the core compartment with a solvent consisting of 714 ml of acetone and 186 ml of water in an air suspension machine. The coated osmotic tablet was dried for 72 hours at 50°C. A 0.2 mm orifice was hand drilled into the wall.

**[0036]** Twenty of the small osmotic systems with a total dose of 1000 mg of calcium ascorbate were placed inside the straw from the open end. The partially sealed end of the straw was placed into a glass of water. The twenty small osmotic dosage forms were easily sipped into the mouth with a small amount of suction to provide a prolonged release of Vitamin C.

## Claims

1. An oral active agent delivery system (40) for delivering discrete units (44) of active agent formulation in admixture with a fluid, said system comprising:

a hollow active agent formulation chamber (42; 132) having a first end (46) and a second end (50;130) and containing an active agent formulation (44), said ends (42,50;130) being adapted to pass fluid during delivery of the active agent formulation; and  
a fluid passing active agent retainer (54) for preventing release of the discrete units from the first end (46) of the chamber while permitting fluid entry into the chamber;

**characterized in that** said active agent formulation is in the form of a plurality of discrete units, and said first end is the distal end of the system and said second end is the proximal end of the system and said fluid passing active agent retainer (54) comprises a restriction in the cross-sectional area of the formulation chamber (42;132) at said first end (46), and each of said discrete units (44) has a diameter greater than said restriction to prohibit the passage of the discrete units (44) from said first end (46), said formulation chamber being configured such that upon inserting said first end (46) into a fluid, and sipping on said second end (50;130), said discrete units are delivered from the second end (50;130) in admixture with said fluid.

2. An oral active agent delivery system as claimed in claim 1, **characterised in that** said formulation chamber (42;132) is crimped at said first end (46) to form said restriction.

3. The delivery system of claim 1 or claim 2 further comprising an active agent formulation retainer (52; 134) in the second end (50;130) of the active agent formulation chamber (42;132) for preventing release of said active agent formulation from said second end (50;130) prior to use.

4. The delivery system of claim 1 wherein said discrete units are selected from the group consisting of particles, oral dosage forms and combinations thereof.

5. The delivery system of claim 4 wherein said discrete units provide for prolonged delivery of the active agent in said formulation.

6. The delivery system of claim 4 wherein said discrete units provide for immediate delivery of the active agent in said formulation.

7. The delivery system of claim 4 wherein said discrete units provide for delayed pulsed delivery of said active agent in said formulation.

8. The delivery system of claim 4 wherein said discrete units comprise oral dosage forms that comprise an osmotic layer and an active agent layer.

9. The delivery system of claim 1 further comprising an end cap concentrically surrounding the first end (46) of the chamber.

10. The delivery system of claim 3 wherein said active agent formulation retainer (52;134) in the second end (50;130) of the chamber comprises a rotary valve.

11. The delivery system of claim 3 wherein said active agent formulation retainer (52;134) in the second end (50;130) of the chamber comprises a narrowing in the second end (50;130) of the chamber.

12. The delivery system of claim 2 wherein said active agent formulation retainer (52;134) in the second end (50;130) of the chamber comprises a removable end cap.

13. The delivery system of claim 1 wherein said active agent formulation comprises an active agent selected from the group consisting of antibiotics, antiviral agents, anepileptics, analgesics, anti-inflammatory agents and bronchodilators.

## Patentansprüche

1. Wirkstoff-Verabreichungssystem (40) zur oralen Verabreichung diskreter Einheiten (44) einer Wirkstoffformulierung unter Beimischung eines Fluids, wobei das System umfasst:

eine hohle Kammer (42; 132) für die Wirkstoffformulierung, wobei die Kammer ein erstes Ende (46) und ein zweites Ende (50; 130) hat und eine Wirkstoffformulierung (44) enthält, wobei die Enden (42, 50; 130) dazu geeignet sind, während der Verabreichung der Wirkstoffformulierung Fluid durchzulassen, und

eine Fluid durchlassende und die Wirkstofffor-

mulierung zurückhaltende Rückhaltevorrichtung (54), um die Freisetzung der diskreten Einheiten aus dem ersten Ende (46) der Kammer zu verhindern, während der Eintritt von Fluid in die Kammer gestattet wird,

**dadurch gekennzeichnet, dass** die Wirkstoffformulierung in Form einer Vielzahl von diskreten Einheiten vorliegt, dass das erste Ende das distale Ende des Systems und das zweite Ende das proximale Ende des Systems ist, dass die Fluid durchlassende und die Wirkstoffformulierung zurückhaltende Rückhaltevorrichtung (54) eine Restriktion der Querschnittsfläche der Formulierungskammer (42; 132) an dem ersten Ende (46) umfasst und dass jede der diskreten Einheiten (44) einen Durchmesser hat, der größer als die Restriktion ist, um das Austreten der diskreten Einheiten (44) aus dem ersten Ende (46) zu verhindern, wobei die Formulierungskammer derart konfiguriert ist, dass beim Einsetzen des ersten Endes (46) in ein Fluid und beim Nippen an dem zweiten Ende (50; 130) die diskreten Einheiten aus dem zweiten Ende (50; 130) unter Beimischung des Fluids abgegeben werden.

2. Wirkstoff-Verabreichungssystem zur oralen Wirkstoffverabreichung nach Anspruch 1, **dadurch gekennzeichnet, dass** die Kammer (42; 132) für die Formulierung an dem ersten Ende (46) gebördelt ist, um die Restriktion auszubilden.
3. Verabreichungssystem nach Anspruch 1 oder Anspruch 2, ferner umfassend eine den Wirkstoff zurückhaltende Rückhaltevorrichtung (52; 134) in dem zweiten Ende (50; 130) der Wirkstoffformulierungskammer (42; 132), um die Freisetzung der Wirkstoffformulierung aus dem zweiten Ende (50; 130) vor dem Gebrauch zu verhindern.
4. Verabreichungssystem nach Anspruch 1, wobei die diskreten Einheiten aus der Gruppe ausgewählt werden, die aus Partikeln, oralen Verabreichungsformen und Kombinationen derselben besteht.
5. Verabreichungssystem nach Anspruch 4, wobei die diskreten Einheiten eine Verabreichung des Wirkstoffes in der Formulierung über einen längeren Zeitraum vorsehen.
6. Verabreichungssystem nach Anspruch 4, wobei die diskreten Einheiten eine sofortige Abgabe des Wirkstoffes in der Formulierung vorsehen.
7. Verabreichungssystem nach Anspruch 4, wobei die diskreten Einheiten eine verzögerte intermittierende Abgabe des Wirkstoffes in der Formulierung vorsehen.

5

10

15

20

25

30

35

40

45

50

55

8. Verabreichungssystem nach Anspruch 4, wobei die diskreten Einheiten orale Verabreichungsformen umfassen, die eine osmotische Schicht und eine Wirkstoffschicht enthalten.

9. Verabreichungssystem nach Anspruch 1, ferner umfassend eine Stirnkappe, die das erste Ende (46) der Kammer konzentrisch umgibt.

10. Verabreichungssystem nach Anspruch 3, wobei die die Wirkstoffformulierung zurückhaltende Rückhaltevorrichtung (52; 134) in dem zweiten Ende (50; 130) der Kammer ein Drehventil enthält.

11. Verabreichungssystem nach Anspruch 3, wobei die die Wirkstoffformulierung zurückhaltende Rückhaltevorrichtung (52; 134) in dem zweiten Ende (50; 130) der Kammer eine Engstelle in dem zweiten Ende (50; 130) der Kammer umfasst.

12. Verabreichungssystem nach Anspruch 2, wobei die die Wirkstoffformulierung zurückhaltende Rückhaltevorrichtung (52; 134) in dem zweiten Ende (50; 130) der Kammer eine abnehmbare Stirnkappe enthält.

13. Verabreichungssystem nach Anspruch 1, wobei die Wirkstoffformulierung einen Wirkstoff enthält, der aus der Gruppe ausgewählt wird, die aus Antibiotika, Antivirenmitteln, Antiepileptika, Analgetika, Antiphlogistika und Bronchodilatoren besteht.

## Revendications

1. Dispositif d'administration d'agent oralement actif (40) pour administrer des unités individuelles (44) d'une formulation d'agent actif en mélange avec un fluide, ledit dispositif comprenant :

une chambre creuse pour formulation d'agent actif (42 ; 132) ayant une première extrémité (46) et une seconde extrémité (50 ; 130) et contenant une formulation d'agent actif sous la forme d'une pluralité d'unités individuelles (44), lesdites extrémités (42, 50; 130) étant adaptées au passage d'un fluide pendant l'administration de la formulation d'agent actif ; et une retenue de l'agent actif au passage du fluide (54) pour empêcher la libération des unités individuelles par la première extrémité (46) de la chambre tout en permettant l'entrée du fluide dans la chambre;

**caractérisé en ce que** ladite formulation d'agent actif est sous la forme d'une pluralité d'unités individuelles, et ladite première extrémité est l'extrémité distale du dispositif et ladite seconde extrémité

- est l'extrémité proximale du dispositif et ladite retenue (54) de l'agent actif au passage du fluide comprend un étranglement dans la zone de section transversale de la chambre de préparation (42 ; 132) à ladite première extrémité (46), et chacune desdites unités individuelles (44) a un diamètre plus important que ledit étranglement pour interdire le passage des unités individuelles (44) par ladite première extrémité (46), ladite chambre pour formulation étant configurée de telle manière qu'en introduisant ladite première extrémité (46) dans un fluide, et en aspirant par ladite seconde extrémité (50 ; 130), lesdites unités individuelles sont administrées par la seconde extrémité (50 ; 130) en mélange avec ledit fluide.
2. Dispositif d'administration d'agent oralement actif selon la revendication 1, **caractérisé en ce que** ladite chambre pour formulation (42 ; 132) est ourlée à ladite première extrémité (46) pour former ledit étranglement.
3. Dispositif d'administration selon la revendication 1 ou la revendication 2 comprenant en outre une retenue (52 ; 134) de formulation d'agent actif à la seconde extrémité (50 ; 130) de la chambre pour formulation d'agent actif (42 ; 132) pour empêcher la libération de ladite formulation d'agent actif par ladite seconde extrémité (50 ; 130) avant l'utilisation.
4. Dispositif d'administration selon la revendication 1 dans lequel lesdites unités individuelles sont choisies parmi le groupe constitué par les particules, les formes posologiques orales et les combinaisons de celles-ci.
5. Dispositif d'administration selon la revendication 4 dans lequel lesdites unités individuelles offrent une administration prolongée de l'agent actif dans ladite formulation.
6. Dispositif d'administration selon la revendication 4 dans lequel lesdites unités individuelles offrent une administration immédiate de l'agent actif dans ladite formulation.
7. Dispositif d'administration selon la revendication 4 dans lequel lesdites unités individuelles offrent une administration retardée intermittente de l'agent actif dans ladite formulation.
8. Dispositif d'administration selon la revendication 4 dans lequel lesdites unités individuelles comprennent des formes posologiques orales qui comprennent une couche osmotique et une couche d'agent actif.
9. Dispositif d'administration selon la revendication 1,
- comprenant en outre un bouchon d'extrémité entourant concentriquement la première extrémité (46) de la chambre.
- 5 10. Dispositif d'administration selon la revendication 3 dans lequel ladite retenue (52 ; 134) de formulation d'agent actif à la seconde extrémité (50 ; 130) de la chambre comprend une valve rotative.
- 10 11. Dispositif d'administration selon la revendication 3 dans lequel ladite retenue (52 ; 134) de formulation d'agent actif à la seconde extrémité (50 ; 130) de la chambre comprend un rétrécissement à la seconde extrémité (50 ; 130) de la chambre.
- 15 12. Dispositif d'administration selon la revendication 2 dans lequel ladite retenue (52 ; 134) de formulation d'agent actif à la seconde extrémité (50 ; 130) de la chambre comprend un bouchon d'extrémité amovible.
- 20 13. Dispositif d'administration selon la revendication 1 dans lequel ladite formulation d'agent actif comprend un agent actif choisi dans le groupe consistant en les antibiotiques, les agents antiviraux, les antiépileptiques, les analgésiques, les agents anti-inflammatoires et les broncho-dilatateurs.
- 25
- 30
- 35
- 40
- 45
- 50
- 55

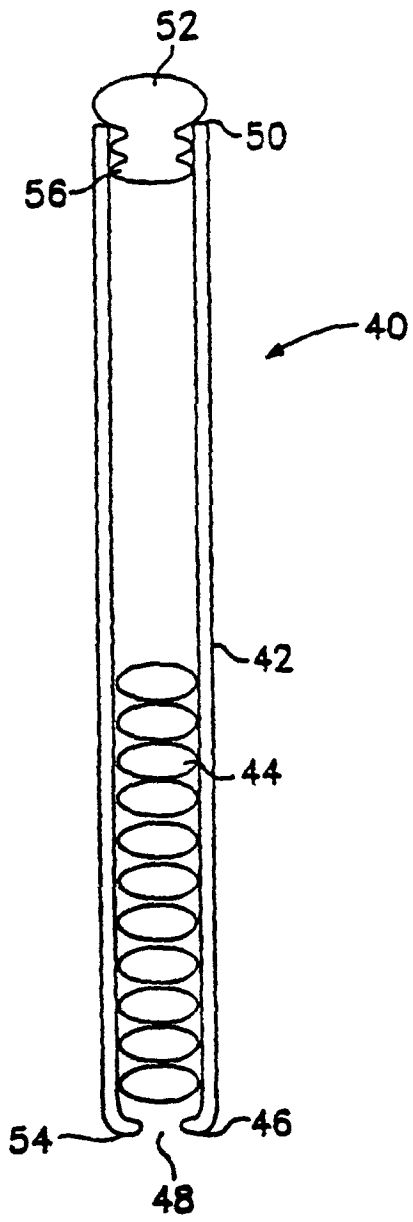

Figure 1

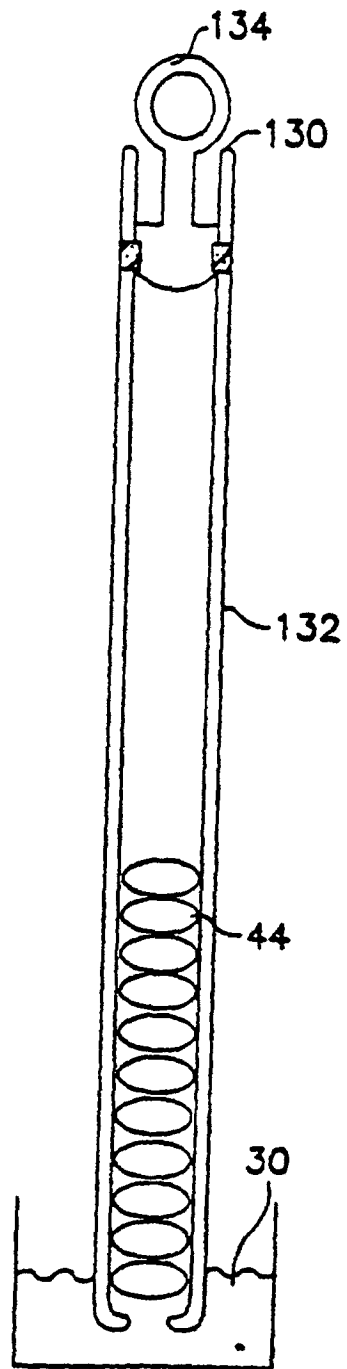

Figure 2