

G. Waterman,

Washing Machine,

No. 2,084.

Patented May 11, 1841.

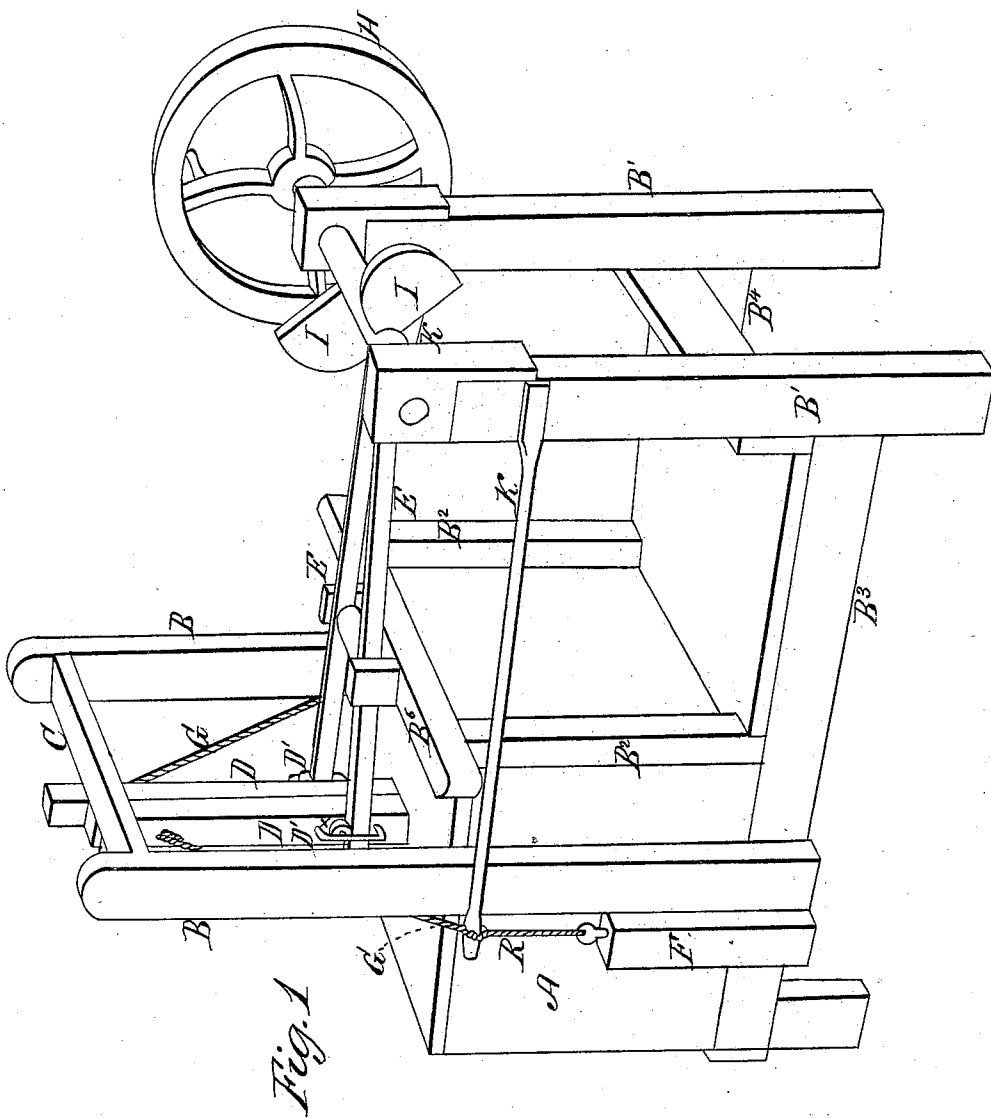

G. Waterman,

Washing Machine,

No. 2,084.

Patented May 11, 1841.

Fig. 4

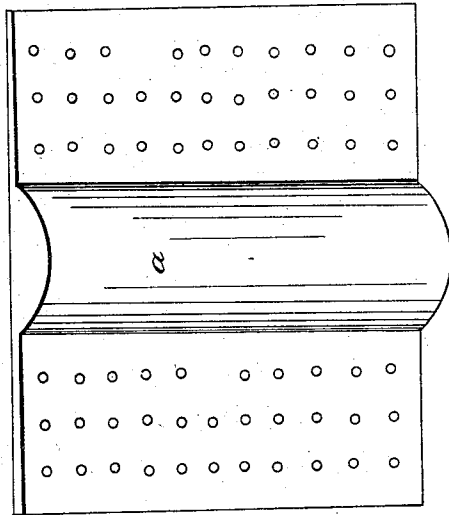
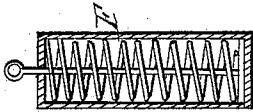

Fig. 5

Fig. 2

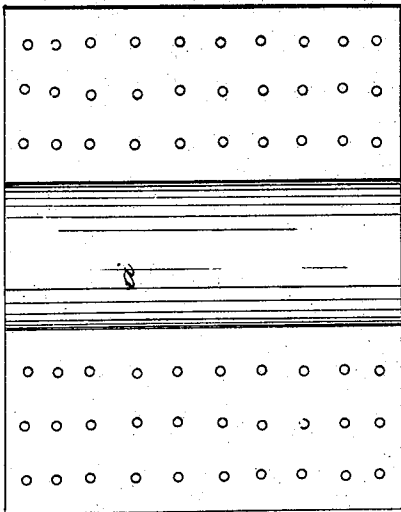
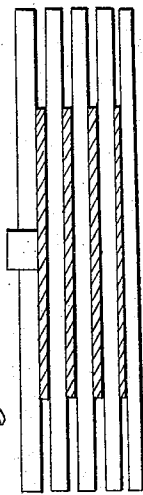

Fig. 3



UNITED STATES PATENT OFFICE.

GEO. WATERMAN, OF JOHNSTON, RHODE ISLAND.

MACHINE FOR WASHING CLOTHES.

Specification of Letters Patent No. 2,084, dated May 11, 1841.

To all whom it may concern:

Be it known that I, GEORGE WATERMAN, of Johnston, in the county of Providence, State of Rhode Island, and Providence Plantations, have invented a new and useful Improvement in Washing-Machines for Wearing-Apparel, Household Clothing, &c., which is described as follows, reference being had to the annexed drawings, making a part of the same.

Figure 1 represents a perspective view of the machine. Fig. 2 the vibrating bottom. Fig. 3 one of the beaters. Fig. 4 springbox and spring. Fig. 5 showing the end of the vibrating bottom in perspective.

The letters in the drawing correspond to the same parts in the specification.

The frame is composed of two side pieces B³ B⁴ on two feet at the back end of the machine, and inserted into the uprights B' B' at the other end, about the height of the feet before mentioned. The two uprights B' B' are in front of the machine, the lowermost end of each forming the feet, and rising high enough for the support of the axle of the balance wheel H to be described, two other uprights B² B² are raised on these side pieces, and rise a little higher than the top of the washing box A. A cap piece B⁰ connects these uprights and about midway of this cap piece, is the fulcrum of the levers E E.

The washing box A is of a square or rectangular form, of any suitable dimensions, and supported on the side pieces of the frame, at the back end of the machine. Two uprights B B are attached to this box, one on each side thereof, and passing up about twice the height of the washing box, and are connected together by a cross girth C, about the middle of this girth are two brackets, one for each dasher to confine the said dashers, so that they may move vertically. This washing box is provided with a movable cover of any desired form.

The dashers D D are composed of long rods, having at their lower end a beater as represented in Fig. 3. These rods work side by side, the beater being placed on each rod on one side, about half way up each rod, a loop D' is attached, in the upper end of which is a small roller *x*. Near the upper end of each rod, there is a suitable or any desired fixture to which a string G can be attached from the spring lever K.

The vibrating bottom, Figs. 2 and 5.—

This bottom vibrates vertically upward and downward on a semi cylindrical shaped piece of wood *a* placed on the under side. The size of the bottom is equal to that of the interior of the washing box, through this bottom any desired number of holes are pierced from the top to the bottom.

The beaters, are similar to each other, and are attached to the lower ends of the rods D before described. The bottom or under side of each beater is cut into a suitable number of straight grooves, from the bottom of said grooves to the top of the beater, at a suitable distance from each end, apertures are made, so as to allow the soap and water to pass through.

*The spring box F, Fig. 4.—*There are two of these, one on each side of the washing box, and close to one side of each upright B before mentioned on the outside of the washing box, these boxes are of wood, and each contains a spiral spring, to which is attached a string or rope R leading to the end of the spring lever K.

The levers E, E, are each made of wood, and resting in a suitable position on the cap piece before mentioned on the two small uprights B² B² one end of each lever (that end which is adjacent to the washing box) is passed under the roller in the loop attached to each rod before mentioned, and sufficiently long to be operated upon by the cams I I on the axle of the balance wheel H.

The spring levers K K are each made of wood and elastic extending from the uprights B' B' to a point just over the spring box F, to each of the said levers is attached a string or rope extending from the spring in the box E, and also a string or rope G from the upper end of the rods before mentioned.

The balance wheel H is attached to an axle P which rests on the top of the two uprights B' B', the outside of this wheel has attached to it a handle for the operator to lay hold of, on this axle, and between the uprights or supports before mentioned are attached two segments I I acting cams on the levers E E, and so arranged that they may act upon the lever alternately, the whole of the above may be of iron or any other suitable material.

*Operation.—*The vibrating bottom being placed on the bottom of the washing box inside, the clothes, &c., to be washed are put in with a sufficient quantity of soap and

water, the beaters being above the clothes, are set in motion upward, and downward by the levers E E, being moved by the cams I I on the axle containing the balance wheel
5 H the vibrating bottom moves on its curved bottom by the motion of the beaters, the elasticity of the spring levers, assisted by the spiral spring on the box F brings down the beaters with any required force.

What I claim as my invention and improvement and which I desire to secure by Letters Patent is—

The vibrating bottom in combination with the dashers as specified and described.

GEORGE WATERMAN.

Witnesses:

JOSEPH A. WEEDEN,
HENRY MARTIN.