

Feb. 11, 1947.

S. WIDLARZ

2,415,545

FABRIC DRILL

Filed Jan. 10, 1945

2 Sheets-Sheet 1

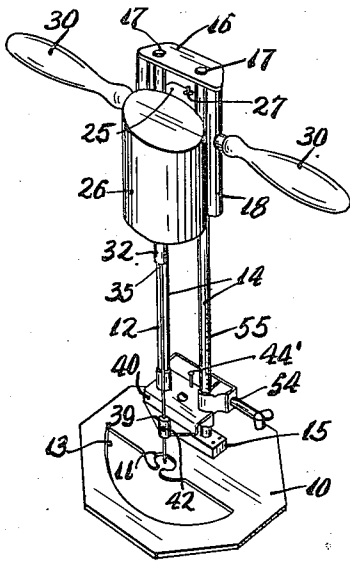

FIG - 1

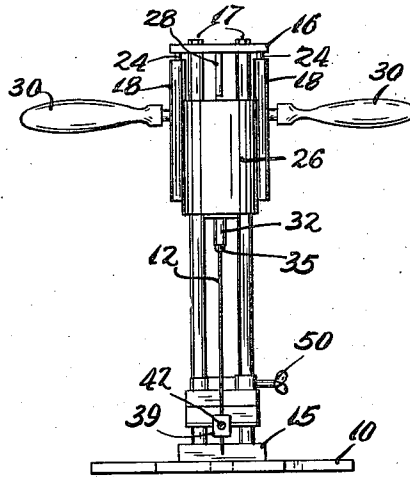

FIG - 2

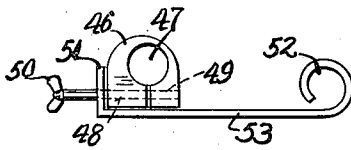

FIG - 4

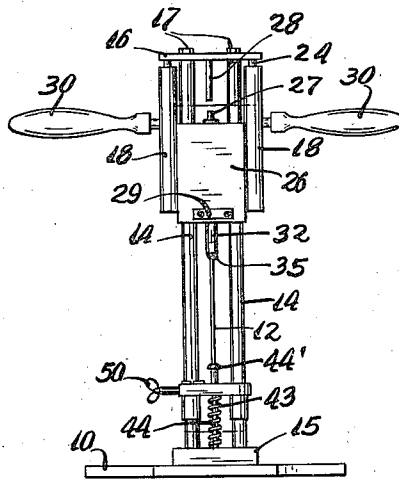

FIG - 3

INVENTOR.  
Stanley Widlarz

BY

*John H. Schick*

ATTORNEY.



# UNITED STATES PATENT OFFICE

2,415,545

## FABRIC DRILL

Stanley Widlarz, Hollis, N. Y.

Application January 10, 1945, Serial No. 572,215

8 Claims. (Cl. 164-86)

1 This invention relates to new and useful improvements in a fabric drill.

More specifically, the present invention proposes the construction of a fabric drill for marking the respective layers of a pile of fabric by piercing holes therein, the drill being employable in the clothing industry and other industries in which fabric is operated on.

Exemplifying its use in the clothing industry, it may be stated that where garments are made in quantity on similar patterns, it is the practice to lay the fabric or cloth in layers to form a pile of the fabric, the pile of fabric being cut throughout its thickness according to the desired pattern for forming layers of such piled fabric. The layers of fabric, either prior to or after the cutting, are provided with holes to denote the location of flaps, buttons, button holes, pockets, and for other purposes, in order to serve as guides in subsequent operations upon the material.

Still further, the present invention proposes the construction of a fabric drill having a drill needle supporting carriage slidably supported on guides, and an adjustable means for limiting the extent of sliding.

A further object of the present invention is to provide a fabric drill as aforesaid, having an improved carriage.

For further comprehension of the invention, and of the objects and advantages thereof, reference will be had to the following description and accompanying drawings, and to the appended claims in which the various novel features of the invention are more particularly set forth.

In the accompanying drawings forming a material part of this disclosure:

Fig. 1 is a perspective view of a fabric drill constructed in accordance with this invention.

Fig. 2 is a front view of the drill.

Fig. 3 is a rear view of the drill.

Fig. 4 is an enlarged view of the adjustable stop of the drill.

Fig. 5 is an enlarged plan view of the drill.

Fig. 6 is an enlarged perspective view of a top portion of the drill showing a lowered position of the carriage.

Fig. 7 is an enlarged perspective view of the bottom portion of the drill.

Fig. 8 is a fragmentary partial sectional view showing the manner of assembling the drilling needle with the drill.

Fig. 9 is an enlarged front view of the drill, partly in central section.

The fabric drill, according to this invention, includes a base 10 which is adapted to be placed

2 on a pile of sheets of cloth or the like to be marked by the drill, as for instance, to have a hole drilled through the pile indicating the spot at which a button hole is to be made. After one hole is made through the pile, the drill may be manually moved to another spot to make another hole through the pile to indicate some other operation later to be made.

The base 10 is a relatively thick plate of metal forming a support for the rest of the drill as well as a member to press downward on top of the pile of material to be drilled. It is provided with an orifice 11 through which the drill needle 12 will extend during drilling. A large opening 13 is provided opening into one side of the orifice 11 so that the user of the drill can easily locate the place where the hole is to be drilled.

Upstanding from and secured to the base 10 are two cylindrical spaced guides 14, the bottom ends of the guides being disposed in a boss 15 secured to the base 10. The top ends of the guides are secured by a plate 16 and bolts 17, the plate 16 extending beyond the guides 14.

A carriage 18 is slidably mounted on the guides. It has a box-like part 19 supporting sleeves (not shown) slidably mounted on the guides. On either side of the carriage 18 are two cylindrical spring housings 20 which are secured to the part 19. Part 19 has a bottom plate 21.

A tension spring 22 is disposed in each housing 20. Each spring 22 is secured at its bottom to its housing by a bolt 23 and at its top to an orificed lug 24 secured to the plate 16. The top of the part 19 is closed by a plate 25.

An electric motor 26 is vertically secured to the part 19 for sliding movement on the guides 14 with the carriage. The motor is provided with a switch 27 adapted to be operated by a pin 28 depending from the plate 16 so that when the motor is at the top of the guides, the current is off, and when the motor is moved downward, the current goes on. The motor is provided with a plug 29 for attachment to an electric wire (not shown) for supplying the motor with current. Two handles 30 extending laterally from the sides of the carriage, provide means for manually moving the carriage downward. When the carriage is so moved downward, the tension springs are stretched, so that when the handles are released, the tension springs return the motor to the top of the guides, the current being turned off when the motor reaches the top by the pin 28 hitting the switch 27. The switch is carried in a case 31 which also acts as a member securing the motor, by means of screws, to the parts 19.

3

The motor is provided with a threaded spindle 32 having a tapered end 33. The drill needle 12 has a member 34 at its upper end adapted to fit over the tapered end 33 and a lock chuck member 35, threaded on spindle 32, secures the drill needle to the motor for rotation thereby. A nut 36 is threaded on the spindle and pinned thereto by a pin 37, forming a stop preventing the member 35 from being turned up too far. This nut is only operative when the member 35 is screwed on the spindle 32 without a needle, as when the device is not in use. It prevents the member 35 from being turned up tight against the end 33, which, if it happened, might damage end 33. The needle has a sharp angular chisel-like point 38.

As the drill needle is quite long, in order that it may drill through a pile of fabric, it is supported just above the base 10 by a sleeve 39 which is carried by an S-shaped plate 40 having two orificed bosses 41 mounted on the bottoms of the guides 14, the orifice of the sleeve 39 being large enough for the drill needle to rotate therein freely. A set screw 42 is provided in the sleeve for locking the drill needle in any desired lowered position when it is desired to pin down a pile of fabric during a period in which the motor is idle and the fabric is being worked on manually. The bosses slide freely on the guides 14 and are supported slightly above the boss 15 by a compression spring 43 disposed between the top horizontal portion of the plate 40 and the boss 15. A bolt 44 secured at its lower end in the boss 15 extends through the spring 43 and through the horizontal portion of the plate, retaining the spring which urges an upward movement of the S-shaped plate.

Thus the spring 43 and plate 40 form a shock absorbing guide plate, acting to slow up the vertical movement of the motor as it approaches the lowermost possible position and keeping it and the carriage from sharply hitting adjacent parts of the drill. The shock absorbing takes place when the plate 21 engages the top of another extension boss 44' and pushes the plate 40 downward against the force of the compression spring 43 until the bosses 41 engage the boss 15. This lowered position will bring the sleeve 39 closer to the base 10 and will guide the drill needle 12 more accurately at its lowermost position.

The distance that the motor must be moved downward by the handles 30 depends upon the depth of the pile of fabric that must be pierced. It is quite important that the motor, that is the carriage, be stopped as soon as the pile is pierced because if the motor is moved further than necessary, many factors arise which prevent efficient use of the drill. As examples of these undesirable features, more current than necessary is used; the user of the drill performs unnecessary work and therefore decreases the amount of useful work he produces as well as becoming unnecessarily tired, also that the needle revolving unnecessarily through the pile may do harm to the pile, such as burning. Therefore means are provided for limiting the downward movement of the needle to the extent needed for piercing the pile of fabric and no further.

This stop, indicated generally by the reference numeral 45, is best shown in Fig. 4. It is formed of a split clamp 46 having an orifice 47 through which one of the guides 14 extends. The clamp is also provided with an unthreaded orifice 48 and a threaded orifice 49 in line therewith, both orifices 48 and 49 being at right angles to orifice 47. A wing screw 50 is disposed through the orifice 48 and threaded in the orifice 49 for tighten-

4

ing the clamp on its guide 14. A strip of metal is associated with the clamp to provide means engaging the other guide 14. This strip has a portion 51 engaging one side of the clamp and having an orifice in line with the orifice 48, a curved ring portion 52 through which the other guide 14 extends, and a portion 53 connecting the portions 51 and 52. The threaded portion of the wing screw is reduced providing a shoulder 54 bearing against the portion 51 and holding it tightly to the clamp. The stop, due to the fact that it has portions associated with each of the guides, provides a strong stop for the carriage which will not bend out of shape or be deformed from repeated contact with the carriage.

The stop 45 may be slid to any desired position on the guides 14 and locked thereto by tightening up the wing screw 50. A scale 55 is provided on one of the guides 14 indicating the depth the needle will pierce for different positions of the stop. The stop 45 is disposed on the guides 14 so that the portion 53 is on the opposite side of the guides from the motor 26, as is best shown in Fig. 1. As the motor is moved downward, the stop is eventually engaged by the plate 21, stopping further movement of the carriage. As the spindle of the motor extends considerably below the plate 21, when the stop is at its lowermost position, it permits the plate 21 to engage the boss 44' as aforesaid to shock absorb the downward movement of the motor.

For the foregoing description of the fabric drill, it will be seen that a simple, portable device, easily operated, is provided for marking by drilling holes through a pile of fabric, the device having means for adjustably limiting the downward movement of the drill needle and means for steadying the drill needle and shock absorbing full downward movement of the carriage supporting the electric motor. Moreover, the use of tension springs rather than compression springs to return the motor to its uppermost position permits full downward movement of the motor and carriage. That is to say, if compression springs were employed beneath the carriage and on the guides, as is often done, after the compression springs became solid, no further downward movement of the carriage would be possible.

While I have illustrated and described the preferred embodiments of my invention, it is to be understood that I do not limit myself to the precise constructions herein disclosed and the right is reserved to all changes and modifications coming within the scope of the invention as defined in the appended claims.

Having thus described my invention, what I claim as new, and desire to secure by United States Letters Patent, is:

1. A fabric drill for making marking holes in a pile of fabric, comprising a base, spaced guides supported thereon, a carriage slidably mounted on said guides, an electric motor secured to said carriage having a spindle, a drill needle secured to said spindle for rotation thereby, tension springs secured at their tops at the top of said guides and at their bottoms to said carriage for stretching when said carriage is moved downward and for recoil to lift said carriage, a switch for said motor carried by said carriage, a pin carried by said guides adapted to turn said switch off when said carriage is at its uppermost position, a sleeve adjacent said base through which said drill needle rotatably extends for supporting said needle, said sleeve being slidably connected to said guides and supported on top of a

compression spring supported on said base and being adapted to be engaged by said spindle to cushion downward movement of said carriage, and an adjustable stop for limiting the downward movement of said carriage including a split clamp slidably disposed on one of said guides, a ring slidably disposed on the other of said guides, means securing said clamp and ring on the opposite side of said guides from said motor, and a wing screw associated with said clamp for tightening same on its correlated guide.

2. A fabric drill for making marking holes in a pile of fabric, comprising a base, spaced guides supported thereon, a carriage slidably mounted on said guides, an electric motor secured to said carriage having a spindle, a drill needle secured to said spindle for rotation thereby, tension springs secured at their tops at the top of said guides and at their bottoms to said carriage for stretching when said carriage is moved downward and for recoil to lift said carriage, a switch for said motor carried by said carriage, a pin carried by said guides adapted to turn said switch off when said carriage is at its uppermost position, a sleeve adjacent said base through which said drill needle rotatably extends for supporting said needle, said sleeve being slidably connected to said guides and supported on top of a compression spring supported on said base and being adapted to be engaged by said spindle to cushion downward movement of said carriage, and an adjustable stop for limiting the downward movement of said carriage including a split clamp slidably disposed on one of said guides, a ring slidably disposed on the other of said guides, means securing said clamp and ring on the opposite side of said guides from said motor, and a wing screw associated with said clamp for tightening same on its correlated guide, said means further having a portion squeezed between said wing screw and clamp.

3. A fabric drill for making marking holes in a pile of fabric, comprising a base, spaced guides supported thereon, a carriage slidably mounted on said guides, an electric motor secured to said carriage having a spindle, a drill needle secured to said spindle for rotation thereby, tension springs secured at their tops at the top of said guides and at their bottoms to said carriage for stretching when said carriage is moved downward and for recoil to lift said carriage, a switch for said motor carried by said carriage, a pin carried by said guides adapted to turn said switch off when said carriage is at its uppermost position, a sleeve adjacent said base through which said drill needle rotatably extends for supporting said needle, said sleeve being slidably connected to said guides and supported on top of a compression spring supported on said base and being adapted to be engaged by said spindle to cushion downward movement of said carriage, and an adjustable stop for limiting the downward movement of said carriage including a split clamp slidably disposed on one of said guides, a ring slidably disposed on the other of said guides, means securing said clamp and ring on the opposite side of said guides from said motor, and a wing screw associated with said clamp for tightening same on its correlated guide, and a scale on one of said guides adapted to coact with said stop for indicating the effective piercing length of said needle for any adjusted position of said stop.

4. A fabric drill for making marking holes in a pile of fabric, comprising a base having an

upstanding boss, spaced guides supported on said boss, a carriage slidably mounted on said guides, an electric motor secured to said carriage having a spindle, a drill needle secured to said spindle for rotation thereby, tension springs secured at their tops at the top of said guides and at their bottoms to said carriage for stretching when said carriage is moved downward and for recoil to lift said carriage, a switch for said motor carried by said carriage, a pin carried by said guides adapted to turn said switch off when said carriage is at its uppermost position, a sleeve adjacent said base through which said drill needle rotatably extends for supporting said needle, an S-shaped member having a portion supporting said sleeve and another portion slidably mounted on said guides and supported on top of a compression spring supported on said boss, said sleeve adapted to be engaged by said spindle to cushion downward movement of said carriage, and an adjustable stop for limiting the downward movement of said carriage including a split clamp slidably disposed on one of said guides, a ring slidably disposed on the other of said guides, means securing said clamp and ring on the opposite side of said guides from said motor, and a wing screw associated with said clamp for tightening same on its correlated guide.

5. A fabric drill for making marking holes in a pile of fabric, comprising a base, having an upstanding boss, spaced guides supported on said boss, a carriage slidably mounted on said guides, an electric motor secured to said carriage having a spindle, a drill needle secured to said spindle for rotation thereby, tension springs secured at their tops at the top of said guides and at their bottoms to said carriage for stretching when said carriage is moved downward and for recoil to lift said carriage, a switch for said motor carried by said carriage, a pin carried by said guides adapted to turn said switch off when said carriage is at its uppermost position, a sleeve adjacent said base through which said drill needle rotatably extends for supporting said needle, an S-shaped member having a portion supporting said sleeve and another portion slidably mounted on said guides and supported on top of a compression spring supported on said boss, said sleeve being adapted to be engaged by said spindle to cushion downward movement of said carriage, and an adjustable stop for limiting the downward movement of said carriage including a split clamp slidably disposed on one of said guides, a ring slidably disposed on the other of said guides, means securing said clamp and ring on the opposite side of said guides from said motor, and a wing screw associated with said clamp for tightening same on its correlated guides, and a bolt extending loosely through said S-shaped member and compression spring and secured in said boss, limiting the upward movement of said S-shaped member by said compression spring.

6. A fabric drill for making marking holes in a pile of fabric, comprising a base, spaced cylindrical guides supported thereon, a plate spanning the tops of said guides and secured thereto, a carriage slidably mounted on said guides, including two spaced tubular spring housings and two tubular supports through which said guides slidably extend, and electric motor secured to said carriage having a spindle, a drill needle secured to said spindle for rotation thereby, tension springs in said housings, secured at their tops to said plate and at their bottoms to said housings for stretching when said carriage is moved down-

7

ward and for recoil to lift said carriage, a switch for said motor carried by said carriage, a pin carried by said guides adapted to turn said switch off when said carriage is at its uppermost position, a sleeve adjacent said base through which said drill needle rotatably extends for supporting said needle, said sleeve being supported on top of a compression spring supported on said base and being adapted to be engaged by said spindle to cushion downward movement of said carriage, and an adjustable stop for limiting the downward movement of said carriage including a split clamp slidably disposed on one of said guides, a ring slidably disposed on the other of said guides, means securing said clamp and ring on the opposite side of said guides from said motor, and a wing screw associated with said clamp for tightening same on its correlated guide.

7. A portable fabric drill for making marking holes in separate sheets of a pile of fabric, comprising a base, having a hole for a needle and an opening extending from said hole, spaced guides supported thereon, a manually-actuated carriage slidably mounted on said guides, lateral handles secured to said carriage for moving said carriage downward, an electric motor secured to said carriage having a spindle, a drill needle secured to said spindle for rotation thereby, tension springs secured at their tops at the top of said guides and at their bottoms to said carriage for stretching when said carriage is moved downward and for recoil to lift said carriage, a switch for said motor carried by said carriage, a pin carried by said guides adapted to turn said switch off when said carriage is at its uppermost position, a sleeve adjacent said base through which said drill needle rotatably extends for supporting said needle, said sleeve being supported on top of a compression spring supported on said base and being adapted to be engaged by said

8

spindle to cushion downward movement of said carriage, and an adjustable stop for limiting the downward movement of said carriage including a split clamp slidably disposed on one of said guides, a ring slidably disposed on the other of said guides, means securing said clamp and ring on the opposite side of said guides from said motor, and a wing screw associated with said clamp for tightening same on its correlated guide.

8. A fabric drill for making marking holes in a pile of fabric, comprising a base, spaced guides supported thereon, a carriage slidably mounted on said guides, an electric motor secured to said carriage having a spindle, a drill needle secured to said spindle for rotation thereby, tension springs secured at their tops at the top of said guides and at their bottoms to said carriage for stretching when said carriage is moved downward and for recoil to lift said carriage, a switch for said motor carried by said carriage, a pin carried by said guides adapted to turn said switch off when said carriage is at its uppermost position, a sleeve adjacent said base through which said drill needle rotatably extends for supporting said needle, said sleeve being slidably connected to said guides and supported on top of a compression spring supported on said base and being adapted to be engaged by said spindle to cushion downward movement of said carriage, and an adjustable stop for limiting the downward movement of said carriage including a split clamp slidably disposed on one of said guides, a ring slidably disposed on the other of said guides, means securing said clamp and ring on the opposite side of said guides from said motor, and a wing screw associated with said clamp for tightening same on its correlated guide, and a set screw in said sleeve for locking said needle therein in any desired lowered position.

STANLEY WIDLARZ.