

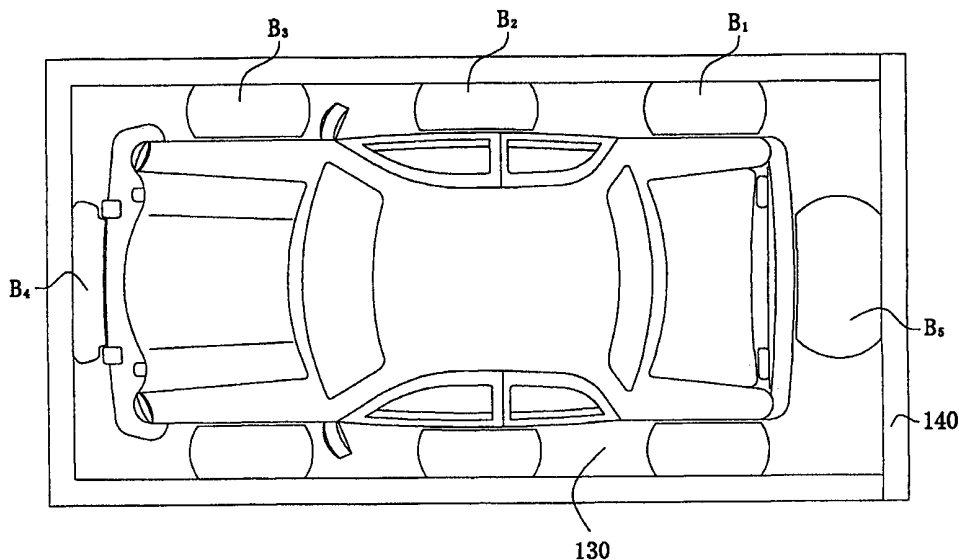

INTERNATIONAL APPLICATION PUBLISHED UNDER THE PATENT COOPERATION TREATY (PCT)

<p>(51) International Patent Classification ⁷ : A63G 31/16</p>	<p>A1</p>	<p>(11) International Publication Number: WO 00/13759 (43) International Publication Date: 16 March 2000 (16.03.00)</p>
<p>(21) International Application Number: PCT/JP99/04777 (22) International Filing Date: 2 September 1999 (02.09.99)</p> <p>(30) Priority Data: 09/149,030 8 September 1998 (08.09.98) US 09/385,852 30 August 1999 (30.08.99) US</p> <p>(71) Applicant: ORIENTAL SANGYO CO., LTD. [JP/JP]; 1-1-5, Hiranouemachi, Hiranoku, Osaka-shi, Osaka 547-0045 (JP). (72) Inventor: OCHI, Yasushi; 1-1-5, Hiranouemachi, Hiranoku, Osaka-shi, Osaka 547-0045 (JP). (74) Agent: ONO, Yukio; Ohtemae Century Building, 5-13, Katamachi 1-chome, Miyakojima-ku, Osaka-shi, Osaka 534-0025 (JP).</p>		<p>(81) Designated States: AU, CA, CN, JP, KR, European patent (AT, BE, CH, CY, DE, DK, ES, FI, FR, GB, GR, IE, IT, LU, MC, NL, PT, SE).</p> <p>Published <i>With international search report. Before the expiration of the time limit for amending the claims and to be republished in the event of the receipt of amendments.</i></p>

(54) Title: AMUSEMENT PARK WITH PASSENGER VEHICLE CARRYING RIDES



(57) Abstract

An amusement park includes a plurality of rides, each ride being provided with car support mechanisms. Each car support mechanism is configured to receive and support an automotive vehicle filled with at least one passenger. Further, a cable driver ride includes at least one carriage configured to receive and support a motorized passenger vehicle filled with at least one passenger and move with a cable as the cable is moved between at least one terminal and a tower, the cable extending therebetween.

FOR THE PURPOSES OF INFORMATION ONLY

Codes used to identify States party to the PCT on the front pages of pamphlets publishing international applications under the PCT.

AL	Albania	ES	Spain	LS	Lesotho	SI	Slovenia
AM	Armenia	FI	Finland	LT	Lithuania	SK	Slovakia
AT	Austria	FR	France	LU	Luxembourg	SN	Senegal
AU	Australia	GA	Gabon	LV	Latvia	SZ	Swaziland
AZ	Azerbaijan	GB	United Kingdom	MC	Monaco	TD	Chad
BA	Bosnia and Herzegovina	GE	Georgia	MD	Republic of Moldova	TG	Togo
BB	Barbados	GH	Ghana	MG	Madagascar	TJ	Tajikistan
BE	Belgium	GN	Guinea	MK	The former Yugoslav Republic of Macedonia	TM	Turkmenistan
BF	Burkina Faso	GR	Greece	ML	Mali	TR	Turkey
BG	Bulgaria	HU	Hungary	MN	Mongolia	TT	Trinidad and Tobago
BJ	Benin	IE	Ireland	MR	Mauritania	UA	Ukraine
BR	Brazil	IL	Israel	MW	Malawi	UG	Uganda
BY	Belarus	IS	Iceland	MX	Mexico	US	United States of America
CA	Canada	IT	Italy	NE	Niger	UZ	Uzbekistan
CF	Central African Republic	JP	Japan	NL	Netherlands	VN	Viet Nam
CG	Congo	KE	Kenya	NO	Norway	YU	Yugoslavia
CH	Switzerland	KG	Kyrgyzstan	NZ	New Zealand	ZW	Zimbabwe
CI	Côte d'Ivoire	KP	Democratic People's Republic of Korea	PL	Poland		
CM	Cameroon	KR	Republic of Korea	PT	Portugal		
CN	China	KZ	Kazakistan	RO	Romania		
CU	Cuba	LC	Saint Lucia	RU	Russian Federation		
CZ	Czech Republic	LI	Liechtenstein	SD	Sudan		
DE	Germany	LK	Sri Lanka	SE	Sweden		
DK	Denmark	LR	Liberia	SG	Singapore		
EE	Estonia						

DESCRIPTION**TITLE OF THE INVENTION**

AMUSEMENT PARK WITH PASSENGER VEHICLE CARRYING RIDES

5 **BACKGROUND OF THE INVENTION**

A. FIELD OF THE INVENTION

The present invention relates to amusement park rides which use passenger vehicles as a means for carrying persons on amusement rides.

10 B. DESCRIPTION OF THE RELATED ART

Traditionally, amusement parks have a variety of rides. In particular, rides such as Ferris wheels and roller coasters typically have carriages or carts permanently mounted on supports in the ride, including seats to accommodate thrill seekers. For instance, on a Ferris wheel, a series of pivoting carriages with seats are mounted about the outer periphery of the Ferris wheel. Thrill seekers are seated in the seats and the Ferris wheel rotates lifting the thrill seekers up to view local scenery and the like. Roller coasters typically have a car mounted on tracks. The car includes several seats and restraining devices, such as seat belts, or harnesses, which restrain the thrill seeker as the car rides on the tracks.

25 Amusement parks are very popular. One of many problems most people experience while visiting an

amusement park is the enormous amount of walking between rides and attractions. Another big problem with amusement parks is that the more popular rides have long lines of people waiting to enjoy the ride. People must stand and wait for extended periods of time, with little in the way of comforts or leisurely pleasures. Standing and waiting detracts from the enjoyment of the amusement park.

SUMMARY OF THE INVENTION

One object of the present invention is to make amusement parks more attractive by providing thrill seekers with a more comfortable way to travel between rides and wait in line for those rides.

Another object of the present invention is to provide the comforts of modern passenger automobiles in amusement park rides.

Yet another object of the present invention is to make amusement parks more attractive by providing thrill seekers with a more comfortable way to travel between rides and wait in line for those rides.

In accordance with the present invention, an amusement park includes at least one amusement ride. The amusement ride includes a plurality of a car support mechanisms. Each of the car support mechanisms is configured to receive and support an automotive vehicle with passengers inside and the amusement ride is

configured to move the plurality of car support mechanisms in accordance with the thrills of the amusement ride.

Preferably, the amusement ride is a roller coaster.

5 Preferably, the car support mechanism includes a front and a rear gate which secure the automotive vehicle thus preventing movement of the automotive vehicle with respect to the car supporting mechanism.

Preferably, the amusement ride is an adventure theater.

10 Preferably, the car support mechanism includes a mechanism for restraining movement of the tires of the automotive vehicle.

Preferably, the amusement ride is a saucer tea cup ride.

15 Preferably, the amusement ride is a swing ride.

Preferably, the amusement ride is a ferris wheel.

20 Preferably, each of the car support mechanisms includes a platform and front and rear gates supported on the platform. The front and rear gates are configured to secure the automotive vehicle to platform thus preventing movement of the automotive vehicle with respect to the car supporting mechanism. The platform is further provided with a plurality of rollers which may be selectively braked against rolling movement.

25 Alternatively, the car support mechanism includes a

generally flat platform upon which an automobile is positionable. The car support mechanism also includes at least two generally upright sides extending from the platform and at least one inflatable bag that is fixed to at least one of the upright sides. Upon inflation, the inflatable bag is configured to engage and secure the automotive vehicle on the platform.

Preferably, the car supporting mechanism includes a gate mounted to the platform. The gate includes a second inflatable bag.

Preferably, the car support mechanism includes means for supporting the platform on an underside thereof for use on the amusement ride and the amusement ride is configured with tracks for receiving the support means.

Alternatively, the car support mechanism includes means for supporting the platform on an upperside thereof for use on the amusement ride. The amusement ride including means for lifting the platform from an upper side thereof.

Alternatively, the car support mechanism may include a generally flat platform upon which an automobile is positionable and at least one first inflatable bag fixed to the platform. The first inflatable bag is configured to engage and secure the automotive vehicle on the platform by preventing wheels of the automotive vehicle

from rotating.

Preferably, a second inflatable bag is fixed to the platform proximate a rearward side of the automotive vehicle and the first inflatable bag is positioned proximate a forward side of the automotive vehicle.

Preferably, the car support mechanism further includes a means for contacting an upper surface of the automotive vehicle for restraining upward movement of the automotive vehicle.

In accordance with another aspect of the present invention, a cable driven ride includes at least one supporting tower, at least one terminal spaced apart from the supporting tower and a cable extending between the tower and the terminal. The cable is supported by the tower such that the cable is continuously moveable between the tower and the terminal. A means for moving the cable between the tower and the terminal is provided in the terminal. At least one carriage is engagable with the cable such that the carriage is moveable with the cable between the tower and the terminal. The carriage is configured to support and carry a motorized passenger vehicle.

Preferably, the carriage includes a front gate which secures the motorized passenger vehicle thus preventing movement of the motorized passenger vehicle with respect to the carriage.

Preferably, the carriage includes a platform and front and rear gates supported on the platform, the front and rear gates being configured to secure the motorized passenger vehicle to the platform thus preventing movement
5 of the motorized passenger vehicle with respect to the carriage, and the platform being further provided with a plurality of rollers which may be selectively braked against rolling movement.

Preferably, the carriage includes a generally flat
10 platform upon which an automobile is positionable and at least two generally upright sides extending from the platform. At least one inflatable bag is fixed to at least one of the upright sides and upon inflation the inflatable bag engages and secures the motorized passenger
15 vehicle on the platform.

Preferably, a gate mounted to the platform, the gate including a second inflatable bag.

These and other objects, features, aspects and advantages of the present invention will become more fully
20 apparent from the following detailed description of the present invention when taken in conjunction with the accompanying drawings where like reference numerals denote corresponding parts throughout.

BRIEF DESCRIPTION OF THE DRAWINGS

25 Fig. 1 is a schematic representation of a first section of an amusement park having a variety of rides in

accordance with one embodiment of the present invention;

Fig. 2 is a schematic representation of a second section of the amusement park having further rides in accordance with one embodiment of the present invention;

5 Fig. 3 is a schematic representation of a saucer tea cup ride having car supporting mechanisms;

Fig. 4 is an adventure theater having car supporting mechanisms;

10 Fig. 5 a car support mechanism used in the rides in the amusement park;

Fig. 6 is a fragmentary side view of the car support mechanism depicted in Fig. 5;

Fig. 7 is another car support mechanism;

15 Fig. 8 is a fragmentary side view of the car support mechanism depicted in Fig. 7;

Fig. 9 is another car support mechanism;

Fig. 10 is another car support mechanism;

Fig. 11 is yet another support mechanism for use in the amusement park;

20 Fig. 12 is a perspective view of yet another support mechanism for use in the amusement park, where the support mechanism includes inflatable support bags;

Fig. 13 is a control system for controlling the inflatable support bags depicted in Fig. 12;

25 Fig. 14 is a top view of the support mechanism depicted in Fig. 12, with an automotive vehicle being

restrained therein;

Fig. 15 is a top view of an alternate configuration of the support mechanism depicted in Fig. 12;

5 Fig. 16 is a perspective view of the support mechanism depicted in Fig. 12 having track support on an underside thereof;

Fig. 17 is a perspective view of the support mechanism depicted in Fig. 12 having support on an upperside thereof;

10 Fig. 18 is a perspective view of still another support mechanism in accordance with the present invention, where the support mechanism includes inflatable bags;

15 Fig. 19 is a perspective view of the support mechanism depicted in Fig. 18, with the inflatable bags in an inflated state;

20 Fig. 20 is a perspective view of a support mechanism similar to that depicted in Figs. 18 and 19 where the support mechanism further includes an upper support mechanism;

Fig. 21A is a side view of a cable driven ride in accordance with the present invention;

25 Fig. 21B is a perspective view of the cable driven ride that moves carriages, each carriage carrying a motorized passenger vehicle;

Fig. 22 is perspective view of a carriage supported

on a cable of the cable driven ride depicted in Fig. 21;

Fig. 23 is a side view of portions of a terminal of the cable driven ride depicted in Figs. 21 and 22, the terminal for loading and unloading motorized passenger vehicles from a carriage;

Fig. 24 is a top view of a portion of the terminal depicted in Fig. 23;

Fig. 25 is a perspective view of the portion of the terminal depicted in Fig. 24;

Fig. 26 is a perspective view of one embodiment of the carriage of the cable driven ride depicted in Figs. 21-25;

Fig. 27 is a fragmentary top view of the carriage depicted in Fig. 26;

Fig. 28 is a fragmentary top view similar to Fig. 27 showing an alternate embodiment of the carriage depicted in Fig. 27;

Fig. 29 is a fragmentary perspective view of another embodiment of the carriage of the cable driven ride; and

Fig. 30 is a fragmentary side view of a portion of the carriage depicted in Fig. 29.

DETAILED DESCRIPTION OF THE PREFERRED EMBODIMENTS

Fig. 1 is a schematic representation of a first section of an amusement park having a variety of rides in accordance with one embodiment of the present invention. The rides include a pirate boat ride 2, a looping boat

ride 4, a saucer tea cup ride 5, a roller coaster ride 8 and a Ferris wheel ride. In Fig. 2, a second section of the amusement park is shown having swing ride 12, a water flume ride 15 and an adventure theater 20.

5 Each of the rides includes an entrance and an exit and corresponding loading and unloading areas. For instance, the roller coaster ride 8 includes a loading zone 8a and an unloading zone 8b. Likewise, the swing ride 12 has a loading zone 12a and an unloading zone 12b,
10 and the water flume ride 15 has a loading zone 15a and an unloading zone 15b.

 Each of the above mentioned rides is configured to receive and secure automotive vehicles such as the vehicle V shown in Fig. 5. Each ride is therefore provided with a
15 plurality of car supporting mechanisms 25, such as the car supporting mechanisms 25 shown in Fig. 3 on the saucer tea cup ride 5. The saucer tea cup ride 5 includes a large saucer 5a which is connected to a large motor (not shown) such that the large saucer 5a may be rotated about a
20 central axis thereof. Within the structure of the large saucer 5a are four intermediate saucers 5b which are each provided with power to rotate about a central axis thereof while the large saucer 5a is rotated. Further, each intermediate saucer 5b has four small saucers 5c which
25 rotate about a central axis thereof while the saucers 5a and 5b are rotated. Each small saucer 5c includes four

car supporting mechanisms 25, which are described in greater detail below.

In Fig. 4, an adventure theater 20 is depicted. The adventure theater 20 includes a platform supported by a plurality of pressure controlled cylinders such that the platform may be moved in accordance with images projected on a screen. The theater 20 includes an on ramp 20a and an off ramp 20b. The theater 20 is also provided with a plurality of car supporting mechanisms 25.

Figs. 5 through 11 depict various types of a car support mechanisms 25 used in the rides in the amusement park. Each ride in the amusement park has its own dynamics, each with different requirements for securing an automotive vehicles safely during the ride.

In Figs. 5 and 6, the car support mechanism includes a platform 30 that includes a support bar 31 which may be made of a strong metal material coated with soft foam material to protect against contact with the car V. A swinging rear gate 32 is moveable up and down as indicated by the Arrow A and powered by a pressure cylinder (not shown).

In the front portion of the platform 30 there are two parallel sliding bars 35 (although only one bar 35 is visible). The sliding bar 35 is secured to the platform 30 but may slide along the pins 36. The sliding movement of the bar 35 is limited by the length of an elongated

groove 35a. Movement of the bar 35 is controlled by a pressure cylinder 40 that is secured at one end to the platform 30 and secured to the bar 35 at the other end. A front gate 42 is pivotally mounted to the bar 35.

5 Movement of the front gate 42 is controlled by a cylinder 43.

The platform 30 is further provided with a plurality of rollers 45. The rollers 45 are all generally parallel within the platform 30 and are freely rotatable. A
10 braking mechanism (not shown) is mounted within the platform 30 for selectively restricting the rolling movement of the rollers 45.

The car supporting mechanism depicted in Figs. 5 and 6 operates as follows. When a car is to be loaded on the
15 car supporting mechanism, the rear gate 32 is lowered and the bar 35 is moved to a forward most position. The brake mechanism (not shown) is engaged such that the rollers 45 may not rotate within the platform 30. A car V is then driven onto the platform 30 and the rollers 45. Once the
20 car V is in position, the rear gate 32 is raised and the front gate 42 is moved toward the front of the car V by positioning the sliding bar 35. It should be noted that the front and rear gates 42 and 32 are lined with a soft material such as foam in order to protect the car V from
25 damage in the event of contact therebetween.

Next, the brake mechanism (not shown) is disengaged

such that the rollers 45 may rotate freely within the platform 30. In this situation, the car V is secured within the car support mechanism 25 but may not move due to the front and rear gates 42 and 32. Further, in the event that the motor of the car V is running and the driver accidentally presses on the accelerator, there is no risk of damage to the car V since the rollers 45 may rotate freely. Since the tires of the car V are engaged with the rollers 45, there is no danger of the car V leaving the car supporting mechanism 25 depicted in Figs. 5 and 6.

The car support mechanism 25 depicted in Figs. 5 and 6 is suitable for most of the rides in the amusement park but is particularly suitable for the boat rides 2 and 4 and for the roller coaster ride 8. A car can be driven easily onto the car supporting mechanism 25 and the car supporting mechanism moves in the amusement ride with the passengers of the car V in relative safety.

Another car support mechanism is depicted in Figs. 7 and 8. In this mechanism, a car V is driven onto a platform 60 until the car V is approximately positioned adjacent to openings 60a. Once positioned, arms 61 are moved upward on either side of each tire of the car V. Next, the arms 61 can be moved toward one another until engaged with the tire. The movement of the arms 61 is controlled by the cylinders 62 and 63. Once engaged with

the tires, the arms 61 securely hold the car V in position on the platform 60. Such a configuration of the car support mechanism may be used on, for instance, the saucer tea cup ride 5.

5 A further car support mechanism is depicted in Fig. 9 where an arm 65 is extendable upward out of a platform 66.

 The car support mechanisms 25 are supported in the rides in various ways. For instance, in both the roller coaster ride 8 and the water flume ride 15, the car
10 support mechanism 25 is supported on rails R by support structures fixed to a lower portion of the car support mechanism 25, where the support structures include a plurality of wheels which engage the rails R. As shown in Fig. 10, the rails may be submerged under water.

15 Rides such as the Ferris wheel 10 and the swing 12 require a car support mechanism 25 such as that depicted in Fig. 11. The car support mechanism 25 depicted in Fig. 11 includes the rollers 45, the front and rear gates 42 and 32 and a support structures 70 and 75 which allow for
20 the car V to be lifted up. For instance, in the swing ride 12, the cars would be driven onto the platforms of the car support mechanism 25 depicted in Fig. 11, then the central support of the swing ride 12 moves upward, the car support mechanisms are lifted off the ground and swung
25 slowly around. The Ferris wheel 10, on the other hand, lifts the car support mechanisms off the ground as the

Ferris wheel rotates.

Another embodiment of a car support mechanism is depicted in Figs. 12, 13 and 14. The car support mechanism includes a platform 130. The platform 130 includes upright sides 135 on three sides thereof. The sides 135 are formed with a plurality of recesses 136. Within each recess 136 is an inflatable bag, such as the bags B_1 , B_2 , B_3 , B_4 and B_5 . There are additional bags, not shown in Fig. 12, as is explained in greater detail below with regard to Fig. 14. The bags B_1 , B_2 , B_3 , B_4 and B_5 are sealed bags made of a durable air tight material and may include various plies in order to provide an air tight seal. The outer ply of the bags B_1 , B_2 , B_3 , B_4 and B_5 is soft so that it is unlikely that the outer surface of the bags B_1 , B_2 , B_3 , B_4 and B_5 can harm painted surfaces, such as the surfaces of an automobile.

Although not shown in Fig. 12, the bags B_1 , B_2 , B_3 , B_4 and B_5 are connected to an inflation control system 150, as is depicted in Fig. 13. The inflation control system 150 includes a controller 155 that is connected to a valve/sensor control 156. The valve/sensor control 156 is in turn connected to a compressed air tank 157 that is supplied with compressed air from a compressor 158.

The valve/sensor control 156 includes a plurality of valves, each valve for selectively supplying compressed air to the bags B_1 , B_2 , B_3 through B_N . The bag B_N is not

depicted but is rather a representation of all the inflatable bags that may be included in the present invention. Each valve is controlled by the controller 155. Each valve includes a sensor (not shown) for sensing the air pressure in each bags B_1 , B_2 , B_3 through B_N .

As is shown in Fig. 14, the car support mechanism depicted in Fig. 12 includes a total of eight (8) inflatable bags, including bags B_1 , B_2 , B_3 and B_5 . Each bag is inflatable to a predetermined pressure for securing an automobile on the platform 130.

The platform 130 includes a gate 140 on which the bag B_5 is secured. With the gate 140 in a lowered position, as is depicted in Fig. 12, an automobile may be driven onto the platform 130, as is shown in Fig. 14. Once the automobile is in position on the platform 130, the gate 140 is raised and an operator may manipulate controls on the controller 155 causing the bags, including bags B_1 , B_2 , B_3 and B_5 to inflate. In an inflated condition, the bags engage the sides, front and rear of the automobile securely retaining the automobile on the platform 130.

The sensors (not shown) associated with the valves in the valve/sensor control 156 may be used to monitor the pressure within the bags B_1 , B_2 , B_3 and B_N . The pressure within the bags provides an indication of engagement with the automobile. Therefore, if the bags are inflated to a predetermined air pressure, it can be determined that the

automobile is secured on the platform 130. The amusement ride utilizing the platform 130 can safely commence with the automobile safely in position on the platform 130. After completion of the ride, the operator may manipulate controls (not shown) on the controller 155 to release the pressure from the inflatable bags out an exhaust 159 so that the bags may retract into the recesses 136, the gate 140 may drop down and the automobile drive out to the next ride.

10 As should be apparent from Fig. 14, the doors of the automobile are secured against opening by the inflatable bags in contact with the sides of the automobile, further adding to the safety of the car support mechanism depicted in Figs. 12, 13 and 14.

15 It should be understood that the platform 130 may be provided with any of a variety bag configurations. For instance, as is shown in Fig. 15, there may only four (4) bags, bags B_{1a} , B_{2a} , B_{3a} and B_{5a} on the platform 130. Other combinations of inflatable bags and sizes of inflatable bags are of course possible.

20 The platform 130 may be configured in a variety of ways for use on a variety of amusement rides. For instance, as shown in Fig. 16, the platform 130 may be configured for a ride which supports the platform 130 on rails R_1 and R_2 . Or, alternatively, the platform 130 may be supported from above, as depicted in Fig. 17, for use

on the swing 12 or the Ferris Wheel 10.

Yet another embodiment of the present invention is depicted in Figs. 18 and 19. A support mechanism having a platform 230 is formed with a plurality of recesses 235.

5 In each recess 235 there is disposed an inflatable bag 240. The inflatable bags 240 are similar to the bags B_1 , B_2 , B_3 through B_N described above. Although not shown in Figs. 18 and 19, a control system, such as the control system depicted in Fig. 13 is used to control the
10 inflation condition of the bags 240.

As is shown in Fig. 19, the bags 240 are inflatable for securing an automotive vehicle V to the platform 230. It should be appreciated that the platform 230 depicted in Figs. 18 and 19 is provided with at least four bags 240,
15 although only three bags 240 are visible. One bag 240 is positioned on each side of the platform 230 corresponding to sides of the automotive vehicle V. One bag 240 is positioned forward from front wheels of the automotive vehicle V and one bag 240 is positioned rearward from rear
20 wheels of the automotive vehicle V.

The positioning of the bags 240 on the platform 230 is such that the wheels of the automotive vehicle V are blocked against rotation with the bags 240 in an inflated state. Further, the bags 240 on either side of the
25 automotive vehicle V are positioned to engage doors of the automotive vehicle V thus preventing the doors from

opening with the bags 240 in an inflated state, as shown in Fig. 19.

Thus, the support mechanism depicted in Figs. 18 and 19 provides a reliable and safe way to restrain a vehicle on the platform 230 in a simple manner.

It should be appreciated that with the bags 240 in an uninflated state, the bags 240 retract into the recesses 235. The bags 240 are may be made of any of a variety of materials making in possible for the car to roll over the bags 240 when entering the platform 230 and leaving the platform 230.

In order to retract into the recesses 235, the bags 240 may be elastic or may have an elastic element or elements formed on an outside surface or within the bags 240.

For some amusement park rides, such as the roller coaster, it may be necessary to secure an automotive vehicle from above. In other words, upward movement of the vehicle relative to the platform must be avoided for safety reasons. In such a circumstance, it may be desirable to include a means for holding the vehicle against the surface of the platform of the support mechanism. Such a means is included in the support mechanism depicted in Fig. 20. The support mechanism depicted in Fig. 20 is generally the same as the support mechanism depicted in Figs. 18 and 19, except that the

upper support mechanism 260 is fixed to the platform 230.

The upper support mechanism 260 includes an upright support 261 fixed to the platform 230, a telescoping member 262 that extends upward from the upright support 261 and a support structure 263 which is fixed to the telescoping member 262. On a lower surface of the support structure 263 is a cushion 265. However, the cushion 265 could alternatively be an inflatable bag. The telescoping member 262 may be moved up and down by control means (not shown) such as a crank lever, a hydraulic or pneumatic cylinder or other such device. By moving the telescoping member 262, the cushion 265 may be brought into engagement with the roof of the automotive vehicle V, thus securing the automotive vehicle V against movement up and down relative to the platform 230.

The upper support mechanism 260 is not limited to the structure as shown. For instance, the upper support mechanism 260 could be used with any of the embodiments of the present invention. Further, the upper support mechanism 260 is not limited to a single upright support member. In some applications it may be desirable to utilize several support members in the upper support mechanism 260. Further, the telescoping member 262 need not be used. Rather the support structure 263 may be directly fixed to the upright support 261 and an inflatable bag may be used instead of a cushion. As well,

a sensor may be employed with a control system for automatically sensing the height of the automotive vehicle V and positioning the cushion 265 against the roof of the automotive vehicle V.

5 CABLE DRIVEN RIDE

In another embodiment of the present invention depicted in Figs. 21A-30, a cable driven ride is configured to support and move a plurality of carriages, each carriage able to support a motorized passenger vehicle. The cable driven ride may be used in, for instance, environmentally sensitive areas where the building of roads would intrude upon the local environment. Since people love to view nature from the comfort of their own car, the cable driven ride in accordance with the present invention provides a means for people to enjoy a ride through a valley or about a mountain side paradise without a road intruding upon the natural beauty of the scene.

As shown in Fig. 21A, the cable driven ride includes two terminals T and at least one tower 301, although a plurality of towers 301 may be utilized. Each tower includes rollers that may be protected by a cover 302, as shown in Fig. 21B, the rollers supporting a cable C and allowing the cable C to move with respect to the tower 301 as the cable is pulled between the terminals T. The cable C extends between a plurality of the towers 301 over

natural terrain. For instance the towers 301 may be spaced apart by a distance of hundreds of meters with the cable extending therebetween. The cable is moved between adjacent towers 301 such that the passenger vehicle moves
5 above a scenic view.

The cable C supports a plurality of carriages 325, each carriage 325 able to support an automotive vehicle in much the same way as the support mechanisms discussed above with respect to Figs. 1-20. Each carriage 325, as
10 shown in Figs. 21B, 22 and 23, includes at least one cable hook 330 that engages the cable C, thereby causing the carriages 325 to move along with the cable C. The cable hook 330 is part of a support assembly that also includes rollers 332. In the embodiment depicted in Figs. 21B and
15 22, the support assembly includes four rollers 332 and two cable hooks 330.

Each of the carriages 325, as shown in Figs. 21, 22 and 23, includes a frame structure that includes upright support beams 340, angled support beams 341 and a support
20 plate 342, all rigidly fixed to one another. The lower portion of the frame structure includes three side panels 343 and one gate 345, described further below.

The cable driven ride includes at least one terminal T, depicted in Figs. 23, 24 and 25. Each of the two
25 terminals T supports the cable as it rotates in an endless belt manner between the two terminals T. As shown in Fig.

23, each of the terminals includes a motor 350 and a pulley 351 that engages the cable C. As the motor 350 rotates, the cable C is moved along the rollers of the towers 301 thereby moving the carriages 325.

5 The terminal is also provided with a pair of tracks 360 and 361 that have a U-shape, as shown in a top view in Fig. 24. As is shown in Figs. 23 and 24, the tracks 360 and 361 are supported from above by supports 368. Portions 360a and 361a of the tracks 360 and 361 are positioned
10 adjacent to the cable C at points along the cable C just before the cable C engages the pulley 351 and just after the cable C leaves the pulley 351. As can be seen in Fig. 23, the portions 360a (and 361a) are bent such that they are slightly higher than the cable C.

15 As each of the carriages 325 enter the terminal T, the cable hooks 330 engaged with cable C. Movement of the cable C causes the rollers 332 to eventually contact the tracks 360 and 361. As the carriage 325 continues to move toward the pulley 351 with the cable C, the rollers 330
20 begin to roll over the portions 360a and 361a of the tracks 360 and 361. Therefore, the carriage is lifted up such that the cable hooks 330 are lifted away from contact with the cable C. Momentum keeps the carriages 325 rolling on the tracks 360 and 361 until the tracks engage
25 the portions 360b and 361b, which are bent away from the pulley, thereby causing the cable hooks 330 to be moved

away from the cable C. The carriage 325 is then able to roll to the arcuate portion of the tracks 360 and 361 above a platform 370.

5 The platform 370 is supported by a plurality of cylinders 372 that allow upward and downward movement of the platform 370. The cylinders 372 may be either hydraulic, pneumatic or electric devices which provide controllable movement of the platform 370.

10 Once the carriage 325 has moved under the platform 370, the platform is raised to support the carriage 325 to prevent it from moving as a motorized passenger vehicle is moved in and out of the carriage 325. With the platform 370 supporting the carriage 325, the gate 345 may then be lowered and a ramp 375 shown in Fig. 25 may be moved to a
15 position adjacent to the platform 370 and gate 345 to allow a motorized passenger vehicle to move in or out of the carriage 325. After a motorized passenger vehicle has been loaded on to the carriage 325, the gate 345 may be closed, the ramp 375 moved out of the way, and the
20 platform 370 lowered out of the way. Due to the presence of the rollers 332 being engaged with the tracks 360 and 361, the carriage 325 is easily pushed either by manual operators along the tracks 360 and 361 to the portions 360b and 361b of the tracks, and subsequently to the
25 portions 360a and 360b. Once the cable hooks 330 contact the cable C, the carriage 325 then moves with the cable C

and the roller 332 become dis-engaged from the tracks 360 and 361.

It should be understood that Fig. 25 does not show the motor 350 or the supports 368 in order to provide
5 greater clarity of the various features of the present invention.

It should also be understood that the carriage 325 described above is basically a cage which supports a motorized vehicle in the cable driven ride. There are
10 many different sizes, shapes and configurations of motorized passenger vehicles and therefore, ideally, the carriages 325 should be able to accommodate as many different types of vehicles as possible. For that reason, several embodiments of the carriages 325 are contemplated.

One such carriage 380 is shown in Figs. 26 and 27. The carriage 380 includes an open structure similar to the carriage 325. For instance the carriage 380 includes the supports beams 340 and 341, as well as the gate 345 and side panels 343. However, the carriage 380 also includes
15 a plurality of inflatable bags B_1, B_2, B_3 through B_N , similar to the bags described above with respect to Figs. 12, 13 and 14. The bags B_1, B_2, B_3 through B_N surround a motorized passenger vehicle, as shown in Fig. 27, thereby securing the motorized passenger vehicle within the
20 carriage 380.

The bags B_1, B_2, B_3 through B_N may be inflated by any

of a variety of means. For instance, a single air inlet/outlet I/O may be provided on the carriage 380 and connected to each of the bags B_1 , B_2 , B_3 and B_N via pressure tubes (not shown). An operator may inflate the bags using pressurized air before launching the carriage 380 on the cable C via the tracks 360 and 361. An air compressor (not shown) and air supply hose (not shown) are provided in the terminal adjacent to the platform 370 for inflating the bags B_1 , B_2 , B_3 through B_N . The bags B_1 , B_2 , B_3 through B_N are deflated by releasing the air pressure via the inlet/outlet I/O.

Alternatively, the platform 380 may be provided with fewer bags, each bag being larger than the bags shown in Fig. 27. For instance, bags B_{1a} , B_{2a} , B_{3a} and B_{4a} may be provided on the side panels of the platform 380 as shown in Figs. 28. The bags B_{1a} , B_{2a} , B_{3a} and B_{5a} may be inflated and deflated via an inlet/outlet I/O that is connected via pressure tubes (not shown) to each of the bags B_{1a} , B_{2a} , B_{3a} and B_{5a} .

A carriage 400 is also contemplated. The carriage 400 is depicted in Figs. 29 and 20 and includes a gate 42 the car support mechanism includes a platform and support structure that includes a support bar 31 which may be made of a strong metal material coated with soft foam material to protect against contact with the motorized passenger vehicle. A swinging rear gate 32 is moveable up and down.

In the front portion of the platform there are two parallel sliding bars 35 (although only one bar 35 is visible). The sliding bar 35 is secured to the platform but may slide along the pins 36. The sliding movement of the bar 35 is limited by the length of an elongated groove 35a. Movement of the bar 35 is controlled by a pressure cylinder 40 that is secured at one end to the platform and secured to the bar 35 at the other end. A front gate 42 is pivotally mounted to the bar 35. Movement of the front gate 42 is controlled by a cylinder 43.

The cylinders 40 and 43 include a locking mechanism (not shown) such that after being put into position, if air pressure is reduced, the cylinders 40 and 43 are locked into position until air pressure within the cylinders is restored. In this manner, the cylinders 40 and 43 may only be moved when air pressure is supplied by an operator in the terminal. Therefore, while moving with the cable in the cable driven ride, the carriage 400 safely retains the motorized vehicle.

The platform 30 is further provided with a plurality of rollers 45. The rollers 45 are all generally parallel within the platform 30 and are freely rotatable. A braking mechanism (not shown) is mounted within the platform 30 for selectively restricting the rolling movement of the rollers 45. Specifically, the rollers 45 may only be locked and unlocked by an operator at the

terminal to allow the motorized vehicle to enter and leave the carriage 400.

The carriage depicted in Figs. 29 and 30 operates as follows. When a car is to be loaded on the carriage 400, the rear gate 32 is lowered and the bar 35 is moved to a forward most position by an operator at the terminal. The brake mechanism (not shown) is engaged such that the rollers 45 may not rotate within the platform 30. A motorized passenger vehicle is then driven onto the carriage 400 and the rollers 45. Once the motorized passenger vehicle is in position, the rear gate 32 is raised and the front gate 42 is moved toward the front of the motorized passenger vehicle by an operator who uses air pressure from an air hose (not shown) to position the sliding bar 35 and front gate 42. It should be noted that the front and rear gates 42 and 32 are lined with a soft material such as foam in order to protect the motorized passenger vehicle from damage in the event of contact therebetween.

Next, the brake mechanism (not shown) is disengaged such that the rollers 45 may rotate freely within the platform 30. In this situation, the motorized passenger vehicle is secured within the car support mechanism 25 but may not move due to the front and rear gates 42 and 32. Further, in the event that the motor of the motorized passenger vehicle is running and the driver accidentally

presses on the accelerator, there is no risk of damage to the motorized passenger vehicle since the rollers 45 may rotate freely. Since the tires of the motorized passenger vehicle are engaged with the rollers 45, there is no
5 danger of the motorized passenger vehicle leaving the platform 400.

The cable driven ride described above is ideal for areas that have difficult terrain to drive over or that are protected against development. For instance, the cable
10 driven ride may be used in mountainous areas or wilderness areas where roads are either intrusive or difficult and costly to build. Since the cable driven ride may pass above such areas, there is little if any intrusion by the motorized passenger vehicle on the environment because the
15 motorized passenger vehicles do not need a road and do not necessarily have their motors running while on the cable driven ride.

The cable driven ride may alternatively be what is often referred to as a cable car ride where there are only
20 two carriages employed. The carriages are fixed to the cable such that when the first carriage is in a first terminal, the second carriage is located in the second terminal. The two carriages move toward one another as the cable rotates between the terminals. The two
25 carriages pass one another and continue moving toward the opposite terminal. In such a configuration, the ramp 375

and tracks 360 and 361 would not be necessary since the cable must stop moving as the cars approach the terminals. The carriages are unloaded simultaneously. In other words, when the first carriage moves toward the second carriage, the second carriage moves in the opposite direction towards the first carriage. The two carriages trade places going back and forth between the two terminal. The present invention is intended to apply to such a cable car ride.

Various details of the invention may be changed without departing from its spirit nor its scope. Furthermore, the foregoing description of the embodiments according to the present invention is provided for the purpose of illustration only, and not for the purpose of limiting the invention as defined by the appended claims and their equivalents.

CLAIMS

1. An amusement park comprising:

at least one amusement ride, said amusement ride including a plurality of a car support mechanisms, wherein each of said car support mechanisms is configured to receive and support an automotive vehicle with passengers inside and said amusement ride is configured to move said plurality of car support mechanisms in accordance with the thrills of said amusement ride.

2. The amusement park as set forth in claim 1, wherein said amusement ride is a roller coaster.

3. The amusement park as set forth in claim 2 wherein said car support mechanism includes a front and a rear gate which secure the automotive vehicle thus preventing movement of the automotive vehicle with respect to the car supporting mechanism.

4. The amusement park as set forth in claim 1, wherein said amusement ride is an adventure theater.

5. The amusement park as set forth in claim 4 wherein said car support mechanism includes a mechanism for restraining movement of the tires of the automotive vehicle.

6. The amusement park as set forth in claim 1, wherein said amusement ride is a saucer tea cup ride.

7. The amusement park as set forth in claim 1,

wherein said amusement ride is a swing ride.

8. The amusement park as set forth in claim 1,
wherein said amusement ride is a Ferris wheel.

5 9. The amusement park as set forth in claim 1,
wherein each of said car support mechanisms includes a
platform and front and rear gates supported on said
platform, said front and rear gates being configured to
secure the automotive vehicle to said platform thus
preventing movement of the automotive vehicle with respect
10 to the car supporting mechanism, and said platform being
further provided with a plurality of rollers which may be
selectively braked against rolling movement.

10. The amusement park as set forth in claim 1
wherein said car support mechanism comprises:

15 a generally flat platform upon which an automobile is
positionable;

at least two generally upright sides extending from
said platform; and

20 at least one inflatable bag being fixed to at least
one of said upright sides, upon inflation, said inflatable
bag being configured to engage and secure the automotive
vehicle on said platform.

11. The amusement park as set forth in claim 10,
said car supporting mechanism further comprising a gate
25 mounted to said platform, said gate including a second

inflatable bag.

12. The amusement park as set forth in claim 11,
wherein said car support mechanism includes means for
supporting said platform on an underside thereof for use
5 on said amusement ride, said amusement ride being
configured with tracks for receiving said support means.

13. The amusement park as set forth in claim 11,
wherein said car support mechanism includes means for
supporting said platform on an upperside thereof for use
10 on said amusement ride, said amusement ride including
means for lifting said platform from an upper side
thereof.

14. The amusement park as set forth in claim 1
wherein said car support mechanism comprises:

15 a generally flat platform upon which an automobile is
positionable;

at least one first inflatable bag being fixed to said
platform, said first inflatable bag being configured to
engage and secure the automotive vehicle on said platform
20 by preventing wheels of the automotive vehicle from
rotating.

15. The amusement park as set forth in claim 14
wherein said car support mechanism further comprises:

a second inflatable bag fixed to said platform
25 proximate a rearward side of the automotive vehicle and

said first inflatable bag being positioned proximate a forward side of the automotive vehicle.

16. The amusement park as set forth in claim 15 wherein said car support mechanism further comprises a means for contacting an upper surface of the automotive vehicle for restraining upward movement of the automotive vehicle.

17. The amusement park as set forth in claim 1 wherein each of said car support mechanisms further comprises a means for contacting an upper surface of the automotive vehicle for restraining upward movement of the automotive vehicle with respect to the car support mechanism.

18. An cable driven ride comprising:

at least one supporting tower;

at least one terminal spaced apart from said supporting tower;

a cable extending between said tower and said terminal, said cable being supported by said tower such that said cable is continuously moveable between said tower and said terminal;

a means for moving said cable between said tower and said terminal;

at least one carriage engagable with said cable such that said carriage is moveable with said cable between said tower and said terminal; and

said carriage is configured to support and carry a motorized passenger vehicle.

19. The cable driven ride as set forth in claim 18 wherein said carriage includes a front gate which secures
5 the motorized passenger vehicle thus preventing movement of the motorized passenger vehicle with respect to the carriage.

20. The cable driven ride as set forth in claim 18 wherein said carriage includes a platform and front and
10 rear gates supported on said platform, said front and rear gates being configured to secure the motorized passenger vehicle to said platform thus preventing movement of the motorized passenger vehicle with respect to the carriage,
and said platform being further provided with a plurality
15 of rollers which may be selectively braked against rolling movement.

21. The cable driven ride as set forth in claim 18 wherein said carriage comprises:

a generally flat platform upon which an automobile is
20 positionable;

at least two generally upright sides extending from said platform; and

at least one inflatable bag being fixed to at least one of said upright sides, upon inflation, said inflatable
25 bag being configured to engage and secure the motorized passenger vehicle on said platform.

22. The cable driven ride as set forth in claim 21, said carriage further comprising a gate mounted to said platform, said gate including a second inflatable bag.

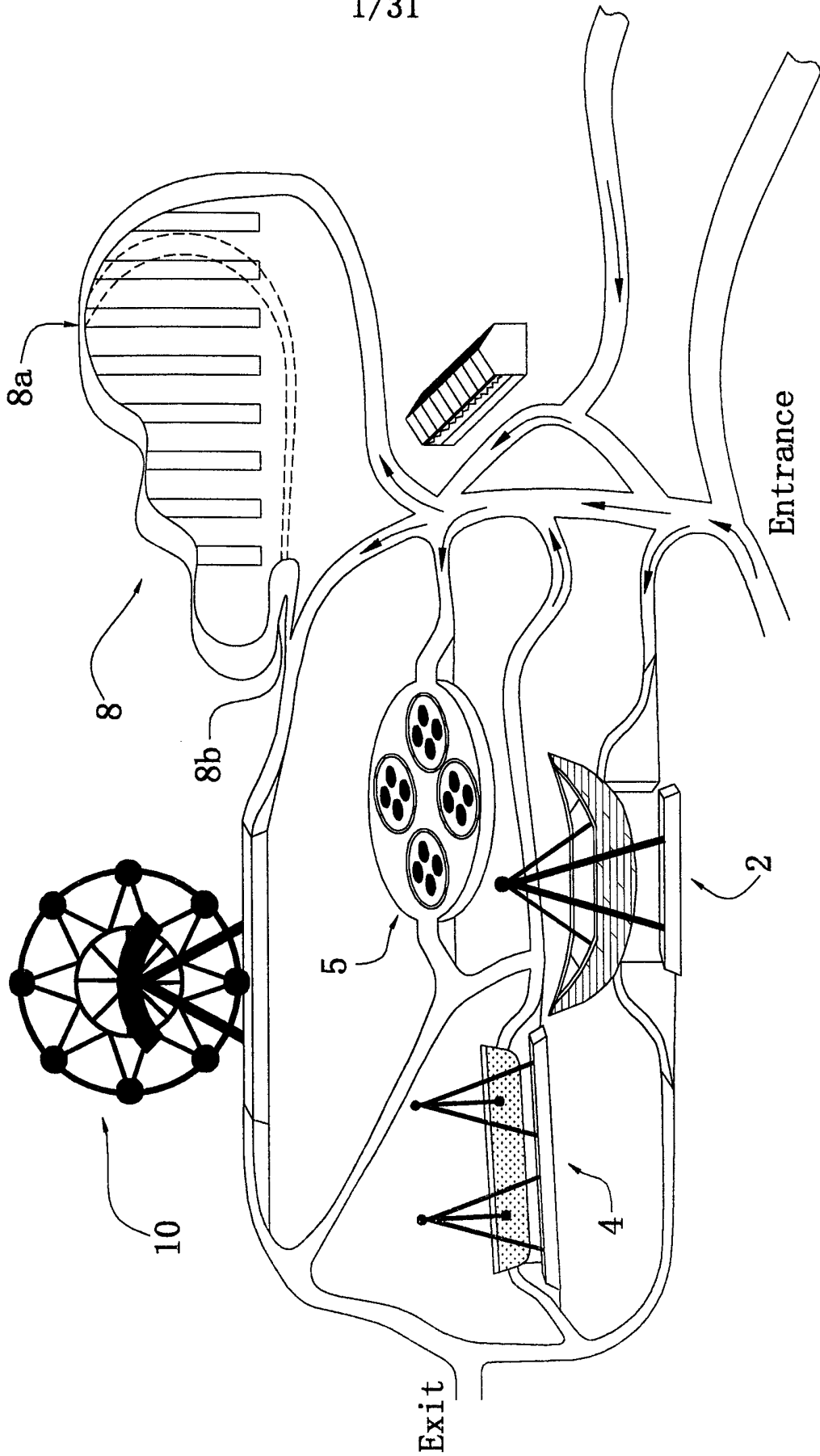

Fig. 1

2/31

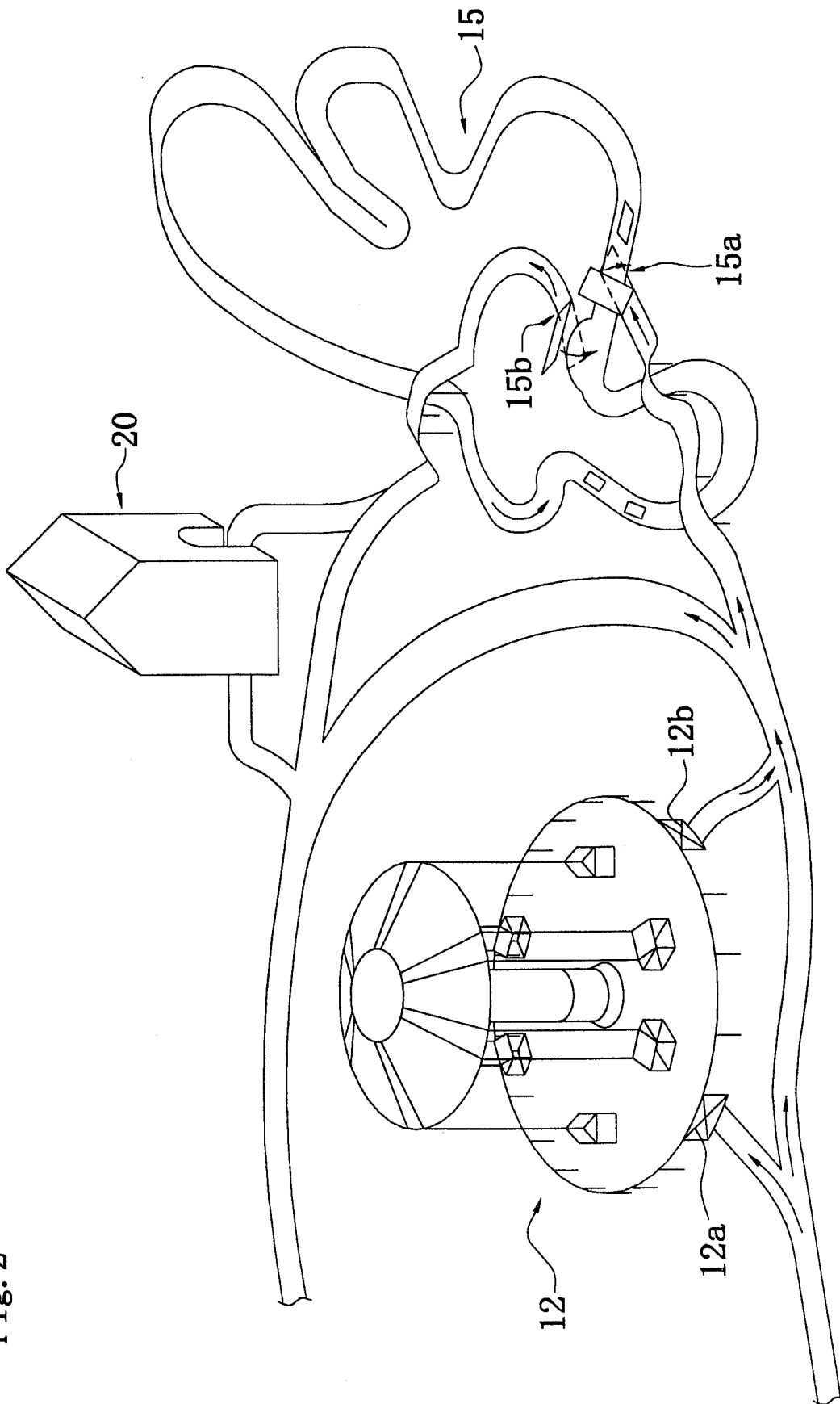

Fig. 2

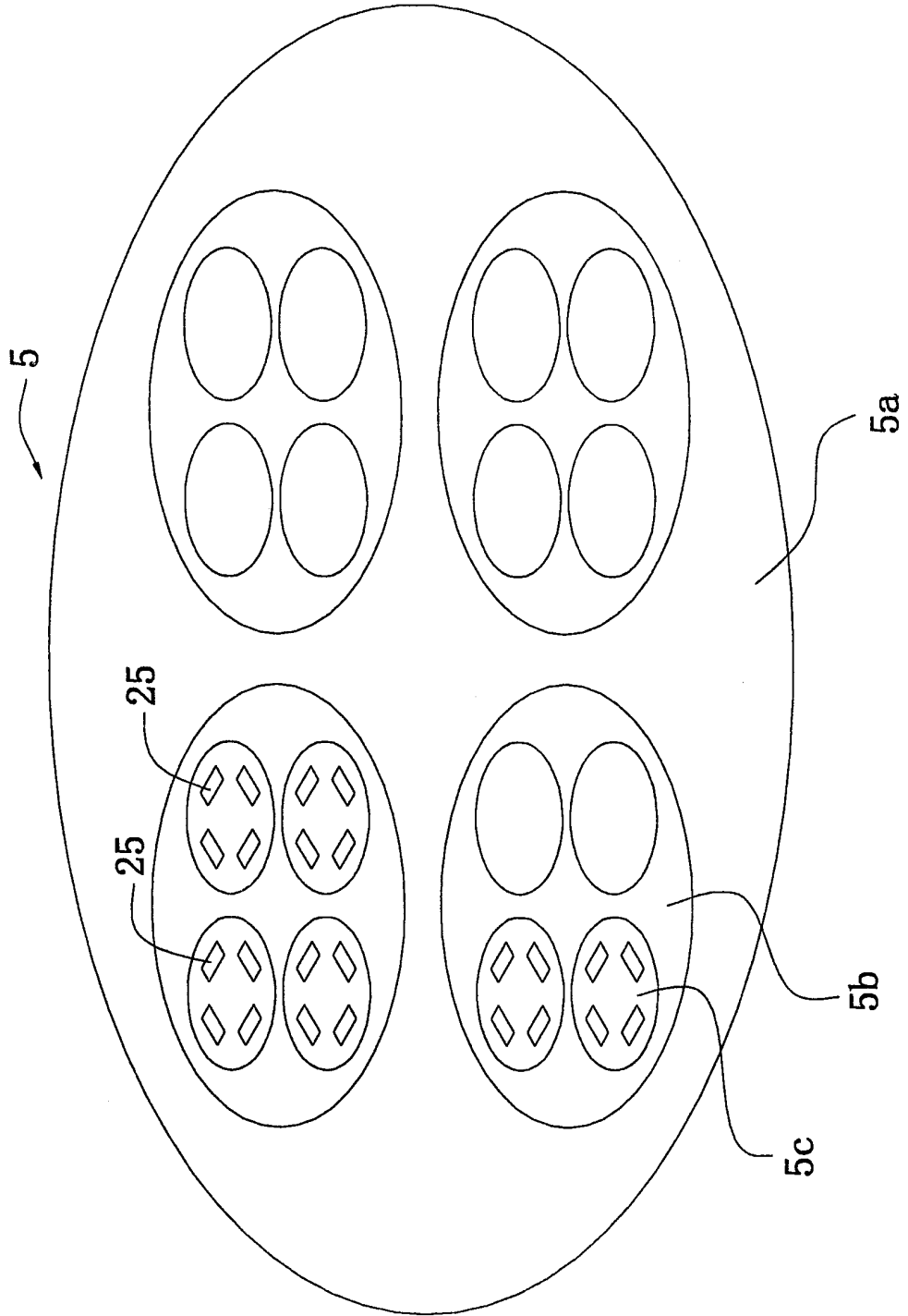

Fig. 3

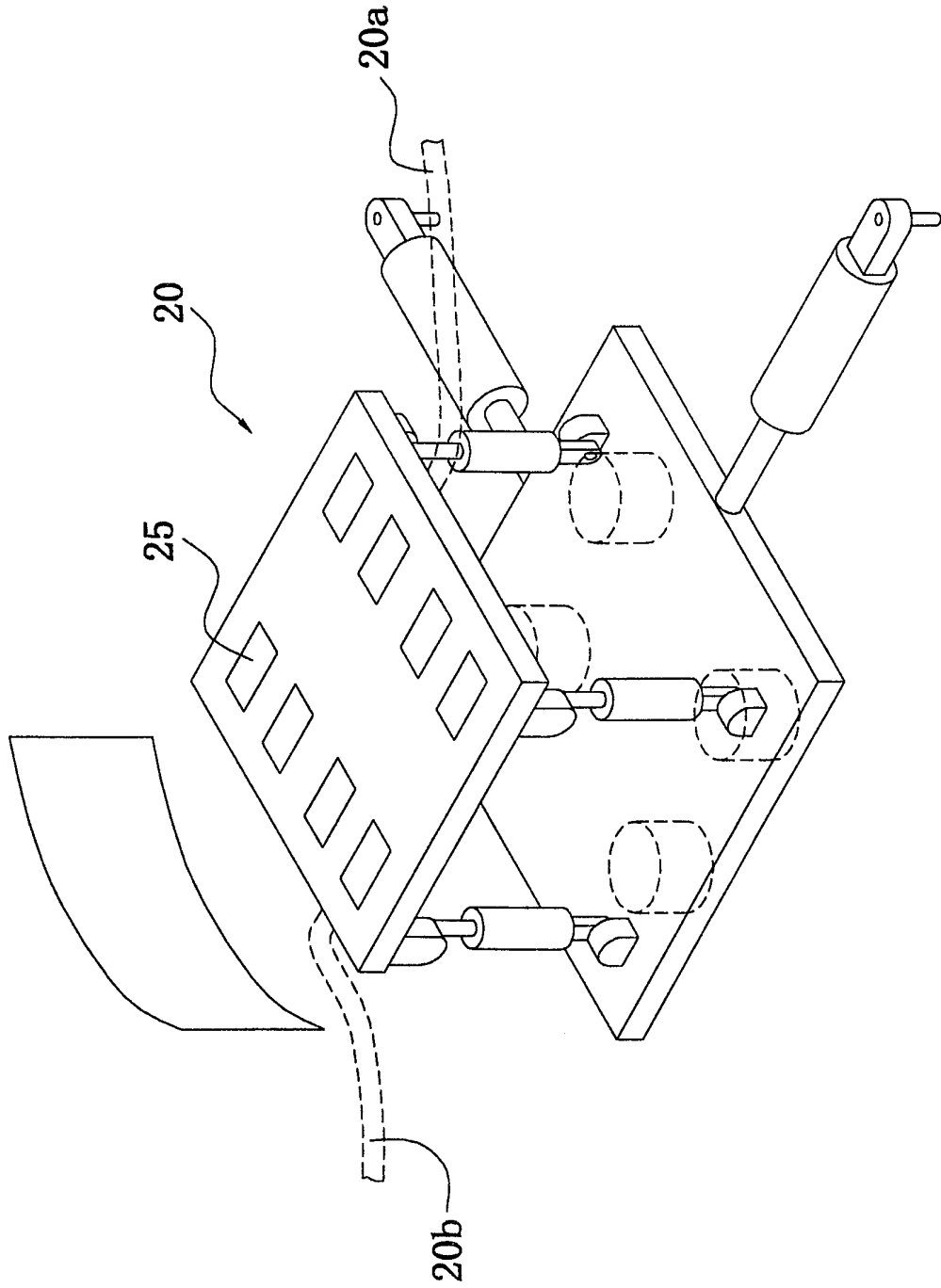

Fig. 4

5/31

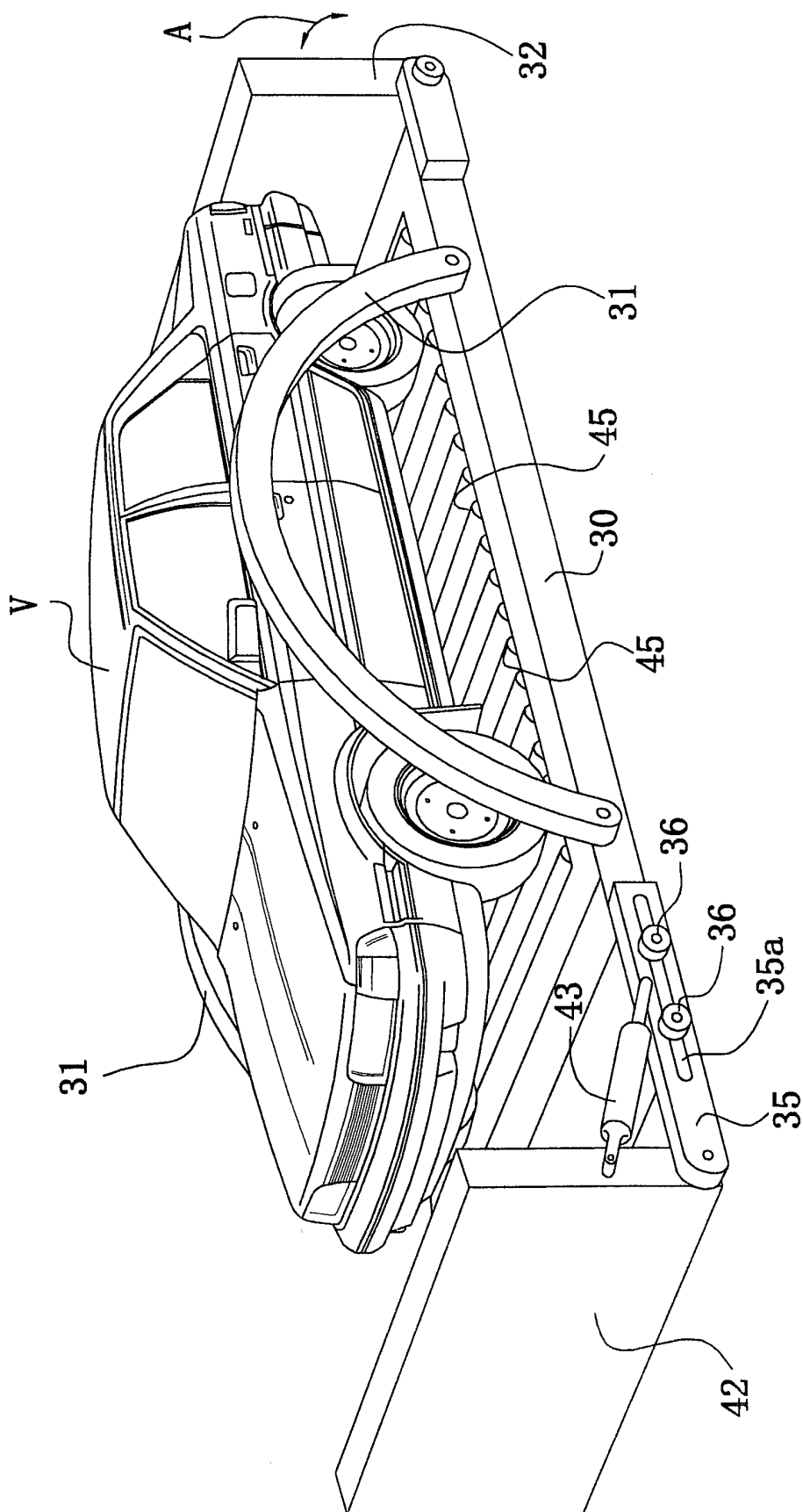
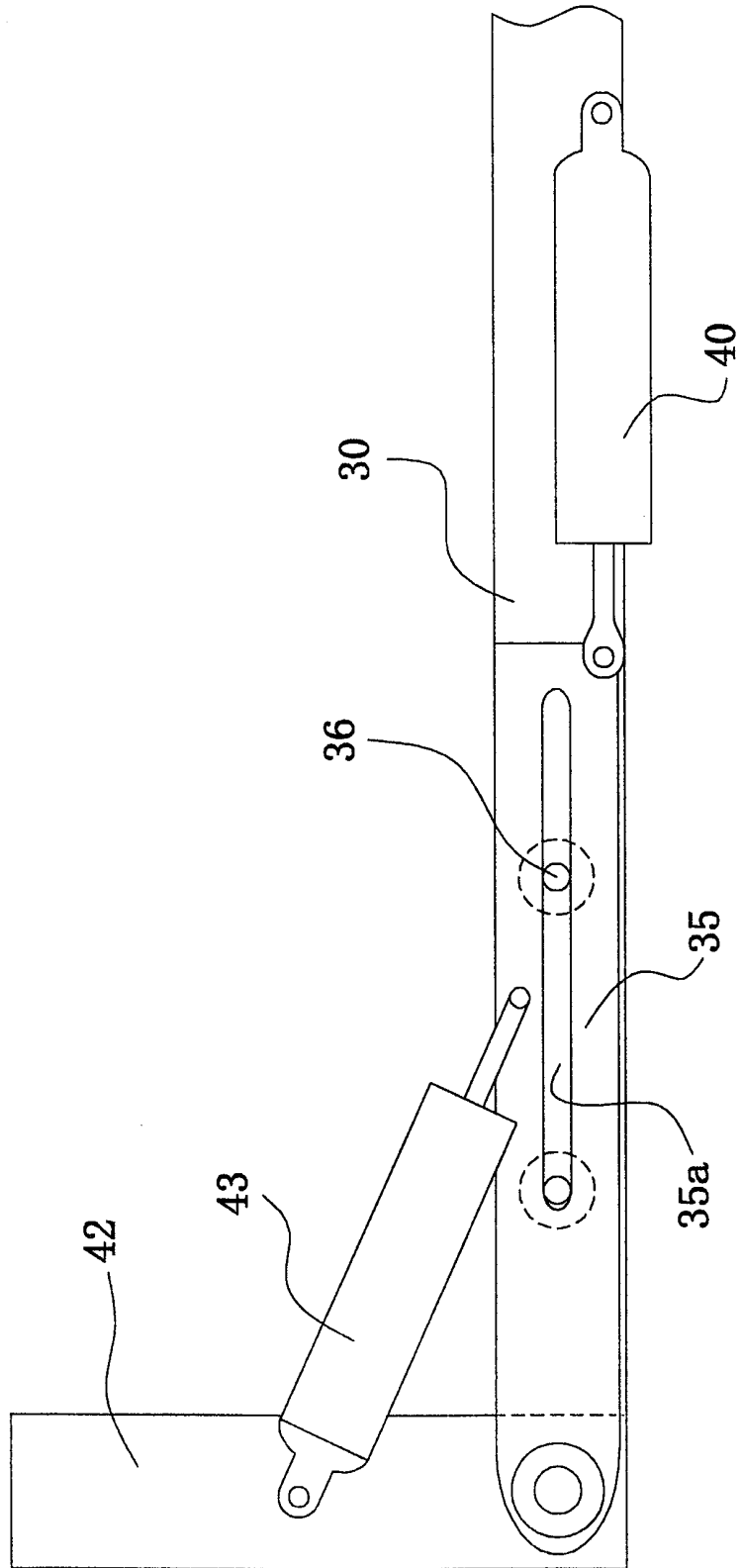

Fig. 5

Fig. 6



7/31

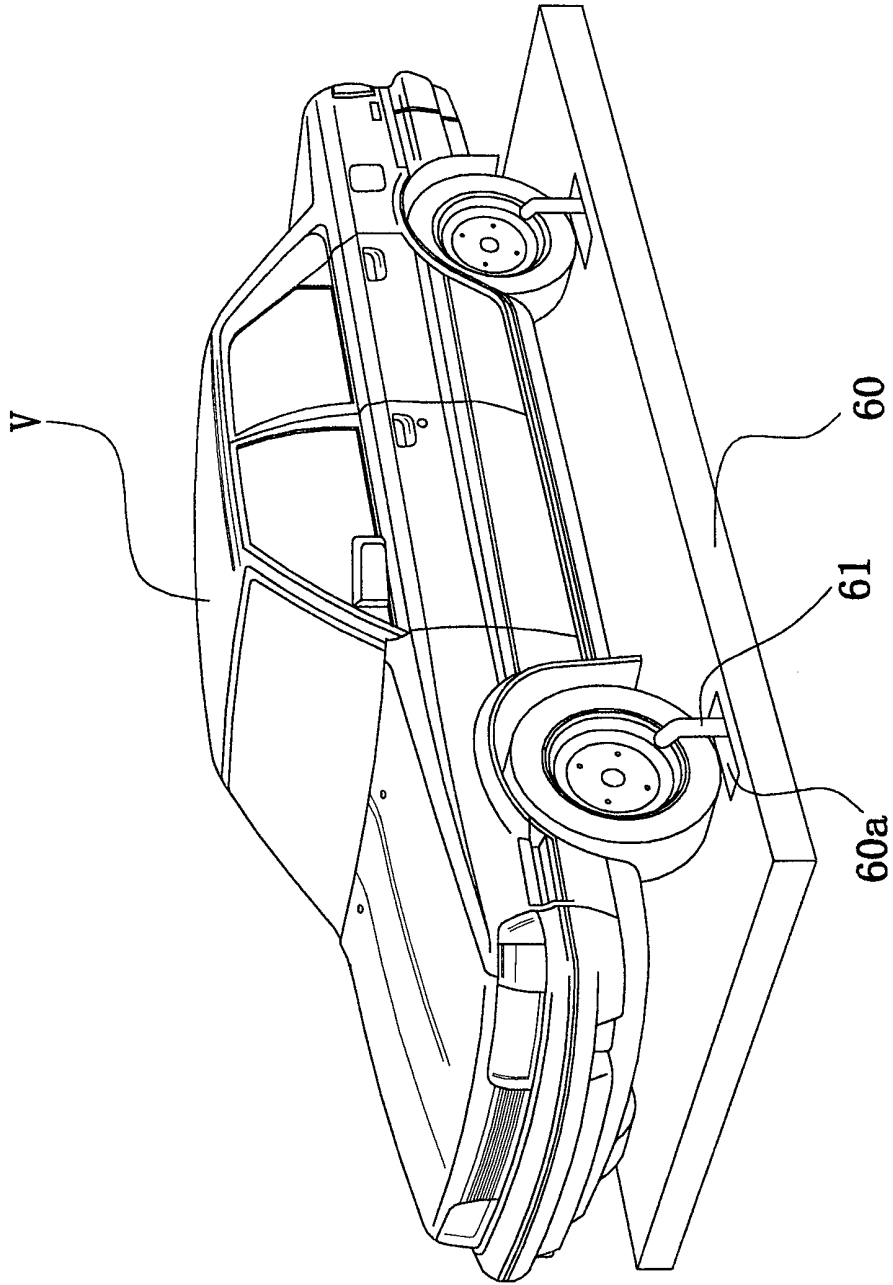
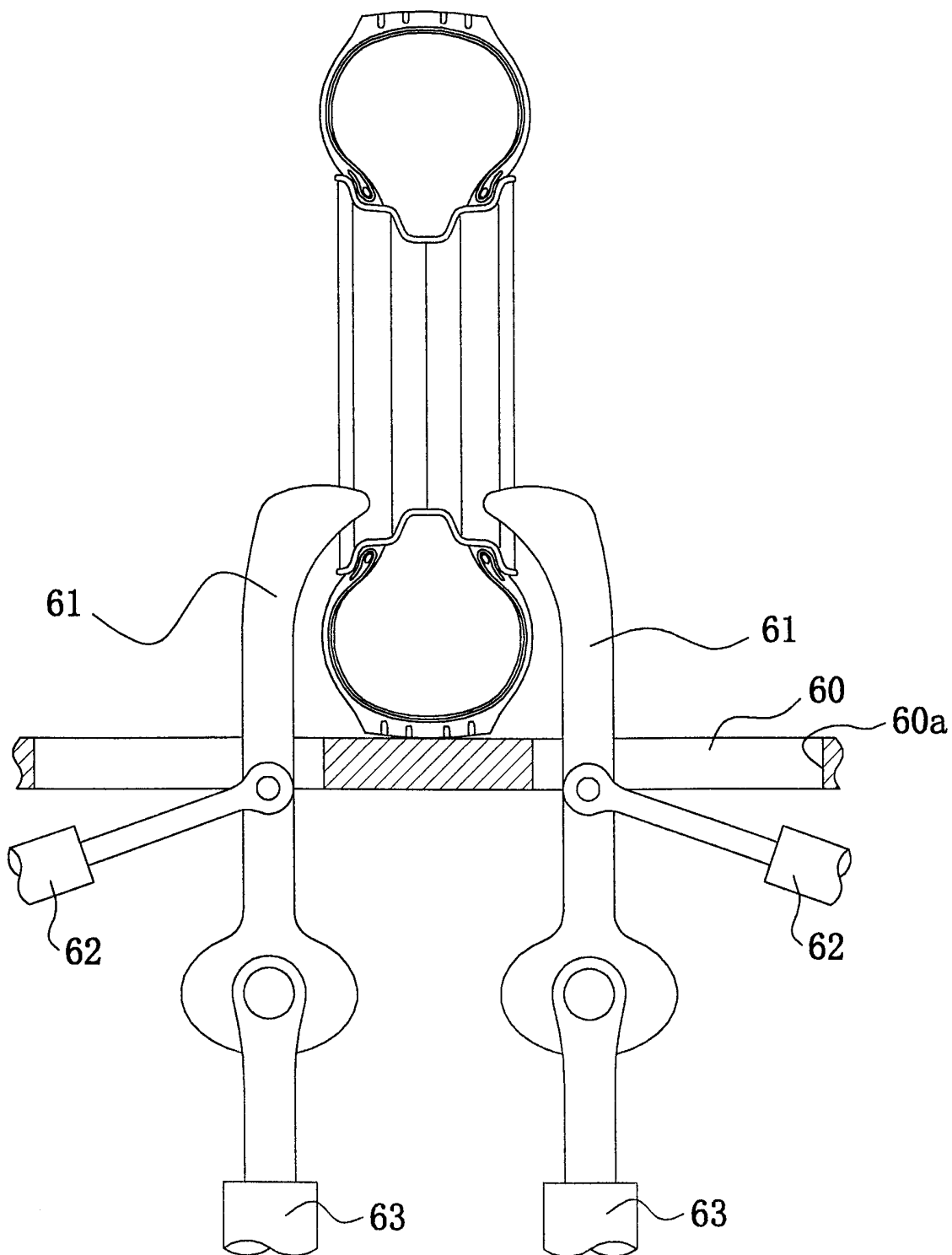

Fig. 7

Fig. 8

8/31



9/31

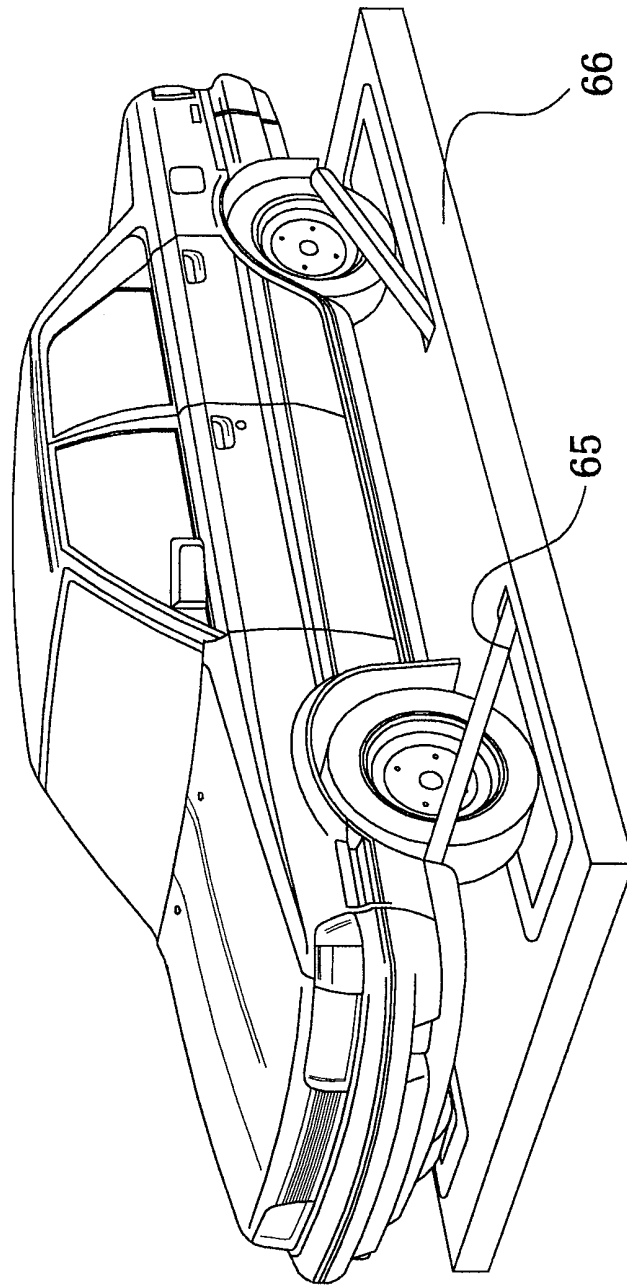
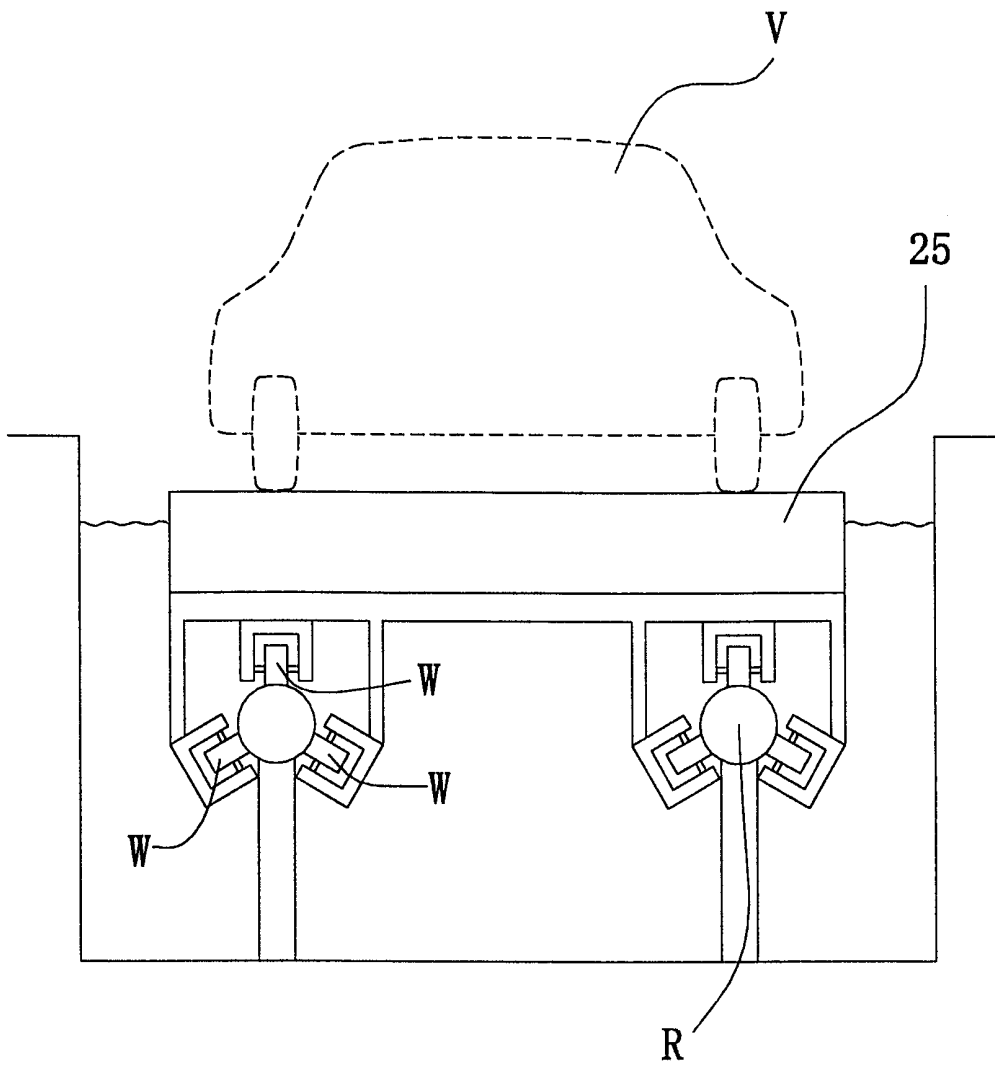

Fig. 9

10/31

Fig. 10



11/31

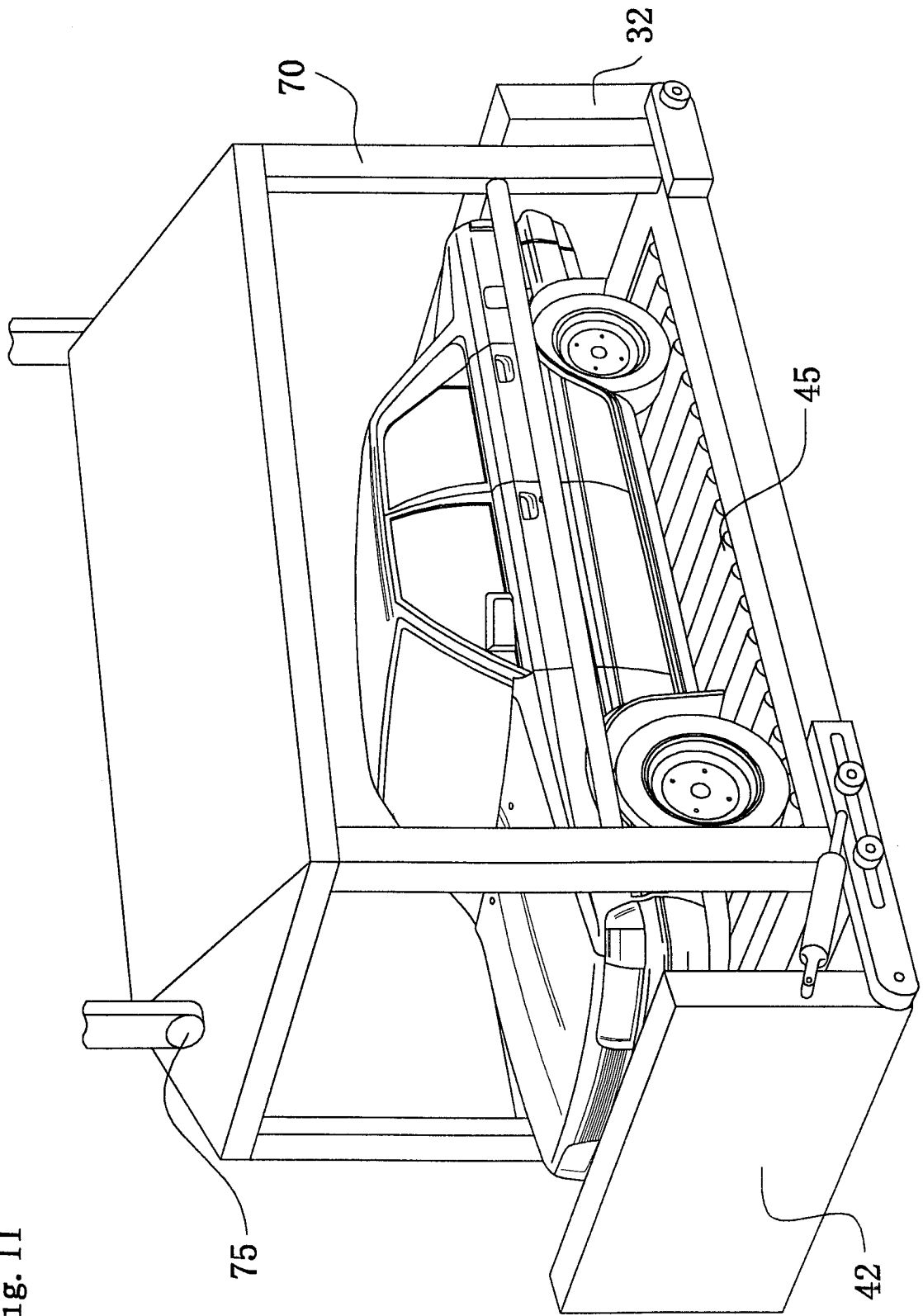
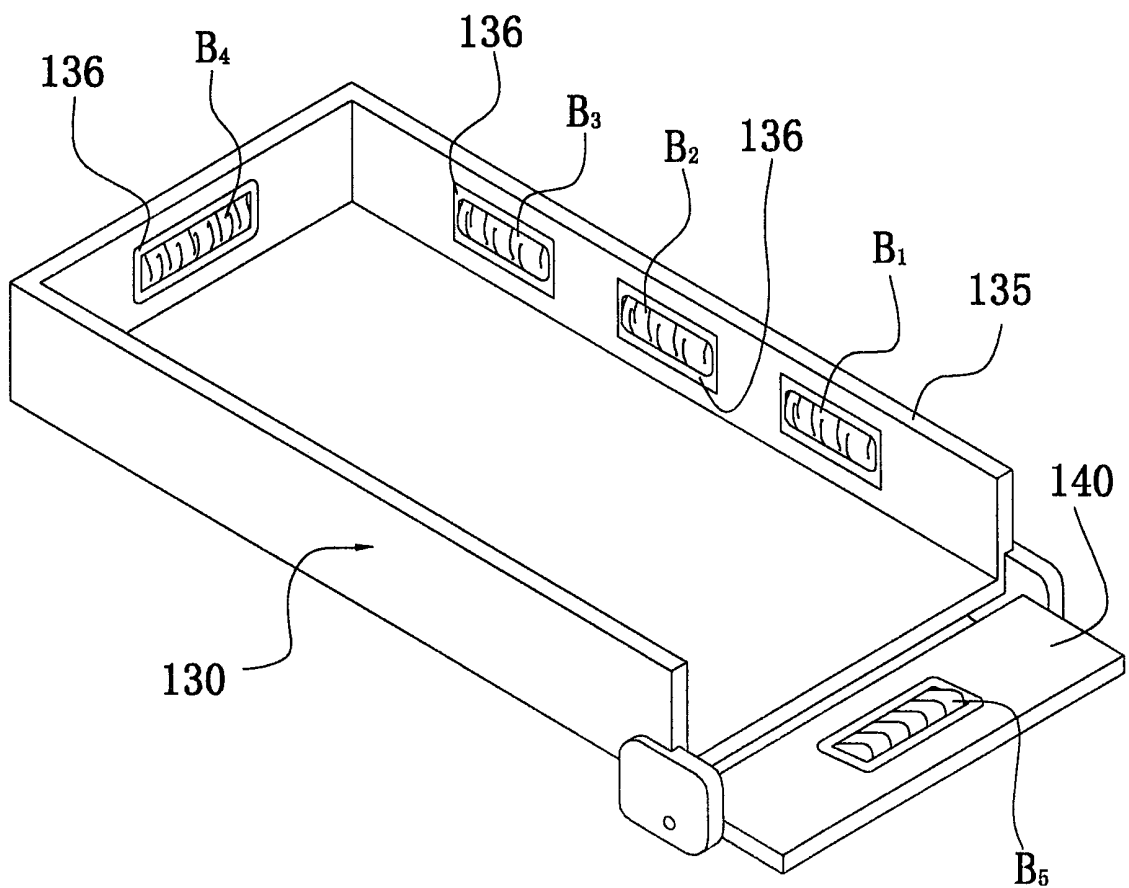

Fig. 11

Fig. 12

12/31



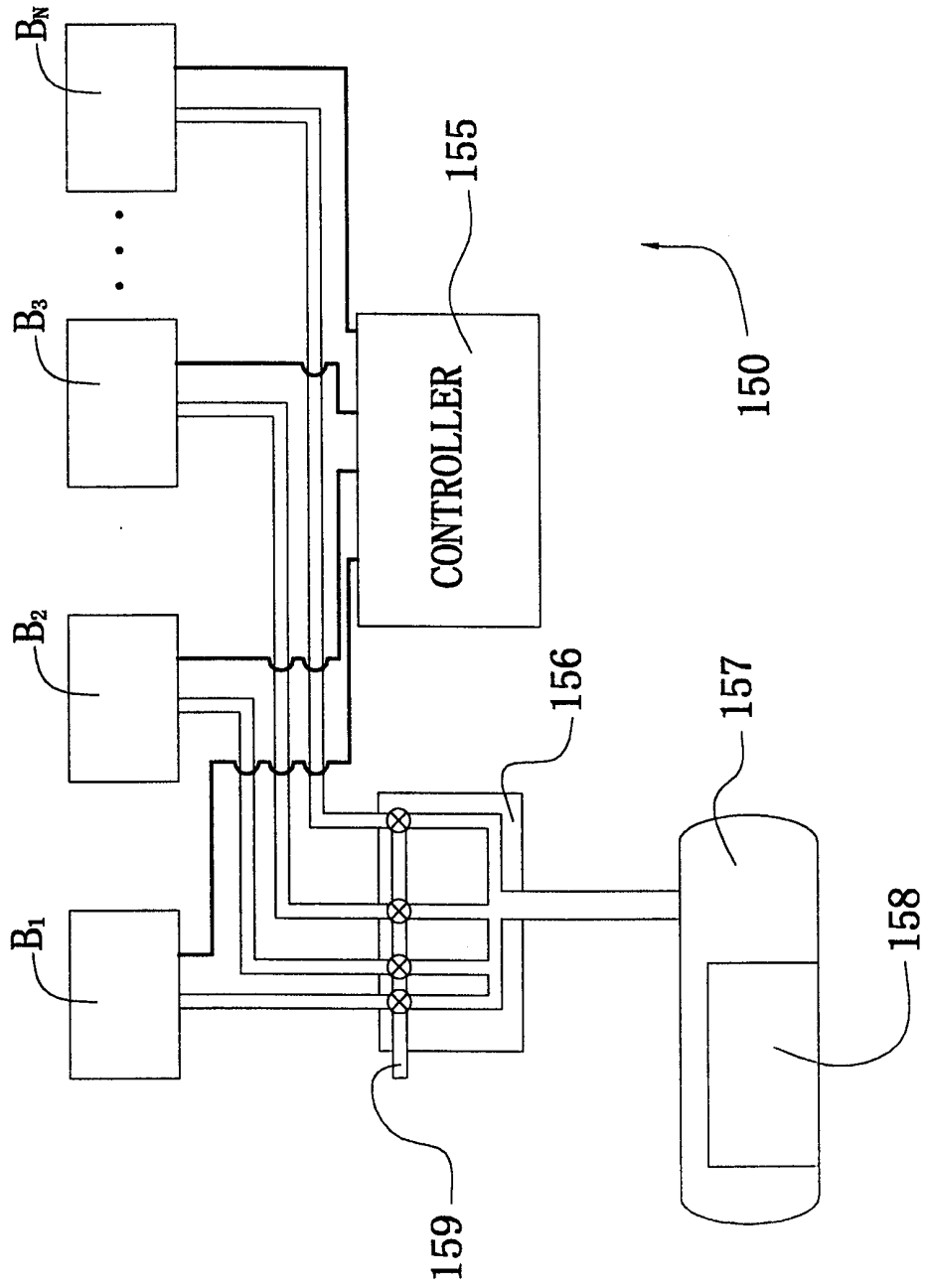

Fig. 13

Fig. 14

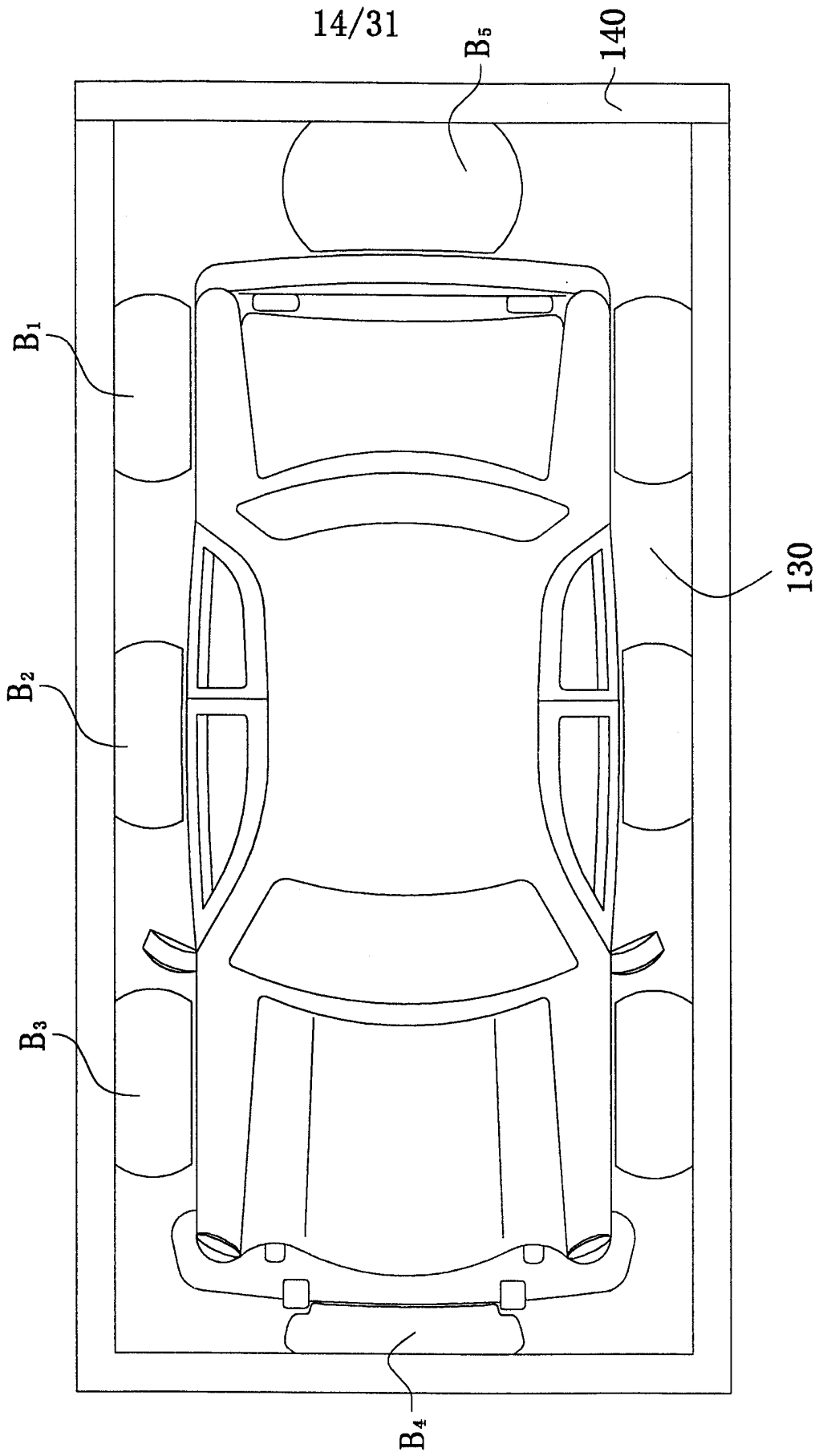
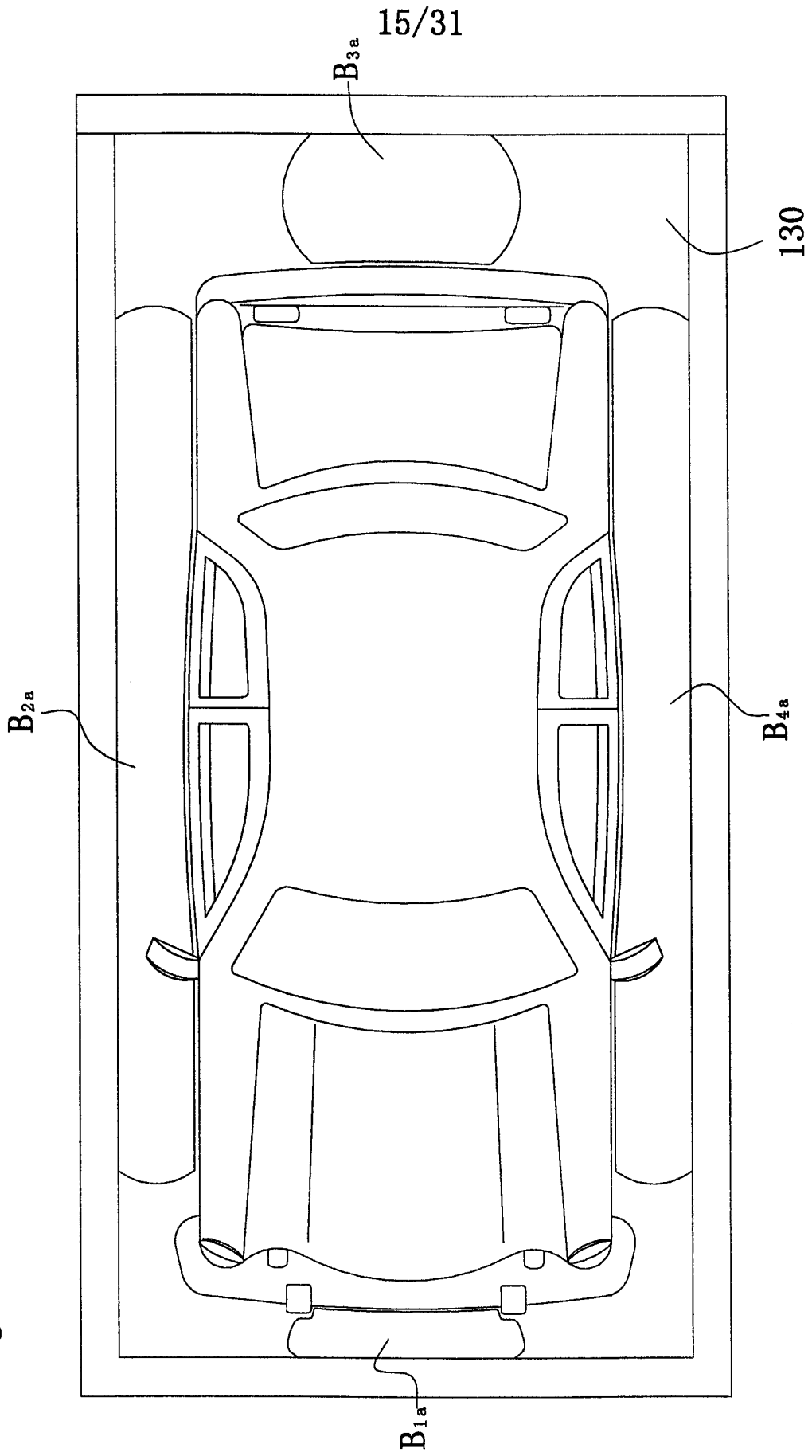

Fig. 15



16/31

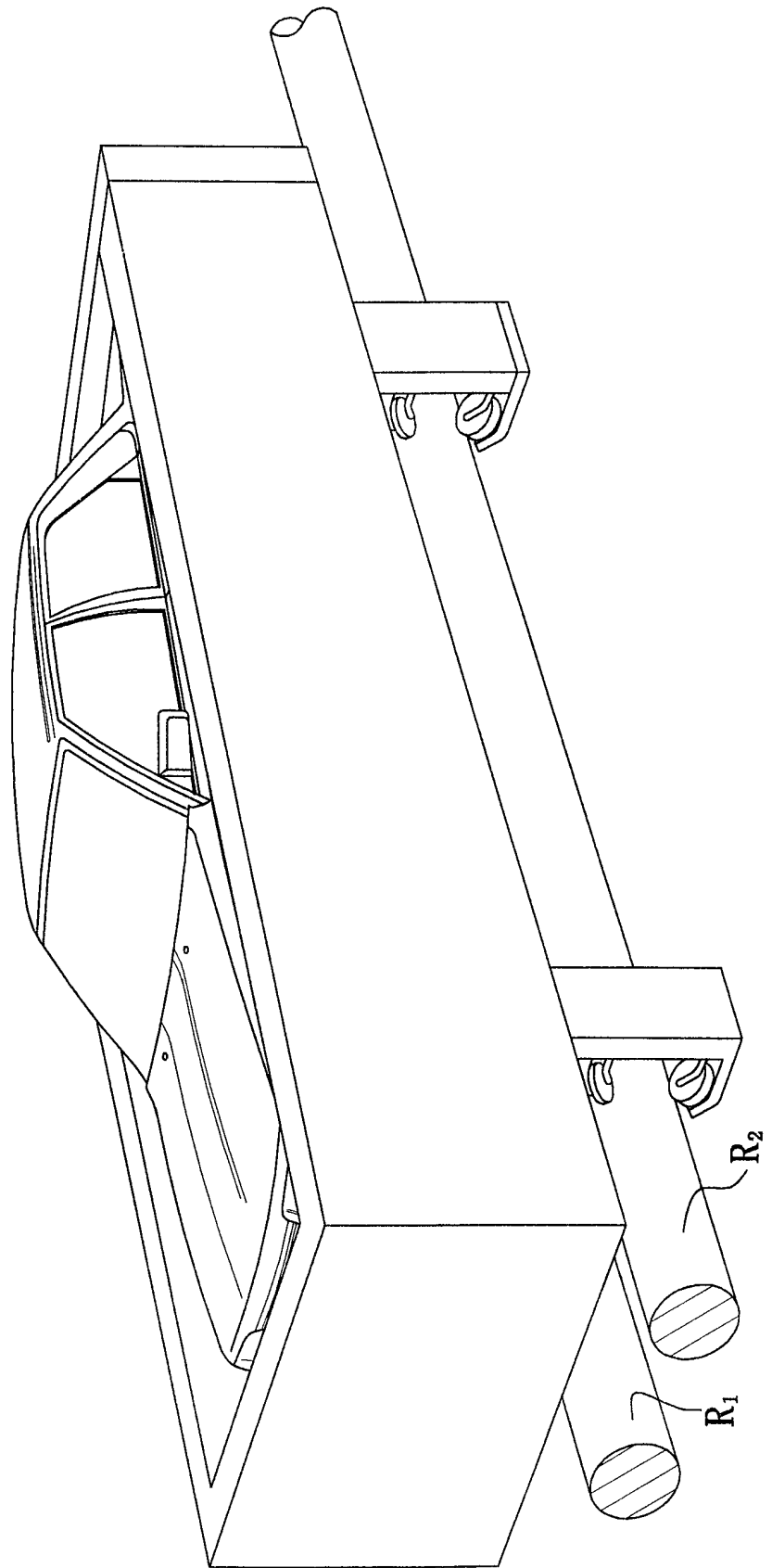

Fig. 16

17/31

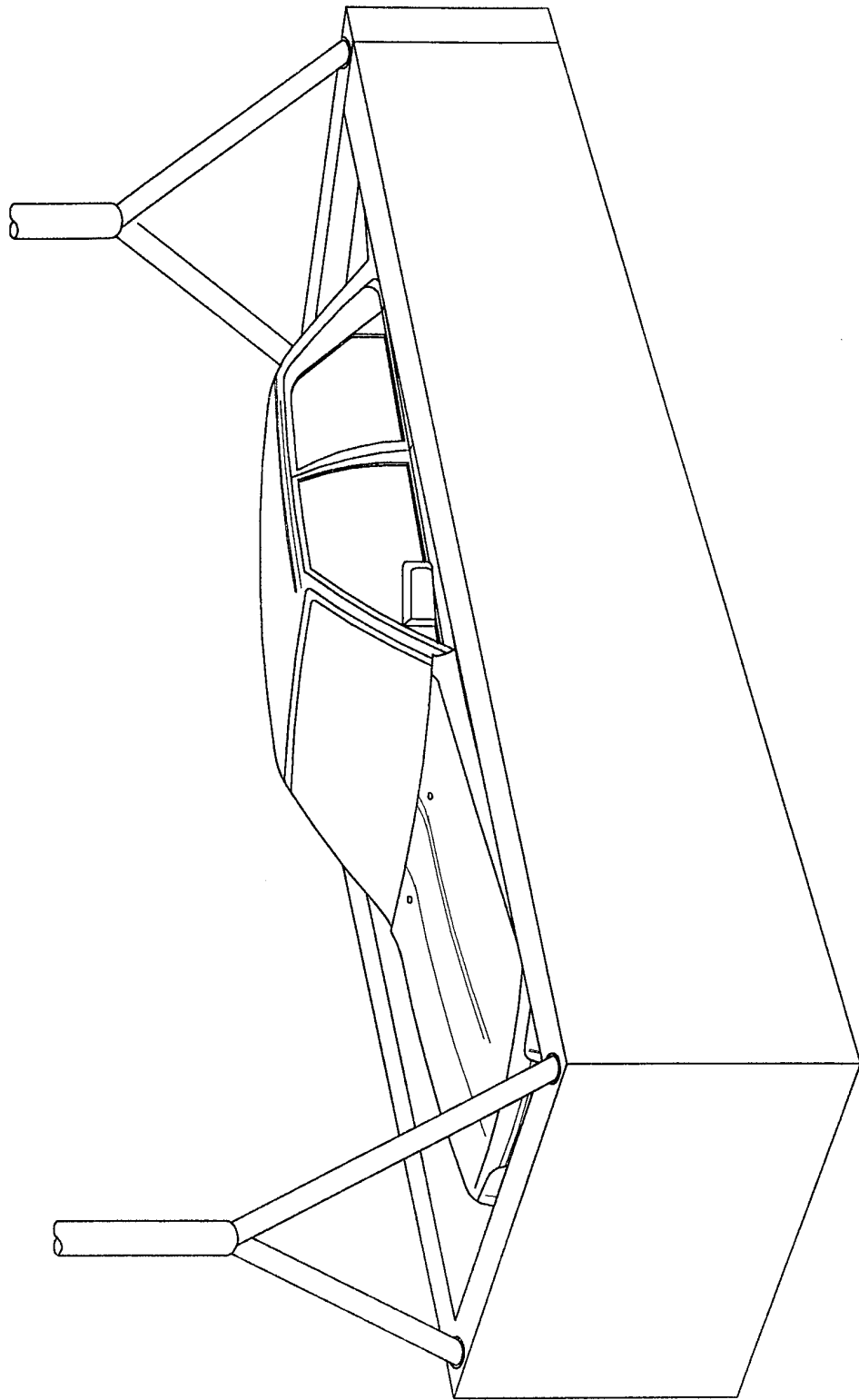

Fig. 17

18/31

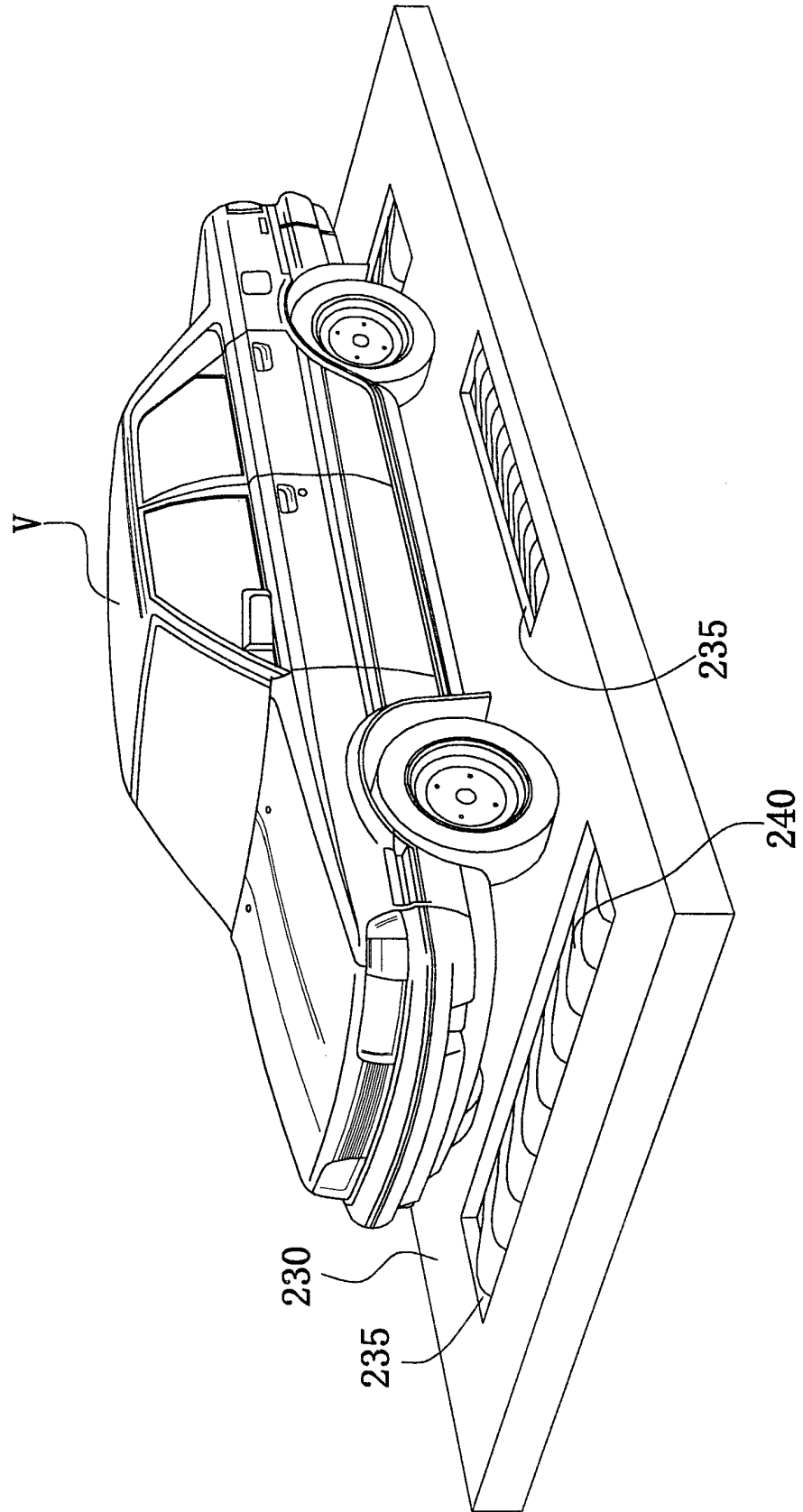

Fig. 18

19/31

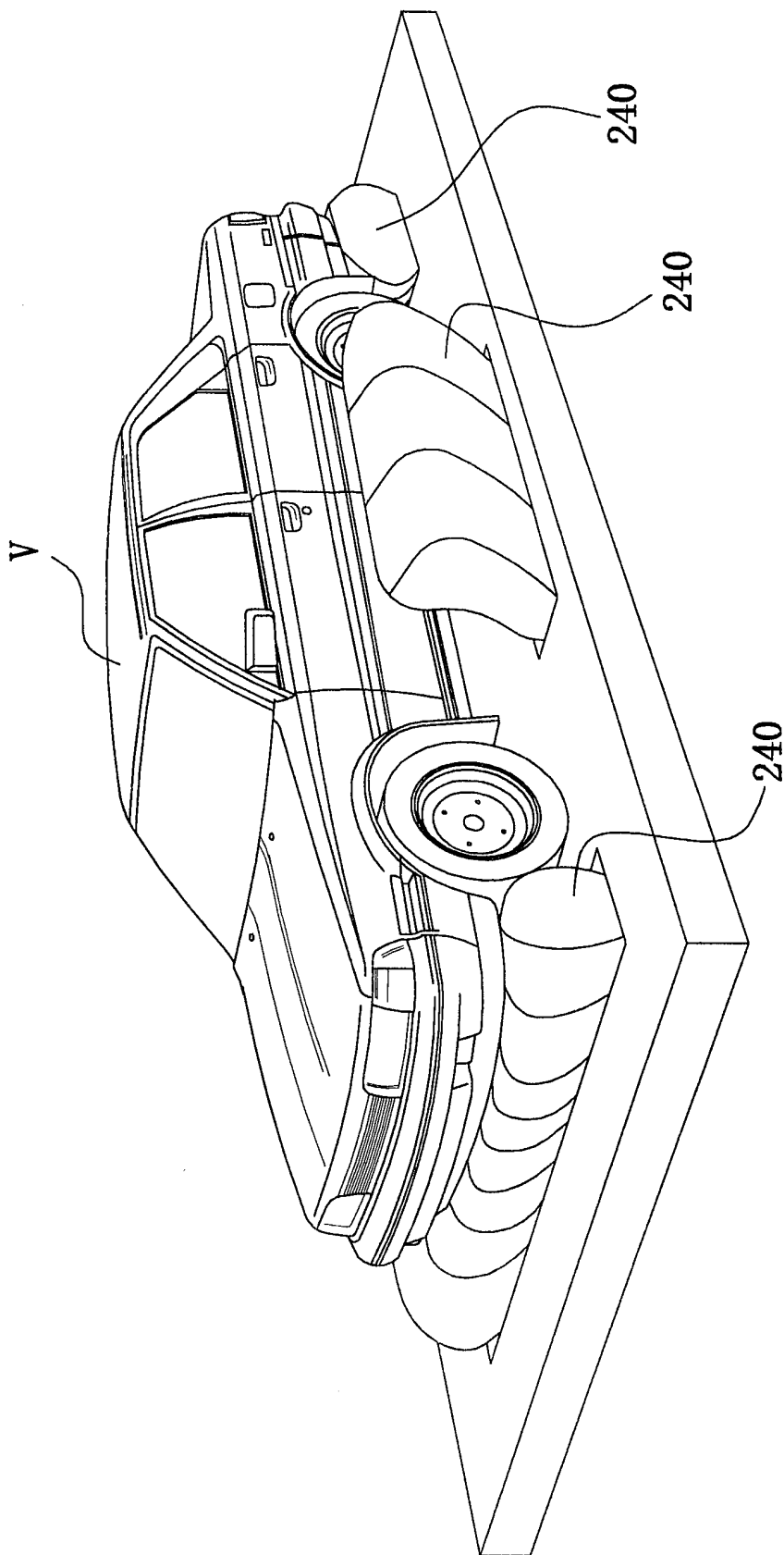

Fig. 19

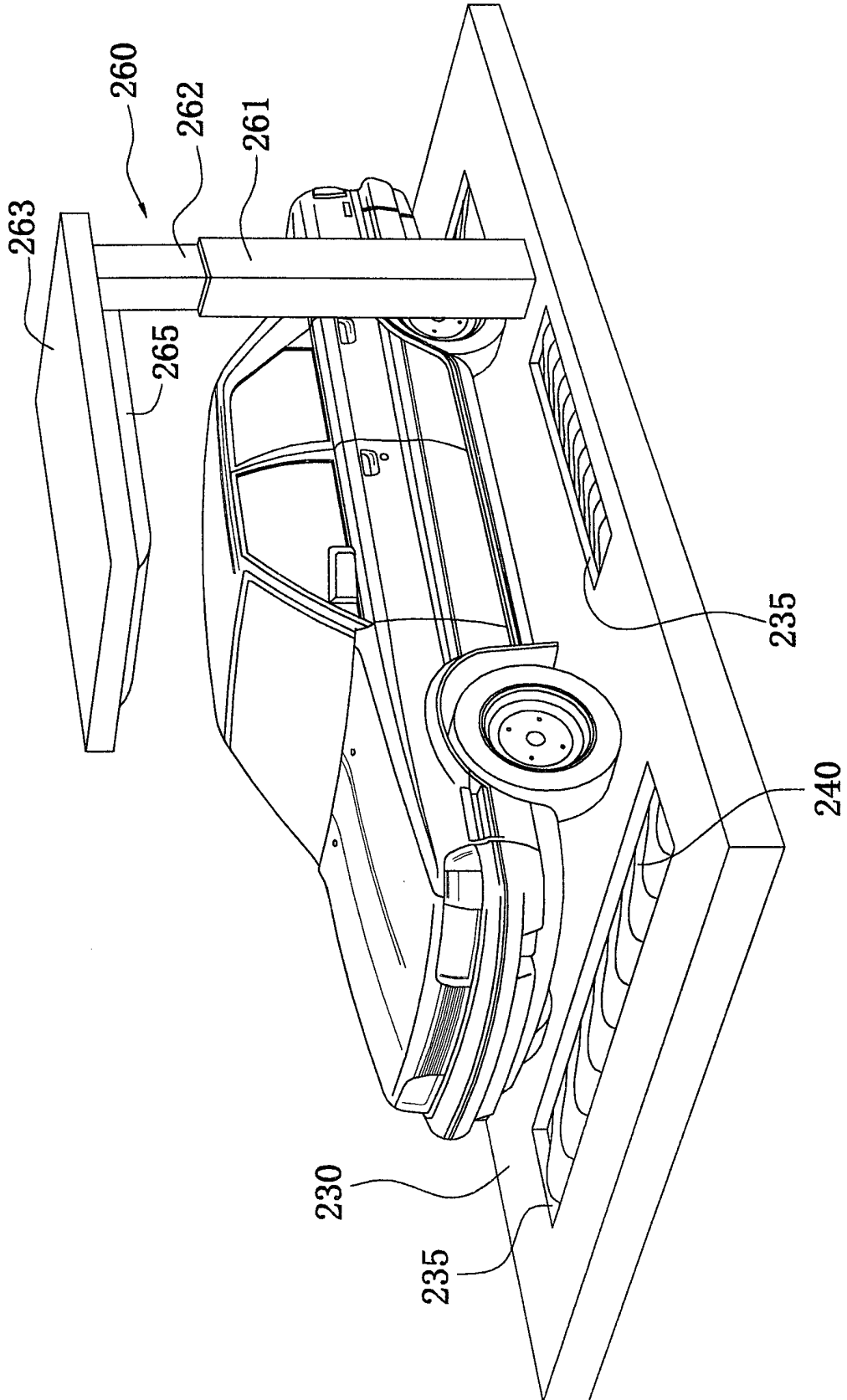

Fig. 20

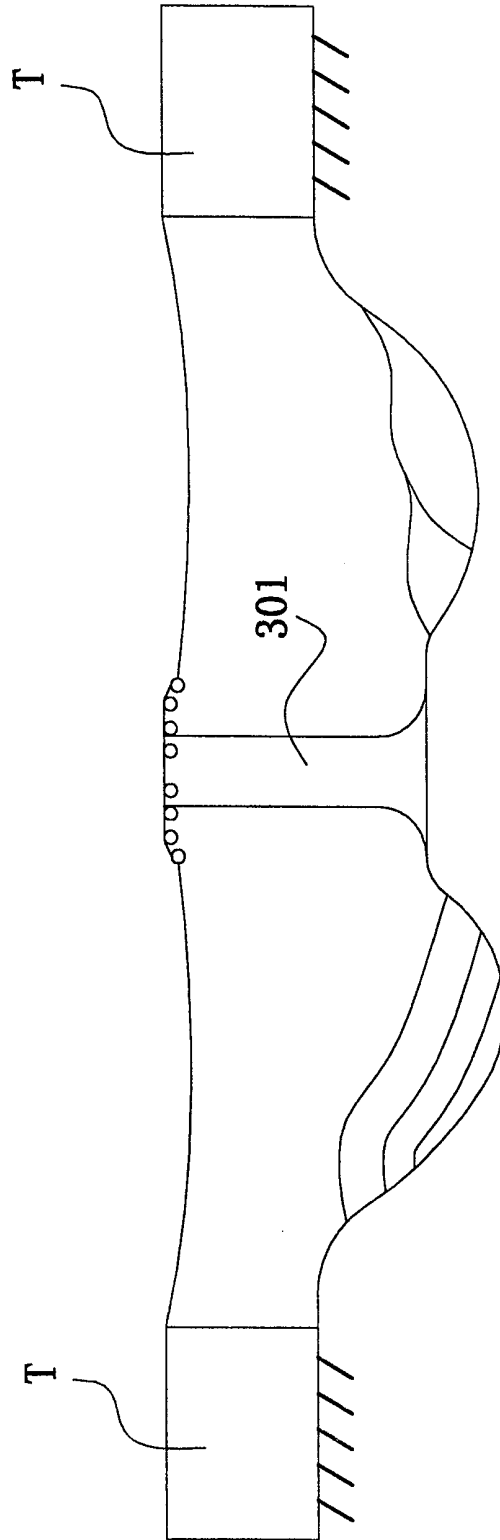

Fig. 21A

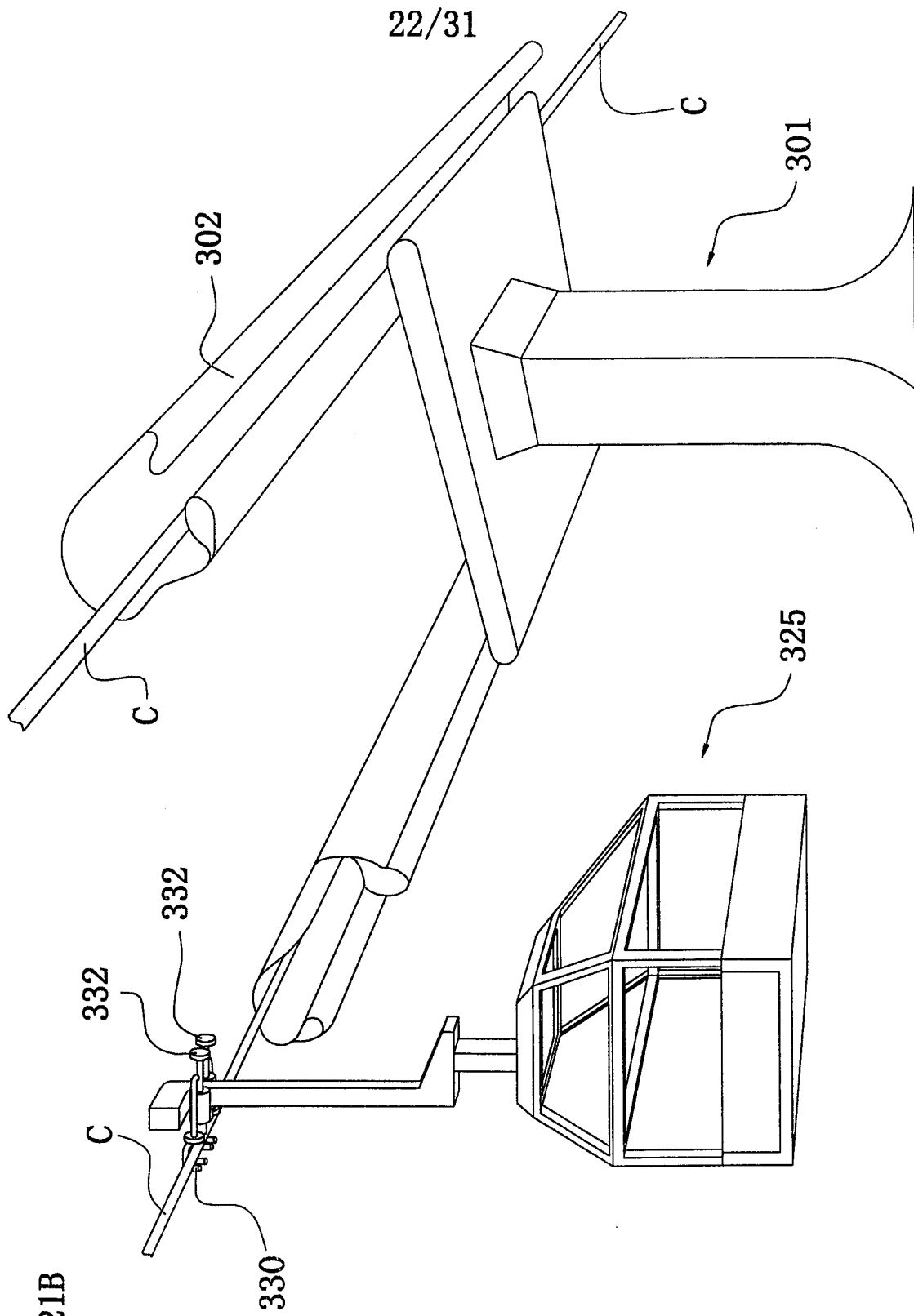
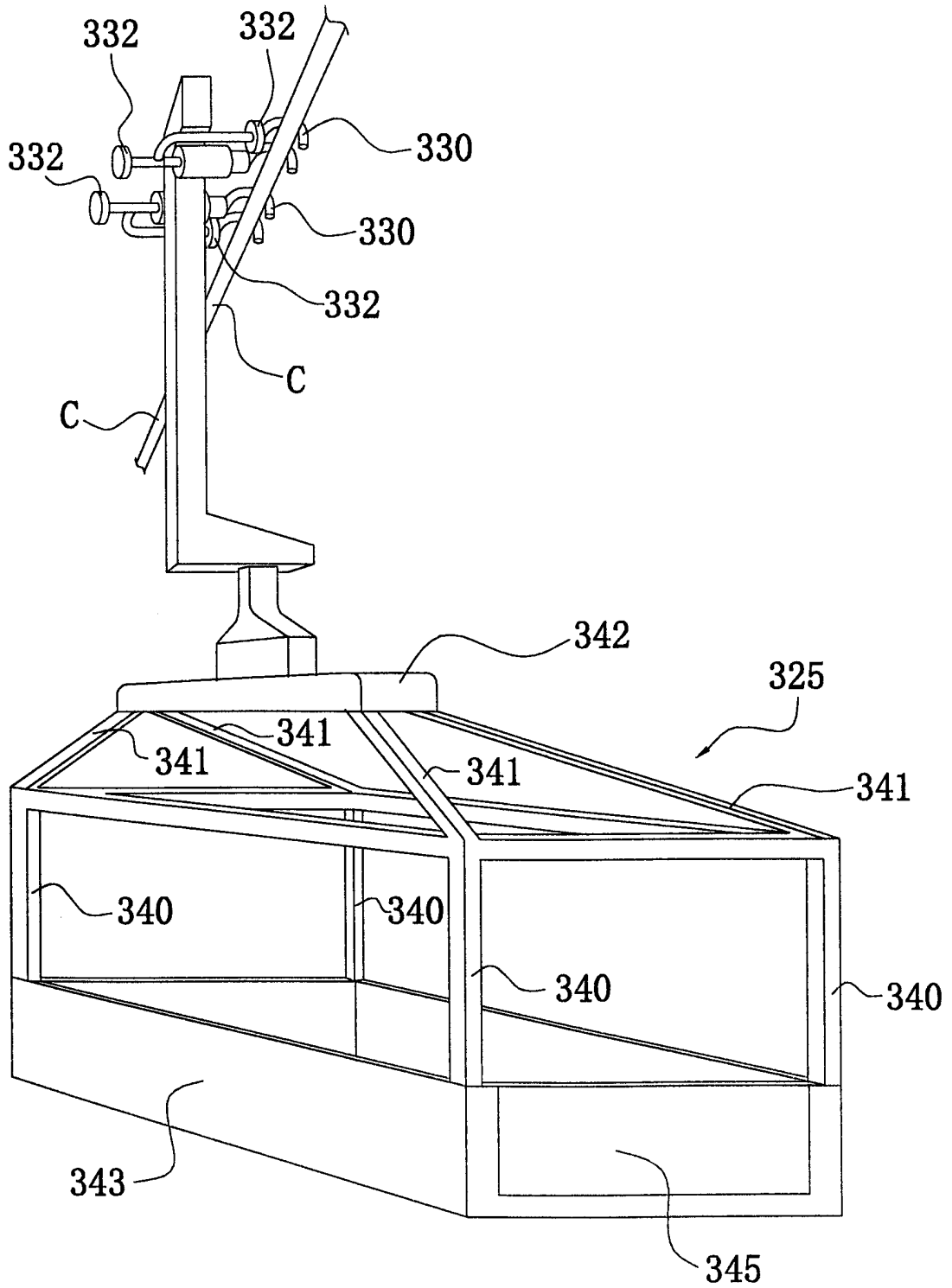

Fig. 21B

Fig. 22



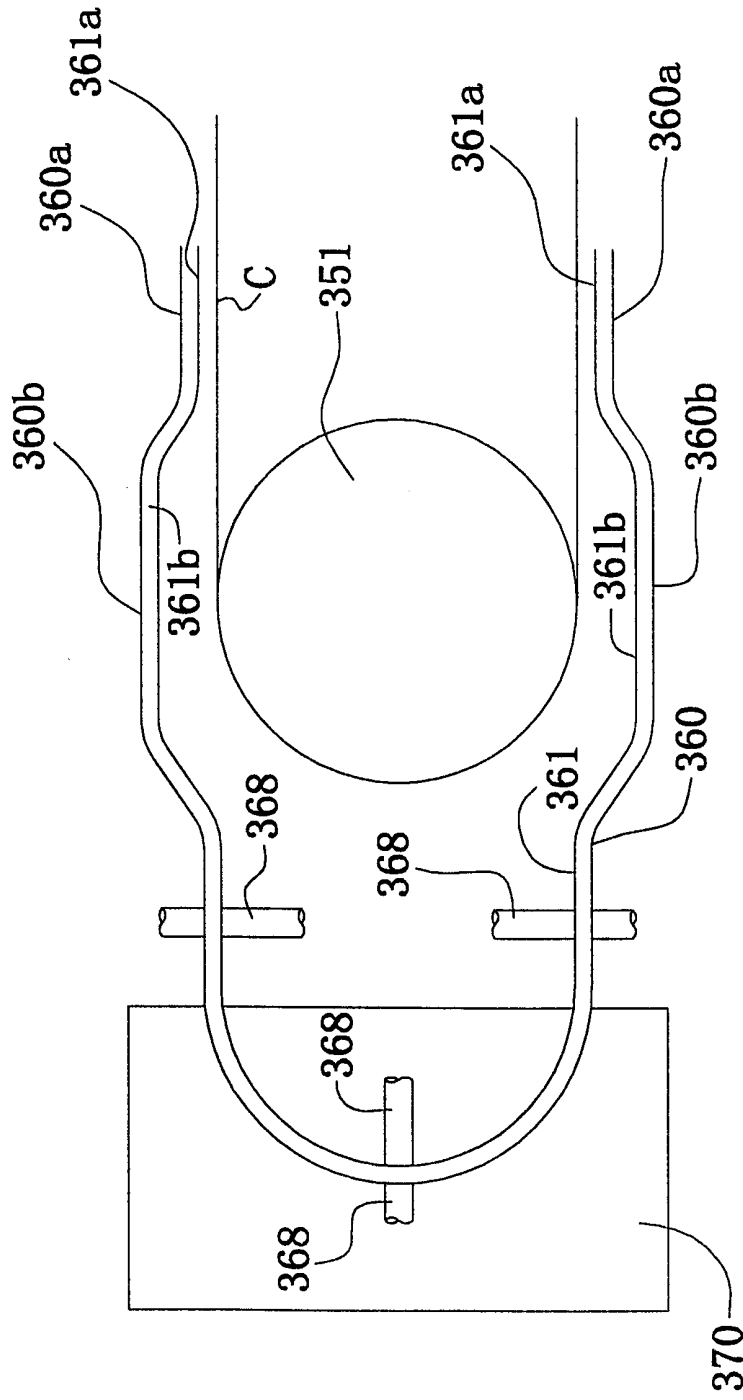

Fig. 24

Fig. 25

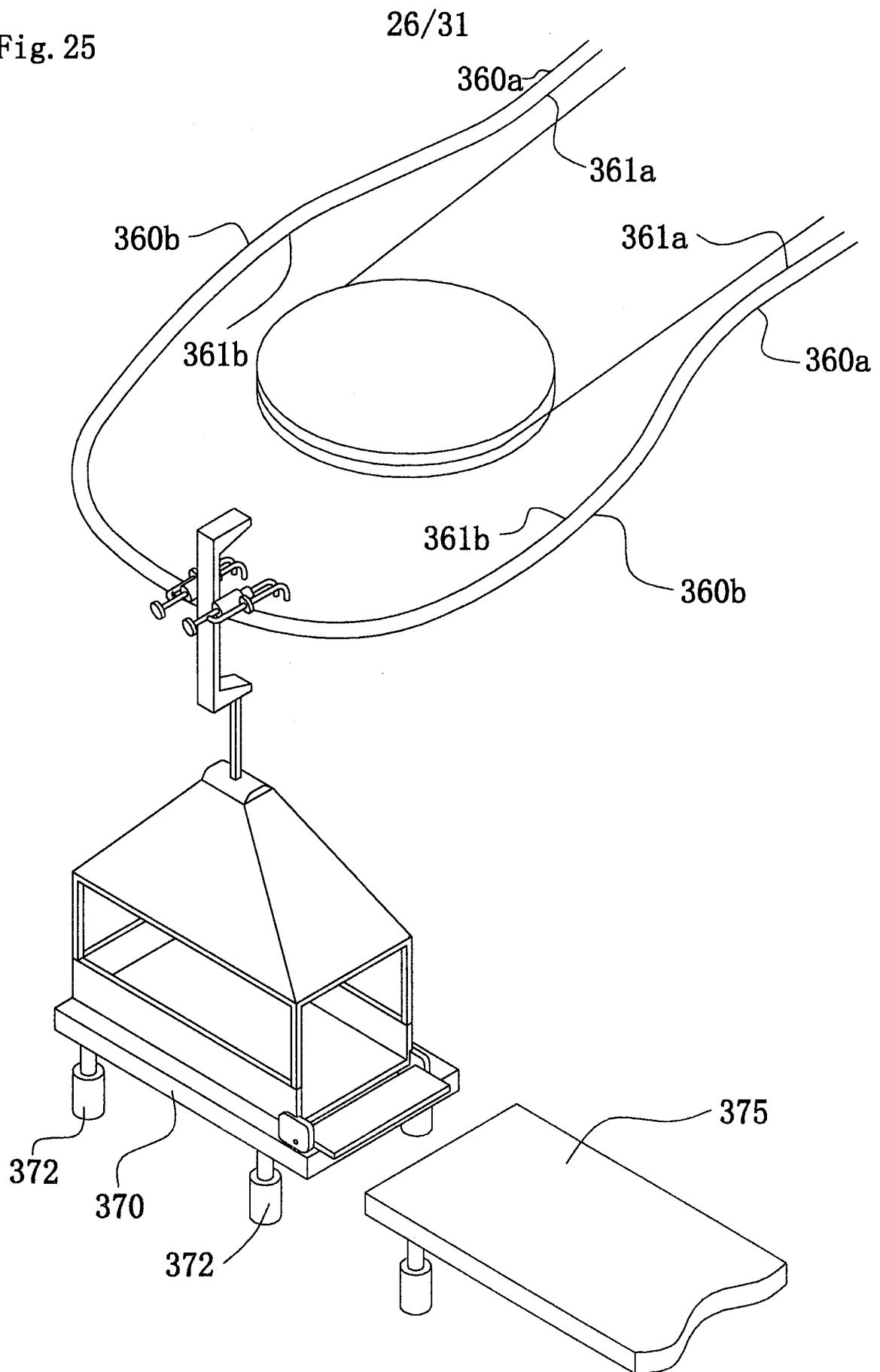

Fig. 26

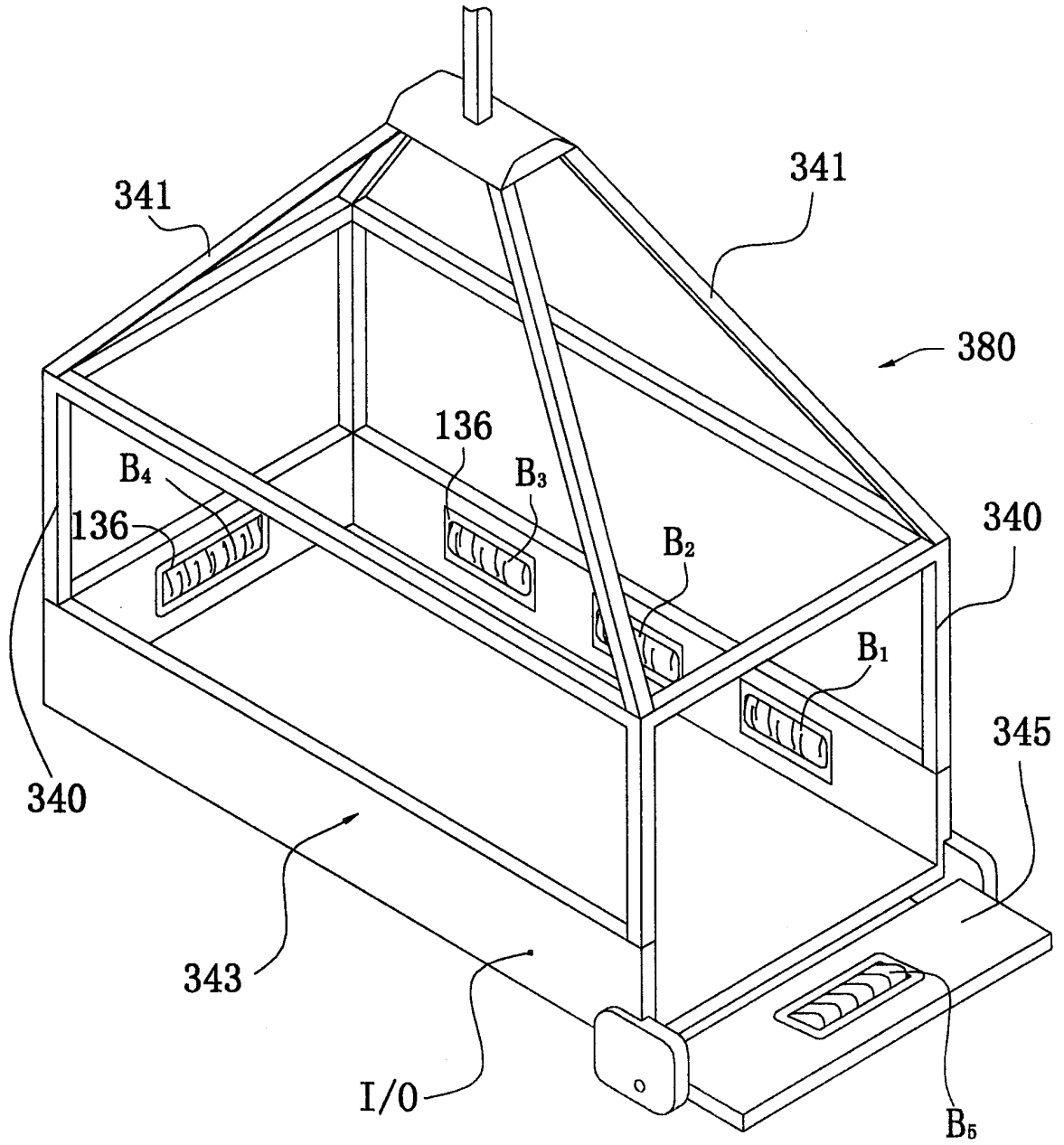

Fig. 27

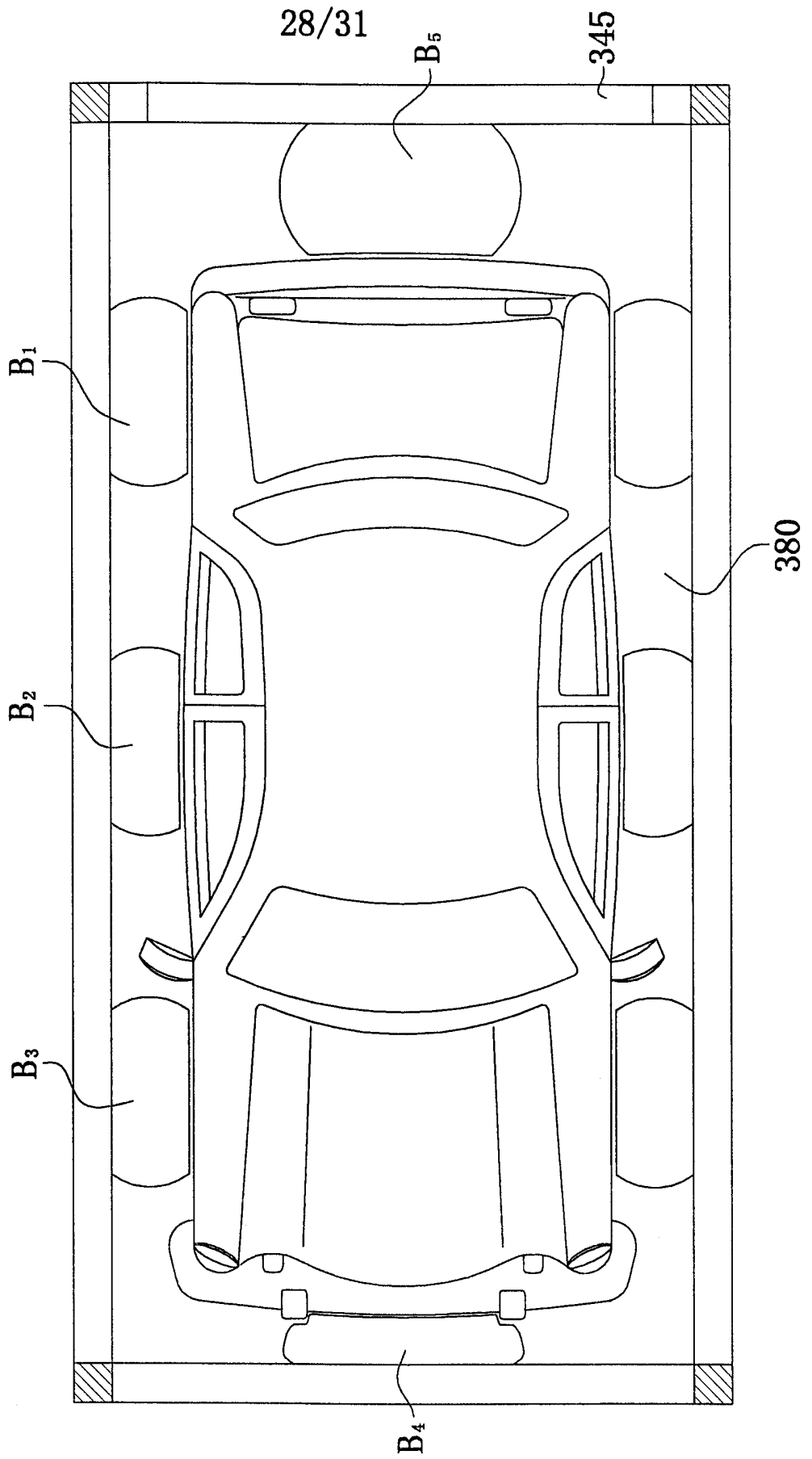
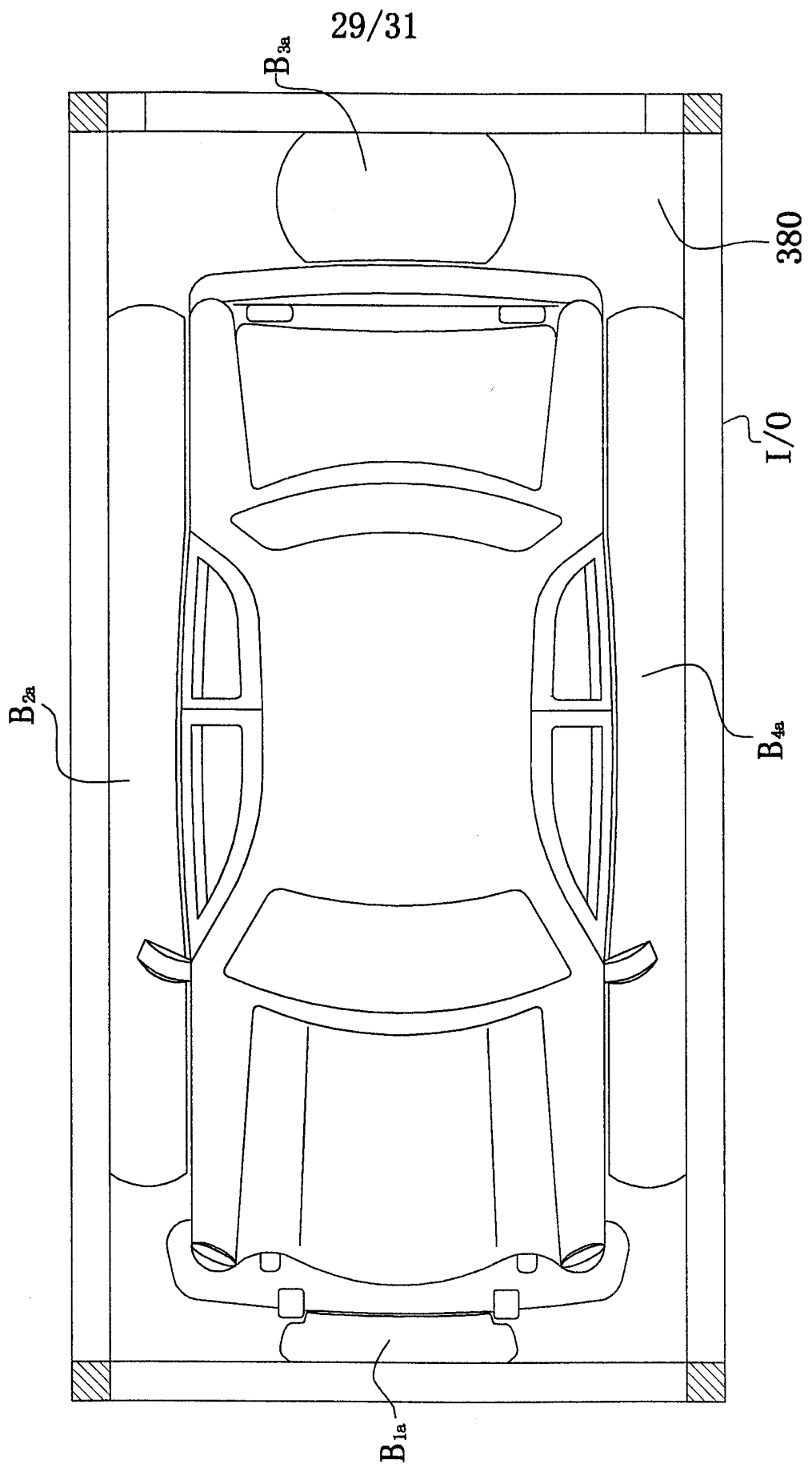

Fig. 28



30/31

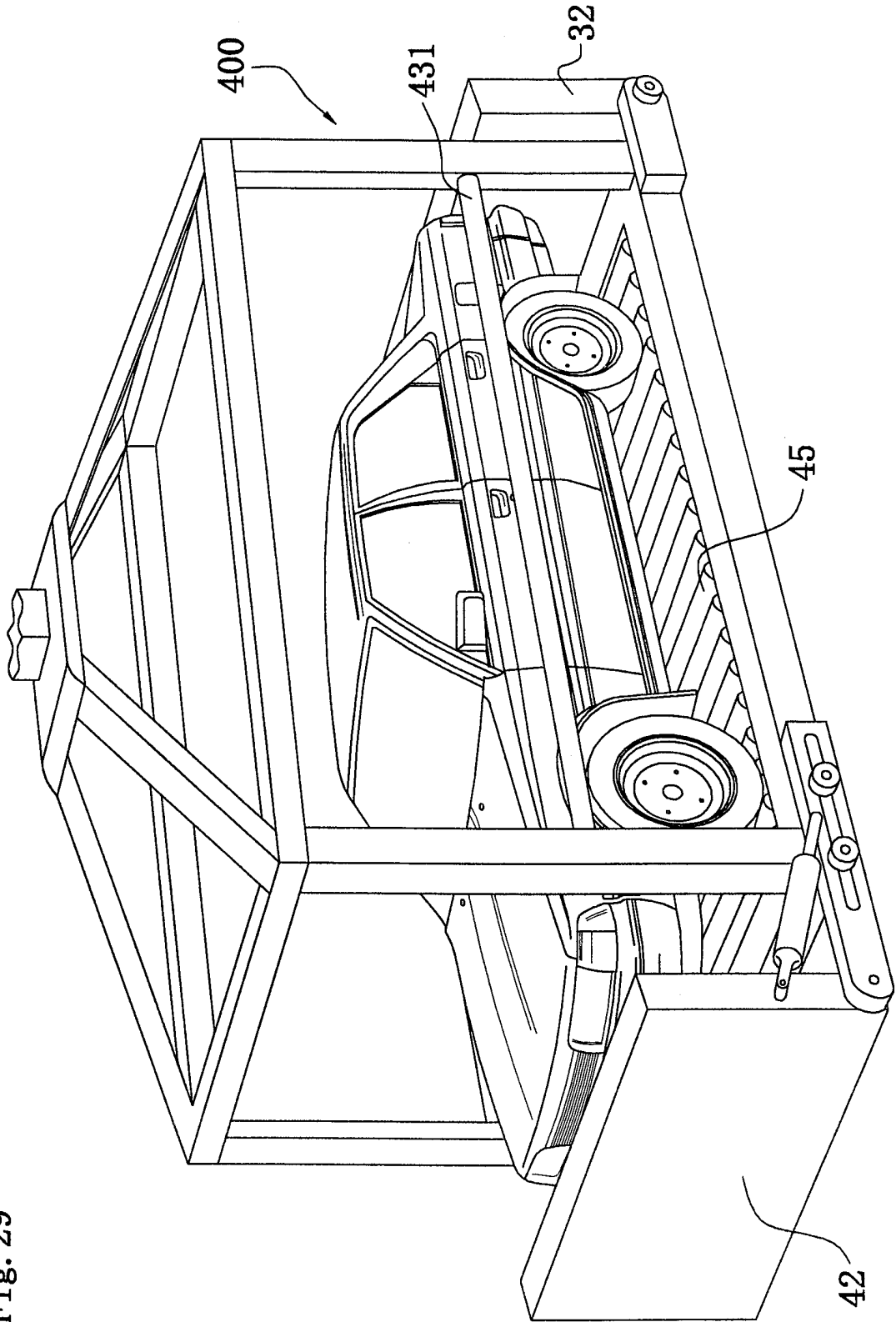
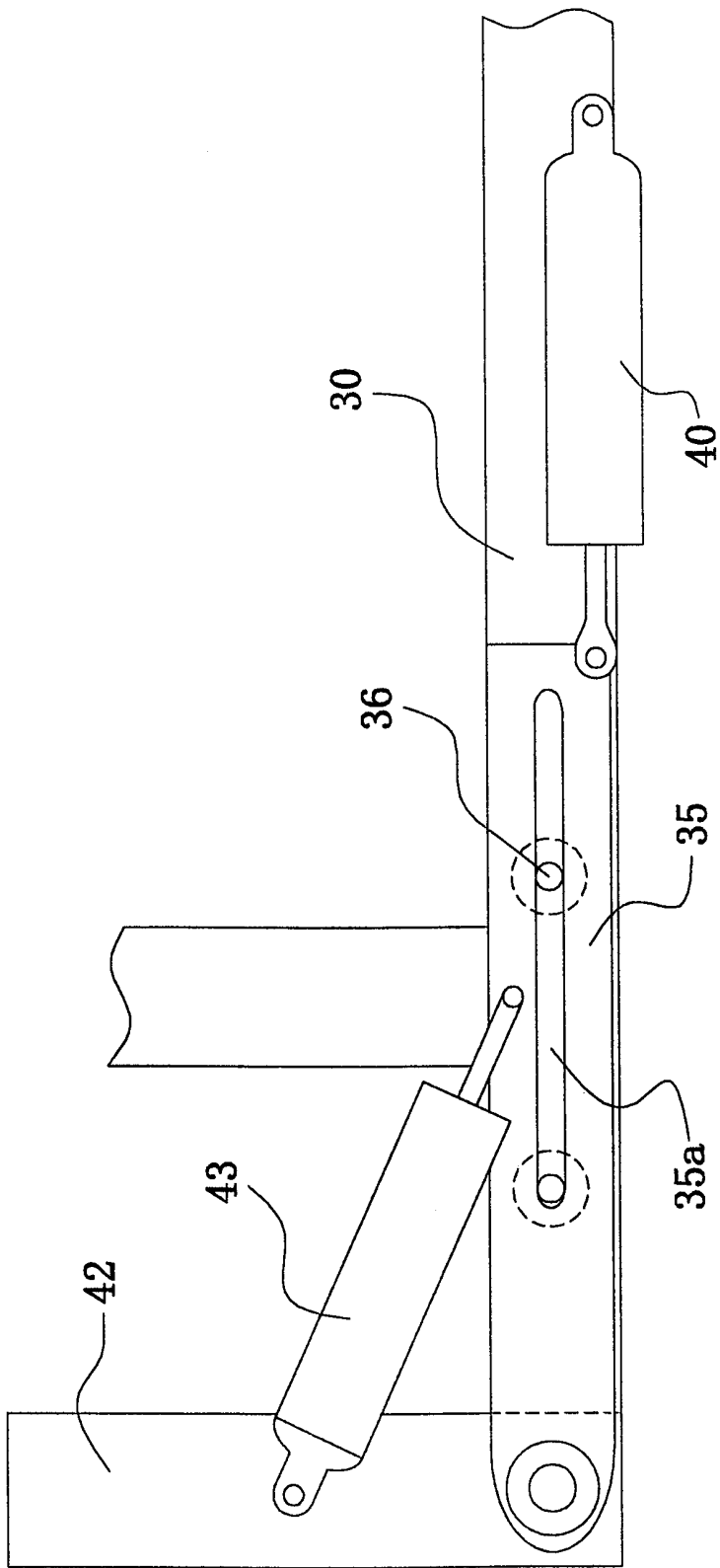

Fig. 29

Fig. 30



INTERNATIONAL SEARCH REPORT

Internat. Application No
PCT/JP 99/04777

A. CLASSIFICATION OF SUBJECT MATTER

IPC 7 A63G31/16

According to International Patent Classification (IPC) or to both national classification and IPC

B. FIELDS SEARCHED

Minimum documentation searched (classification system followed by classification symbols)

IPC 7 A63G

Documentation searched other than minimum documentation to the extent that such documents are included in the fields searched

Electronic data base consulted during the international search (name of data base and, where practical, search terms used)

C. DOCUMENTS CONSIDERED TO BE RELEVANT

Category	Citation of document, with indication, where appropriate, of the relevant passages	Relevant to claim No.
A	US 5 192 247 A (BARR CRAIG K ET AL) 9 March 1993 (1993-03-09) abstract; figures 1-5 ---	1
P,A	US 5 935 011 A (MORGAN DANA H ET AL) 10 August 1999 (1999-08-10) abstract; figures ---	1
P,A	US 5 853 331 A (ISHIKAWA MASAMI ET AL) 29 December 1998 (1998-12-29) abstract; figures ---	18
A	US 5 678 972 A (BOECKLER HANS ET AL) 21 October 1997 (1997-10-21) -----	

Further documents are listed in the continuation of box C.

Patent family members are listed in annex.

° Special categories of cited documents :

- "A" document defining the general state of the art which is not considered to be of particular relevance
- "E" earlier document but published on or after the international filing date
- "L" document which may throw doubts on priority claim(s) or which is cited to establish the publication date of another citation or other special reason (as specified)
- "O" document referring to an oral disclosure, use, exhibition or other means
- "P" document published prior to the international filing date but later than the priority date claimed

- "T" later document published after the international filing date or priority date and not in conflict with the application but cited to understand the principle or theory underlying the invention
- "X" document of particular relevance; the claimed invention cannot be considered novel or cannot be considered to involve an inventive step when the document is taken alone
- "Y" document of particular relevance; the claimed invention cannot be considered to involve an inventive step when the document is combined with one or more other such documents, such combination being obvious to a person skilled in the art.
- "&" document member of the same patent family

Date of the actual completion of the international search

7 January 2000

Date of mailing of the international search report

18/01/2000

Name and mailing address of the ISA

European Patent Office, P.B. 5818 Patentlaan 2
NL - 2280 HV Rijswijk
Tel. (+31-70) 340-2040, Tx. 31 651 epo nl,
Fax: (+31-70) 340-3016

Authorized officer

Godot, T

INTERNATIONAL SEARCH REPORT

...information on patent family members

Intern. Patent Application No

PCT/JP 99/04777

Patent document cited in search report		Publication date	Patent family member(s)	Publication date
US 5192247	A	09-03-1993	WO 9217256 A	15-10-1992
<hr style="border-top: 1px dashed black;"/>				
US 5935011	A	10-08-1999	NONE	
<hr style="border-top: 1px dashed black;"/>				
US 5853331	A	29-12-1998	NONE	
<hr style="border-top: 1px dashed black;"/>				
US 5678972	A	21-10-1997	DE 4227609 A	24-02-1994
			AT 171502 T	15-10-1998
			WO 9404779 A	03-03-1994
			DE 59309014 D	29-10-1998
			EP 0656980 A	14-06-1995
			JP 8500402 T	16-01-1996
<hr style="border-top: 1px dashed black;"/>				