



(43) International Publication Date  
27 February 2014 (27.02.2014)

- (51) International Patent Classification:  
*A61G 7/053* (2006.01) *A61G 7/10* (2006.01)
- (21) International Application Number:  
PCT/GB2013/052226
- (22) International Filing Date:  
23 August 2013 (23.08.2013)
- (25) Filing Language: English
- (26) Publication Language: English
- (30) Priority Data:  
1215012.4 23 August 2012 (23.08.2012) GB
- (71) Applicants: **ARJO HOSPITAL EQUIPMENT AB** [SE/SE]; Verkstadsv. 5, S-241 21 Eslov (SE).  
**HUNTLEIGH TECHNOLOGY LIMITED** [GB/GB]; ArjoHuntLeigh House, Houghton Hall Business Park, Houghton Regis, Bedfordshire LU5 5XF (GB).
- (72) Inventors: **NILSSON, Richard**; Langskeppsgatan 10, S-224 74 Lund (SE). **THOMASSON, Andreas**; Storelidsgatan 52, S-275 31 Sjobo (SE).
- (74) Agent: **THAKER, Shalini**; ArjoHuntLeigh House, Houghton Hall Business Park, Houghton Regis, Bedfordshire LU5 5XF (GB).
- (81) Designated States (*unless otherwise indicated, for every kind of national protection available*): AE, AG, AL, AM, AO, AT, AU, AZ, BA, BB, BG, BH, BN, BR, BW, BY, BZ, CA, CH, CL, CN, CO, CR, CU, CZ, DE, DK, DM, DO, DZ, EC, EE, EG, ES, FI, GB, GD, GE, GH, GM, GT, HN, HR, HU, ID, IL, IN, IS, JP, KE, KG, KN, KP, KR, KZ, LA, LC, LK, LR, LS, LT, LU, LY, MA, MD, ME, MG, MK, MN, MW, MX, MY, MZ, NA, NG, NI, NO, NZ, OM, PA, PE, PG, PH, PL, PT, QA, RO, RS, RU, RW, SA, SC, SD, SE, SG, SK, SL, SM, ST, SV, SY, TH, TJ, TM, TN, TR, TT, TZ, UA, UG, US, UZ, VC, VN, ZA, ZM, ZW.
- (84) Designated States (*unless otherwise indicated, for every kind of regional protection available*): ARIPO (BW, GH, GM, KE, LR, LS, MW, MZ, NA, RW, SD, SL, SZ, TZ, UG, ZM, ZW), Eurasian (AM, AZ, BY, KG, KZ, RU, TJ, TM), European (AL, AT, BE, BG, CH, CY, CZ, DE, DK, EE, ES, FI, FR, GB, GR, HR, HU, IE, IS, IT, LT, LU, LV,

[Continued on next page]

(54) Title: PATIENT REPOSITIONING SYSTEM

Fig. 2

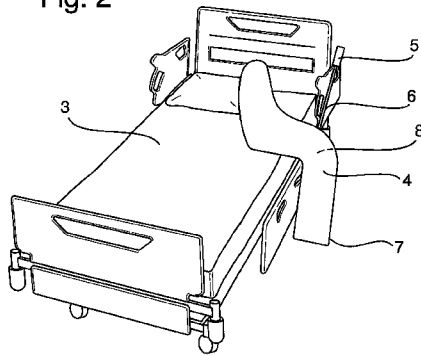
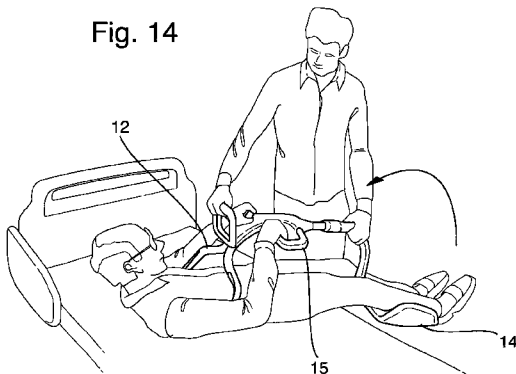

Fig. 14



(57) Abstract: A patient repositioning device includes an upper body support (D) and a lower body support (C) which are generally planar and laterally spaced from one another by a spacing element (E). A handle (5) can rotate in the plane of the supports, enabling a care giver to rotate a patient from a sitting to a lying position and then to roll the patient onto their back. Another embodiment provides a patient cradle (12) for cradling a patient from a reclining to a sitting position and vice versa.

MC, MK, MT, NL, NO, PL, PT, RO, RS, SE, SI, SK,  
SM, TR), OAPI (BF, BJ, CF, CG, CI, CM, GA, GN, GQ,  
GW, KM, ML, MR, NE, SN, TD, TG).

— *as to the applicant's entitlement to claim the priority of  
the earlier application (Rule 4.17(iii))*

**Declarations under Rule 4.17:**

- *as to the identity of the inventor (Rule 4.17(i))*
- *as to applicant's entitlement to apply for and be granted  
a patent (Rule 4.17(ii))*

**Published:**

- *with international search report (Art. 21(3))*

## **PATIENT REPOSITIONING SYSTEM**

The present invention relates to an apparatus and method to aid a care giver in changing posture of a person from sitting to lying at a bed and in particular  
5 to aid a caregiver in helping a person in and out from a bed or similar equipment.

When lying down in bed, the movement of getting the patient's legs up in bed is heavy. The patient may have big difficulties doing this by themselves due to reduced strength. If this manoeuvre is performed by the nurse, she or he is lifting the weight in a difficult height and position.

10 In particular, persons having mobility, strength or other limitations hindering them from coming from a sitting position to a lying position, or vice versa, on a bed will need help to perform this task. At settings where a carer helps to carry out this task daily, be it in a hospital, special care centre or a home and the carer being a nurse or another professional person or a relative to the person to be helped, this  
15 person will be exposed to a number of operations putting their health at risk, such as for example overload of the muscles and/or back. The reasons for the potential risks are several individual factors or combination of factors. For example a difference in length of the person to be helped and the carer will result in non-optimal working posture. Another factor is the difference in weight giving unequal  
20 load between the persons. Factors such as the working height might have severe effects on the carer since it affects the carer's reach and thus possibly making the carer twist their back to compensate. A low working height will lead to a bent back of the carer, resulting in very high loads on the lower back. Another factor affecting the reach comes from the width of the bed and the fact that the legs of  
25 the person to be helped legs have to come from the lying position relatively far in from the edge of the bed and out onto the edge of the bed for the carer to be able to help them down onto the floor and vice versa when coming from a sitting position to a lying position on the bed.

There is also a number of factors affecting the person to be helped that can  
30 have a negative effect. Such factors include, for example, the need to have a straight back during the manoeuvre from sitting to lying or vice versa, which can be hard to maintain without proper technique and/or equipment, also the need to

have the patient's legs and upper body substantially parallel in the sagittal plane, which is hard to maintain without proper technique and/or equipment.

Shear of the skin may also be an issue for the person to be helped if no proper technique and/or equipment are used. The person to be helped may also  
5 be affected by the speed of the transition from sitting to lying or vice versa if it is not timed to the patient's conditions or preferences.

Another factor that can affect the person to be helped is the amount of activity that person contributes with throughout the manoeuvre. If the carer chooses to use a technique and/or equipment that makes the person to be helped  
10 more passive than necessary that will have a negative influence on that person's mobility level progression.

When the person helped has come from the lying position in bed to the sitting position at the edge of the bed, in many cases the person is also in need of help in the sit-to-stand sequence that generally follows.

An important factor of beds intended for persons in settings like elderly care facilities, special care clinics and hospitals or similar, is their ability to reach a very  
15 low position when the person is left unattended, preferable in order to minimize the consequences from an unintentional fall from the bed onto the floor. Another factor is the fact that a bed is a medical device which must meet regulations, and  
20 accessories not sanctioned by the manufacturer may not only hinder the bed's specified functionality but may also compromise the safety of the bed.

Not only are there personal gains in limiting the negative factors, there are also economical as all the negative factors have consequences that can be measured in economic terms, be it for the employer employing the carer having to  
25 reimburse the employee for conditions acquired due to lack of proper working technique and/or equipment provided or the prolonged rehabilitation of a patient that has been passivized.

Various known devices have sought to address the problem of a patient coming from a sitting position to a lying position at a bedside. For  
30 example, US 2004/0019967 – "Assistance apparatus for assisting a person into and out of bed" discloses a device that the patient sits on and, while leaning onto the movable upper frame, their legs are elevated by the lower frame following the

movement of the upper by the powered movement. Some drawbacks with the described device can be noted. It's design around a chassis intends it to be permanently installed adjacent the bed frame, which complicates use together with modern hospital beds that are height adjustable and have safety gates that need to be operable in the same area as the device occupies. With a chassis between the person's calves and the bed it will become even harder to come to the ideal position in the centre of the bed when lying down, since the starting position is further out than without a chassis adjacent to the bed. The person to be helped is also fully dependent on the apparatus in that it is powered in the motion, potentially leading to a more passivized person than needed.

Another device is disclosed in US 2010/0125947 – "Leg Lifting Apparatus", where the person's legs are lifted onto the bed while sitting on the horizontal part of the bed. The device again mainly focuses on an independent person, this time having enough muscular tonus to handle the upper body movement personally. As the device is intended to be permanently mounted to the bed, it can be in conflict with the normal performance of the medical bed and can also be a hindrance to the following sit-to-stand movement if this is carried out with the help of a mobile device such as a sit-to-stand device having a chassis extending partly under the bed.

Yet another device is disclosed in US 6,349,433 "Assembly of a bed and an apparatus for movement support for a person when moving into or out of a bed" where the person is helped with upper body movement by a lever.

Known devices, such a height adjustable beds, are a great help in providing an ergonomic workplace even with people of different length. Such beds are also known to have profiling features, in that they are able to raise the backrest helping the person come up to a more sitting position, and can minimize the physical demands of the carer. This sitting position is in the centre of the bed, facing towards the foot end of the bed and doesn't address the sometimes important need of having the legs and upper body parallel in the sagittal plane when coming from a lying position to a sitting position on the edge of the bed facing out from the beds longer side. Nor gives it any help in getting the legs up into the bed when going from a sitting position at the edge of the bed into a lying position. Another

potential drawback is the fact that the speed of the backrest is fixed and doesn't adapt to the person's specific needs and/or preferences.

Patient lifters such as US 6,557,189 may be able to minimize the load the carer is exposed to in the process of helping a person in coming from a lying  
5 position on a bed and up from the support surface, in that they are lifted in a sling with motorized help. The device may also re-position the person to a sitting position and deliver the person down to the edge of the bed. The biggest drawback of using this kind of device for this sort of manoeuvre is that the person helped out of the bed is forced to be very passive in this manoeuvre. Secondly, it  
10 is a very time consuming process.

The prior art devices can also have the drawback of being awkward to use with other patient transfer devices, such as a Sit-to-Stand device.

The present invention seeks to provide an improved patient repositioning device and method.

15 According to an aspect of the present invention, there is provided a patient repositioning device for assisting in the movement of a patient, the device including a support unit provided with a generally planar upper body support coupled to a generally planar lower body support, the upper and lower body supports being substantially coplanar to one another and being  
20 laterally spaced from one another, and at least handle or grip coupled to the support unit and substantially rigid in a direction perpendicular to the plane of the upper and lower body supports.

Preferably, the support unit includes a lateral support coupled between the upper and lower body supports and separating the upper and lower body  
25 supports laterally. The lateral support may be an extension of one or both of the upper and lower body supports and may be in the form of a single or plurality of beams or a torsion spring.

Advantageously, the handle or grip provides torque transfer in at least two different directions.

30 In one embodiment, the handle or grip is rotatable between first and second orientations in a plane substantially parallel to the support unit.

In another embodiment the handle extends in at least two different directions in a plane substantially parallel to the plane of the support unit.

The handle may be integral with at least one of the body supports and the lateral support.

5 There may be provided a plurality of handles, which may be disposed at respective ones of the upper, lateral and lower supports.

In an embodiment, the handles are formed by apertures or slots in the supports or an enlarged head grip.

10 Preferably, there is also provided a patient grip. The patient grip may include a handle located on a strut, the handle extending at an angle to the plane of the support unit. The strut and patient handle preferably extend substantially perpendicular to the plane of the support unit.

In one embodiment there is provided a plurality of patient grip elements disposed at varying distances from the support unit. In another 15 embodiment the patient grip is disposed on an extendable strut.

Preferably, the support unit is provided with rounded or resilient edges.

20 Advantageously, the upper body support and the lower body support are disposed at a shallow angle to one another; for instance a few degrees up to around 10 degrees or even up to around 20 degrees.

The lower body support may include an angled foot rest at a lower end thereof.

25 In some embodiments at least the body supports are curved or conformable to a curve. They may, for instance be curved to follow the curves of the side of a person or be of compressible or otherwise conformable material to be able to conform to the shape of the patient.

30 According to another aspect of the present invention, there is provided a patient cradle for assisting in the movement of a patient including an upper body support, a lower body support, a support yoke and at least one handle or grip on the yoke, the yoke allowing for cradling of a patient between a lying and an upright position.

The cradle preferably provides a space between the upper and lower body supports, allowing a patient to bend therebetween from a lying to a sitting position. Typically this is achieved by supporting the patient's torso and calves only.

5 The cradle preferably first and second handles or grips spaced from one another along the yoke. The or at least one of the grip or handle is located on the yoke in a patient balanced position.

Advantageously, there is provided at least one patient gripping element.

10 The preferred embodiments are able to address the various considerations for bringing a patient from a sitting to a lying position and vice versa and without the disadvantages of the prior art.

The herein disclosed devices can allow the caregiver to work in an ergonomically good way with the manoeuvres required to help a person coming  
15 from a lying position in bed to a sitting position at the longer edge of the same bed and vice versa while maintaining the helped person maintain their legs and upper body generally parallel in the sagittal plane throughout the manoeuvre. As it allows for the person to be helped to contribute as much or as little as achievable, it doesn't contribute to the patient being passivized. The caregiver can also adapt  
20 the speed of the manoeuvre to the given situation, in that the device is manoeuvred preferably by hand and in direct contact with the person to be helped. The device allows the caregiver to position the person in the middle of the bed after the legs have been lifted up onto the bed and the upper body laid down onto the bed, without the need to reach and/or bend her body excessively in that the  
25 device extends the care giver's working range. As the preferred device is portable and only temporarily used at the bed it also facilitates the pre- and post-activities and the use of other equipment, for example a Sit-to-Stand device, in that it does not remain in the way of those other devices. This also ensures that the bed can be used as originally specified and without compromising any safety related  
30 aspects of it.

As the preferred apparatus is non-powered, lightweight, portable, easy to understand, one size and designed to have a low manufacturing cost, it is

expected to have a good impact on the working conditions of care givers, on patient outcome and health economics.

The preferred device can work as a see-saw, where the person to be laid down sits on the longer edge of a bed's horizontal part and, leaning their left or right side with legs dangling off the side of the bed, positions their upper body to the upper part of the device and their legs to the lower part of the device, with their legs and upper body generally parallel in the sagittal plane. While the caregiver holds the device in the correct place against the person to be laid down, by means of at least one handle on the device to hold onto ,the caregiver initializes the movement by tilting the device towards the side on which the person to be helped is going to have their head when lying down. The person to be laid down follows the movement and the heavier upper body brings a positive torque or moment to the device driving her legs up in the same movement given that the device is predominately rigidly connected between its upper and lower parts. The caregiver can moderate the speed of the movement by adding a counteracting torque or force to the device, specifically applying force in opposite direction to the rotation. When the person lies down with their upper body parallel to the bed's horizontal support surface. the second stage is initialized by the caregiver, by holding onto the leg part of the device and tilting this away. This enables the patient to be shifted from the sagittal plane in a predominately horizontal position into a predominately vertical position and by that comes from a position mainly close to the longer edge of the bed into mainly the centre part of the bed, now on their back with slightly bent legs. In this position the person can be brought to a complete lying position by straightening out the patient's legs, either by themselves or with help from the caregiver after the caregiver has removed the device from the close proximity of the patient.

The reverse workflow will bring a person who is lying down on the bed to a sitting position at the longer edge of the bed's horizontal part. The reverse workflow has one main difference, in that as the upper body of the person to come into a sitting position is heavier than the legs, the caregiver will have to apply a greater force of torque to the device when rotating the person from the lying to the sitting position as compared to the reverse manoeuvre.

Another way of operating the device can be achieved by incorporating the functionality of some beds having a power adjustable back-rest, letting the bed's power adjustable back-rest add the required force or torque when rotating the person from the lying to the sitting position or vice versa. In this way the caregiver just need to apply sufficient force for guiding the device through this sequence.

Yet another way of operating the device can be achieved by the caregiver instructing the person to be seated to add the required force or torque by pressing away from the bed with one hand and at the same time holding onto the device with the other hand. In this way the caregiver just needs to apply sufficient force for guiding the device through this sequence.

Nurse benefits include: reducing unsafe manual handling and not having to bend down and lift heavy legs in to bed.

Patient benefits include: a more gentle way of lying down on to bed since the twisting between the upper and lower body is eliminated in the movement from sitting to lying.

Thus, the preferred apparatus allows a care giver to reposition a person, for example and hereafter called a patient, from a sitting position on the edge of the bed frame to a lying position on the bed with minimal effort. The patient sits on the edge of the bed frame facing out from the longest side of the bed, while she is leaning her upper body to the side, towards the upper part of the apparatus, the apparatus, while guided by the care giver, lifts her legs up in a way that her body, seen from front, forms a predominantly straight line during the movement of her upper body towards a lying position on the horizontal bed frame top.

As the patient to be repositioned is supported by the disclosed apparatus for the upper body as well as for the legs, the loads on muscles are minimized, as are pain. Not only the patient gains from this apparatus, as it is a significant source for back pain for care givers helping patients onto beds, where getting the feet up from the floor onto the bed puts a lot of strain on their back. Care givers will be able to assist patients in a much more ergonomically correct position with the help of this apparatus and technique.

The herein disclosed apparatus can also allow the caregiver, in an intuitive way, to help a patient to get to their feet up onto a bed without any need for electrically manoeuvred apparatus. Also the apparatus can allow usage of additional patient transfer devices in that it will be out of the way from the area in front and under the bed which traditionally are used by patient transfer devices such as Sit-to-Stand devices.

Embodiments of the present invention are described below, by way of example only, with reference to the accompanying drawings, in which:

Figures 1 to 5 show in schematic form a sequence of placing a patient onto a bed by means of an embodiment of patient repositioning system as taught herein;

Figure 6 shows front and side elevational views in schematic form of a handle for the patient repositioning system of Figures 1 to 5;

Figure 7 shows front and side elevational views in schematic form of another handle for the patient repositioning system of Figures 1 to 5;

Figures 8 and 9 show another embodiment of patient repositioning system;

Figures 10 to 12 show in schematic form a sequence of placing a patient onto a bed by means of the patient repositioning system of Figures 8 and 9; and

Figures 13 to 15 show an embodiment of patient cradle.

Referring to FIGURE 1 is shown the predominately horizontal surface (3) of a bed hereinafter the top. The illustration shows a hospital bed but it is to be understood that it could also represent a couch, a stretcher, an examination table, an operation table or any other surface that a person normally would sit on to before lying down onto the same. The patient's (1) starting position is sitting on the longer edge of the top of the surface (3) prior to lying down, facing upwards. The care giver (2) places the mobile patient support (4) adjacent one side of the patient (1), specifically on the same side of the patient (1) as the patient (1) is to lean in order to reach the final lying position on the top (3) of the bed. The contact surface of patient support (4) is preferably made of a material and structure that gives comfort to the patient (1), for example but not limited to, polypropylene, wood, polyurethane,

combinations of these or any other suitable materials. The contact surface of the support (4) may be padded for added comfort and/or slightly curved.

Referring to FIGURES 2 and 6, there is shown the apparatus prior to positioning by a patient. AS can be seen, the apparatus includes means for the care giver (2) to hold onto, in this embodiment being in the form of a handle (5) securely connected by an arm (6) to a coupling or pivot point (8) which allows rotation around an axis predominately perpendicular to the patient contact surface (4), allowing the handle (5) and arm (6) to be positioned predominately parallel to the edge (7) of the patient contact surface (4) or predominately perpendicular to the edge (7) of the patient contact surface (4) or at any angle in between. The arrangement with the rotatable coupling point (8), the arm (6) and the handle (5) provides a lever for the care giver (2) to aid in the task of tilting around axis A and respectively axis B as shown in FIGURE 6.

Referring to FIGURE 6 the patient support (4) has a portion (C) shaped and sized to support the legs of a patient (1) and a portion (D) shaped and sized to support the upper body of the patient (1). Portion (D) is preferably generally parallel with portion (C) and most preferably substantially coplanar. The two portions (C) and (D) may be separated, if found suitable, by a lateral portion (E) providing lateral separation of portions (C) and (D). Portion (E) may be an extension of portion (C) or (D) or both, but could also be in the form of, for example but not limited to, a single or plurality of beams, a torsion spring with sufficient force to enable the function of the apparatus as described before.

The patient support surface (4) may be flat or given a shape conforming or conformable to the shape of the side of a patient (1) which it is intended to support. Preferably, the patient support surface (4) is equivalent on both sides of the apparatus, giving it a longitudinal symmetrical appearance, illustrated by the two opposite facing patient supporting surfaces (4) in FIG 6, thus to enable the apparatus to be used from either side of a patient (1), thereby to aid in getting into a bed from one side or the other.

It is to be understood that the arrangement with the rotatable coupling point (8), the arm (6) and the handle (5) could be designed in other ways while still aiding the care giver (2) in the task of tilting around axis A and respectively axis B in the manner depicted in FIGURE 6. One such  
5 configuration is shown in FIGURE 7 where an edge profile (9) is rigidly connected (10) with the patient contact surface (4), thus providing a lever for the care giver (2) to aid in the task of tilting around axis A and respectively axis B.

Referring now to FIGURE 3 the care giver (2) gently guides the patient  
10 (1) to lean with their upper body against the patient support surface (4), causing it to tilt about axis A. The weight of the patient's (1) upper body onto the upper part of the patient support surface (4), together with assistance from the care giver (2) applying force on the handle (5), rotates the lower part of the patient support surface (4) about axis A and causes the patient's  
15 (1) legs to rise from a predominately vertical position towards a predominately horizontal position parallel to the surface (3).

Referring to FIGURE 4 the care giver (2) then alters the position of the handle (5) from being predominately parallel to the edge (7) to being  
predominately perpendicular to the edge (7) in order to provide a lever aiding  
20 in in the task of rotating the patient support surface (4) about axis B so as to position the patient's (1) back against the surface (3) of the bed, along with the patient's (1) feet as illustrated in FIGURE 5.

Another embodiment of patient repositioning support is shown in  
Figures 8 to 12.

Referring first to FIGURE 8, the device includes a portion B1 shaped and  
25 sized to support the legs of the person or patient to be helped and a portion B1 substantially parallel to portion D1 sized and shaped to support the upper body of the patient. The two portions B1 and D1 are preferably laterally separated to approximately fit the silhouette of an sitting person seen in the sagittal plane. In  
30 this regard, portion C1 may be an extension of area B1 or D1 or both, but could also be in the form of, for example but not limited to, a single or plurality of beams,

a torsional spring with sufficient rigidity to enable the function of the apparatus as described before.

The patient support surface portions B1, C1 and D1 may be flat or have a shape to conforming or conformable to the patient's body. For example, the  
5 outmost part or side of the portion B1 near the patient's feet could be slightly inclined as shown in Figure 10. Preferably the patient support portions B1, C1 and D1 have symmetrically opposing sides surfaces B2, C2 and D2 to be enable the device to be used from either side, thus enabling the single device to be used at a bed from one side or the other.

10 As the device's contact surfaces B1/B2, C1/C2 and D1/D2 are designed to be in close contact to the patient's body, they are preferably made of a material and/or structure that gives comfort to the patient , for example but not limited to, polypropylene, wood, polyurethane, combinations of them or any other suitable materials characterized in being rigid enough to support the weight of the upper  
15 body and legs of the patient yet comfortable. They may have a soft covering.

The device is intended to be rotated about the predominately horizontal axis X-X when bringing the patient from a lying to a sitting position or vice versa. Preferably the device includes gripping means which in this example is in from of one or several handles 3 located at or proximate the edge 5 of patient support  
20 portion D1/D2. The handle/s may be in the form of aperture/s in the support portion D1/D2, the edge 5 forming a handgrip that is suitable to grip around by the person helping the patient. Preferably, the handle 3 is located a distance from the axis X-X to form a lever to minimize the force needed to be applied by the caregiver to bring the patient from a lying position into a sitting position and in the  
25 same time being suitable for the range of motion of the caregiver.

Another example of grip forms the edge 5 itself into a grip as seen in Figure 9, where the edge 5 has an enlarged head 3 facilitating grip of the fingers of the caregiver to the device. The described examples are not limiting, several other ways of providing suitable grips may be realized by the skilled person, for example  
30 but not limited to, ropes and or webbing attached to the device, spherical formed extensions from the portion D1/D2, etc.

To bring the device in rotation around the axis X-X, yet another point of grip 21 is preferably provided. The grip point 21 is preferably located spaced from the first handle/s 3 in order for the caregiver to be able to use both hands to add force contributing to the rotational movement and having a distance from the axis X-X to form a lever 23 to minimize the force needed to be applied by the caregiver to bring the patient from a lying position into a sitting position and in the same time being suitable for the range of motion of the caregiver. Preferably, the grip point 21 is located somewhere along a strut extending from the portion C1/C2 and not parallel to portion C1/C2. To provide an grip point 21 having a suitable distance from the axis X-X to suit different caregivers statute or different patient weights, the strut may be telescopic or provided with a multitude of grip points 21. Along the strut and preferably between the grip point 21 and the portions B1, C1 there is preferably provided a place or handle 20 for the patient to hold onto. Preferably the handle 20 is formed to accommodate at least one of the patient's hands, thereby enabling the patient to hold onto the device.

To enable a single device to be used at a bed from one side or the other, the member 23 preferably has two mirror inverted positions about a plane parallel to the portions B1, C1 and D1, illustrated by the first position A1 and the second mirror inverted position A2. The member 23 is rotatably or flexibly attached to the device by a joint 22 allowing it to move between the two positions A1 and A2, with reference to a plane perpendicular to the axis X-X. The movement may take a path parallel to this plane or a path perpendicular to this, or any other path in between the two. Preferably, the pivotable or flexible joint 22 may transform into a rigid joint when desired or have two end positions characterized by the member 23 being supported by said end position to work as a lever when applying force to the engagement point 21 to bring the device in rotation around axis X-X. In one of several possible embodiments, the joint 22 may be adjusted from a rotatable or flexible configuration to a rigid configuration by actuation of a locking pin on member 23, passing into a corresponding recess in joint 22. In another embodiment the flexible joint 22 may be adjusted from a rotatable or flexible configuration to a rigid configuration by application of a force on the member 23 exceeding a holding force in the joint 22, the holding force in joint 22 resulting

from, for example friction, a spring loaded ratchet mechanism or similar device. The proposed embodiments of the joint 22 just serve as examples and several other ways of providing suitable solutions will be apparent to the skilled person having regard to the teachings herein.

5           When a patient is to be brought in rotation around the transverse plane, that is to be rotated when sitting or lying near the edge of the longer side of the supporting surface of a bed towards the middle of the bed, the device is able to rotate around the predominately horizontal axis Y-Y. To facilitate this, the device preferably also includes gripping means in from of one or several handles 1, 2  
10   about the edge 4 of patient support portion B1/B2. The handle/s may be in the form of aperture/s in the support portion B1/B2 in that the edge 4 forms a shape that is suitable to grip around by the caregivers. Preferably, the handle/s 1, 2 are located a distance from the axis Y-Y to form a lever to minimize the force needed to be applied by the caregiver to rotate the patient about the transverse plane.

15           The edge or edges 6 of the device are designed to cooperate with the support surface of the mating equipment, in this example the mattress of a bed, without damage to the surface. In one embodiment, the edge or edges 6 may be made of a flexible material, for example but not limited to, polyurethane, neoprene or hollow formed polypropylene. In another embodiment the edge or edges 6 may  
20   be predominately stiff and given a rounded shape. The proposed embodiments of the edge or edges 6 just serve as examples, as several other ways of providing suitable solutions will be apparent to the skilled person having regard to the teachings herein.

          Referring now to FIGURE 10, the device is shown aiding a person, the  
25   patient 40, from a lying position to a sitting position. The patient's body 40 is in contact with the device in that the upper body resting on the device portion D1, the legs rest on portion B1 and the patient's pelvis rests on portion C1. When lying down the portion D1 and the patient's upper body are supported by the predominately horizontal surface 50 of the bed. The illustration shows a hospital  
30   bed but it is to be understood that it could also represent a couch, a stretcher, an examination table, an operation table or any other surface that a person normally would rest upon. The patient's 40 legs are supported by the device portion B1,

both being outside the horizontal support surface 50 ready to raise the patient and would typically also be the case when the patient is being moved from a sitting position to a reclining position. The portion C1 is stiff enough to keep the patient's 40 legs and upper body substantially parallel in the sagittal plane and the device will not introduce any unwanted twisting on the patient's body. For the patient 40 to feel safe and secure the patient can hold onto the handle, which is at least rigid in the direction towards and away from the patient 40 when the patient 40 is in contact with the surfaces B1, C1 and D1 or B2, C2 and D2.

To bring the patient 40 from the lying position to a sitting position the device is rotated around the axis X-X. Since the upper body of the patient in most cases is heavier than the legs, an assistive force is applied to rotate the device and patient 40 upwardly. The device will function as a see-saw rotating around the portion C1/2 and the pelvis of the patient 40, both supported by the surface 50, with the legs of the patient 40 contributing with force F1. The caregiver will contribute a force F2 to bring the device and the patient up to a sitting position. The caregiver 30 can apply the force F2 at a single position or at multiple positions, where the force F2 will be divided into multiple lower forces. The force F2 will be inversely proportional to the distance to the axis X-X. For this purpose, preferably the caregiver 30 uses the grip point 21 which is rigidly connected to portion C1/2 and a second point 3 spaced from the first grip point 21 and still providing a long enough lever relative to the axis X-X and at the same time providing a convenient grip for operation. The structure enables the caregiver 40 to steer the device manually while remaining in close contact with the patient 30, thereby being able to observe and attend to the needs of the patient 40 and regulate the speed of operation. Another way to add the force F2 can be realized with beds that have articulated support surfaces 50, in that the backrest raise function may be activated to bring the device in rotation around axis X-X. In such an event, the caregiver 30 can aid in the rotation of the device by holding on to it via any of the provided support points, for example 21 and or 3, giving it stability and being ready to add needed force and range of rotation motion as the articulated support surfaces 50 of the backrest will not necessarily have the range of motion needed for a complete transfer to a sitting position of the patient 40.

When the device have been rotated, typically a quarter of a turn around the axis X-X, by the weight of the patient's legs and the aid from the caregiver and/or the aid of the articulated frame of the bed, the patient 40 will come to a sitting position on the edge of the support surface 50. In this position the caregiver 30  
5 may effortlessly remove the device after ensuring the patient 40 has released their optional grip on the handle 20. Once the device have been removed from contact with the patient 40 and is no longer in close proximity to the bed, there will no longer be any additional device at the bed hindering integration with other activities or medical equipment.

10 The procedure to go from a sitting position to a lying position is the reverse of the above described procedure.

Referring to FIGURE 11 the device can be used for displacing a patient 30 from a lying position near the longer edge of the support surface 50 into a more central position of the support surface 50 and onto their back while maintaining her  
15 legs and upper body parallel in the sagittal plane. By tilting the device around the axis Y-Y away from the caregiver 40 the patient 30 rolls over onto their by being pushed by the portions B1, C1 and D1. Preferably, the caregiver 40 will hold onto the device in one or several positions, by example there may be a handle 2 for the left hand and a handle 1 for the right hand, while the patient 30 can hold onto the  
20 provided handle 20. As the caregiver 40 will typically manually steer the device in close contact with the patient 30, the care giver is able to adjust the speed and force of movement to the needs of the patient 30 when performing the manoeuvre. When the patient 30 has been turned to their back and has released their grip of the handle 20, the caregiver 40 can remove the device. The support surface 50  
25 and bed-frame are then free from the device, allowing it to be used as intended without interference by the device.

Referring to FIGURE 12 the device can also be used for displacing the patient 30 from a predominately central position of the support surface 50 lying onto their back onto their side near the longer edge of the support surface 50,  
30 ready to be transferred to a sitting position by aid of the device and the caregiver 40. To maintain the legs and upper body parallel in the sagittal plane the caregiver 40 places the device into close contact to the patient's 30 body and such

that the patient's shoulder abuts surface D1, the hip abuts surface C1 and the knees abut surface B1, or B2, C2 and D2 depending on side of the bed. In order for the knees to abut surface B1 they may need to be raised up from the support surface 50. Preferably the caregiver 40 will aid the patient 30 in this manoeuvre  
5 by raising the patient's knees while at the same time guiding the patient's feet along the support surface 50 to minimize friction. The patient 30 may be told or guided by the caregiver 40 to hold onto the handle 20 with at least one hand. The device and the patient 30 are then tilted around the axis Y-Y towards the caregiver 40 with the caregiver holding onto the patient 30, gently pressing the patient  
10 against the device. The caregiver 40 can at any moment, as the situation dictates, shift one or both of the patient's points of contact to another or any suitable point on the device, preferably any of the provided grips, for example grip 1 to guide the device and the patient. As that the caregiver 40 manually steers the device in close contact with the patient 30, the caregiver she is able to adjust the speed and  
15 force of the movement to the needs of the patient 30 when performing the manoeuvre. When the patient 30 and the device have rotated approximately a quarter of a turn around the axis Y-Y the patient 30 comes to a lying position partly supported by the device portions B1, C1 and D1 and partly by the support surface 50, ready to be brought into a sitting position as described in earlier sections.

20 Another method of helping a patient to get to their feet is by using a see-saw device as shown in FIGURES 13 and 14. The device can also be used in combination with a ceiling lift (not shown) as shown in FIGURE 15.

As seen in these Figures, the device (12) is placed in front of the patient with a sling (13) to support the back. The lower end (14) is placed  
25 under the patient's legs and the patient is asked to grip the handles (15) midway of the device. The carer (FIGURE 13) or the ceiling lift (FIGURE 15) is then able to position the patient to lie down on the bed or vice versa. The patient will rock or cradle between the lying and upright positions.

All optional and preferred features and modifications of the described  
30 embodiments and dependent claims are usable in all aspects of the invention taught herein. Furthermore, the individual features of the dependent claims, as

well as all optional and preferred features and modifications of the described embodiments are combinable and interchangeable with one another.

The disclosures in the British patent application from which this application claims priority, and in the abstract accompanying this application are incorporated  
5 herein by reference.

**CLAIMS**

1. A patient repositioning device for assisting in the movement of a patient, the device including a support unit provided with a generally planar upper body support coupled to a generally planar lower body support, the upper and lower body supports being substantially coplanar to one another and being laterally spaced from one another, and at least handle or grip coupled to the support unit and substantially rigid in a direction perpendicular to the plane of the upper and lower body supports.

10

2. A patient repositioning device according to claim 1, wherein the support unit includes a lateral support coupled between the upper and lower body supports and separating the upper and lower body supports laterally.

15

3. A patient repositioning device according to claim 2, wherein the lateral support is an extension of one or both of the upper and lower body supports.

20

4. A patient repositioning device according to claim 2, wherein the lateral support is in the form of a single or plurality of beams or a torsion spring.

25

5. A patient repositioning device according to any preceding claim, wherein the handle or grip provides torque transfer in at least two different directions.

30

6. A patient repositioning device according to any preceding claim, wherein the handle or grip is rotatable between first and second orientations in a plane substantially parallel to the support unit.

7. A patient repositioning device according to any one of claims 1 to 5, wherein the handle extends in at least two different directions in a plane substantially parallel to the plane of the support unit.

5 8. A patient repositioning device according to any one of claims 1 to 5, wherein the handle is integral with at least one of the body supports and the lateral support.

9. A patient repositioning device according to any preceding claim,  
10 including a plurality of handles.

10. A patient repositioning device according to claim 9, wherein the plurality of handles are disposed at respective ones of the upper, lateral and lower supports.

15

11. A patient repositioning device according to claim 9 or 10, wherein the handles are formed by apertures or slots in the supports or an enlarged head grip.

12. A patient repositioning device according to any preceding claim,  
20 including a patient grip.

13. A patient repositioning device according to claim 12, wherein the patient grip includes a handle located on a strut, the handle extending at  
25 an angle to the plane of the support unit.

14. A patient repositioning device according to claim 13, wherein the strut and patient handle extend substantially perpendicular to the plane of the support unit.

30

15. A patient repositioning device according to any one of claims 12 to 14, including a plurality of patient grip elements disposed at varying distances from the support unit.

5 16. A patient repositioning device according to any one of claims 12 to 14, wherein the patient grip is disposed on an extendable strut.

17. A patient repositioning device according to any preceding claim, wherein the support unit is provided with rounded or resilient edges.

10

18. A patient repositioning device according to any preceding claim, wherein the upper body support and the lower body support are disposed at a shallow angle to one another.

15 19. A patient repositioning device according to any preceding claim, wherein the lower body support includes an angled foot rest at a lower end thereof.

20. A patient repositioning device according to any preceding claim, wherein the body supports are curved or conformable to a curve.

20

21. A patient cradle for assisting in the movement of a patient including an upper body support, a lower body support, a support yoke and at least one handle or grip on the yoke, the yoke allowing for cradling of a patient between a lying and an upright position.

25

22. A patient cradle according to claim 21, wherein there is a space between the upper and lower body supports, allowing a patient to bend therebetween from a lying to a sitting position.

30

23. A patient cradle according to claim 21 or 22, including first and second handles or grips spaced from one another along the yoke.

24. A patient cradle according to claim 21, 22 or 23, wherein the or at least one of said grip or handle is located on the yoke in a patient balanced position.

5

25. A patient cradle according to any one of claims 21 to 24, including at least one patient gripping element.

10

Fig. 1

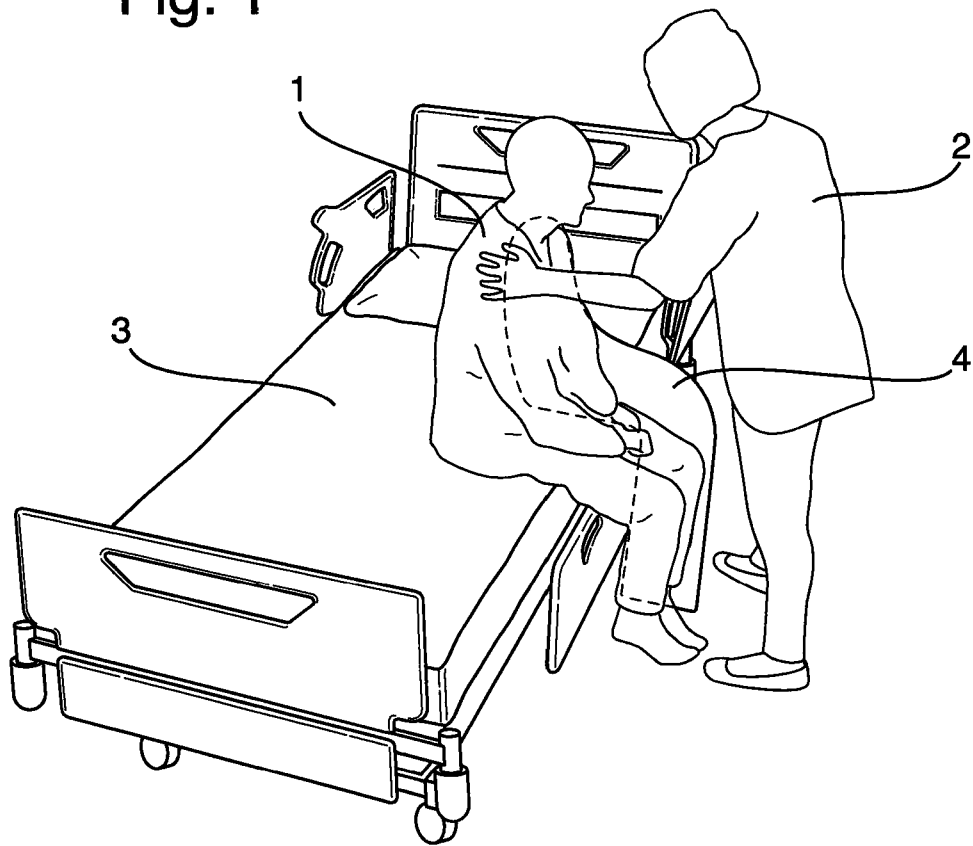
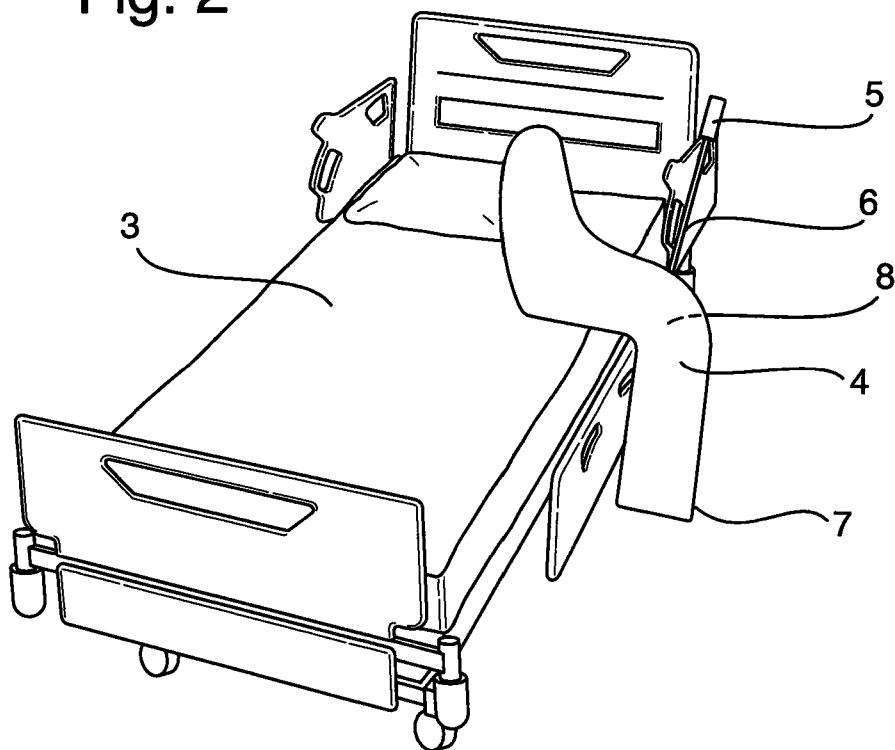

Fig. 2



2/8

Fig. 3

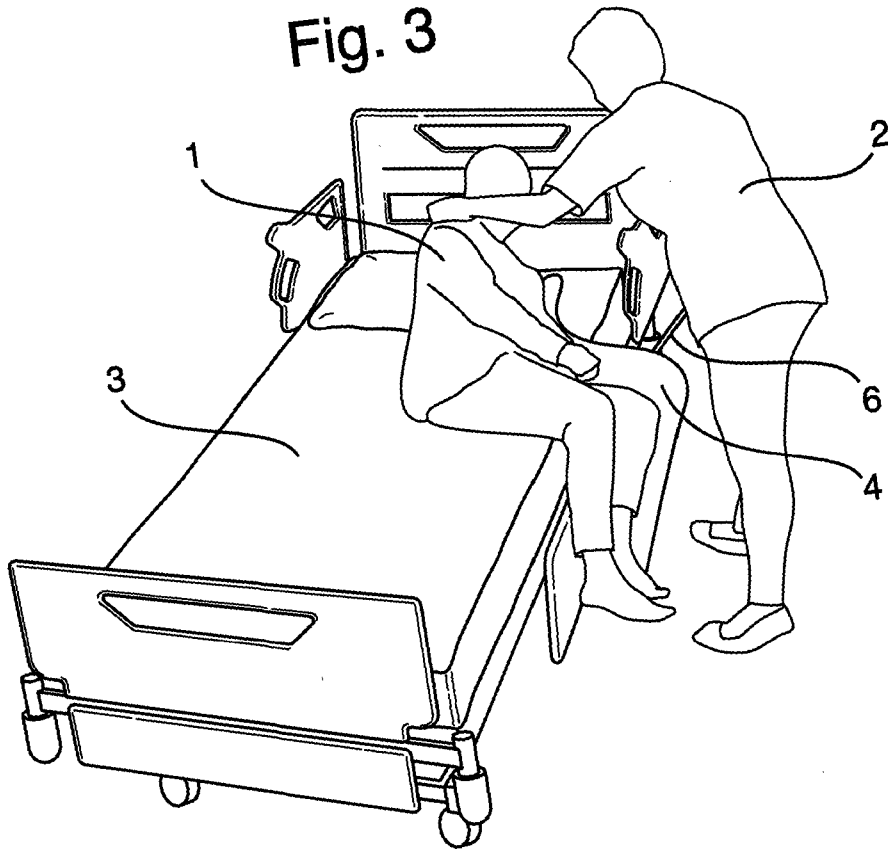
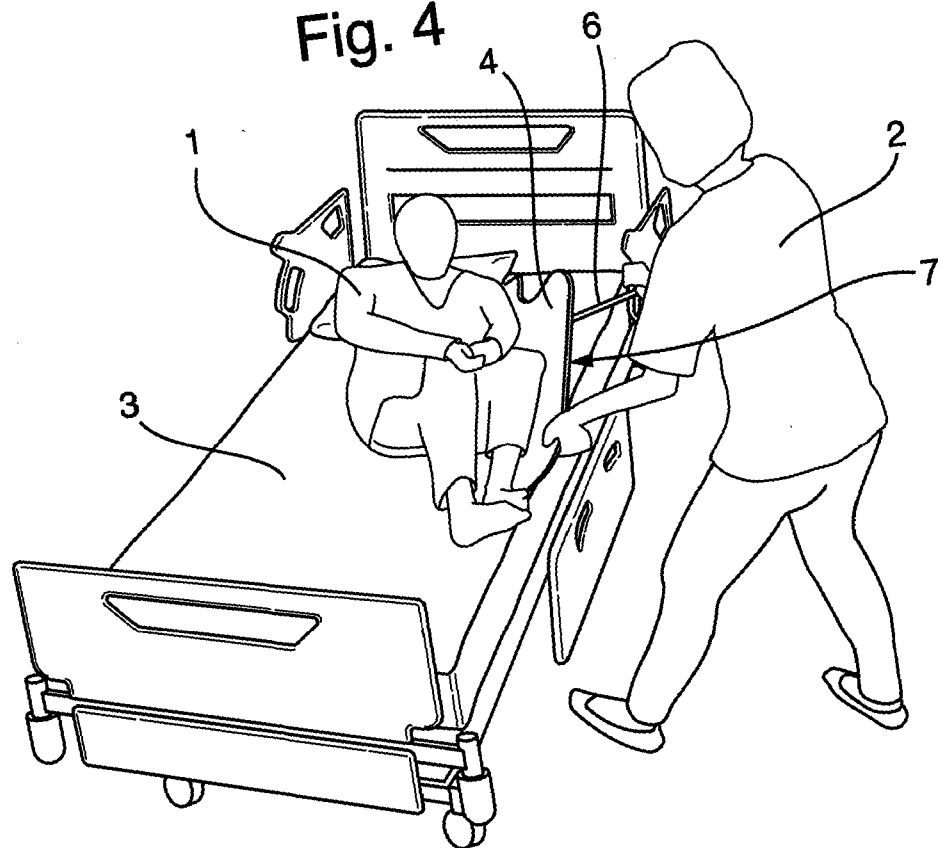

Fig. 4



3/8

Fig. 5

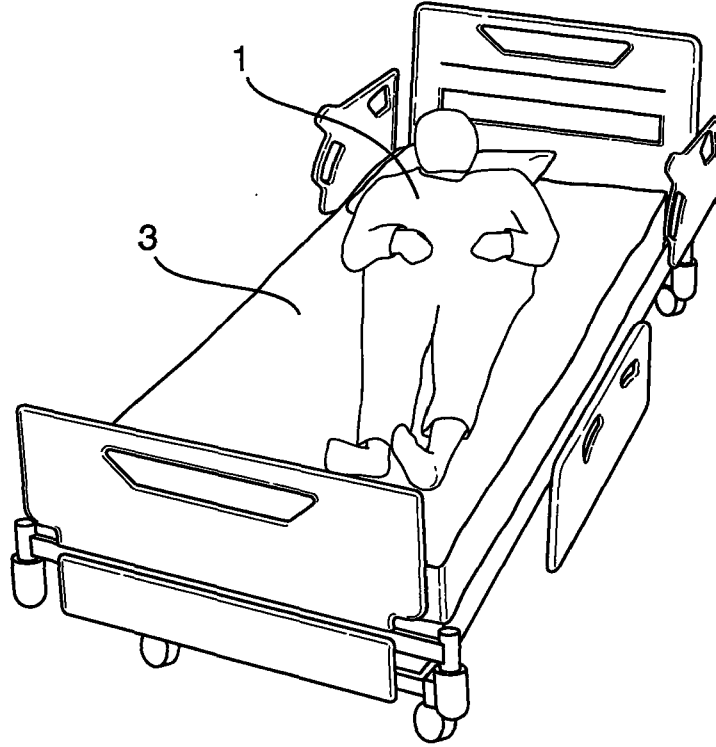
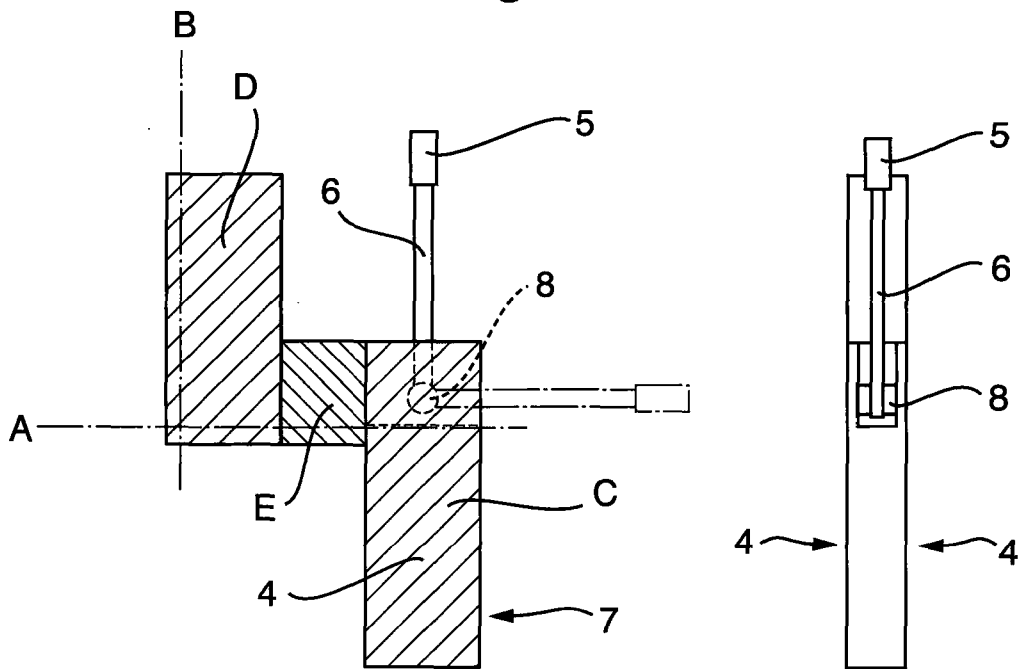

Fig. 6



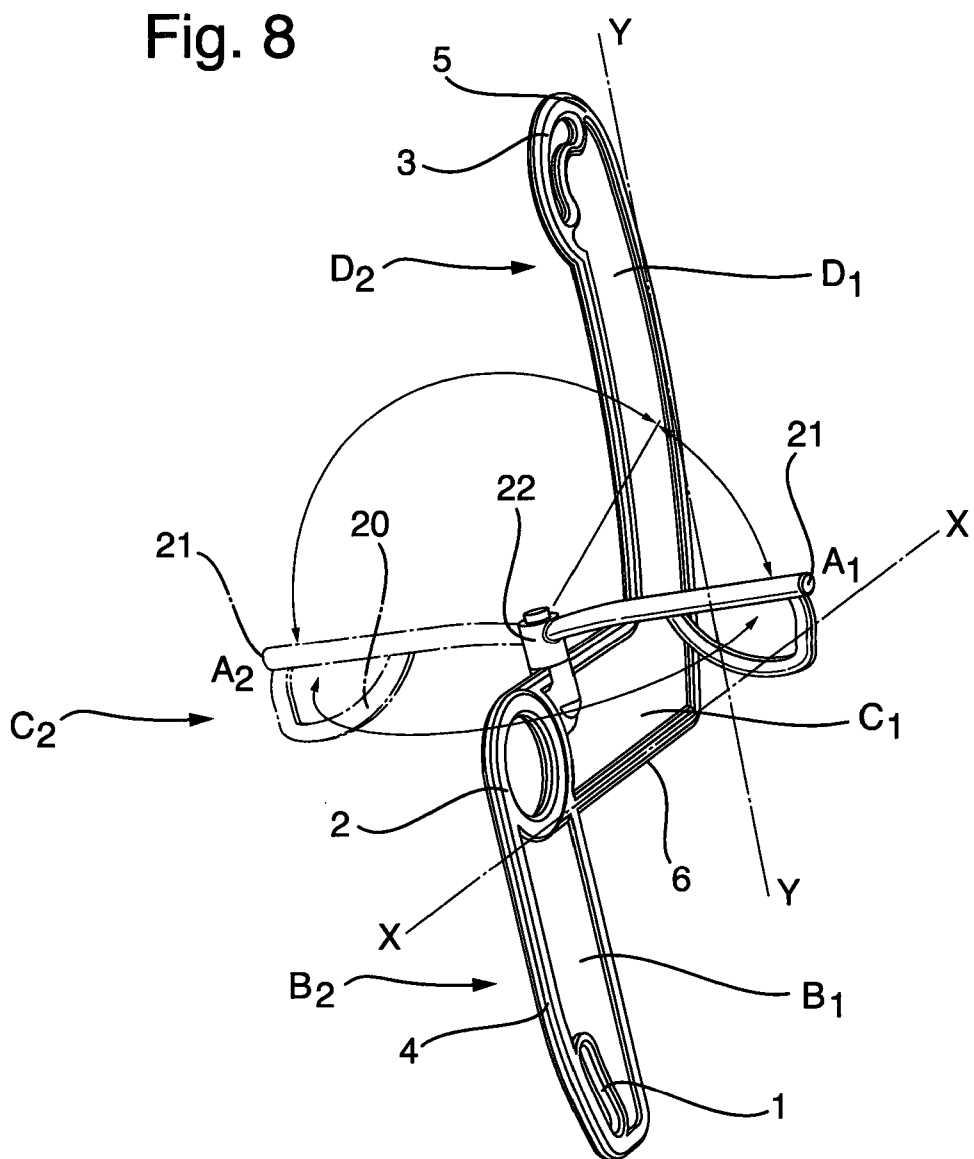
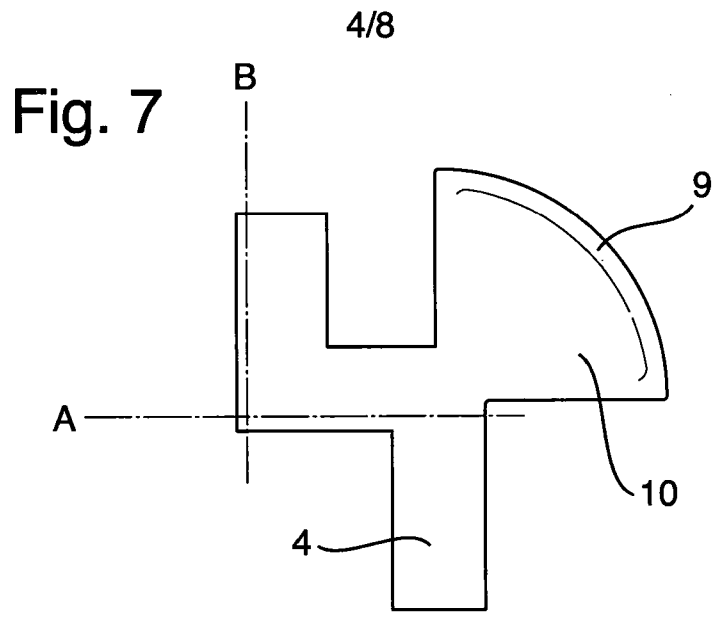

Fig. 9

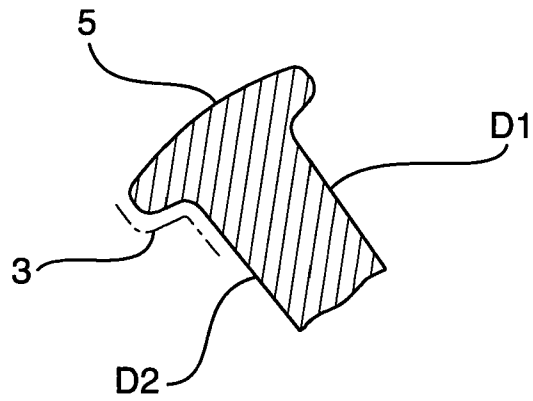

Fig. 10

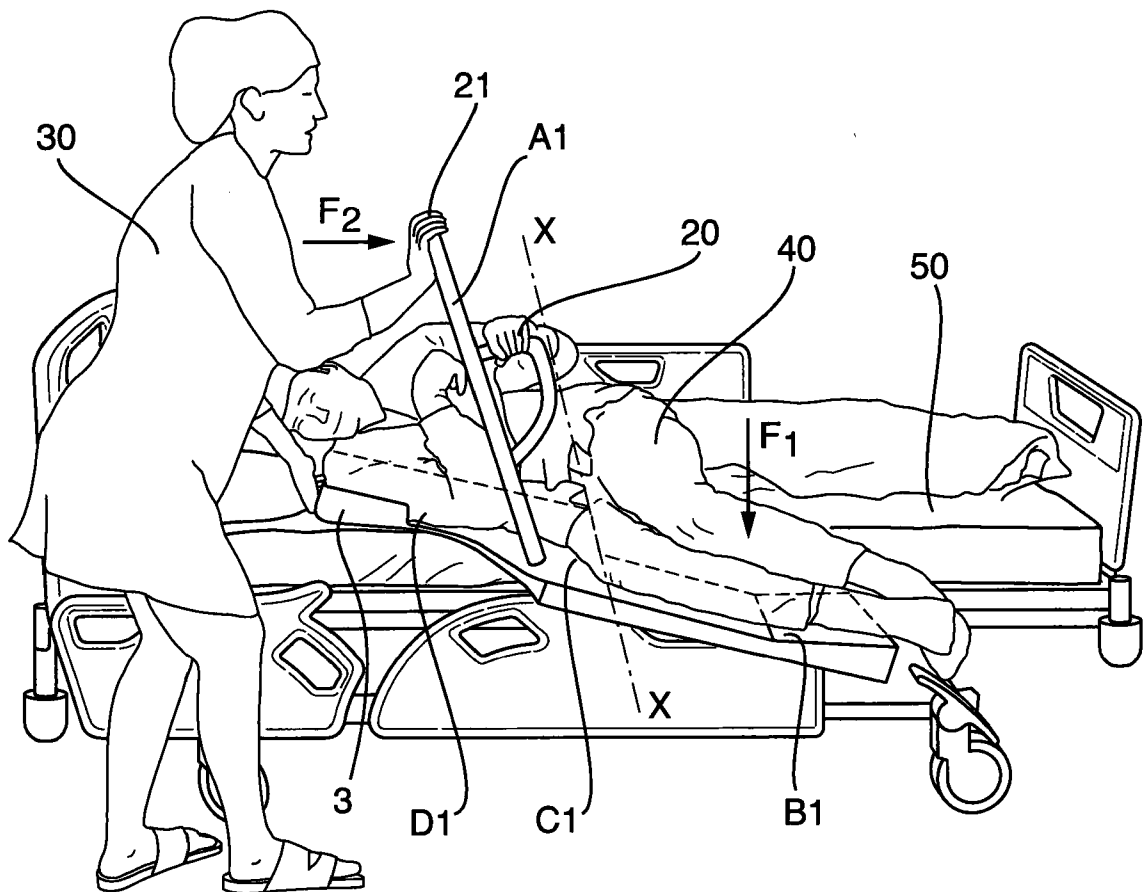

Fig. 11

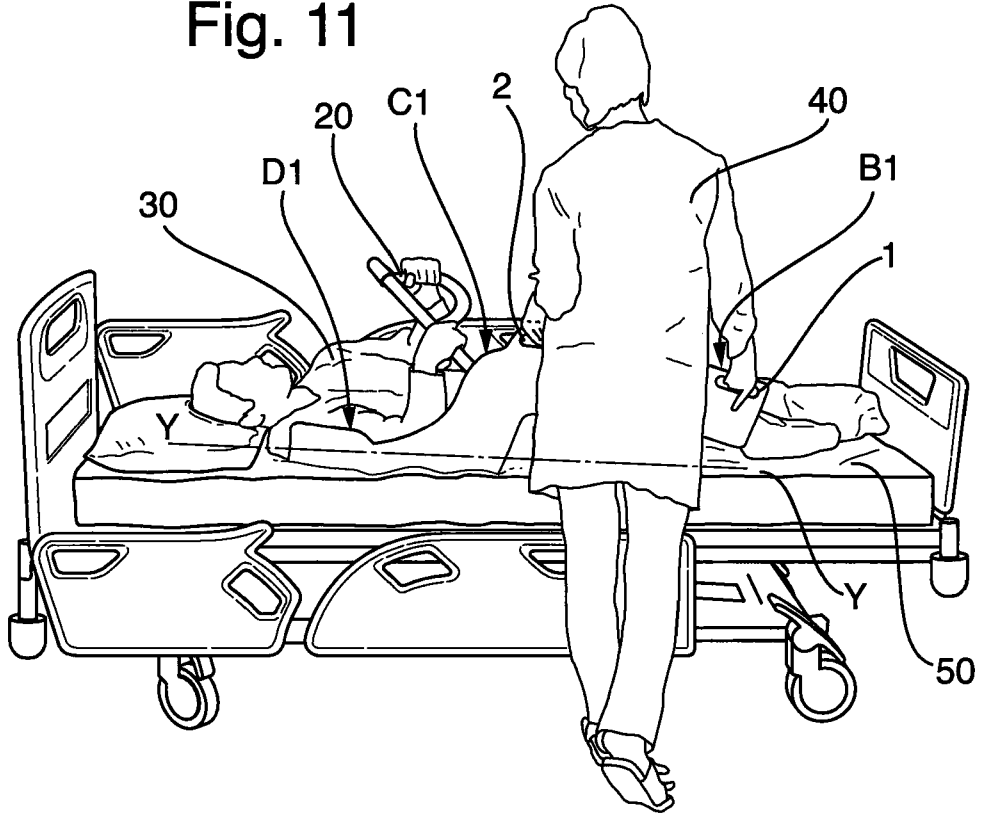

Fig. 12

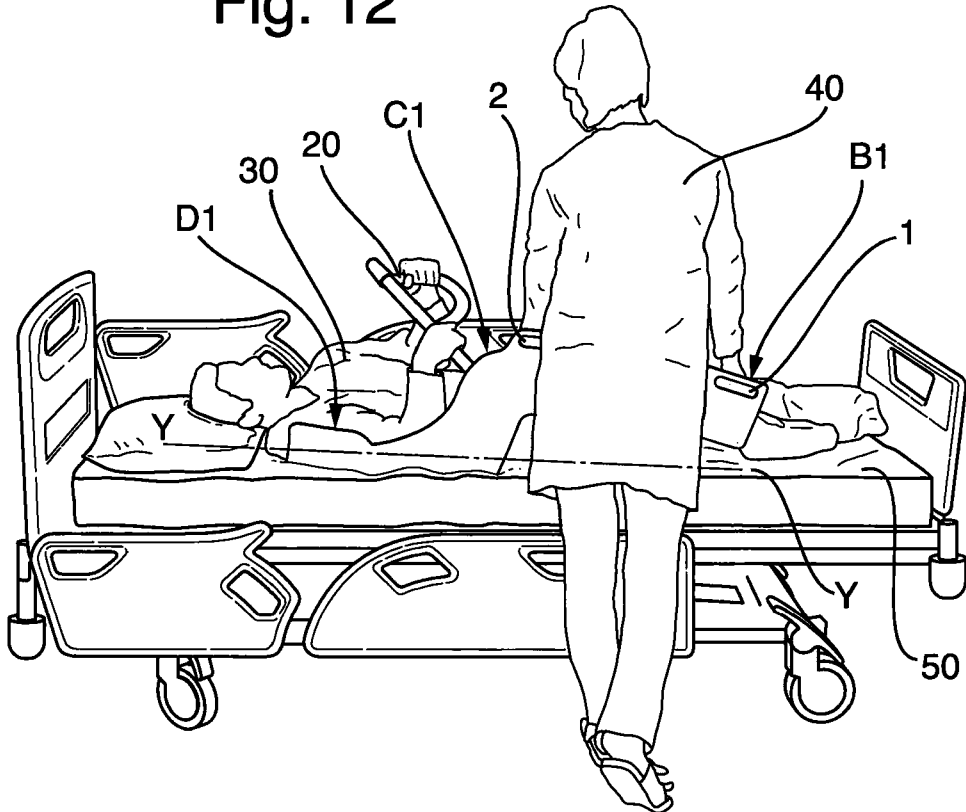

Fig. 13

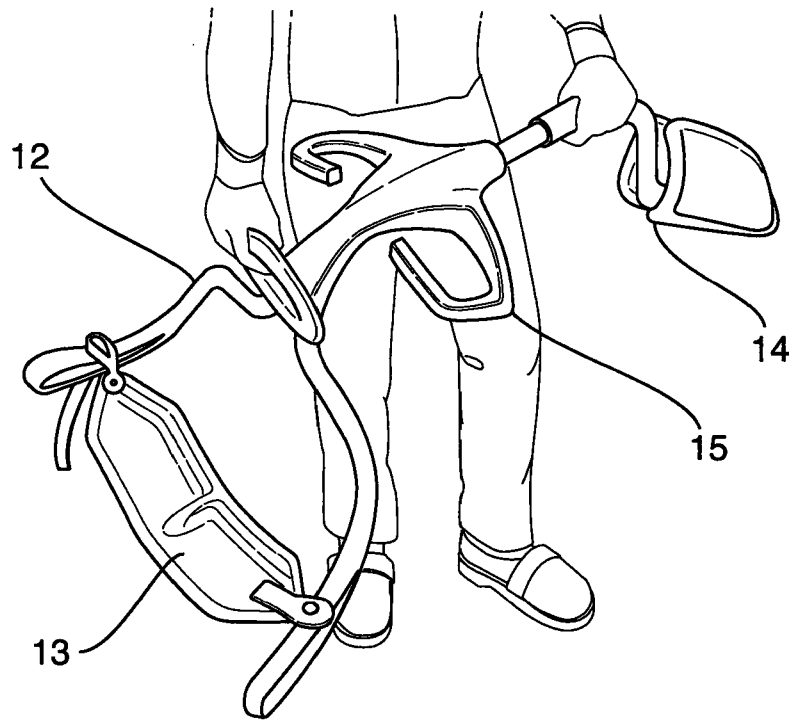

Fig. 14

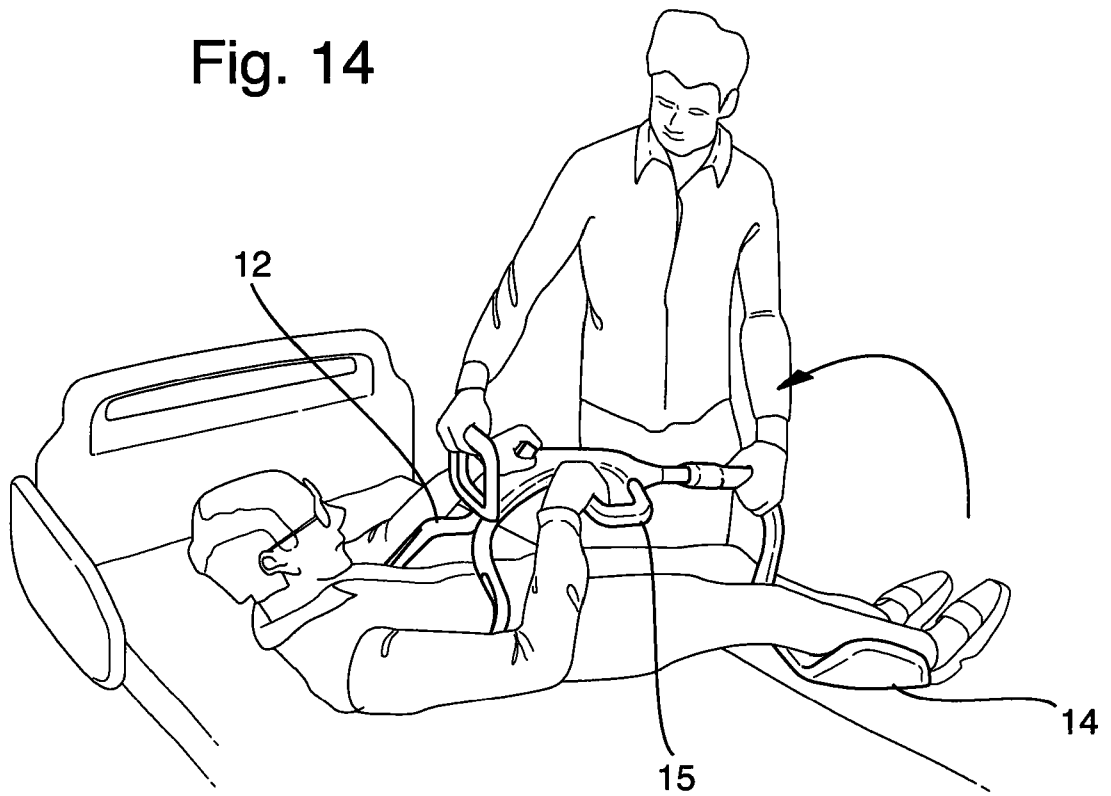
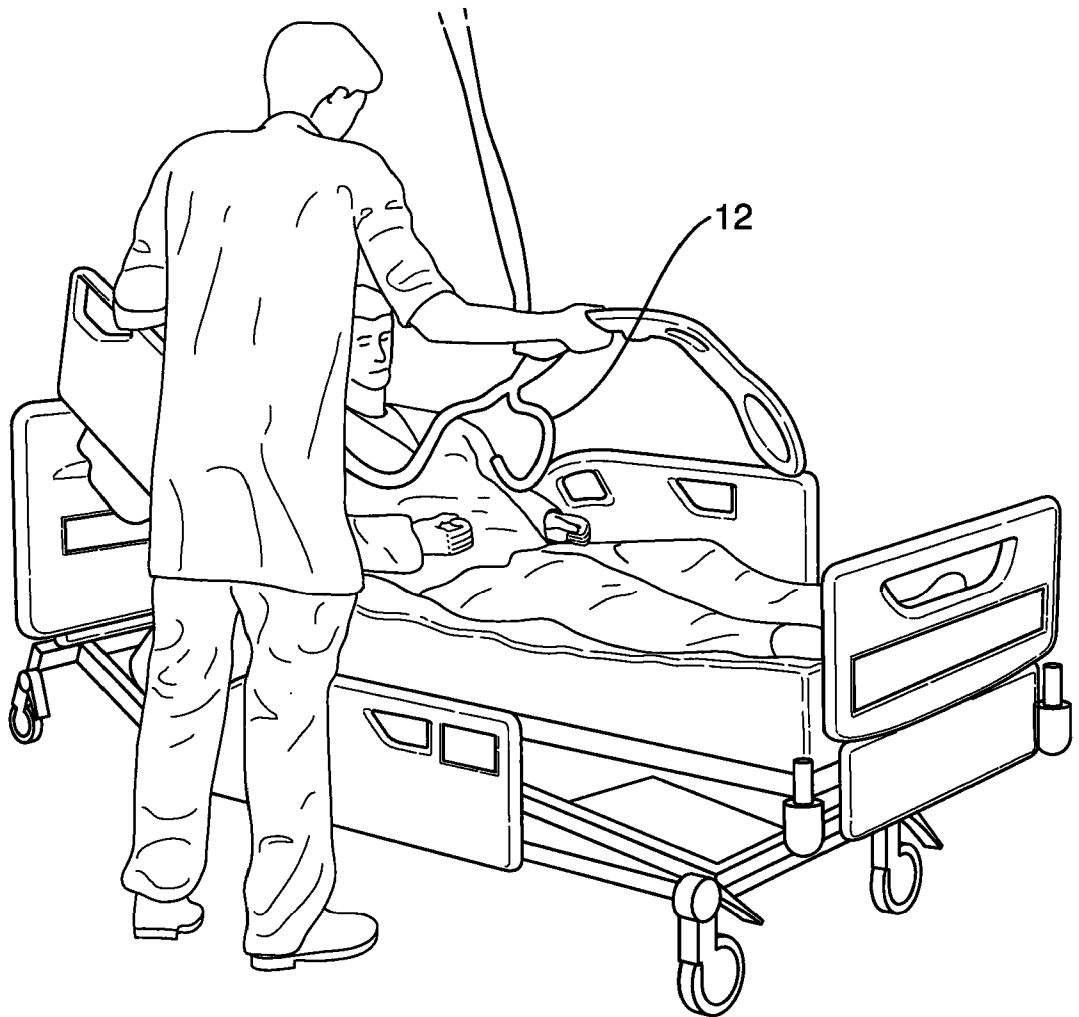

Fig. 15



# INTERNATIONAL SEARCH REPORT

International application No  
PCT/GB2013/052226

A. CLASSIFICATION OF SUBJECT MATTER  
INV. A61G7/053 A61G7/10  
ADD.

According to International Patent Classification (IPC) or to both national classification and IPC

**B. FIELDS SEARCHED**

Minimum documentation searched (classification system followed by classification symbols)  
A61G

Documentation searched other than minimum documentation to the extent that such documents are included in the fields searched

Electronic data base consulted during the international search (name of data base and, where practicable, search terms used)

EPO-Internal, WPI Data

**C. DOCUMENTS CONSIDERED TO BE RELEVANT**

Category*	Citation of document, with indication, where appropriate, of the relevant passages	Relevant to claim No.
X	US 5 916 085 A (WELLS JOHN R [US]) 29 June 1999 (1999-06-29) column 4, line 27 - column 7, line 37; figures 1-10	1-20
X	-----	
X	US 2004/019967 A1 (GANT DWANE C [US]) 5 February 2004 (2004-02-05) cited in the application paragraph [0039] - paragraph [0042] paragraph [0046] - paragraph [0048] figures 1-3, 9-11	1-20
X	-----	
X	US 6 938 285 B2 (FERNIE GEOFFREY ROY [CA] ET AL) 6 September 2005 (2005-09-06) column 4, line 24 - column 8, line 9; figures 4-6D	21-25
	-----	

Further documents are listed in the continuation of Box C.

See patent family annex.

\* Special categories of cited documents :

<p>"A" document defining the general state of the art which is not considered to be of particular relevance</p> <p>"E" earlier application or patent but published on or after the international filing date</p> <p>"L" document which may throw doubts on priority claim(s) or which is cited to establish the publication date of another citation or other special reason (as specified)</p> <p>"O" document referring to an oral disclosure, use, exhibition or other means</p> <p>"P" document published prior to the international filing date but later than the priority date claimed</p>	<p>"T" later document published after the international filing date or priority date and not in conflict with the application but cited to understand the principle or theory underlying the invention</p> <p>"X" document of particular relevance; the claimed invention cannot be considered novel or cannot be considered to involve an inventive step when the document is taken alone</p> <p>"Y" document of particular relevance; the claimed invention cannot be considered to involve an inventive step when the document is combined with one or more other such documents, such combination being obvious to a person skilled in the art</p> <p>"&amp;" document member of the same patent family</p>
---	---

Date of the actual completion of the international search	Date of mailing of the international search report
7 November 2013	14/11/2013

Name and mailing address of the ISA/ European Patent Office, P.B. 5818 Patentlaan 2 NL - 2280 HV Rijswijk Tel. (+31-70) 340-2040, Fax: (+31-70) 340-3016	Authorized officer  Sommer, Jean
--	--

# INTERNATIONAL SEARCH REPORT

Information on patent family members

International application No

PCT/GB2013/052226

Patent document cited in search report	Publication date	Patent family member(s)	Publication date
US 5916085	A	29-06-1999	NONE
-----			
US 2004019967	A1	05-02-2004	NONE
-----			
US 6938285	B2	06-09-2005	AU 7635400 A 15-04-2002
		GB 2384231 A	23-07-2003
		US 2004148699 A1	05-08-2004
		WO 0228340 A1	11-04-2002
-----			