

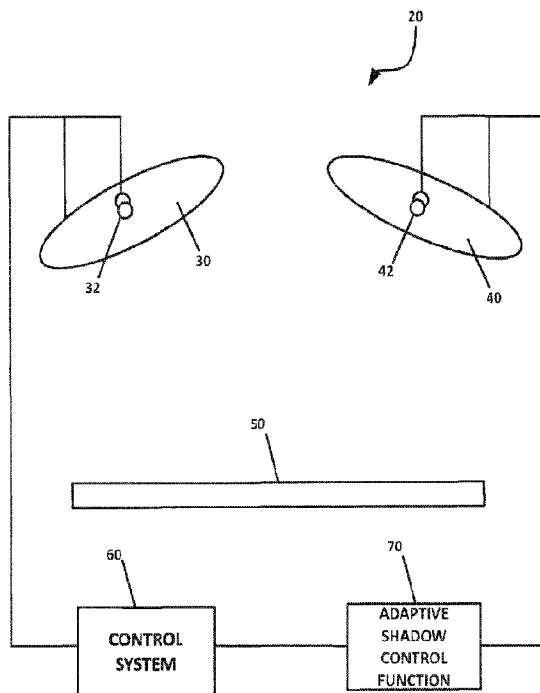

(86) Date de dépôt PCT/PCT Filing Date: 2017/07/26
 (87) Date publication PCT/PCT Publication Date: 2018/05/11
 (45) Date de délivrance/Issue Date: 2021/02/02
 (85) Entrée phase nationale/National Entry: 2019/04/12
 (86) N° demande PCT/PCT Application No.: US 2017/043880
 (87) N° publication PCT/PCT Publication No.: 2018/084905
 (30) Priorités/Priorities: 2016/11/01 (US62/415,595);
 2017/07/06 (US15/642,379)

(51) Cl.Int./Int.Cl. *A61G 13/00* (2006.01),
F21V 1/00 (2006.01), *G01B 9/08* (2006.01),
G01S 3/786 (2006.01), *G09G 3/32* (2016.01)
 (72) Inventeurs/Inventors:
 HOLLOPETER, MICHAEL, GB;
 JESURUN, DAVID, US
 (73) Propriétaire/Owner:
 AMERICAN STERILIZER COMPANY, US
 (74) Agent: MOFFAT & CO.

(54) Titre : SYSTEME DE COMMANDE D'OMBRE ADAPTATIVE POUR UN SYSTEME D'ECLAIRAGE CHIRURGICAL
 (54) Title: ADAPTIVE SHADOW CONTROL SYSTEM FOR A SURGICAL LIGHTING SYSTEM



(57) **Abrégé/Abstract:**

An adaptive shadow control system that compensates for blockage of one lighthouse of a surgical lighting system by increasing the light output from one or more other lighthoods of the lighting system. The system also includes control logic for automatic enablement/disablement of adaptive shadow control by detecting whether there is blockage of a lighthouse and whether the respective light beams of a plurality of lighthoods are being aggregated to form a single aggregated co-illumination light pattern at a work area.

Abstract

An adaptive shadow control system that compensates for blockage of one lighthouse of a surgical lighting system by increasing the light output from one or more other lighthouses of the lighting system. The system also includes control logic for automatic enablement/disablement of adaptive shadow control by detecting whether there is blockage of a lighthouse and whether the respective light beams of a plurality of lighthouses are being aggregated to form a single aggregated co-illumination light pattern at a work area.

ADAPTIVE SHADOW CONTROL SYSTEM FOR A SURGICAL LIGHTING SYSTEM

[0001]

Field of the Invention

[0002] The present invention relates generally to surgical lighting systems, and more particularly to an adaptive shadow control and co-illumination control for a surgical lighting system.

Background of the Invention

[0003] The present invention relates to the field of surgical lighting systems and problems associated therewith. In one aspect, shadow control is an important element of lighting system performance because it minimizes the contrast of shadow edges cast and minimizes reductions in illumination due to lighthouse blockage, thereby providing a uniform lighting field having consistent light intensity. A typical surgical lighting system includes at least one surgical lighthouse (also referred to as a “luminaire”), wherein each lighthouse is formed of a plurality of lighting modules. Typically, each lighting module is comprised of a plurality of LEDs (i.e., light emitting diodes).

[0004] Shadow control minimizes shadows (e.g., by diluting shadows) and/or minimizes the loss of illumination at a work area that results from a blockage between a lighthouse and the work area (e.g., a surgical site). Such blockage is commonly caused by the presence of a person’s head (e.g., a surgeon or surgical assistant) located between the lighthouse and the work area. Shadow control may be implemented using a passive or an adaptive (i.e., active/automatic) shadow control system.

[0005] Passive shadow control has been accomplished by increasing the effective area of the source lighting, such as by use of a large reflector, or by use of a plurality of separately-controlled lighting partitions spaced over a large area (i.e., multiple light sources).

[0006] Adaptive shadow control detects whether a lighthouse has been blocked by (i) directly sensing blockage of the lighthouse via proximity sensors or imaging techniques, or

(ii) indirectly sensing blockage, through a sensed loss of luminance (i.e., sensing reduced reflected light from the work area). In the direct sensing approach, the light output of the lighthouse's blocked light partitions is decreased (thereby reducing wasted light and minimizing irradiance on the surgeon's head), while the light output of the lighthouse's unblocked light modules is increased to compensate for the loss of illuminance due to the blockage. In the indirect sensing approach, the light output of the lighthouse is adjusted to maintain a desired luminance, regardless of whether changes to the lighting conditions are due to a blockage or a change in the surgical albedo (i.e., the proportion of incident light that is reflected by a surface at the work area).

[0007] In prior art surgical lighting systems, shadow control is limited to adjusting the light intensity of the lighting partitions in a single lighthouse due to a blockage incurred with respect to that same lighthouse. Accordingly, excess lighting capability is limited to the lighting partitions of the unblocked regions of a single lighthouse.

[0008] Reference is now made to INTERNATIONAL STANDARD IEC 60601-2-41 of the International Electrotechnical Commission (Medical electrical equipment – Part 2-41: Particular requirements for the safety of surgical luminaires and luminaires for diagnosis). This international standard requires testing for illuminance that remains after a light beam from a lighthouse 10 is obstructed by one mask 12 (FIG. 1A) or two masks 12a, 12b (FIG. 1B) that emulate a surgeon's head located between the lighthouse 10 and the work area. Since nearly 50% of the light emitting area is blocked in the one mask and two mask scenarios, compensation for lost illuminance requires 100% "excess" lumen output (i.e., double light output capacity).

[0009] Furthermore, adjustment of light output is limited to the number of unique lighting partitions within the lighthouse, wherein the light intensity of each lighting partition is independently controlled. A lighting system may have a lighthouse with one (1) proximity sensor associated with each lighting partition to determine whether there is a blockage between the lighthouse and the work area. As shown in FIG. 2A, a lighthouse 10 can have six (6) partitions 14 with a respective number of sensors 16. Each partition has a plurality of associated LEDs. When one or more masks 12 span multiple lighting partitions 14 of the lighthouse 10 (see FIGS. 2B and 2C), blocked sensors 16a correspond to the blocked lighting partitions of the lighthouse 10. The light output from the unblocked sensors 16b corresponding to the unblocked partitions 14b is increased to compensate for the blockage.

The blockage problem can be mitigated by increasing the number of unique lighting partitions of the lighthead. However, such an increase in the number of partitions results in a significant increase in engineering complexity, electrical inefficiency, lighthead size, and manufacturing cost.

[0010] In another aspect of the present invention, about 90% of surgical lighting installations in operating theaters include two lightheads. A small number (about 5-10%) of installations have three or more lightheads. Multiple lightheads are used in conjunction during an operation to provide supplemental lighting by focusing both beams to a single spot. This is known as "co-illumination" or "aggregation" and is intended to minimize shadowing effects on the work area by providing greater angular source distribution and to increase the amount of visible light.

[0011] The present invention provides a new and improved shadow control system and co-illumination detection system.

Summary of the Invention

[0012] In accordance with the present invention, there is provided an adaptive shadow control system for a surgical lighting system.

[0013] In accordance with another aspect of the present invention, there is provided an adaptive shadow control system that includes enable/disable control logic.

[0014] In accordance with yet another aspect of the present invention, there is provided a control system for detecting co-illumination in a surgical lighting system in order to activate and/or deactivate an adaptive shadow control system.

[0015] In accordance with still another aspect of the present invention, there is provided a control system for a surgical lighting system in which non-partitioned lightheads can be implemented, reducing cost and complexity of the surgical lighting system.

[0016] In accordance with still another aspect of the present invention, there is provided a surgical lighting system comprising: a first lighthead for illuminating a work area, said first lighthead formed as a unitary lighthead assembly; a first sensor assembly associated with the first lighthead for detecting blockage of light between the first lighthead and the work area; a second lighthead for illuminating the work area, said second lighthead formed as a unitary lighthead assembly; and an adaptive shadow control for receiving a blockage detection signal from the first sensor assembly and increasing the light output from

the unitary lighthouse assembly of at least one of the lighthoods to compensate for the blockage.

[0017] In accordance with still another aspect of the present invention, there is provided a surgical lighting system comprising: a plurality of lighthoods for illuminating a work area, each of said lighthoods having respective lighting modules that are pulsed between ON and OFF states, wherein the respective lighting modules of each lighthouse are pulsed out of phase; a first sensor assembly associated with one of the lighthoods to detect asynchronous ON and OFF pulsations from the lighting modules; a control system for determining whether the signals detected by the sensor assembly are within a threshold light level indicative of a co-illumination lighting mode resulting from an aggregated light pattern of overlapping light beams from a plurality of lighthoods; and an adaptive shadow control function of the control system for adjusting light output produced by at least one of the lighthoods, wherein said adaptive shadow control function is activated in response to the detected co-illumination lighting mode.

[0018] In accordance with still another aspect of the present invention, there is provided a process for controlling a surgical lighting system including a plurality of lighthoods, the process comprising: detecting blockage of at least one of the plurality of lighthoods between the lighthouse and a work area; detecting a co-illumination lighting mode resulting from overlapping light beams from more than one of the plurality of lighthoods into a single light pattern at a work area; and in response to detecting both the blockage and the co-illumination lighting mode, activating an adaptive shadow control for varying light output from at least one of the lighthoods to the work area.

[0019] An advantage of the present invention is the provision of an adaptive shadow control system that compensates for blockage of a first lighthouse using increased light output from a second lighthouse.

[0020] Another advantage of the present invention is the provision of an adaptive shadow control system that provides improved shadow control.

[0021] Still another advantage of the present invention is the provision of an adaptive shadow control system that uses a full lighthouse to compensate for loss of illumination due to blockage of another lighthouse in the lighting system.

[0022] Still another advantage of the present invention is the provision of an adaptive shadow control system that allows lighthoods to be configured with less excess

light output capacity and to have less complexity (e.g., eliminating the need for individual control of lighting partitions within a single lighthouse).

[0023] Yet another advantage of the present invention is the provision of an adaptive shadow control system that can be automatically enabled when it is detected that multiple lighthouses are used in conjunction with each other in a “co-illumination” mode to aggregate respective light beams, thereby forming a single light pattern at a work area.

[0024] Yet another advantage of the present invention is the provision of an adaptive shadow control system that includes enable/disable control logic which uses asynchronous operation of each lighthouse of a lighting system to determine whether the respective light beams of multiple lighthouses are being aggregated for co-illumination at a single location in a work area.

[0025] A still further advantage of the present invention is the provision of an adaptive shadow control system that reduces surgical staff workloads and distractions caused by lighting adjustment, light intensity maintenance, and repositioning of lighthouses.

[0026] These and other advantages will become apparent from the following description of illustrated embodiments taken together with the accompanying drawings and the appended claims.

Brief Description of the Drawings

[0027] The invention may take physical form in certain parts and arrangement of parts, an embodiment of which will be described in detail in the specification and illustrated in the accompanying drawings which form a part hereof, and wherein:

[0028] FIG. 1A shows a single mask projected onto a lighthouse;

[0029] FIG. 1B shows dual masks projected onto a lighthouse;

[0030] FIG. 2A shows a lighthouse having five (5) lighting partitions;

[0031] FIG. 2B shows a single mask projected onto a lighthouse having five (5) lighting partitions;

[0032] FIG. 2C shows a dual mask projected onto a lighthouse having five (5) lighting partitions;

[0033] FIG. 3 depicts an exemplary control system used in conjunction with a pair of surgical lighthouses;

[0034] FIG. 4A shows a single lighthouse having five (5) sensor assemblies;

[0035] FIG. 4B shows a single mask projected onto a single lighthouse having five (5) sensor assemblies;

[0036] FIG. 4C shows a dual mask projected onto a lighthouse having five (5) lighting sensor assemblies;

[0037] FIG. 5 shows a system having a pair of lighthouses operating in a co-illumination lighting mode that produces overlapping, aggregated light patterns at a work area;

[0038] FIG. 6 shows a system having a pair of lighthouses operating in an independent lighting mode that produces a pair of independent light patterns at different work areas;

[0039] FIG. 7 illustrates the signals for detecting whether a lighthouse is operating in a co-illumination or independent lighting mode, according to an embodiment of the present invention; and

[0040] FIG. 8 illustrates control logic for enabling/disabling adaptive shadow control, according to an embodiment of the present invention.

Detailed Description of the Invention

[0041] Referring now to the drawings wherein the showings are for the purposes of illustrating an embodiment of the invention only and not for the purposes of limiting same, the present invention is directed to an adaptive shadow control system for a surgical lighting system. As shown in FIG. 3, a lighting system 20 is comprised of two lighthouses 30, 40 where each lighthouse 30, 40 includes at least one lighting module having one or more light elements, which can be LEDs. The lighthouses 30, 40 illuminate a work area (e.g., a surgical site of a surgical patient supported by a surgical table 50). In accordance with an embodiment of the present invention, sensor assemblies 32, 42, are associated with each respective lighthouse 30, 40 (e.g., mounted to the lighthouse housing) to detect whether there is a blockage, between the lighthouse and the work area, that is blocking at least a portion of the associated light beam emitted by one or both of the lighthouses 30, 40. The sensor assemblies 32, 42 may detect blockage of light beams directly or indirectly. For example, the sensor assemblies 32, 42, may take the form of a proximity sensor or an image sensor to directly sense a blockage. Alternatively, the sensor assemblies 32, 42, may take the form of a light sensor that senses a loss of luminance to indirectly sense a blockage. It should be

appreciated that the sensor assemblies 32, 42, may be alternatively located proximate to the work area rather than mounted to the respective lightheads 30, 40. Furthermore, it is contemplated that multiple sensors can be used in combination.

[0042] The lighting system 20 of FIG. 3 also includes a control system 60 that receives signals from the sensor assemblies 32, 42 and controls the light output from the lightheads 30, 40 using an adaptive shadow control function 70. For the purpose of illustrating an embodiment of the present invention, a lighting system with two (2) lightheads 30, 40 will be described herein. However, it should be understood that this is not intended to limit the scope of the present invention, since it is contemplated that the present invention may be implemented in connection with lighting systems that include more than two lightheads.

[0043] An exemplary lighthead 30 is shown in FIG. 4A. As depicted, the lighthead 30 includes a single lighting unit formed as a unitary lighthead assembly without individual lighting partitions, with a single control governing the operation of the entire lighthead. The lighthead 30 as shown includes six (6) sensor assemblies 32, arranged in a substantially pentagonal configuration. However, it is to be appreciated and understood that any desirable number of sensor assemblies 32 in any desirable configuration can be implemented without departing from the inventive concept disclosed herein. As shown in FIGS. 4B and 4C, these sensor assemblies 32 can detect the position of the blockage of the lighthead 30. If more than one sensor assembly 32a is blocked by one or more obstructions 36 (e.g., a surgeon's head), the system can estimate the degree of blockage of the lighthead 30. In a special aspect of the present invention, the lighthead 30 is a single assembly formed of respective lighting modules, and is not divided into lighting partitions as with previous-type lightheads.

[0044] If a blockage of a light beam associated with the first lighthead 30 is detected by the sensor assembly 32, then the control system 60 implements the adaptive shadow control function 70 of the present invention by compensating for this blockage with increased light output from the second lighthead 40. Conversely, if a blockage of a light beam associated with the second lighthead 40 is detected by the sensor assembly 42, then the control system 60 implements the adaptive shadow control function 70 of the present invention to compensate for this blockage with increased light output from the first lighthead 30.

[0045] By compensating for a loss of luminance at the surgical site from a blocked lighthead through increased light output from an unblocked lighthead, the excess lighting capacity required for total compensation is reduced to 50% per lighthead. Since individual lightheads can be freely positioned, it is assumed that one lighthead may be positioned such that it incurs little or no blockage.

[0046] The adaptive shadow control function 70 is automatically enabled or disabled based on a detection of a mode of operation for the lightheads 30, 40. In a first mode of operation (i.e., a co-illumination lighting mode), the respective light beams produced by the two lightheads 30, 40 are positioned by a user to focus on a single work area at a single location, thereby producing an aggregated co-illumination light pattern 52 in which the light beams from each lighthead 30, 40 overlap (see FIG. 5). In the co-illumination lighting mode, the control system 60 enables the adaptive shadow control function 70. The control system 60 independently adjusts the light output produced by the two lightheads 30, 40 in order to dilute shadows in a desired operating area of the surgical patient in the surgical work area.

[0047] In a second mode of operation (i.e., an independent lighting mode), the two lightheads 30, 40 are operated independently, such that the light beams emitted by the two lightheads 30, 40 are not overlapped (or “co-illuminating”) at a single work area at a single location, thereby producing two (2) independent light patterns 54, 56 (see FIG. 6) at different work areas having respective different locations. If the control system 60 determines that the lighting system 20 is operating in an independent lighting mode, then the control system 60 disables the adaptive shadow control function 70 of the present invention.

[0048] In accordance with one embodiment of the present invention, the control system 60 automatically determines whether the lightheads 30, 40 are operating in (i) a co-illumination lighting mode or (ii) an independent lighting mode, by operating the lightheads 30, 40 asynchronously. In this regard, the lighting modules (i.e., LEDs) of the first and second lightheads 30, 40 are asynchronously pulsed ON and OFF such that the LEDs of the first lighthead 30 have an OFF period while LEDs of the second lighthead 40 have an ON period concomitantly (see waveforms A and B of FIG. 7). The lighting modules in each lighthead 30, 40 are pulsed very rapidly, so that the light pulsates at a frequency faster than can be visually detected by the human eye (which cannot observe pulsations faster than a frequency of 30 Hz). The selected pulse frequency should be too high for human eye

detection, but at a frequency where the light pulses are detectable by a sensor. The light of both lightheads 30, 40 are pulsed 180 degrees out of phase with each other, giving the human eye the perception that the co-illumination is continuous and at constant intensity. This perceived continuous illumination intensity is represented by the illumination of both lightheads 30, 40 in the ON state averaged out over the span of a duty cycle.

[0049] It should be appreciated that while an embodiment of the present invention is described with pulsation of the lightheads 180 degrees out of phase with each other, the degrees of phase shift may be changed to accommodate a lighting system with more than two (2) lightheads.

[0050] The sensor assembly 32 of the first lighthead 30 includes a light sensor (e.g., photodiodes or phototransistors mounted to the lighthead housing) that senses the amount of incident light during the OFF period for the first lighthead 30 (see waveforms C and D of FIG. 7). The light sensor detects the total light reflecting from the illuminated area and generates signals corresponding to the detected illumination level. These signals are transmitted to the control system 60, which uses the signals to control the operation of the lightheads 30, 40.

[0051] If the amount of incident light sensed by the light sensor during the OFF period of the first lighthead exceeds a predetermined threshold light level (indicated by the dashed line in waveform C), then the control system 60 determines that the first and second lightheads 30, 40 are operating in a co-illumination lighting mode (i.e., pointing their respective light beams at a single work area at a single location to form an aggregated co-illumination light pattern). In this instance, the control system 60 activates the adaptive shadow control function 70. Conversely, if the amount of incident light sensed by the light sensor during the OFF period of the first lighthead 30 does not exceed a predetermined threshold light level (indicated by the dashed line in waveform D), then the control system 60 determines that the first and second lightheads 30, 40 are operating in the independent lighting mode (i.e., pointing their respective light beams at two different work areas in respectively different locations).

[0052] As depicted in FIG. 7, in order to detect the operating mode of the lightheads 30, 40, the control system 60 operates the lightheads 30, 40 asynchronously, 180 degrees out of phase with other, with the pulsed LEDs within the light modules of the first lighthead 30 having an OFF period at the same time that the light modules of second lighthead 40 have an

ON period concomitantly. While the first lighthouse 30 is in the OFF state, the sensor assembly 32 “watches” to detect the amount of light incident on the illuminated area. If the amount of detected incident light is determined to exceed the indicated threshold, it can be inferred that the two lighthouses 30, 40 are pointing to a single spot, indicating a co-illumination operating mode. Essentially, the threshold (shown in waveforms C and D) indicates whether the sensor assembly 32 of the first lighthouse 30 detects whether the light from the second lighthouse 40 is shining in the same location, and thereby indicating co-illumination.

[0053] Determining whether lighthouses are operated together in a co-illumination mode (i.e. pointed to a single spot) or operated separately in an independent mode can be accomplished automatically by employing a suitable technique. The adaptive shadow control function 70 of the control system 60 can preferably be operated on the following basis: 1) two lights are co-illuminating a single work area, and is detected and determined by the lighthouses; 2) blockage of a lighthouse is sensed; and 3) the loss of illumination is compensated by the secondary, or complementary, lighthouse when both above conditions are met.

[0054] It should be noted that the first and second sensor assemblies 32, 42 can include both types of sensor elements described hereinabove to be used for determining both blockage and co-illumination. In one aspect, the sensor assemblies 32, 42 of one of the respective lighthouses 30, 40 can be used to detect blockage while the sensor assemblies 32, 42 of the respective other of the lighthouses 30, 40 can be used to detect co-illumination. Alternatively, in a multi-sensor configuration such as the pentagonal arrangement shown in the exemplary lighthouse 30 of FIGS. 4A, 4B, and 4C, the blocked sensor assemblies 32a can be used to detect blockage while the unblocked sensor assemblies 32 of the same lighthouse 30 can be used to detect co-illumination. Any combination of sensors from either of the sensor assemblies 32, 42 from either lighthouse 30, 40 can be used to make the necessary determinations, all without departing from the invention.

[0055] The control system 60 preferably employs an automatic shadow control enabling algorithm that detects the blockage on a lighthouse. The control system 60 also preferably employs detecting whether the light beams from each lighthouse 30, 40 are aggregated into a single overlapping light pattern of aggregated, co-illuminated light. Such an algorithm 80 for “enabling” and “disabling” adaptive shadow control will now be

described in connection with FIG. 8. In accordance with one embodiment of this algorithm, the respective sensor assemblies 32, 42 of each lighthouse 30, 40 are used to detect whether there is a lighthouse blockage or whether the lighthouses 30, 40 are operating in the co-illumination lighting mode. If both a lighthouse blockage and a co-illumination lighting mode are detected, then the adaptive shadow control function 70 is enabled. In contrast, if either the lighthouse blockage or the co-illumination lighting mode is not detected, then the adaptive shadow control function 70 is disabled.

[0056] The algorithm 80 as disclosed herein and depicted in FIG. 8 can be expressed in terms of Boolean logic gates (e.g., AND gates and OR gates) wherein system inputs and outputs are processed according to Boolean operations. Of course, it is to be understood that such an expression is not limiting and that other operational logic schemes can be employed without departing from the invention.

[0057] As specifically shown in the algorithm 80 of FIG. 8, either a first lighthouse blockage 82 or a second lighthouse blockage 84 can be detected by the sensor assemblies 32, 42 of the respective lighthouses 30, 40. These blockage detections 82, 84 are received as “high” inputs and passed through an OR gate 86, such that if blockages 82, 84 are detected at either lighthouse 30, 40, the OR gate 86 indicates a “high” output. If no blockage is detected at either lighthouse 30, 40, the OR gate 86 indicates a “low” output.

[0058] As also shown in FIG. 8, a first lighthouse co-illumination state 90 and a second lighthouse co-illumination state 92 can be detected by the sensor assemblies 32, 42 of the respective lighthouses 30, 40. These co-illumination detections 90, 92 along with an auto-enable command 94 are received as “high” inputs and passed through a first AND gate 96. If co-illumination states 90, 92 from both lighthouses 30, 40 and also the auto-enable command 94 are received, the output of the first AND gate 96 is “high,” and activates the adaptive shadow control function 70 of the control system 60. But if co-illumination states 90, 92 from either or both of the lighthouses 30, 40 and also the auto-enable command 94 are not received, the output of the first AND gate 96 is “low,” and a negative activation state is indicated (e.g., deactivation) of the adaptive shadow control function 70 of the control system 60. In other words, unless co-illumination states 90, 92 from both lighthouses 30, 40 are indicated, additionally in combination with the auto-enable command 94, the adaptive shadow control 70 is not activated.

[0059] The outputs of the OR gate 86 and the adaptive shadow control function 70 are received as inputs at a second AND gate 100. If both of the inputs are “high,” indicating blockage 82, 84 at least one of the lightheads 30, 40 and activation of the adaptive shadow control function 70, the output of the second AND gate 100 is “high.” If one or both of the inputs are “low,” indicating either no blockage at one or both lightheads 30, 40 or deactivation of the adaptive shadow control function 70, the output of the second AND gate 100 is “low.” The output of the second AND gate 100 is processed at a decision block 102. A “high” output from the second AND gate 100 renders a “yes” (Y) result at the decision block 102 and activates compensation 104 which sends an “enable shadow control” signal 106 to the adaptive shadow control function 70, thereby maintaining activation. A “low” output from the second AND gate 100 renders a “no” result at the decision block 102 and sends a “disable shadow control” signal 108 to the adaptive shadow control function 70, thereby ensuring deactivation.

[0060] A control law for the control system 60 has three inputs, beside the auto enable function at the system level: 1) lighthouseSensors, in which an integer number of sensors are used for detecting blockage in the lighthouse under operation; 2) complementaryLighthouseSensors, in which an integer number of sensors are used for detecting blockage from a second lighthouse; and 3) co-illuminate, in which a “high” Boolean logic output from the lightheads 30, 40 corresponds to a determination that there are two spots co-illuminating a single work area.

[0061] Complementary lighthouse compensation accuracy depends on the number of blockage detectors. With too few sensor assemblies 32 per lighthouse 30, a surgeon’s head partially blocking the lighthouse 30 may not be detected, and no compensation can be applied. The error associated with the compensation is driven by the resolution of blockage detection. FIGS. 4A, 4B, and 4C show an embodiment in which six sensor assemblies 32 are implemented for a single lighthouse 30 having a unitary assembly, without individual lighting modules, in a generally pentagonal arrangement around a central sensor assembly. A comparison follows of expected compensation and adaptive shadow control error for up to six sensor assemblies 32:

No. of Heads, Sensors	Compensation	Typical Error
Single lighthouse, no sensors	0%	-15%
Dual lighthouse, no sensors		
Single lighthouse, one sensor	23%	+10% - 15%
Dual lighthouse, one sensor		
Single lighthouse, two sensors	35%	+15% - 15%
Dual lighthouse, two sensors		
Single lighthouse, three sensors	45%	+15% - 15%
Dual lighthouse, three sensors		
More than three sensors	55%	+15% - 15%

[0062] In addition to the benefits of the present system in providing adaptive shadow control, the present co-illumination detection system can be used for processing any number of automatic responses, including regulation of energy or adaptive shadow control of one or both of the lighthoods 30, 40, changing intensity of one or both of the lighthoods 30, 40, changing spectral distribution of one or both of the lighthoods 30, 40, changing beam size of one or both of the lighthoods 30, 40, adjusting aim of one or both of the lighthoods 30, 40, or providing audible or visible indication that co-illumination has been detected, etc. Additionally, co-illumination detection can also be used to automatically regulate the maximum light intensity, to not exceed the limit of hazardous levels energy known to cause burning or dehydration of exposed tissue of the surgical patient. The limitation of the maximum light intensity is accomplished automatically by fading down at an imperceptible rate to the appropriate lighting condition. For example, if two surgical lighthoods 30, 40 each at 160,000 lx (160 klx) were brought together to co-illuminate the surgical wound, the control system 60 could detect the co-illumination and fade down to 100,000 lx each over a period of time. The additive light would result in 200,000 lx instead of the more hazardous level of 320,000 lx. Another implementation may be to govern each intensity setting by a scaling factor, rather than having a single maximum value.

[0063] Other approaches contemplated for determining whether multiple lighthoods 30, 40 are being used together to co-illuminate light beams at a single location (i.e., used in an aggregated co-illumination lighting mode), include, but are not limited to: asynchronous

lighthouse LED pulse operation (pulse-watch through photodiodes); positional encoders located in arms or joints of the suspension system supporting the lighthouses 30, 40 for determining the position and pointing direction of the lighthouses 30, 40; proximity detectors (e.g., Hall Effect, field strength, and ultrasonic) for sensing the locality of the edge of each of the lighthouse 30, 40; a secondary sensor and transmitter (infrared, for example); a triangulation network (similar to GPS) for determining lighthouse 3-D coordinates, and supplementing sensors in the lighthouses 30, 40 for determining lighthouse aim (such as inclinometers); and boresight aiming (laser scattering), which is similar to the asynchronous light operation, where lasers are deployed by each of the lighthouses 30, 40 that uniquely identifies each lighthouse (e.g., by color or asynchronous operation).

[0064] The present invention provides a novel active shadow control system implemented to use a full lighthouse without requiring individual lighting partitions to compensate for a blocked lighthouse. The present system also provides improved shadow control and intensity maintenance compared to a prior art passive lighting system due to the detection of blockage and individual adjustment of intensity between the plurality of lighthouses without requiring individual lighting partitions. The present system also provides improved workload and reduces distraction of surgical staff due to automatic adjustment. Repositioning of lighthouses by the surgical staff is also minimized.

[0065] The present invention also provides utilization of a full lighthouse without requiring a lighthouse having individual lighting partitions within the surgical lighting system to compensate for loss of illumination due to blockage. Full lighthouse compensation requires less excess capacity, and less complexity within a single lighthouse since individual control of lighting partitions is no longer required. By eliminating the necessity of individual lighting partitions, the present system reduces engineering complexity, electrical inefficiency, and lighthouse size associated with the system and thereby reduces the expense associated with manufacture and maintenance of the lighthouses.

[0066] The foregoing describes specific embodiments of the present invention. It should be appreciated that these embodiments are described for purposes of illustration only, and that numerous alterations and modifications may be practiced by those skilled in the art without departing from the spirit and scope of the invention. It is intended that all such modifications and alterations be included insofar as they come within the scope of the invention as claimed or the equivalents thereof.

Claims:

1. A surgical lighting system comprising:

a first lighthouse for emitting a light beam to illuminate a work area, said first lighthouse formed as a unitary lighthouse assembly, wherein said first lighthouse includes at least one lighting module having one or more light elements;

a second lighthouse for emitting a light beam to illuminate the work area, said second lighthouse formed as a unitary lighthouse assembly, wherein said second lighthouse includes at least one lighting module having one or more light elements;

a first sensor for detecting a blockage of the light beam emitted by the first lighthouse;

an adaptive shadow control for receiving a signal from the first sensor indicative of detecting the blockage of the light beam emitted by the first lighthouse and increasing light output from the second lighthouse to compensate for the blockage of the light beam emitted by the first lighthouse; and

a control system configured for detecting a signal indicative of (i) a co-illumination lighting mode resulting from overlapping of the light beams emitted from the first and second lighthouses to form a single aggregated light pattern on the work area, or (ii) an independent lighting mode resulting from independent operation of the first and second lighthouses such that the light beams emitted from the first and second lighthouses do not overlap to form a single aggregated light pattern on the work area.

2. The surgical lighting system according to claim 1, wherein the first sensor is a light sensor for sensing a loss of luminance to indirectly detect the blockage of the light beam emitted by the first lighthouse.

3. The surgical lighting system according to claim 1, wherein the first sensor is a proximity sensor or an image sensor to directly detect the blockage of the light beam emitted by the first lighthouse.

4. The surgical lighting system according to claim 1, wherein the surgical lighting system includes a plurality of sensors for detection of a blockage of the light beam emitted by the first lighthouse, wherein detection of the blockage of said light beam by more than one of the sensors corresponds to an estimated degree of blockage of the light beam emitted by the first lighthouse.
5. The surgical lighting system according to claim 1, wherein the control system is configured to disable operation of the adaptive shadow control upon detecting the signal indicative of the independent lighting mode.
6. The surgical lighting system according to claim 1, wherein the surgical lighting system includes a light sensor for sensing a level of reflected light from the work area, said light sensor generating a signal corresponding to a sensed illumination level.
7. The surgical lighting system according to claim 1, further comprising a second sensor associated with the second lighthouse for detecting a blockage of the light beam emitted by the second lighthouse to illuminate the work area, wherein the adaptive shadow control receives a signal from the second sensor indicative of detecting the blockage of the light beam emitted by the second lighthouse and increases light output from the first lighthouse to compensate for the blockage of the light beam emitted by the second lighthouse.
8. A surgical lighting system comprising:
 - a plurality of lighthouses for respectively emitting a light beam to illuminate a work area, each of said lighthouses having respective lighting modules that are asynchronously pulsed between ON and OFF states, wherein the respective lighting modules of each lighthouse are asynchronously pulsed such that lighting modules of only one of the lighthouses are ON while the lighting modules of the other lighthouses are OFF;
 - a first sensor for detecting the asynchronous pulsations of the ON and OFF states of the lighting modules;
 - a control system configured for detecting a signal indicative of (i) a co-illumination lighting mode resulting from overlapping of the light beams emitted from the plurality of lighthouses to form a single aggregated light pattern on the work area, or (ii) an independent

lighting mode resulting from independent operation of the plurality of lighthoods such that the light beams emitted from the plurality of lighthoods do not overlap to form a single aggregated light pattern on the work area; and

an adaptive shadow control function for adjusting light output from at least one of the plurality of lighthoods in response to blockage of at least one of the light beams, wherein said control system enables the adaptive shadow control function in response to detection of the co-illumination lighting mode and disables the adaptive shadow control function in response to detection of the independent lighting mode.

9. The surgical lighting system according to claim 8, wherein the lighting modules of the plurality of lighthoods are asynchronously pulsed between the ON and OFF states at a predetermined pulsation frequency that cannot be visually detected.

10. The surgical lighting system according to claim 9, further comprising a second sensor for detecting a blockage of one of the light beams emitted by one of the plurality of lighthoods, wherein the adaptive shadow control function varies operation of at least one of the lighthoods such that the light output produced by at least one of the plurality of lighthoods is increased in response to the blockage detected by the second sensor.

11. A process for controlling a surgical lighting system including a plurality of lighthoods, the process comprising:

detecting a signal indicative of whether there is a blockage of a light beam emitted by at least one of the plurality of lighthoods to illuminate a work area;

detecting a signal from a sensor that indicates (i) a co-illumination lighting mode resulting from overlapping of the light beams emitted from a plurality of lighthoods to form a single aggregated light pattern on the work area, or (ii) an independent lighting mode resulting from independent operation of the plurality of lighthoods such that the light beams emitted from the plurality lighthoods do not overlap to form a single aggregated light pattern on the work area; and

enabling operation of an adaptive shadow control when the co-illumination lighting mode is detected and disabling the adaptive shadow control when the independent lighting mode is

detected, said adaptive shadow control varying light output from at least one of the plurality of lighthoods in response to detecting said blockage.

12. The process according to claim 11, further comprising said adaptive shadow control increasing the light output from at least one of the plurality of lighthoods to provide additional illumination to the work area in response to detecting said blockage.

13. The process according to claim 11, wherein the process includes asynchronously pulsing the plurality of lighthoods between an ON state and an OFF state

14. The process according to claim 11, wherein each of the plurality of lighthoods is pulsed out of phase between an ON state and an OFF state.

1/9

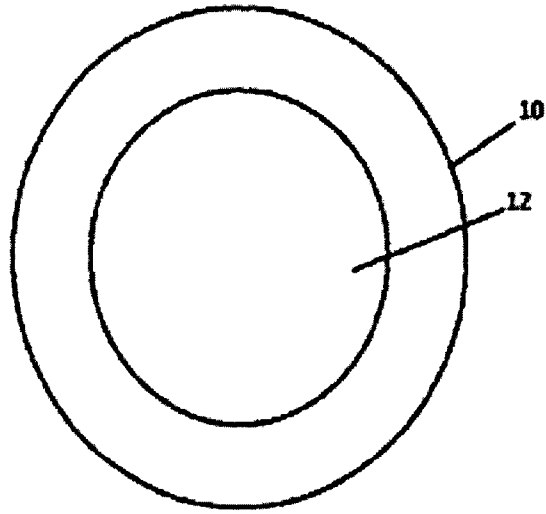

FIG. 1A
PRIOR ART

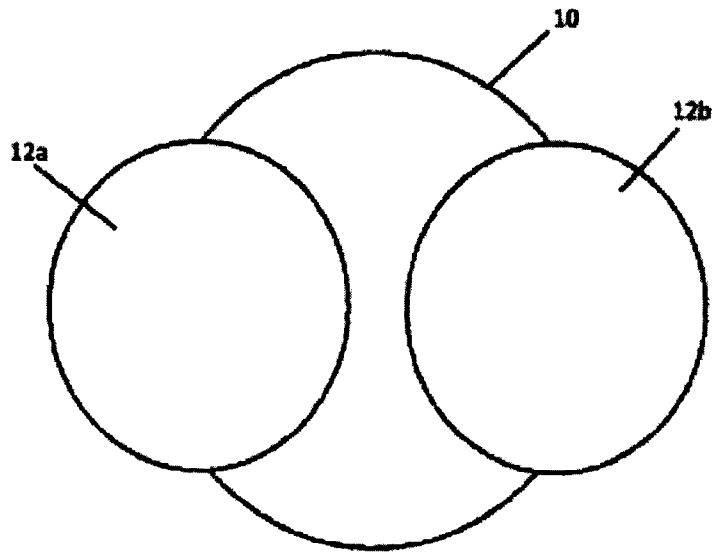

FIG. 1B
PRIOR ART

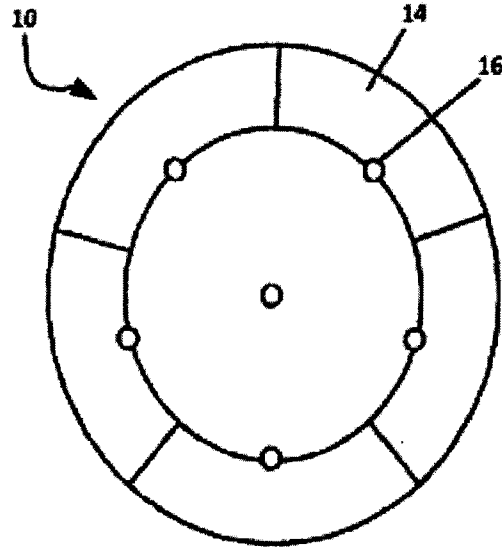

FIG. 2A
PRIOR ART

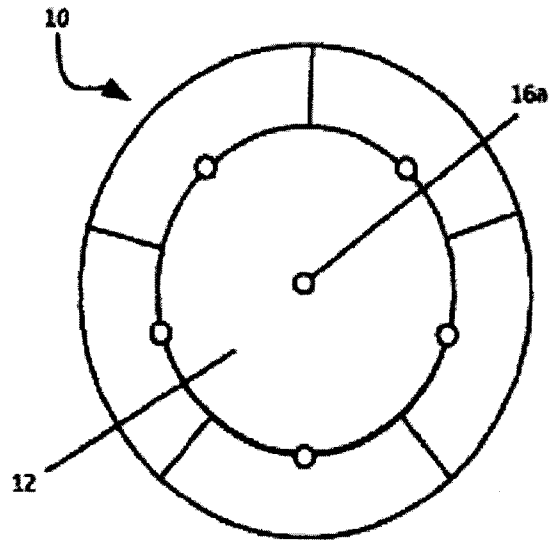

FIG. 2B
PRIOR ART

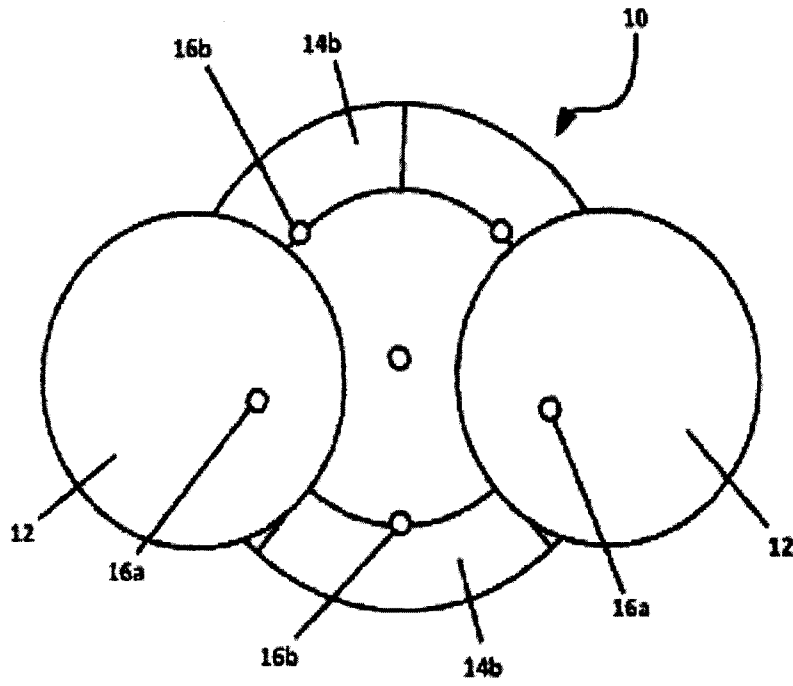

FIG. 2C
PRIOR ART

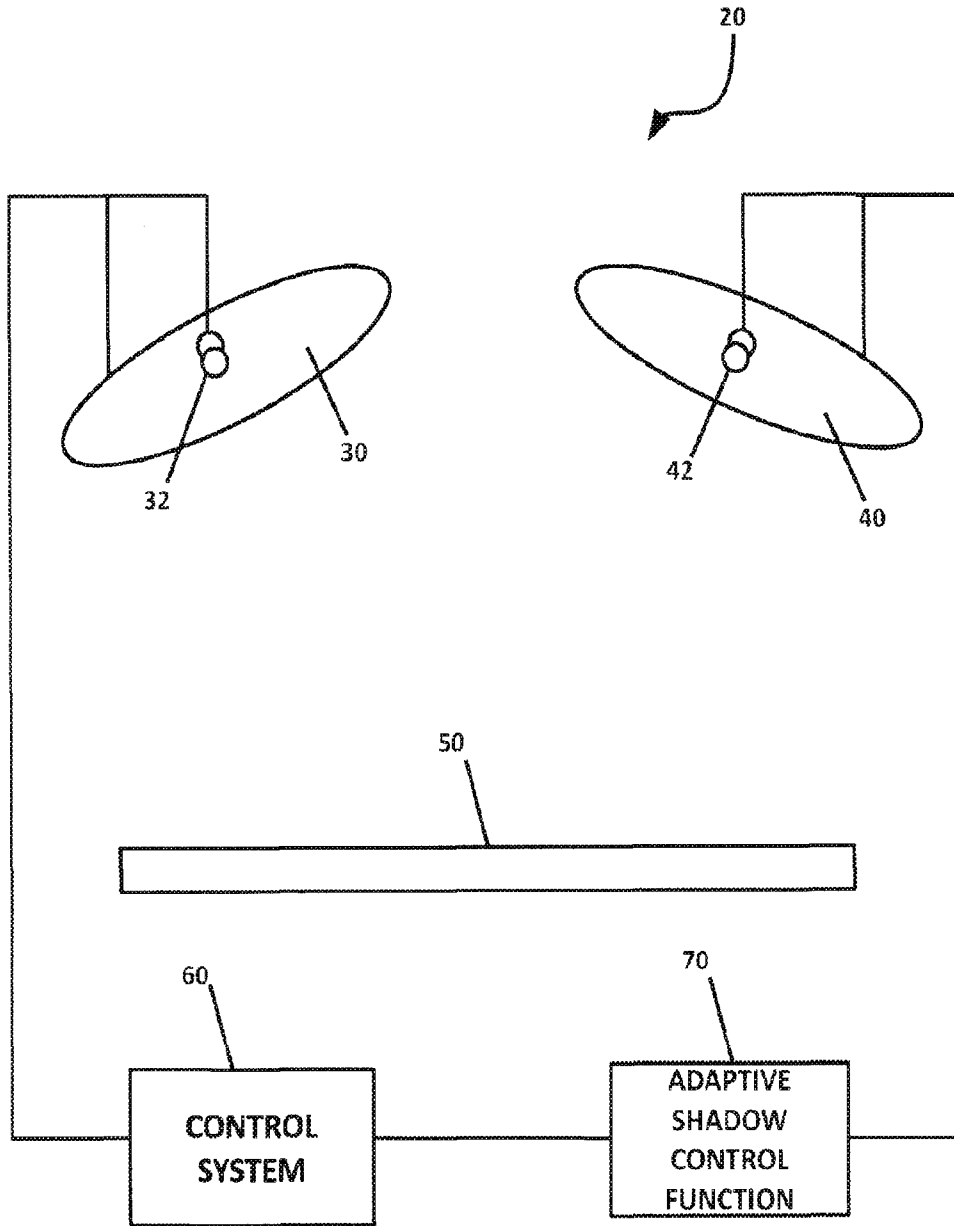

FIG. 3

5/9

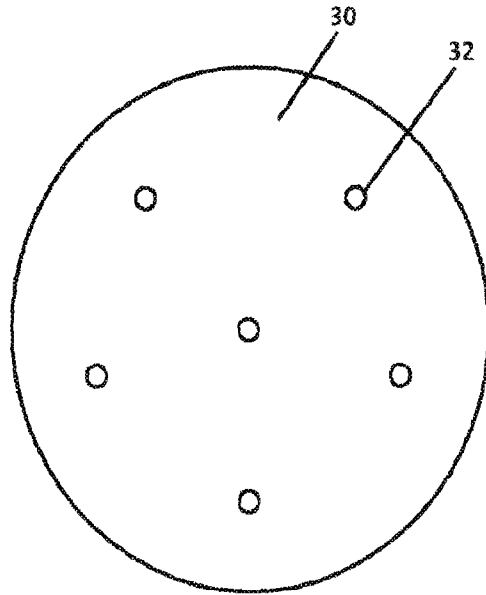

FIG. 4A

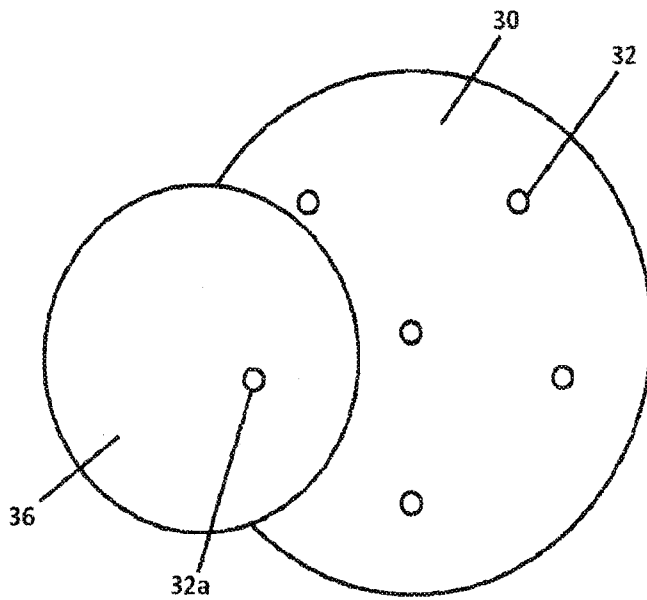

FIG. 4B

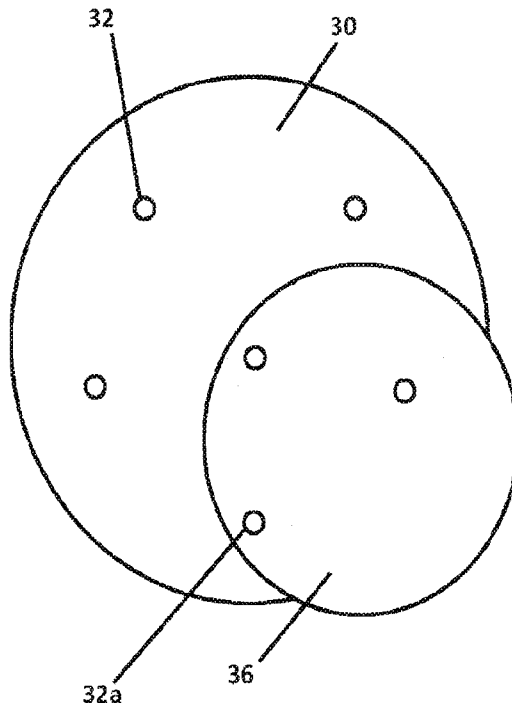

FIG. 4C

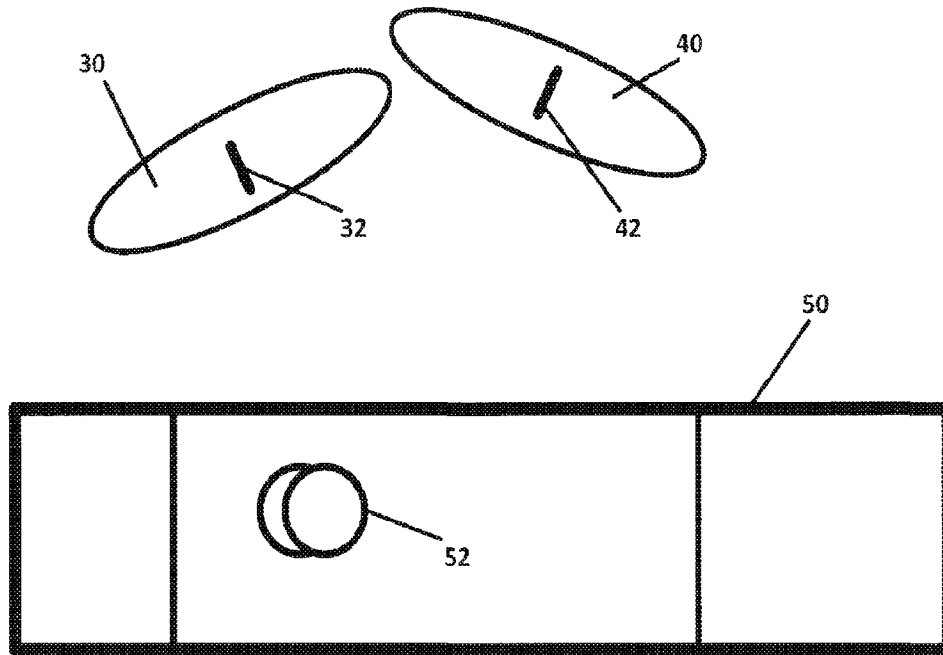

FIG. 5

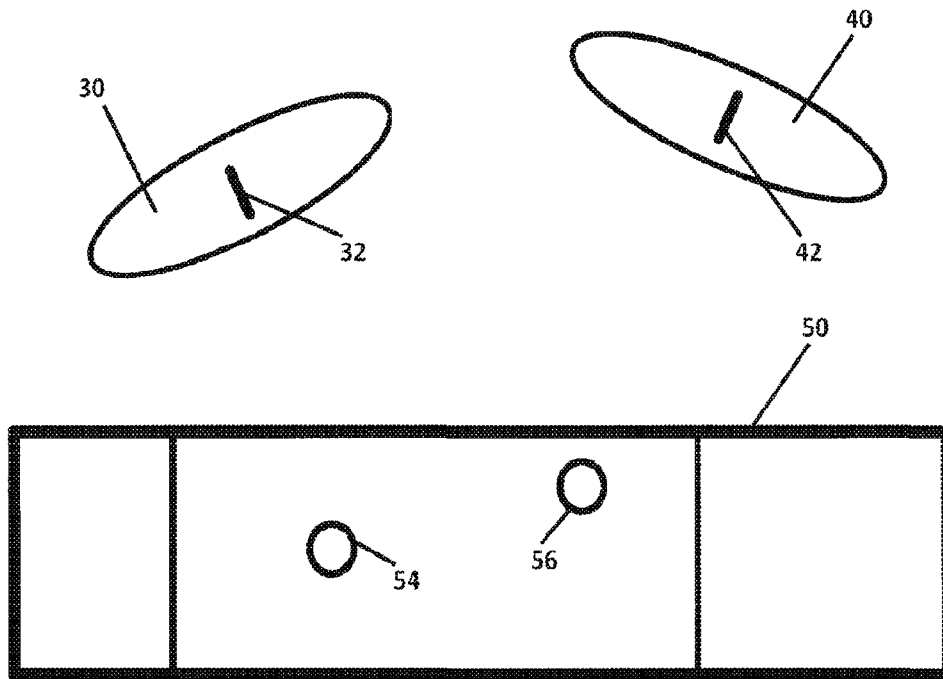

FIG. 6

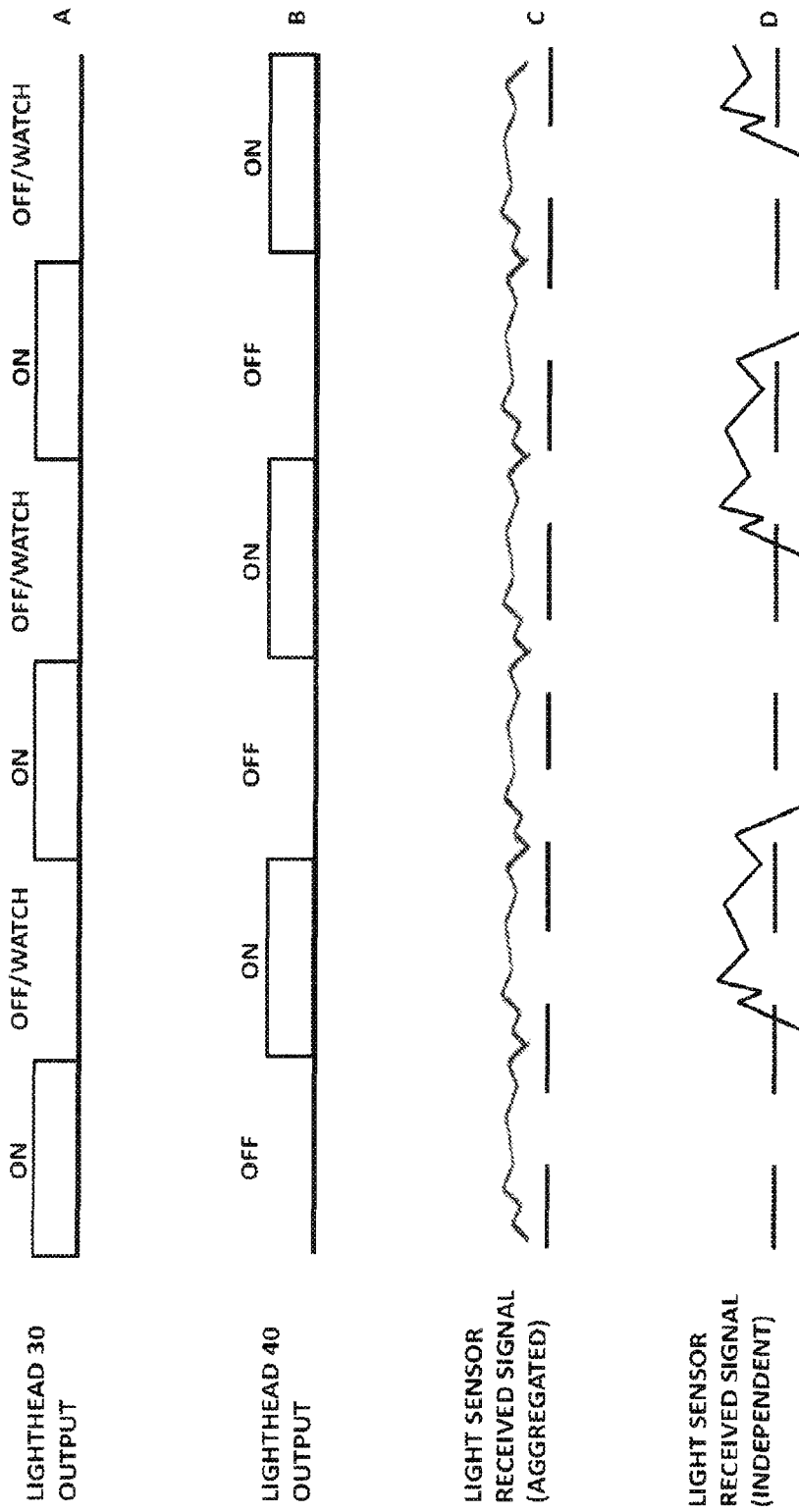

FIG. 7

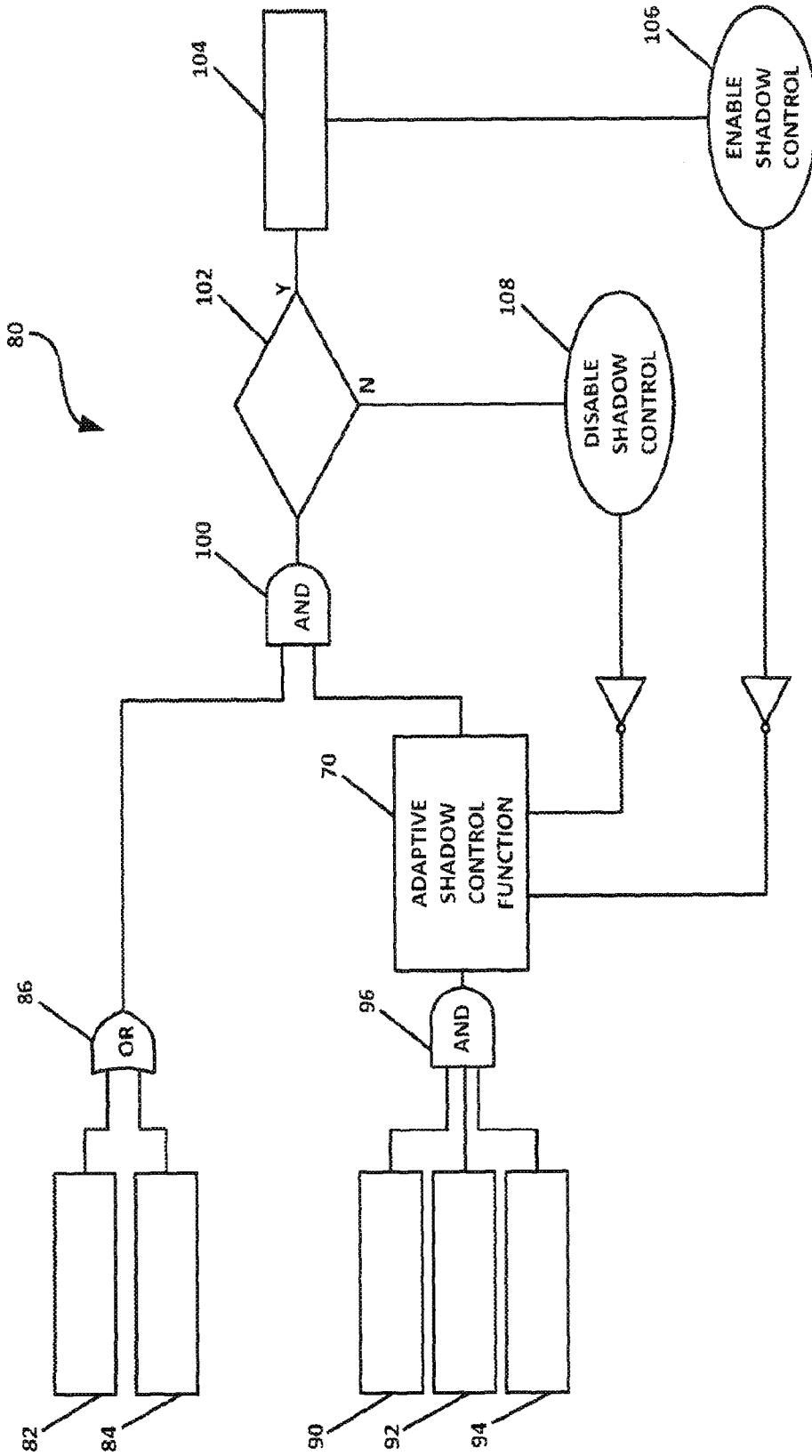

FIG. 8

