



US 20030109063A1

(19) **United States**

(12) **Patent Application Publication**  
**Santarsiero et al.**

(10) **Pub. No.: US 2003/0109063 A1**

(43) **Pub. Date: Jun. 12, 2003**

(54) **AUTOMATED  
CRYSTALLIZATION EXPERIMENT SETUP  
APPARATUS COMPRISING SENSOR**

application No. 09/336,134, filed on Jun. 18, 1999,  
now Pat. No. 6,296,673.

**Publication Classification**

(76) Inventors: **Bernard D. Santarsiero**, Chicago, IL  
(US); **Raymond C. Stevens**, La Jolla,  
CA (US); **Peter G. Schultz**, La Jolla,  
CA (US); **Joseph M. Jaklevic**,  
Lafayette, CA (US); **Derek T. Yegian**,  
Oakland, CA (US); **Earl W. Cornell**,  
Antioch, CA (US); **Robert A.  
Nordmeyer**, San Leandro, CA (US)

(51) **Int. Cl.<sup>7</sup>** ..... **G01N 33/543**; G06F 19/00;  
G01N 33/48; G01N 33/50;  
G06K 9/00  
(52) **U.S. Cl.** ..... **436/518**; 23/295 R; 702/19;  
382/128

Correspondence Address:

**Howard M. Peters**  
**PETERS, VERNY, JONES & SCHMITT L.L.P.**  
**Suite 6**  
**385 Sherman Avenue**  
**Palo Alto, CA 94306 (US)**

(57) **ABSTRACT**

A method is provided for performing array microcrystallizations to determine suitable crystallization conditions for a molecule, the method comprising: forming an array of microcrystallizations, each microcrystallization comprising a drop comprising a mother liquor solution whose composition varies within the array and a molecule to be crystallized, the drop having a volume of less than 1 microliter; storing the array of microcrystallizations under conditions suitable for molecule crystals to form in the drops in the array; and detecting molecule crystal formation in the drops by taking images of the drops.

(21) Appl. No.: **10/323,037**

(22) Filed: **Dec. 18, 2002**

**Related U.S. Application Data**

(63) Continuation of application No. 09/851,397, filed on  
May 7, 2001, which is a continuation-in-part of

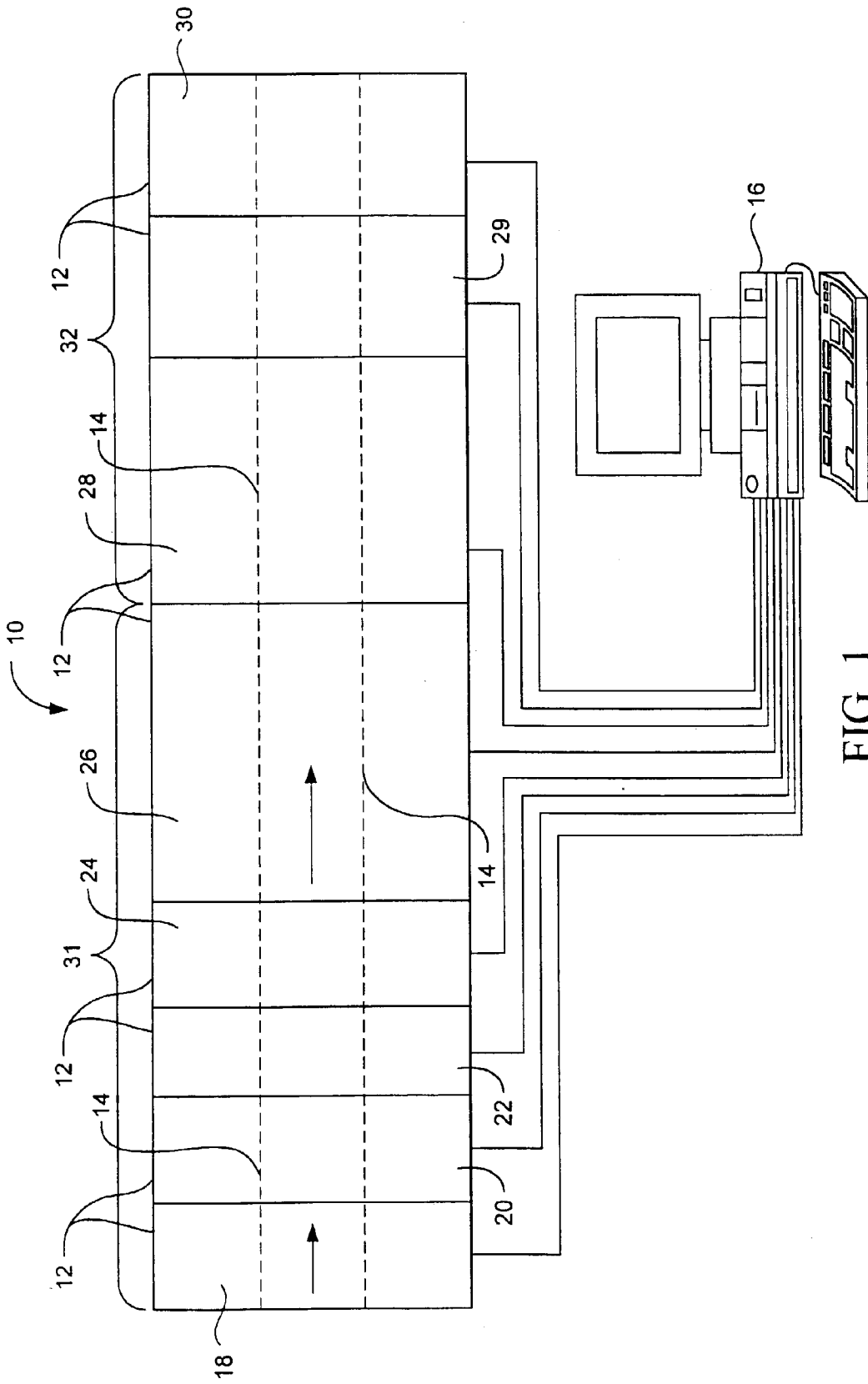

FIG. 1

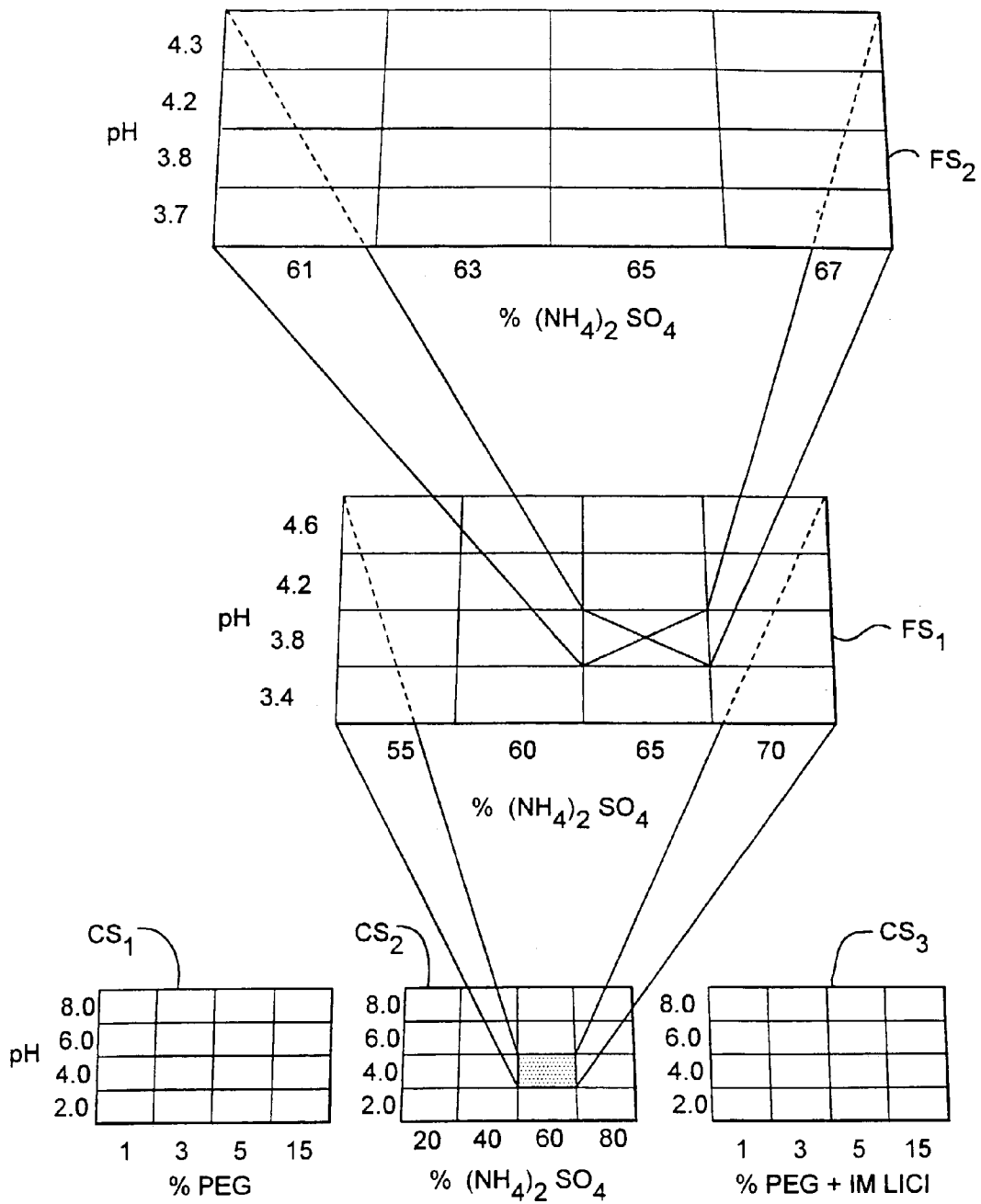

FIG. 2

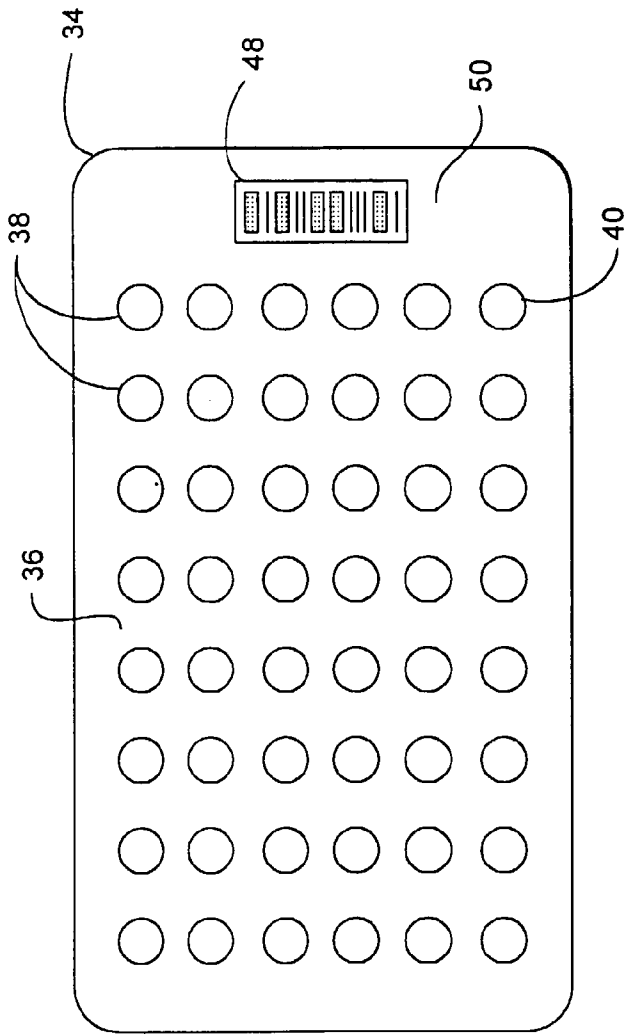

FIG. 3A

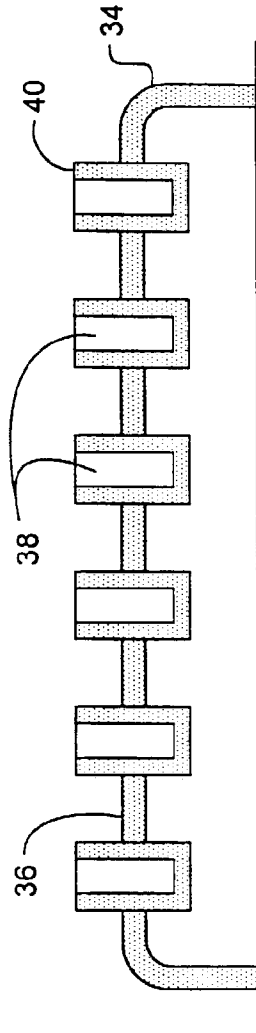

FIG. 3B

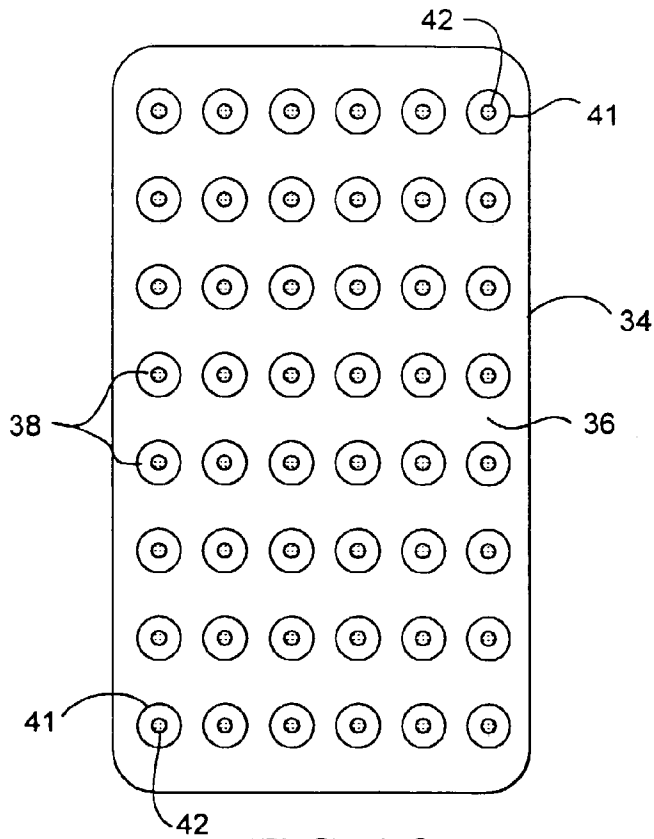

FIG. 3C

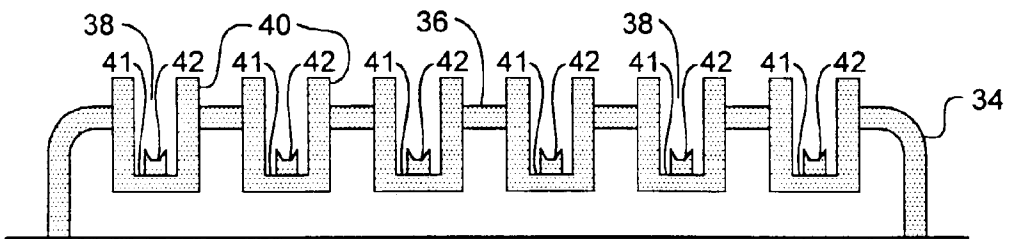

FIG. 3D

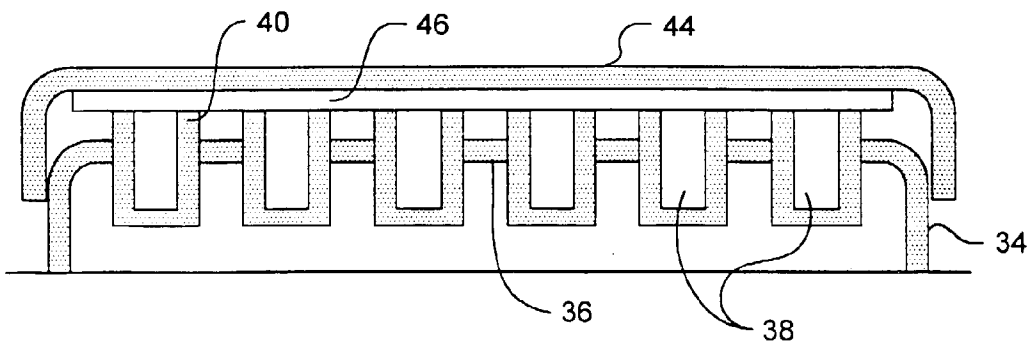

FIG. 3E

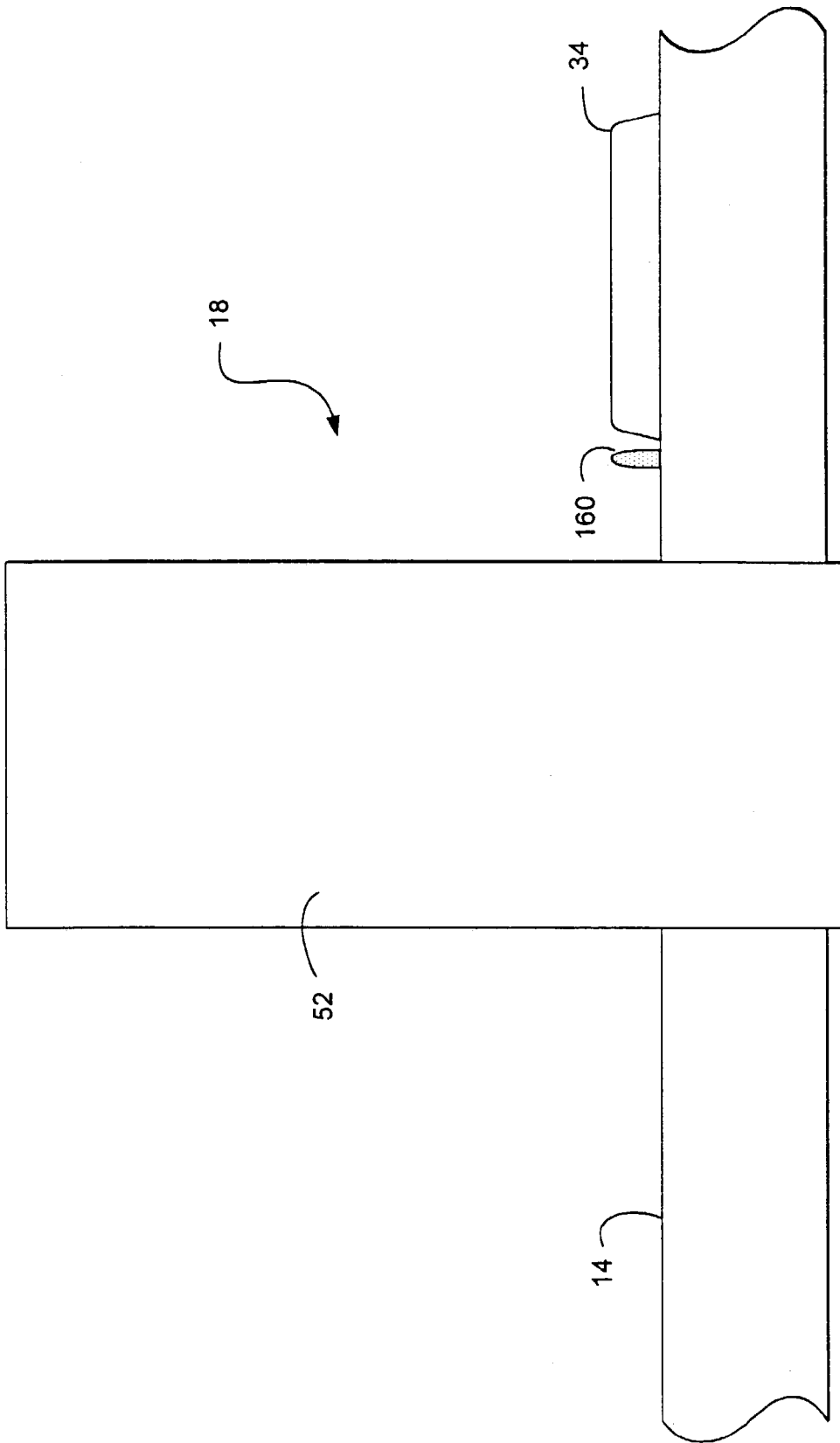

FIG. 4A

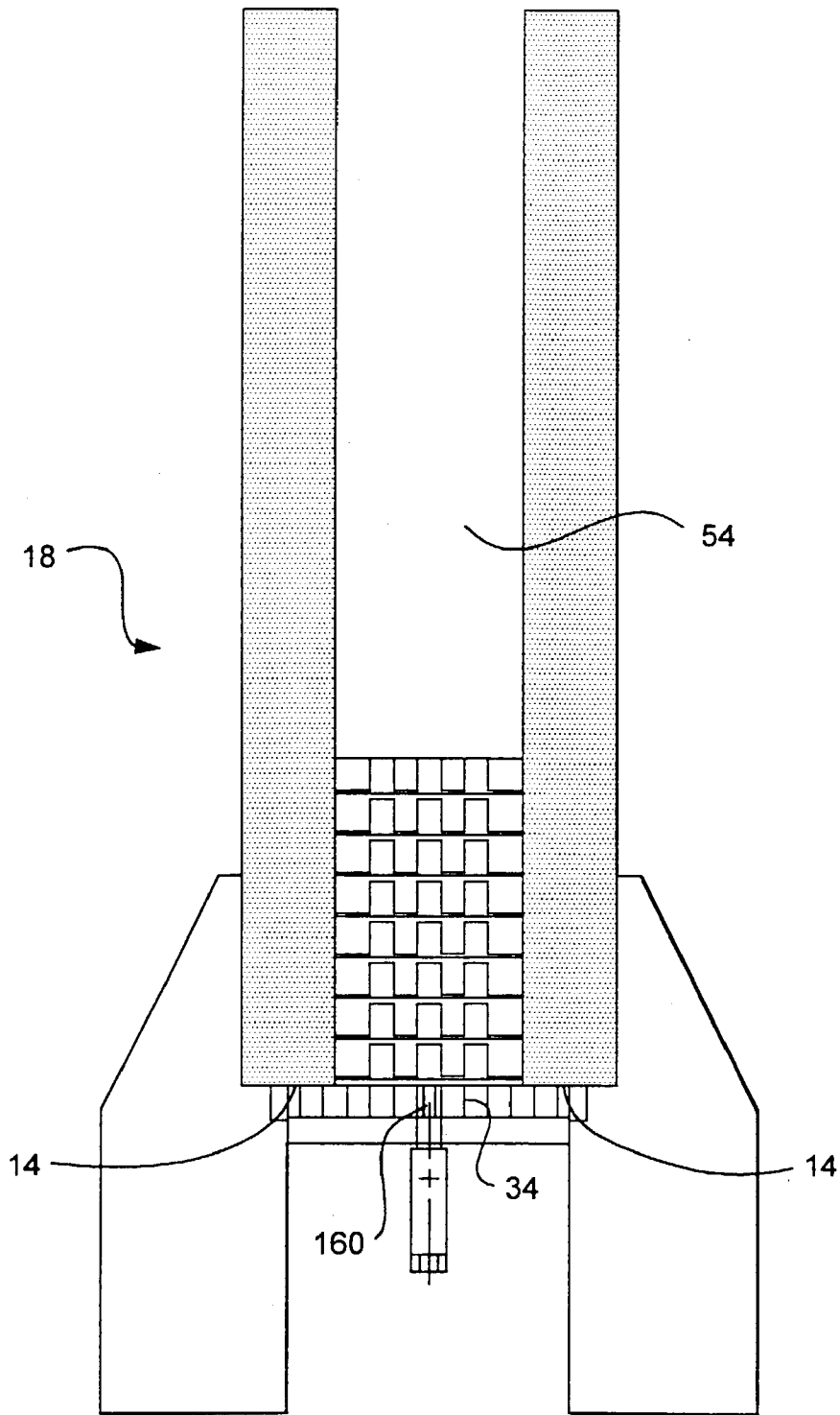

FIG. 4B

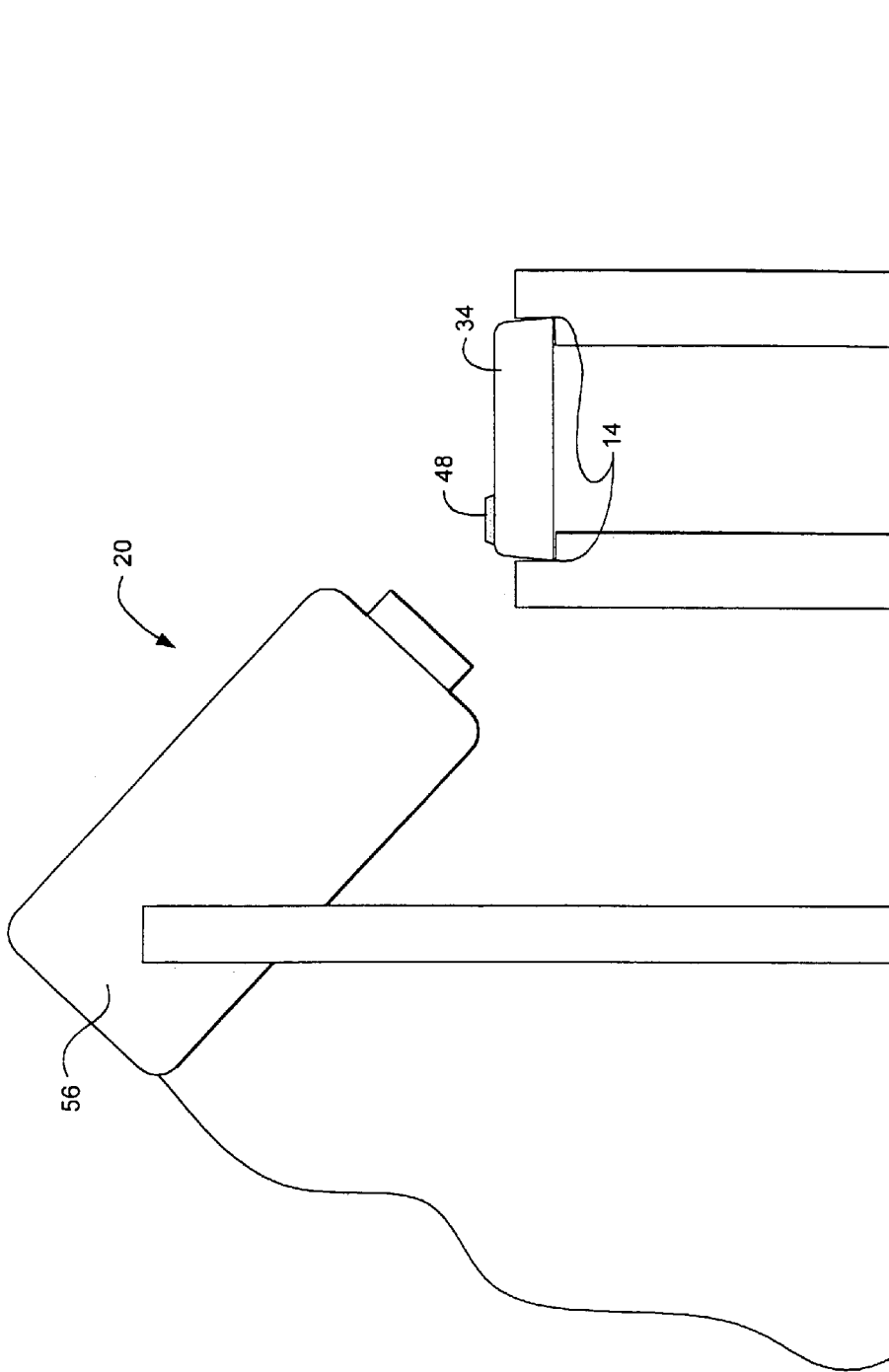

FIG. 4C



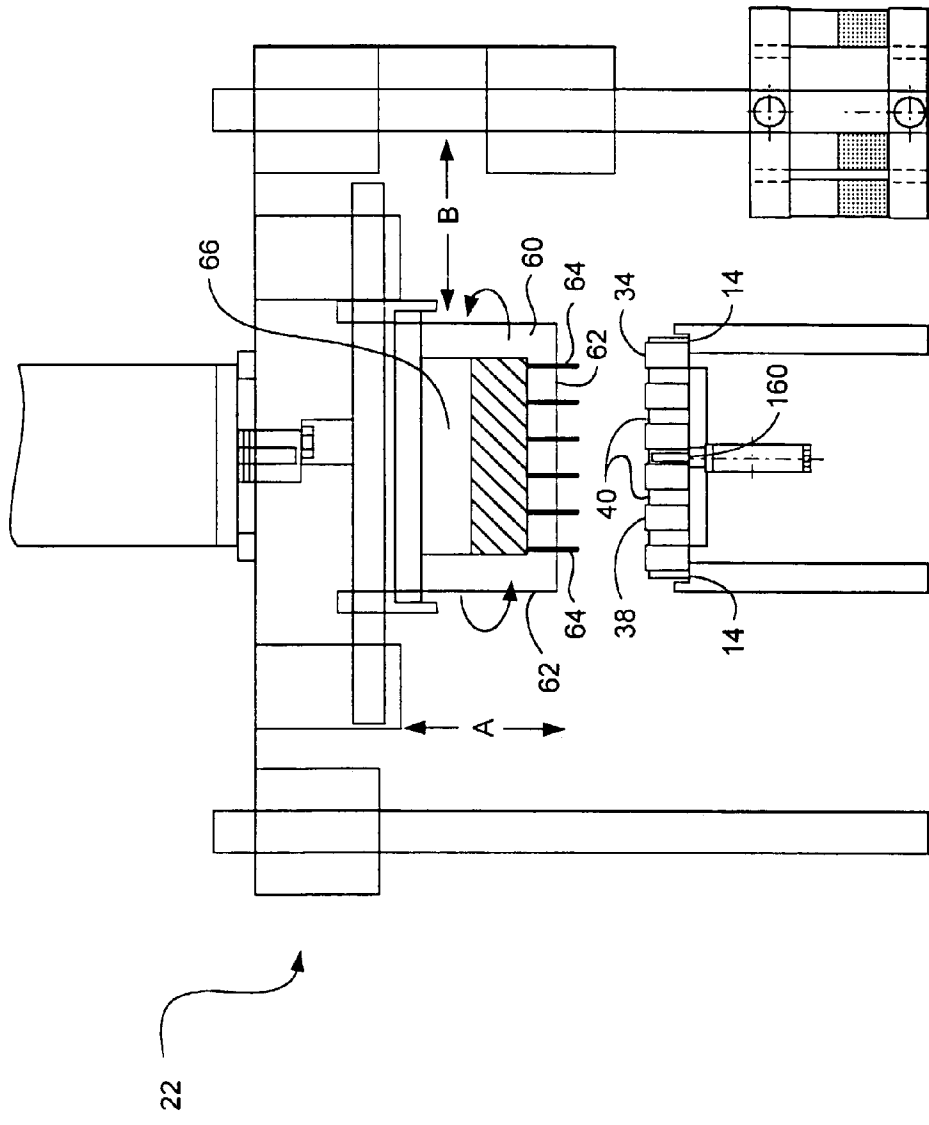

FIG. 4D

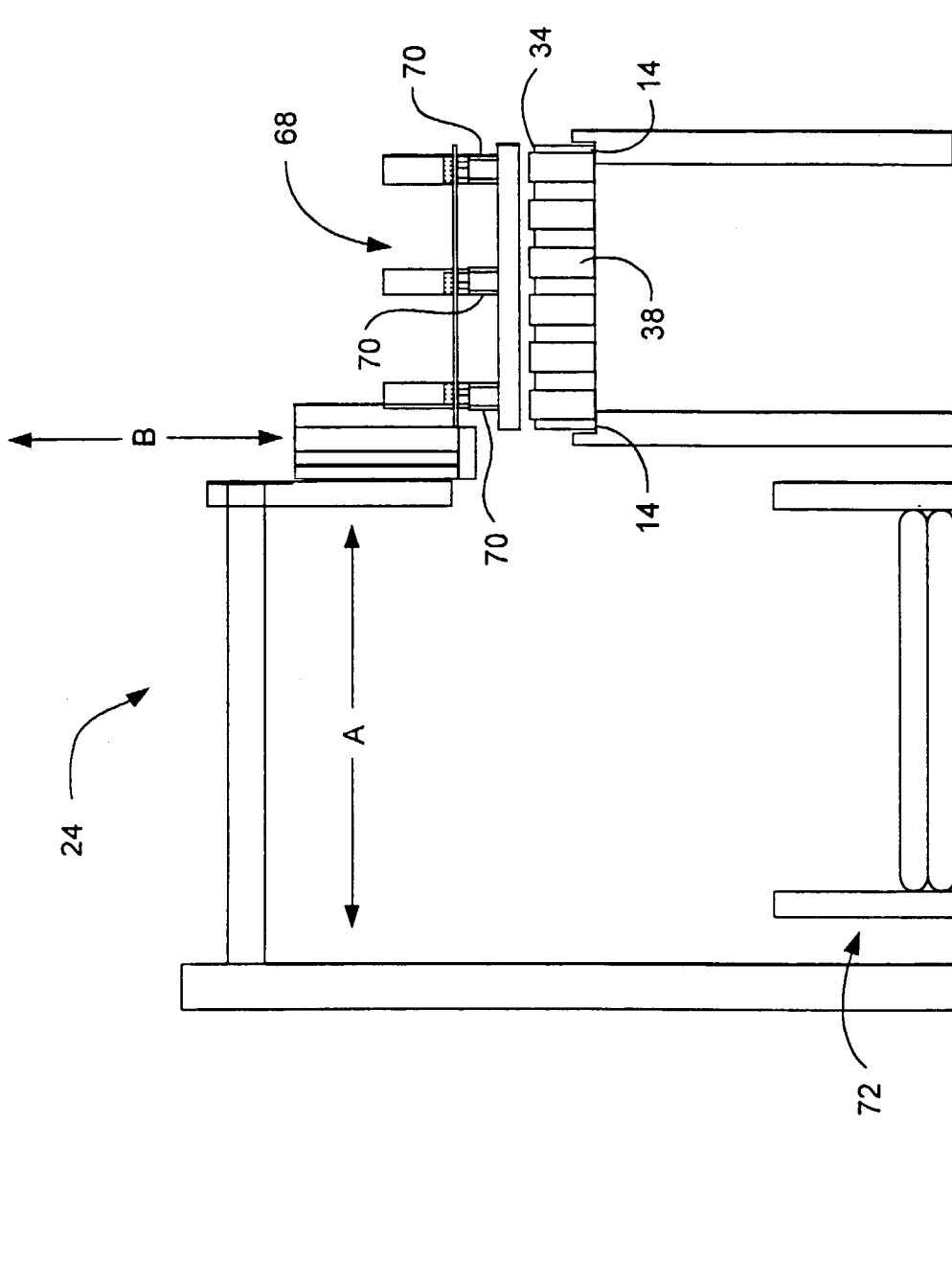

FIG. 4E

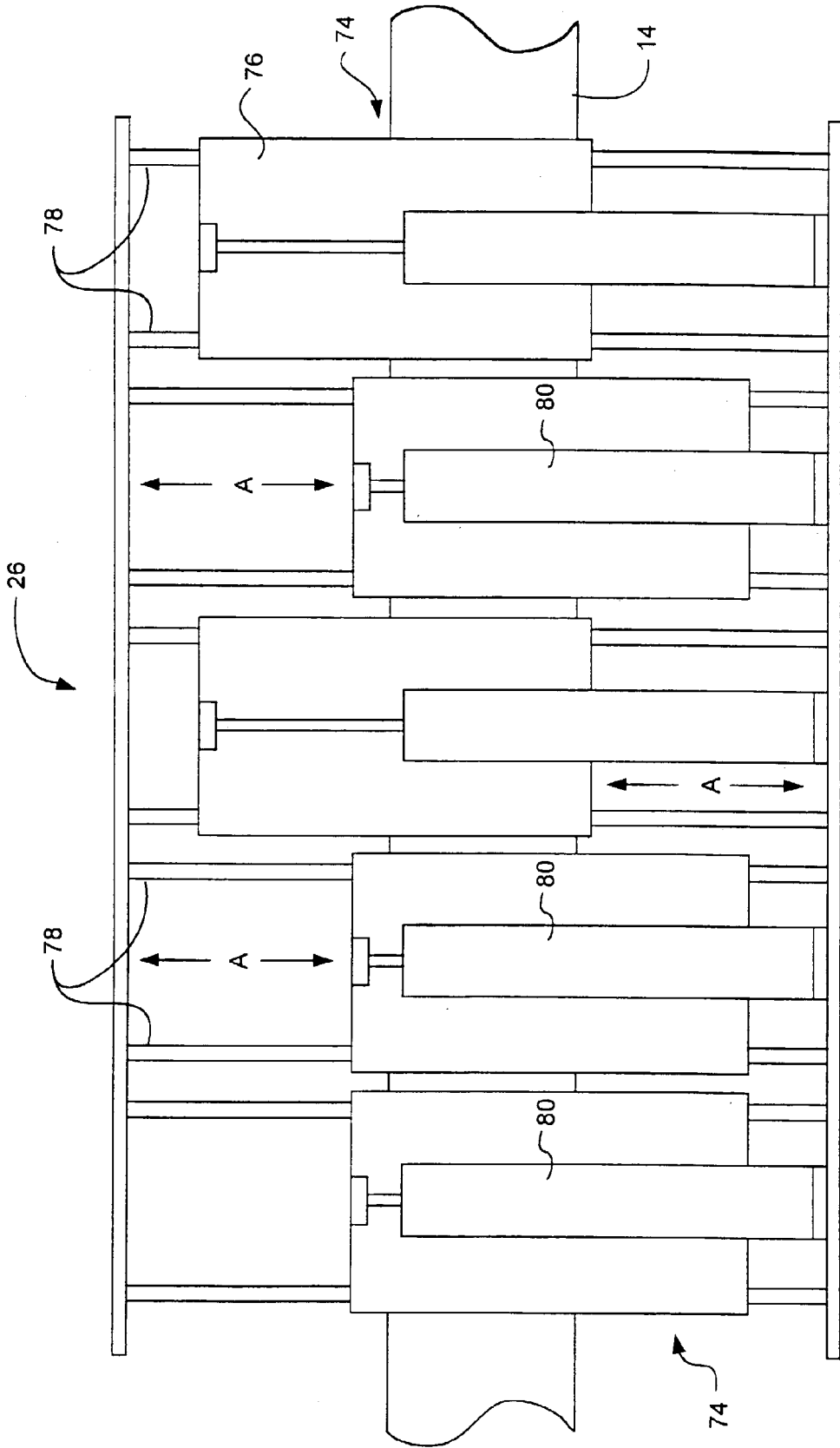

FIG. 4F

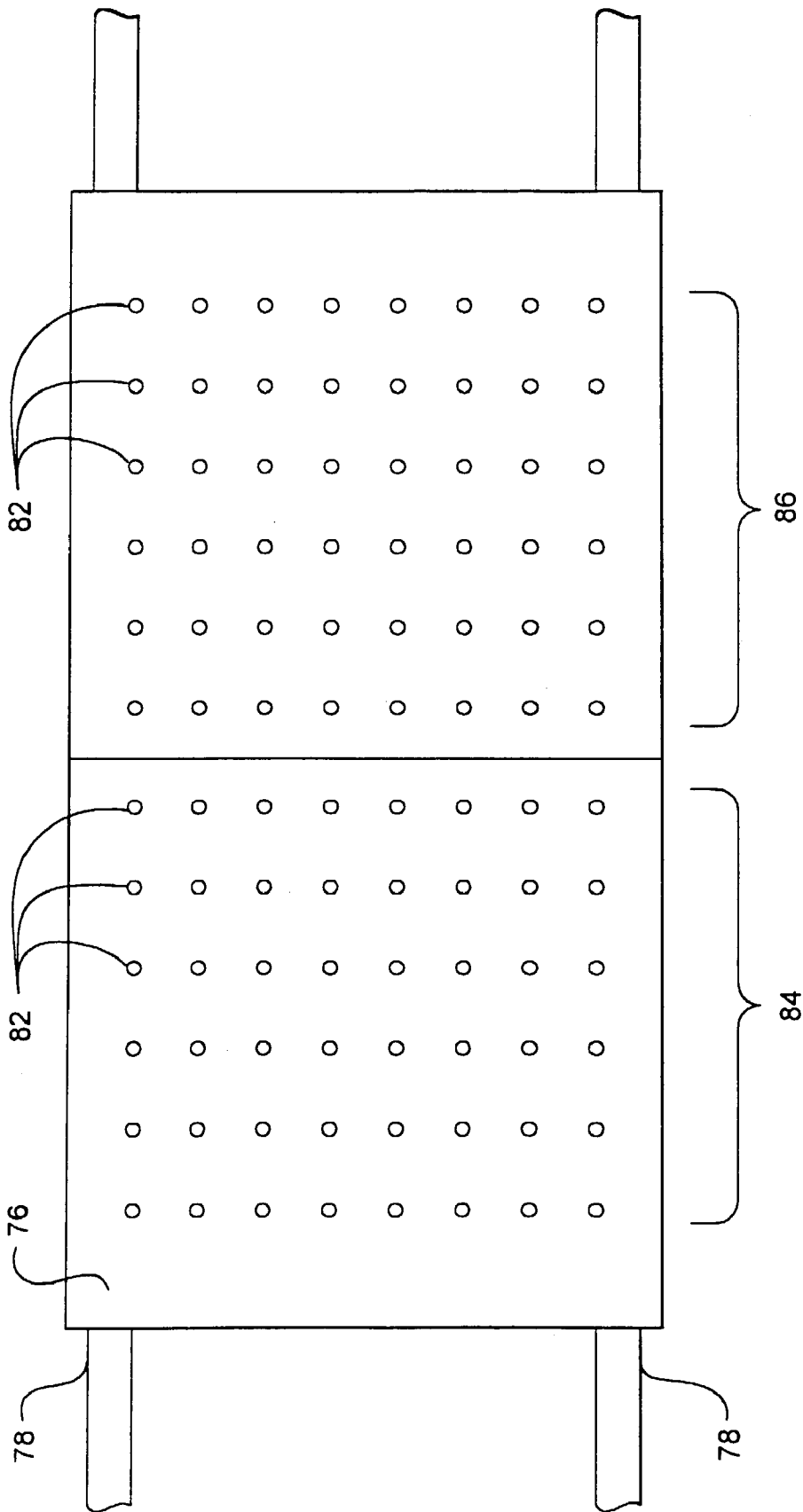

FIG. 4G

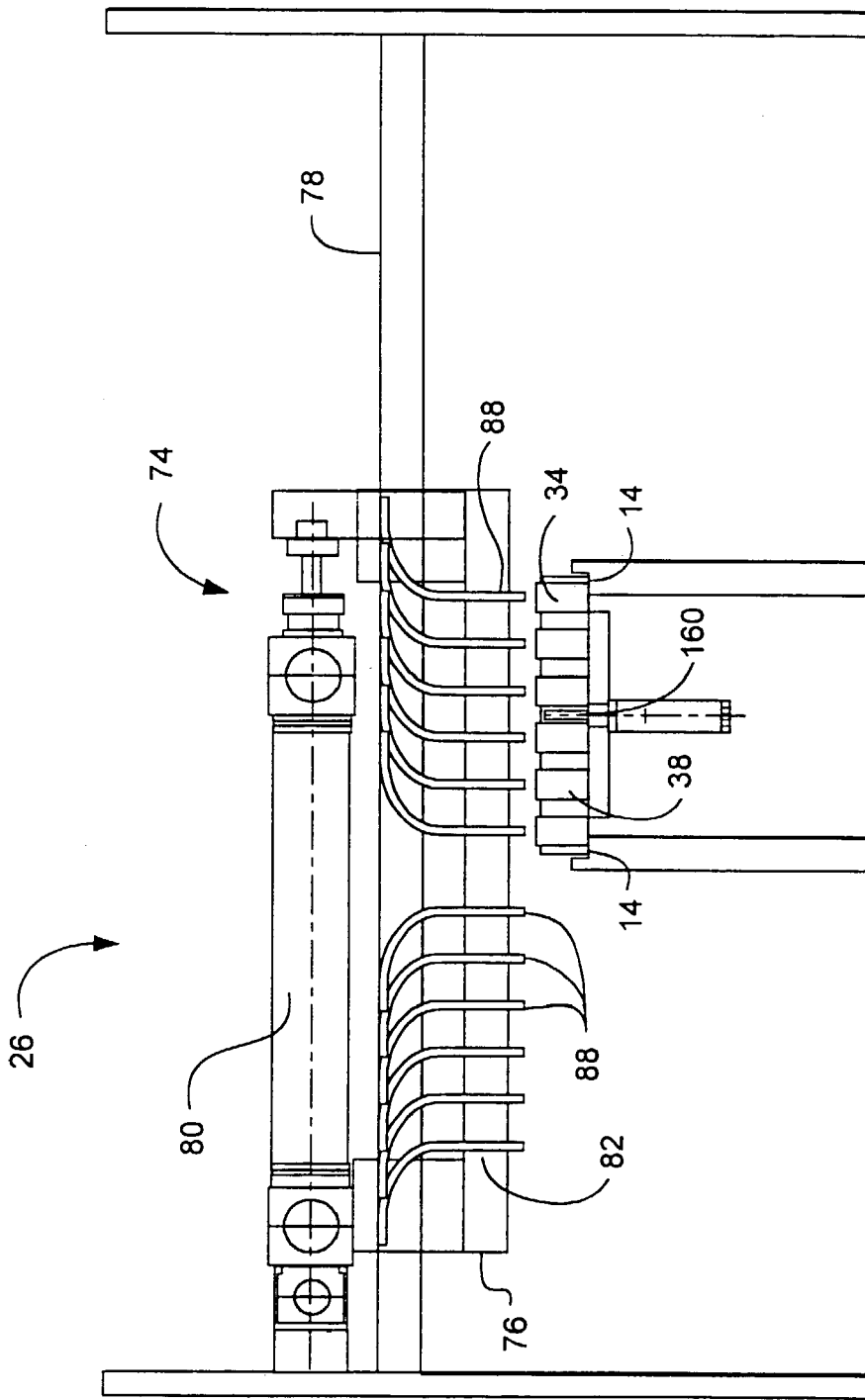

FIG. 4H

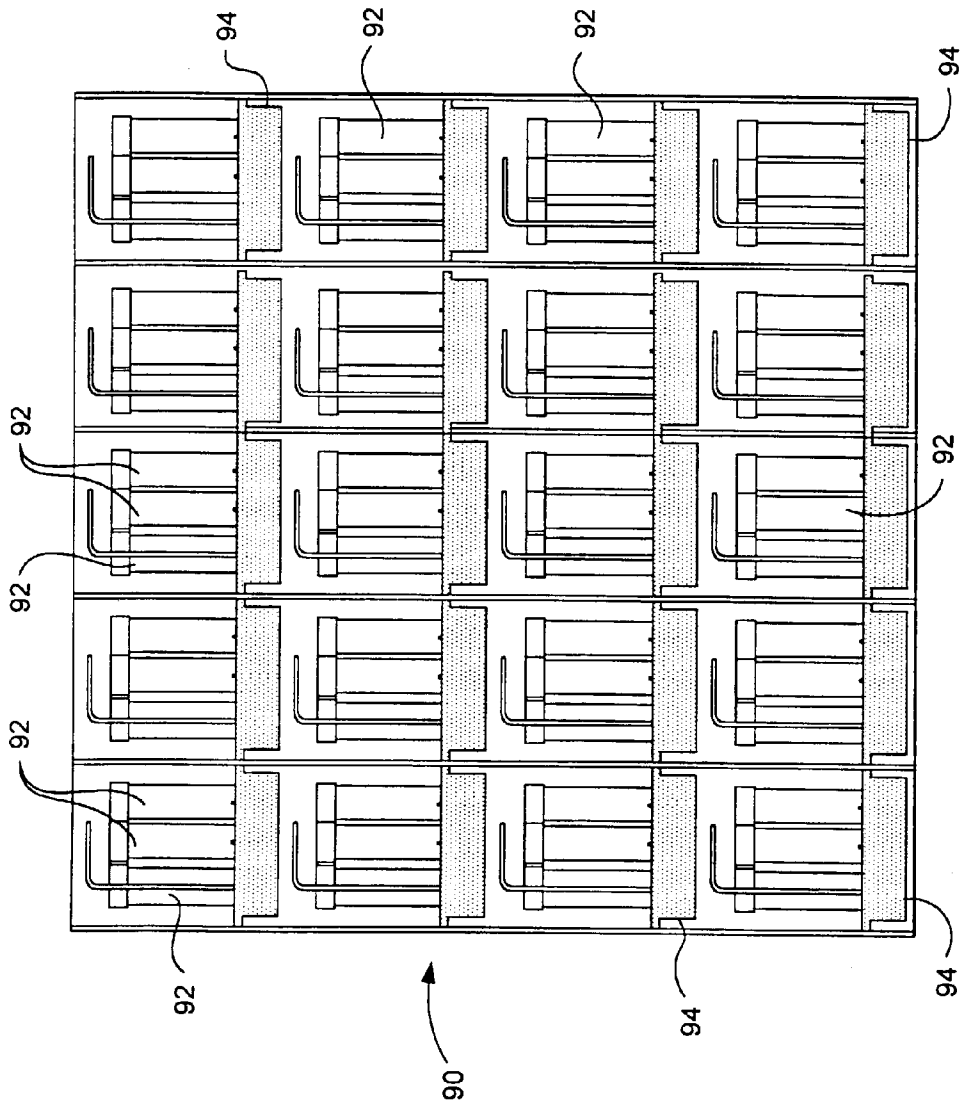

FIG. 4I

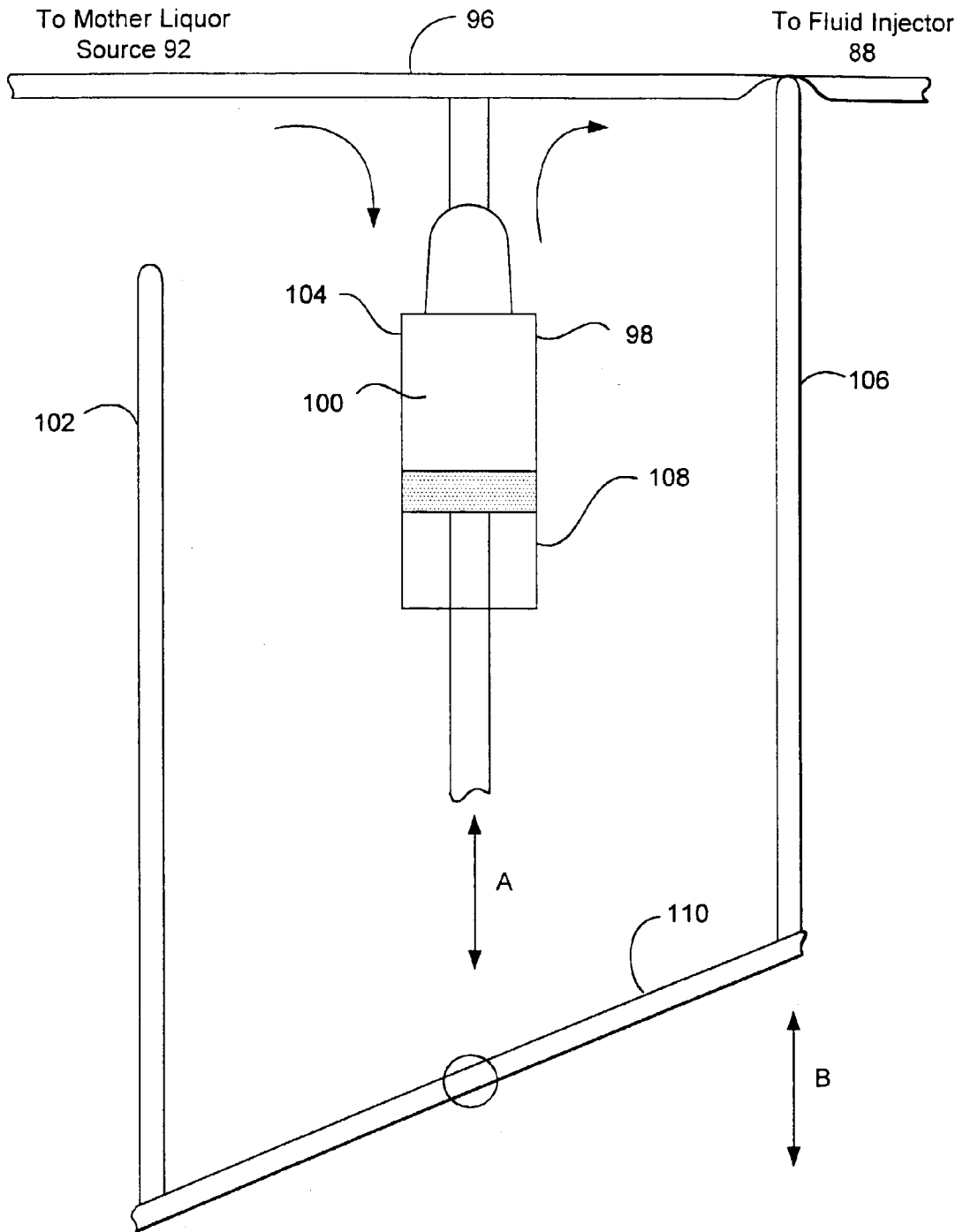

FIG. 4J

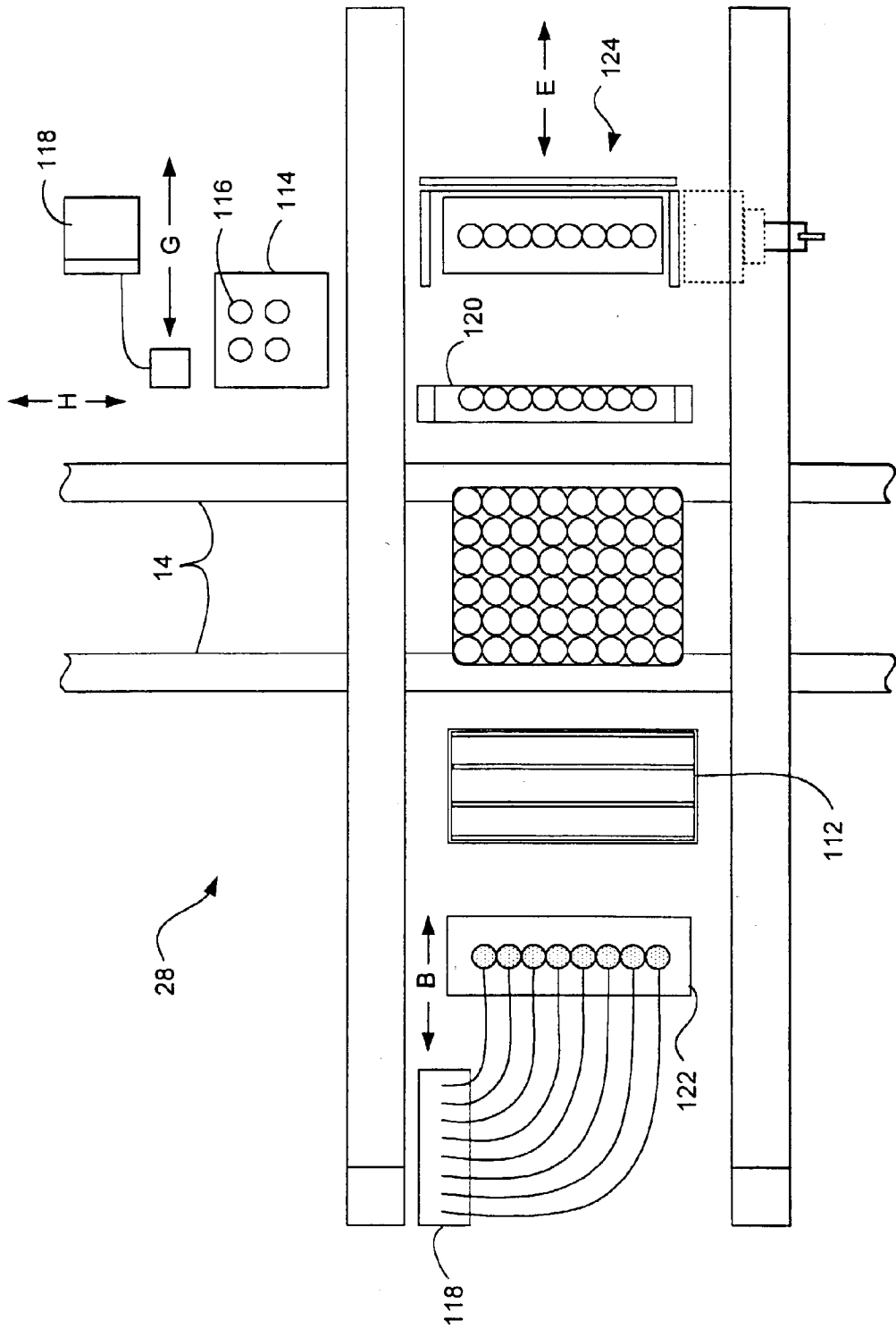

FIG. 5A



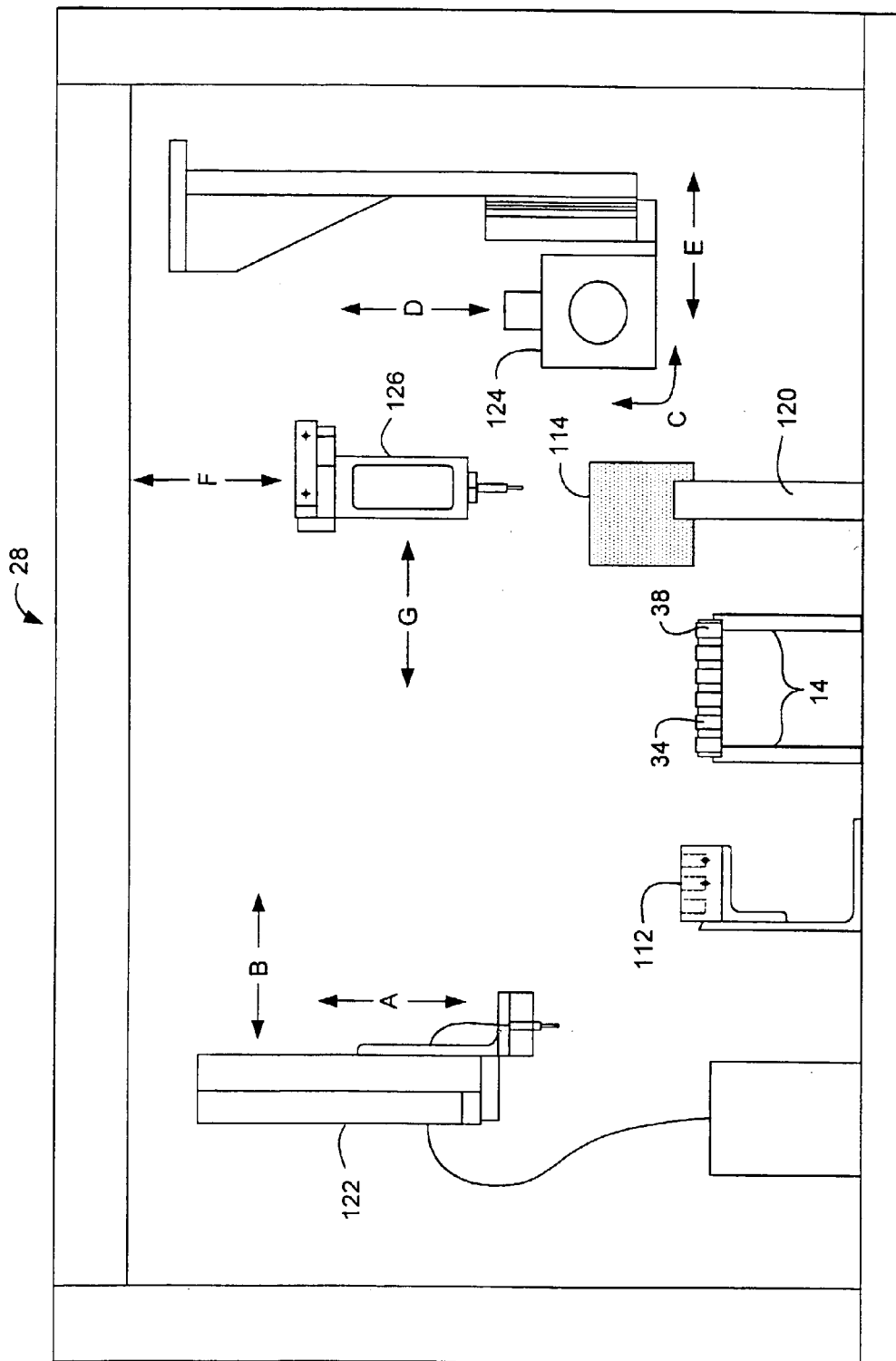

FIG. 5B

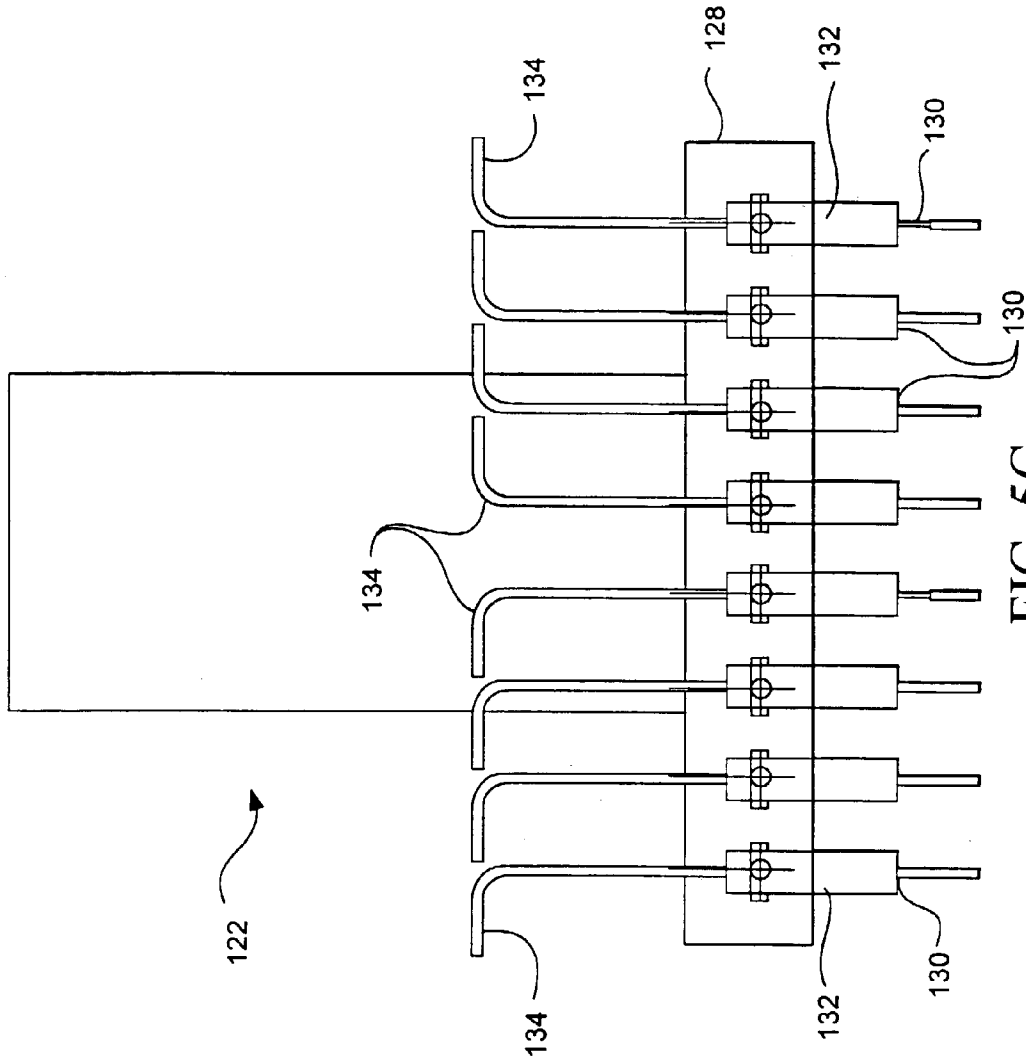

FIG. 5C

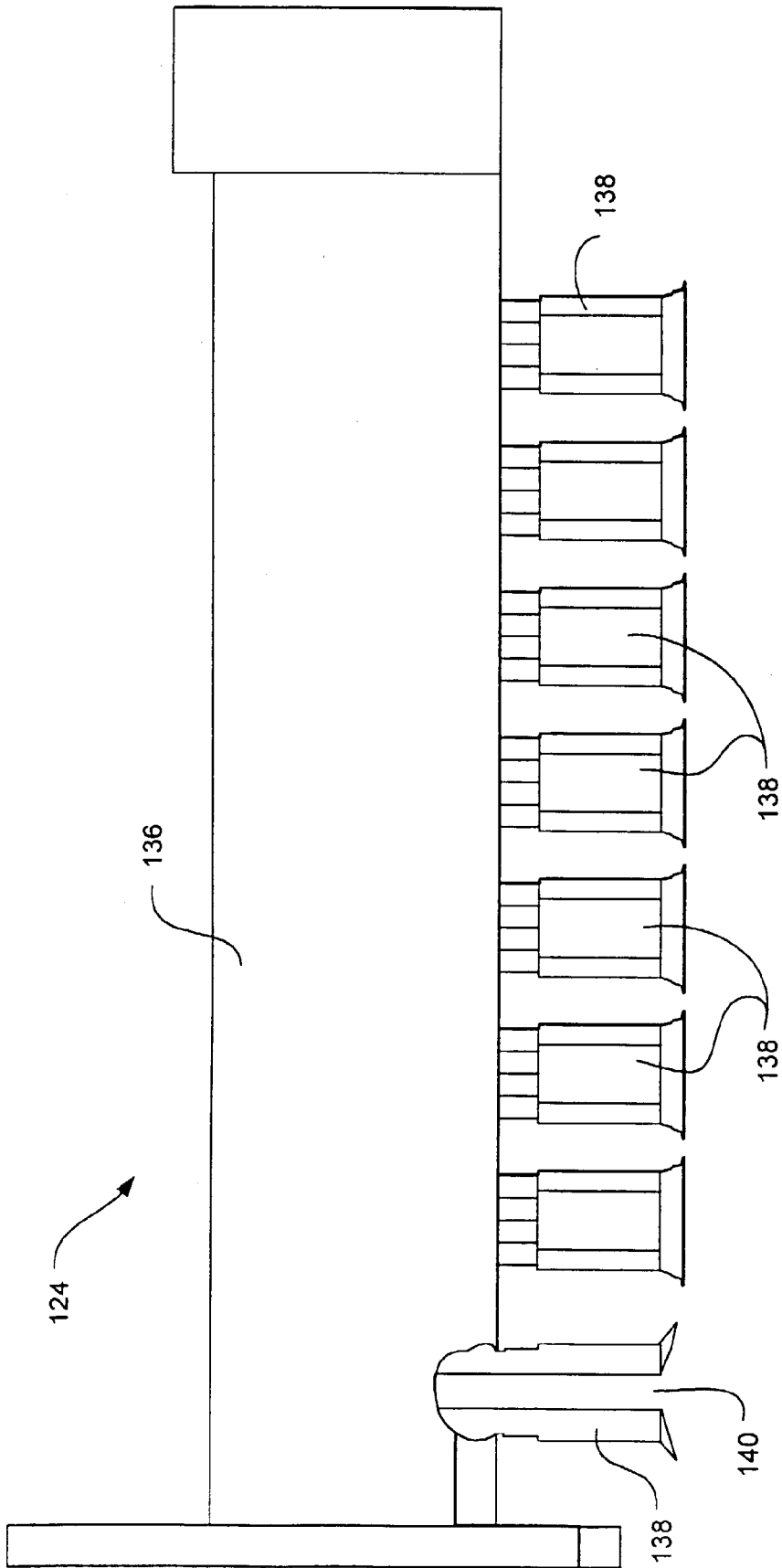

FIG. 5D

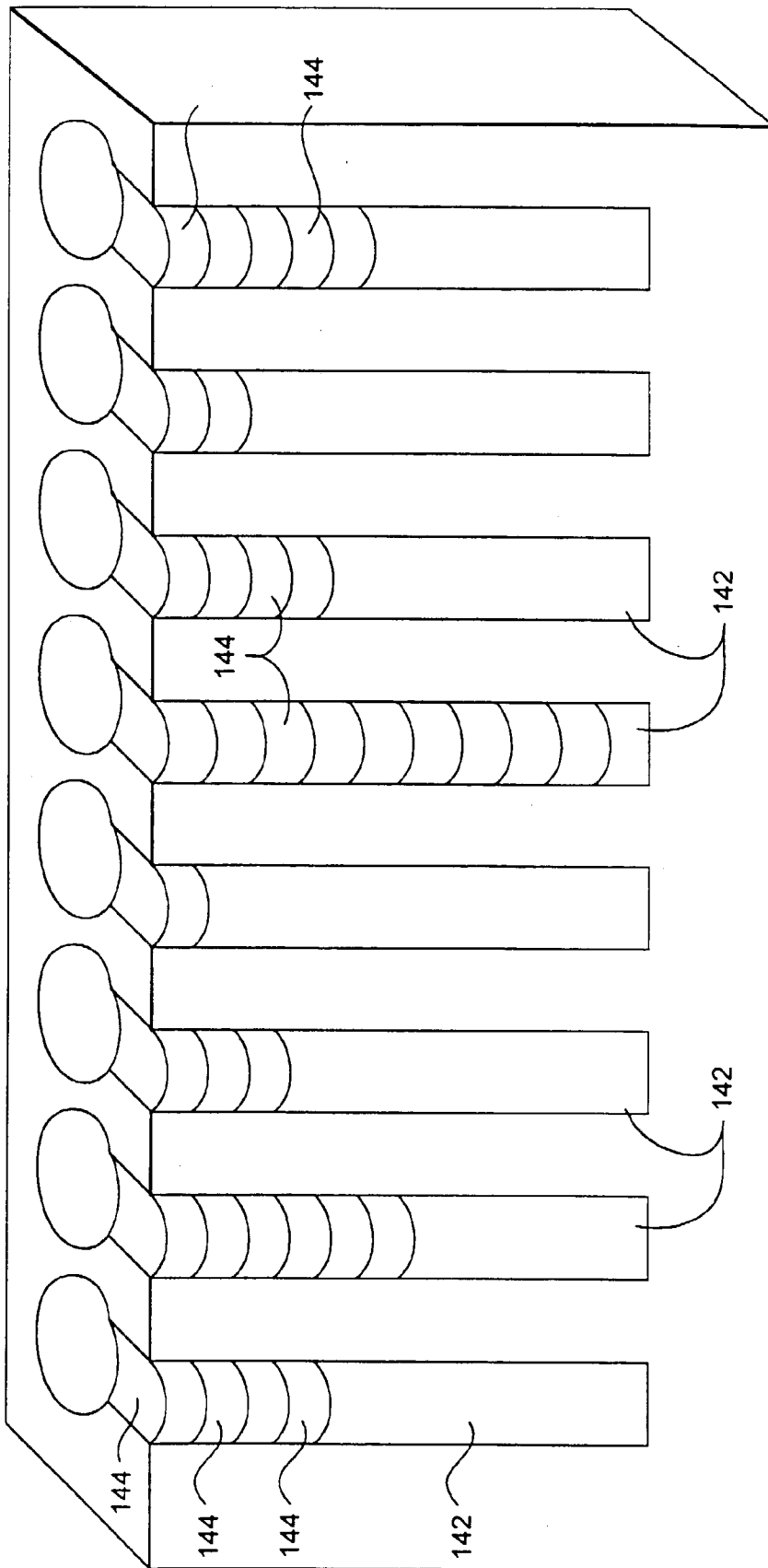

FIG. 5E

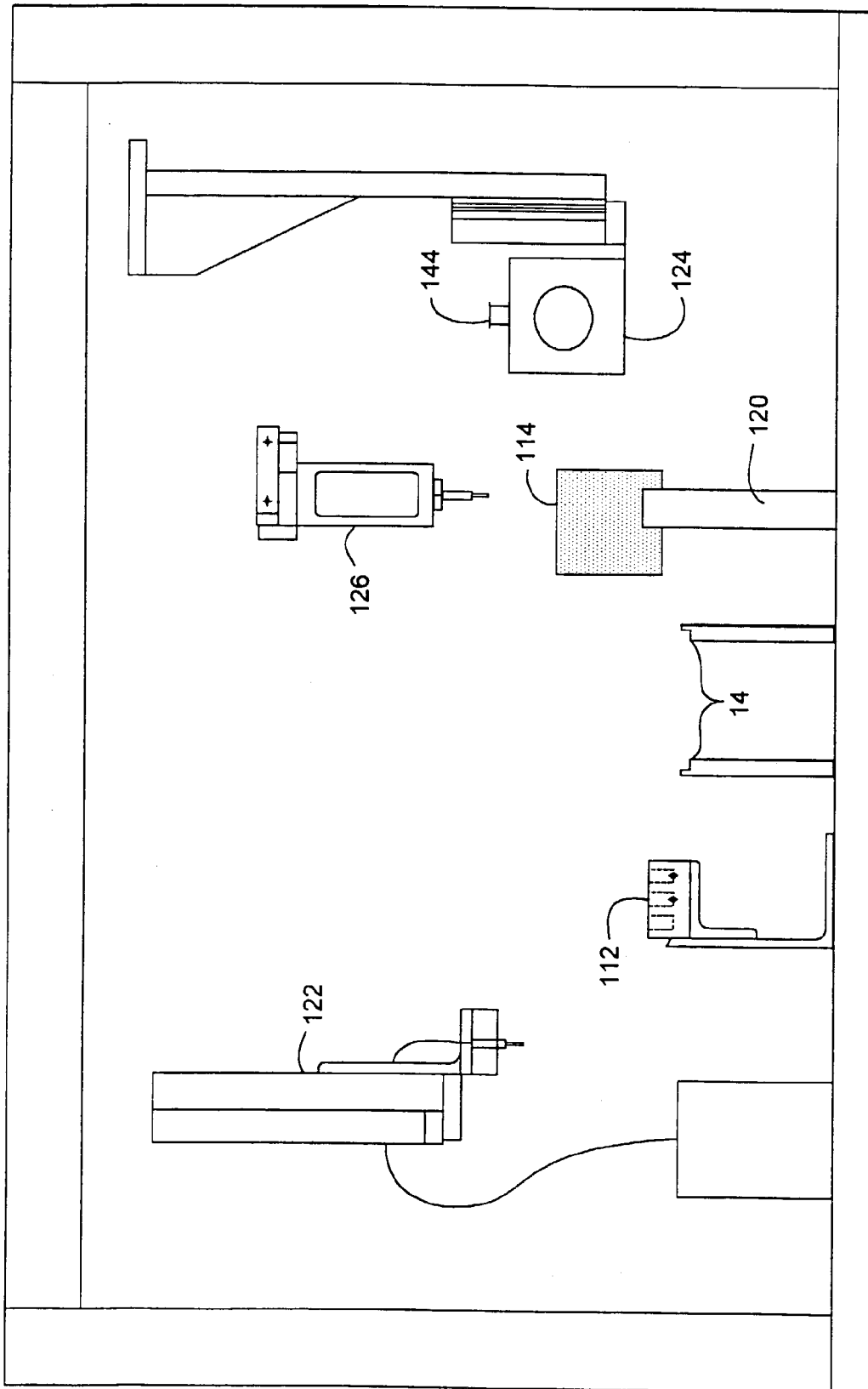

FIG. 6A

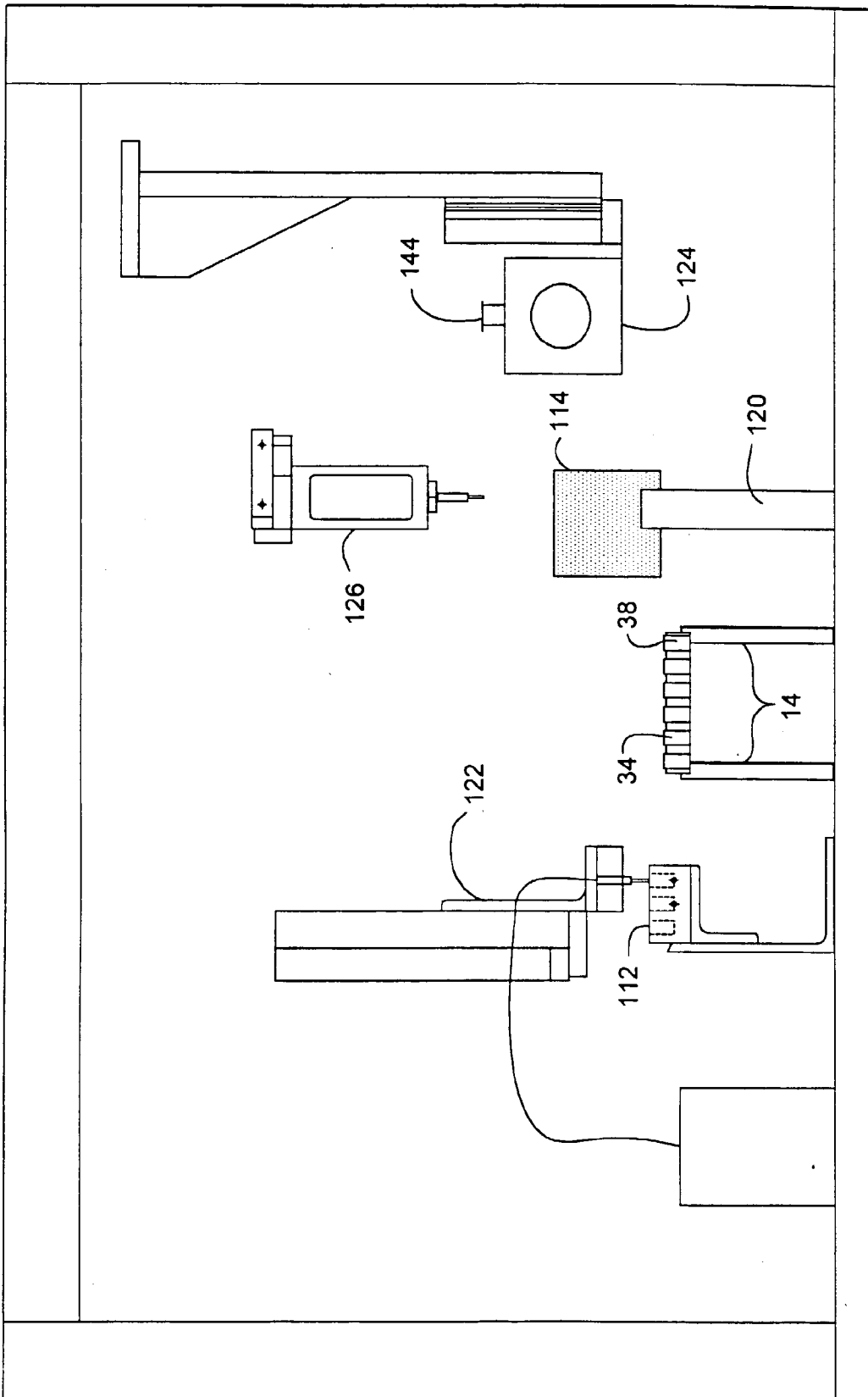

FIG. 6B

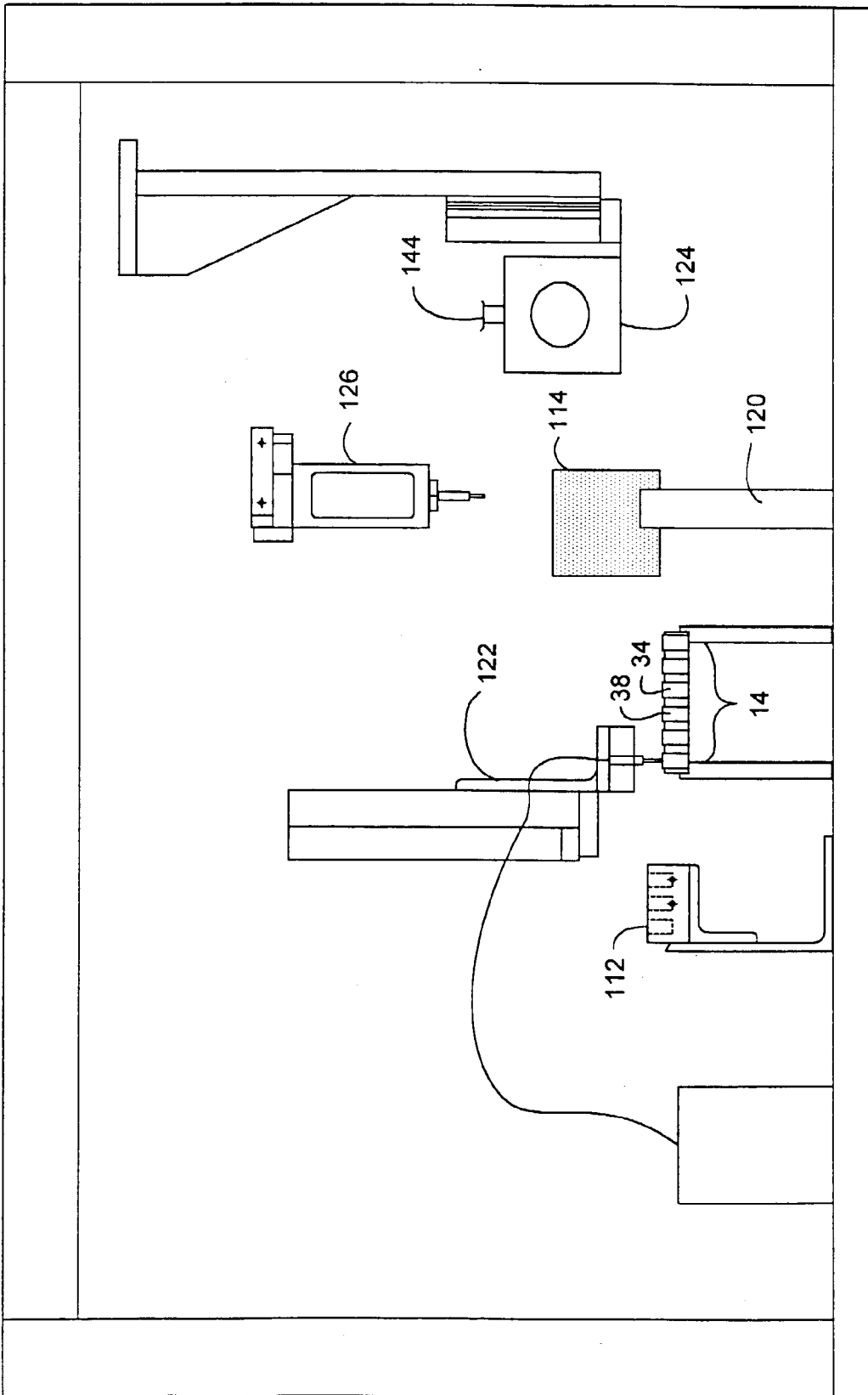

FIG. 6C

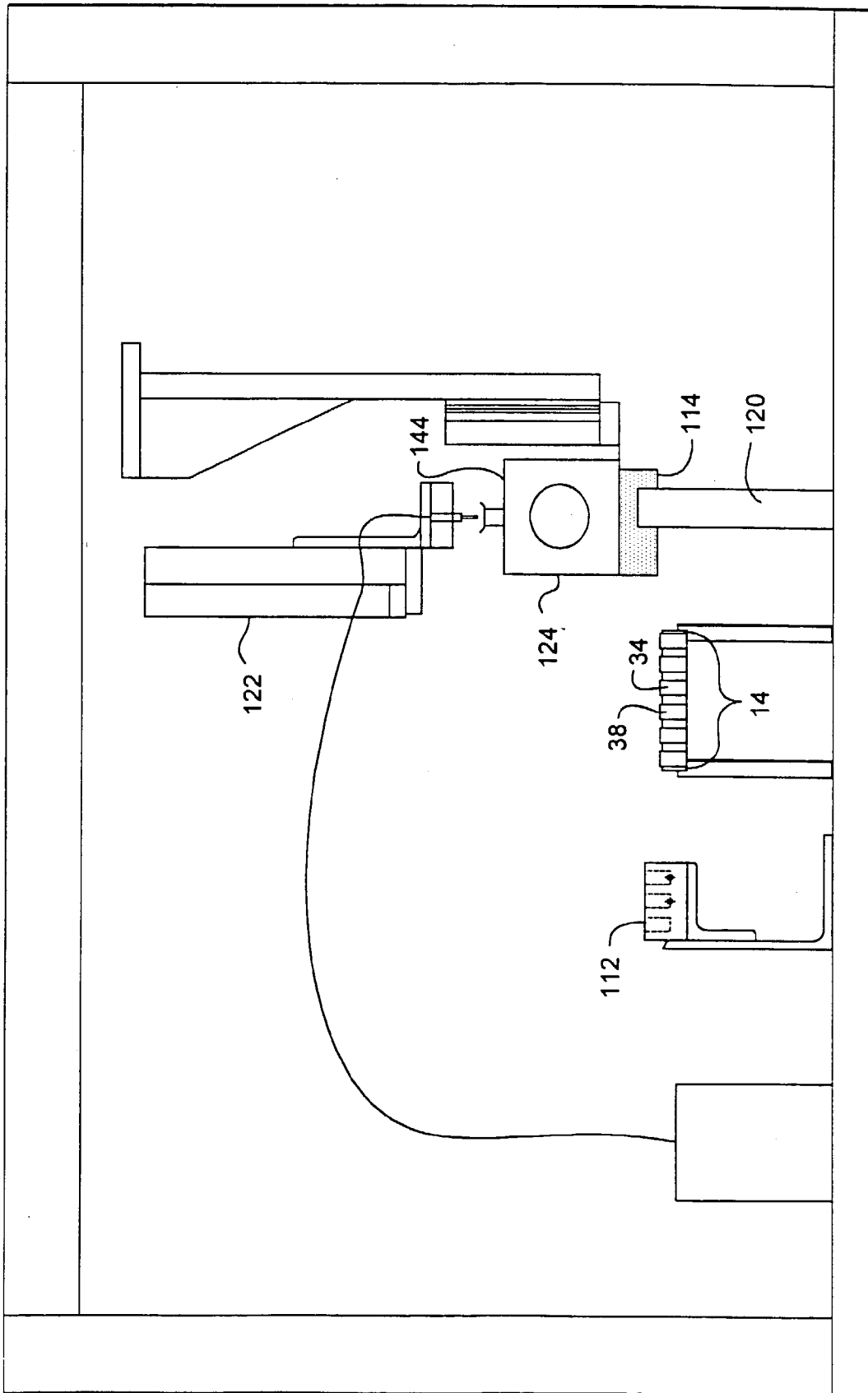

FIG. 6D



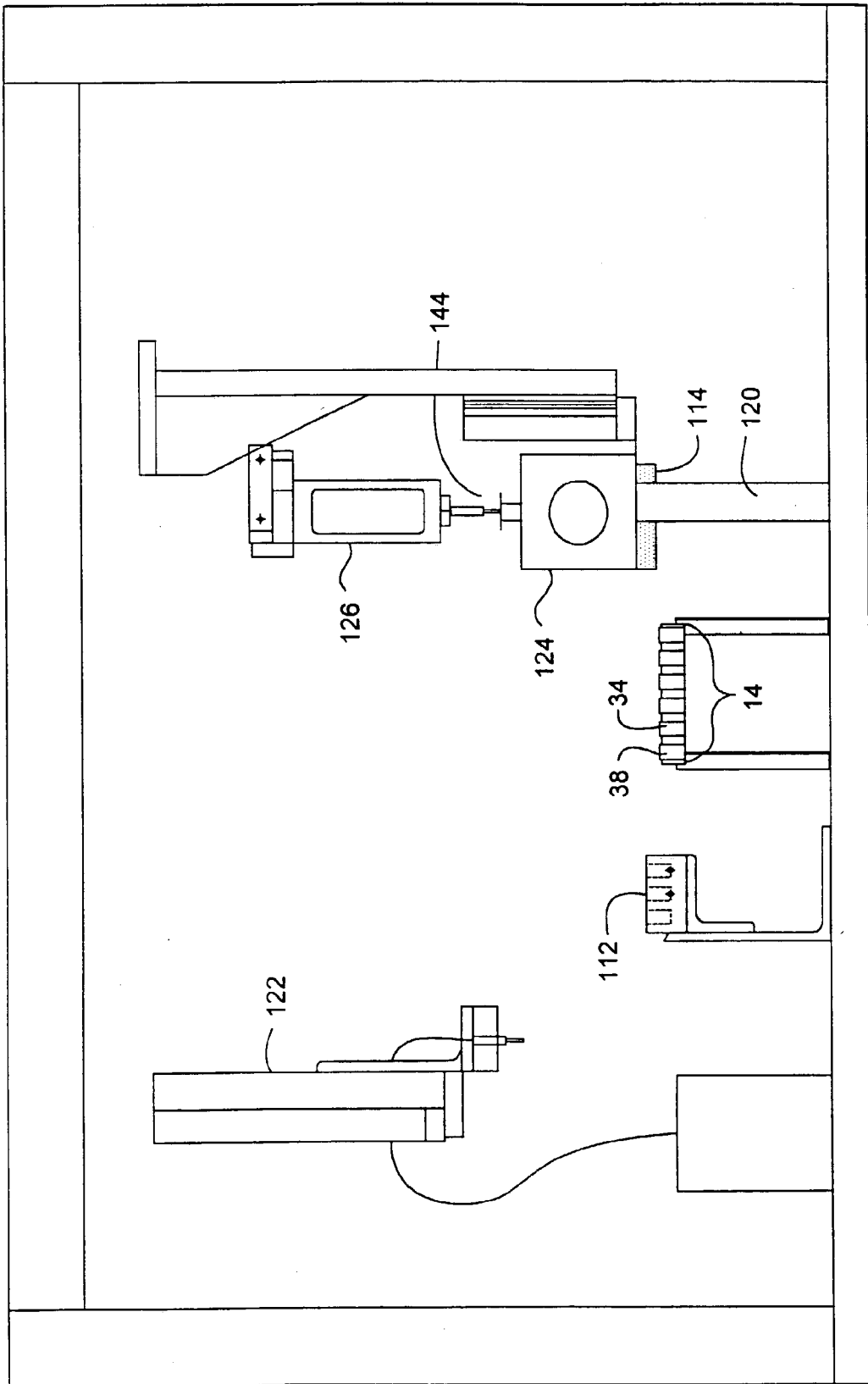

FIG. 6E

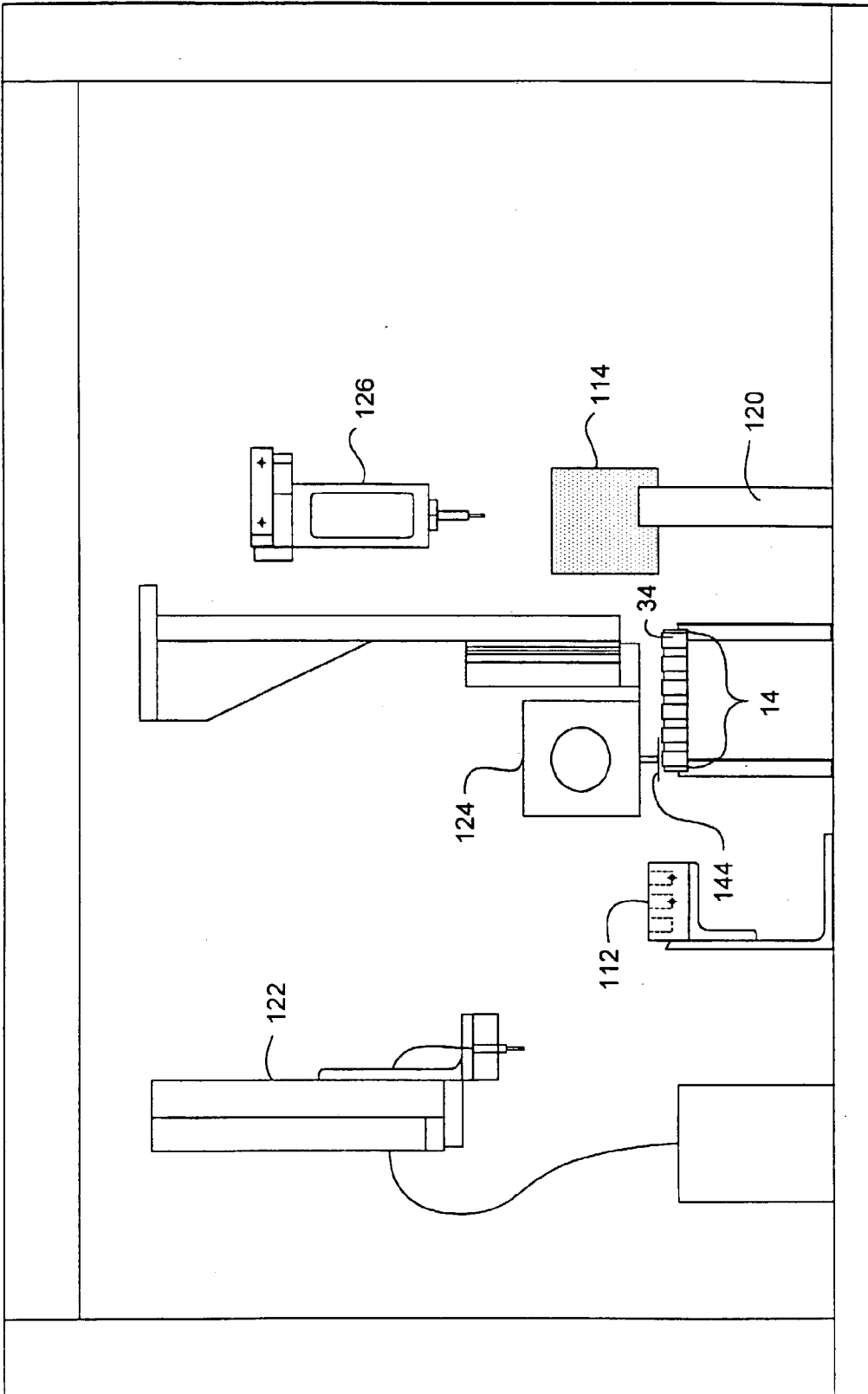

FIG. 6F

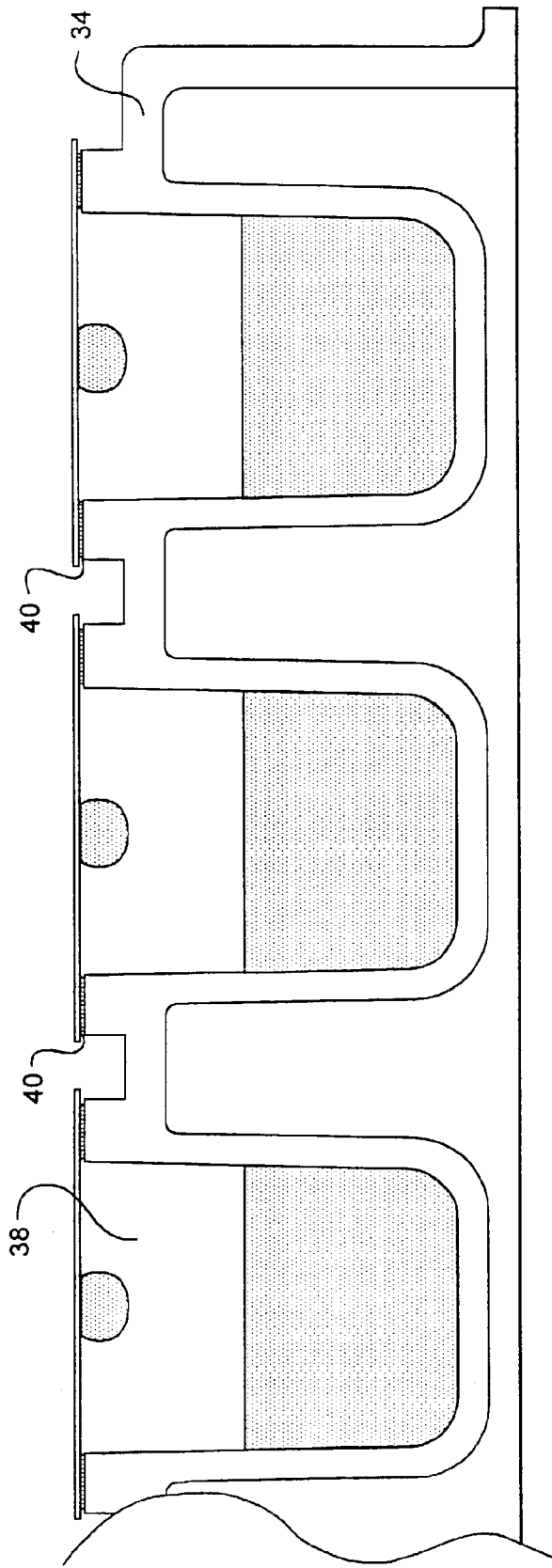

FIG. 6G

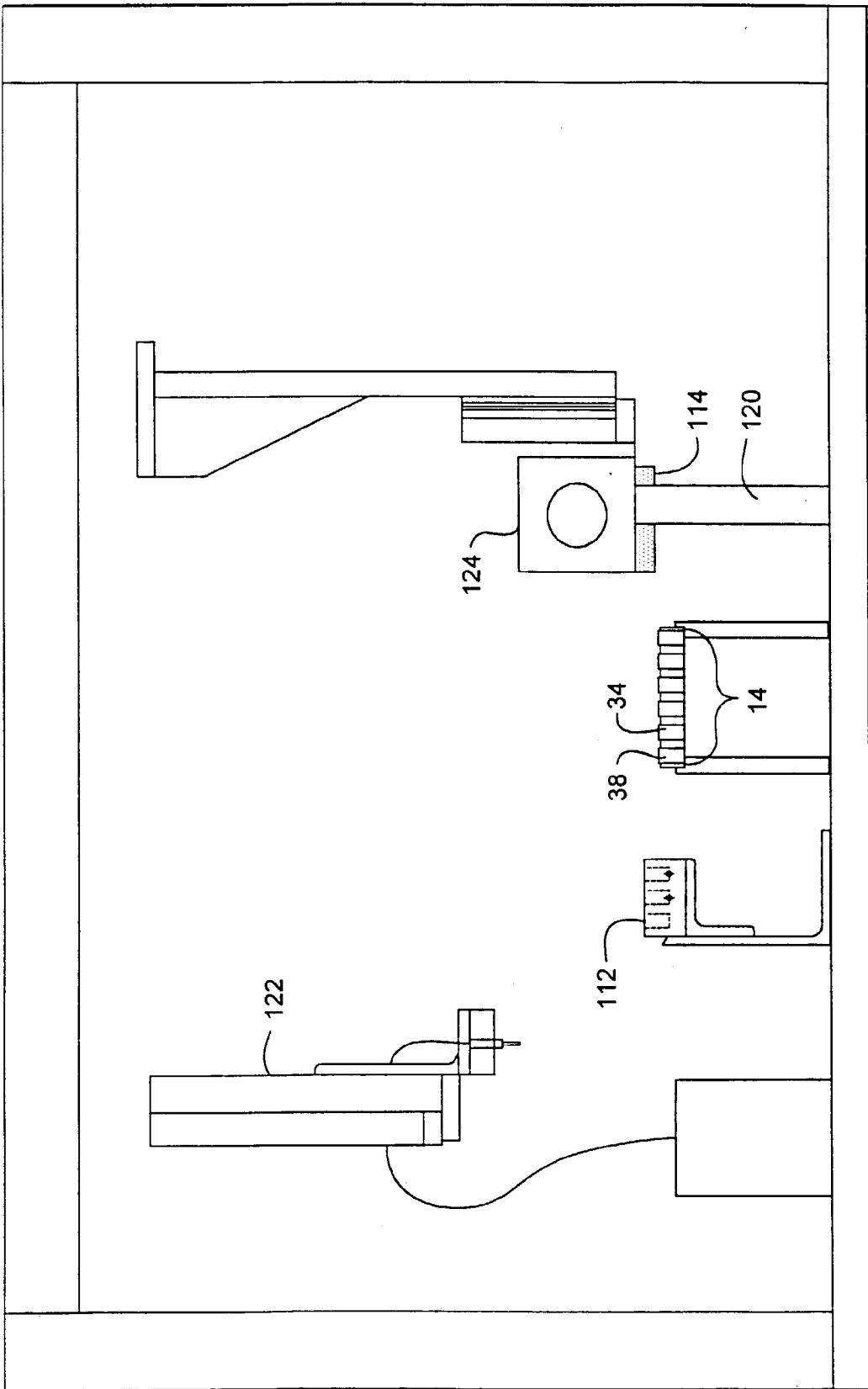

FIG. 6H

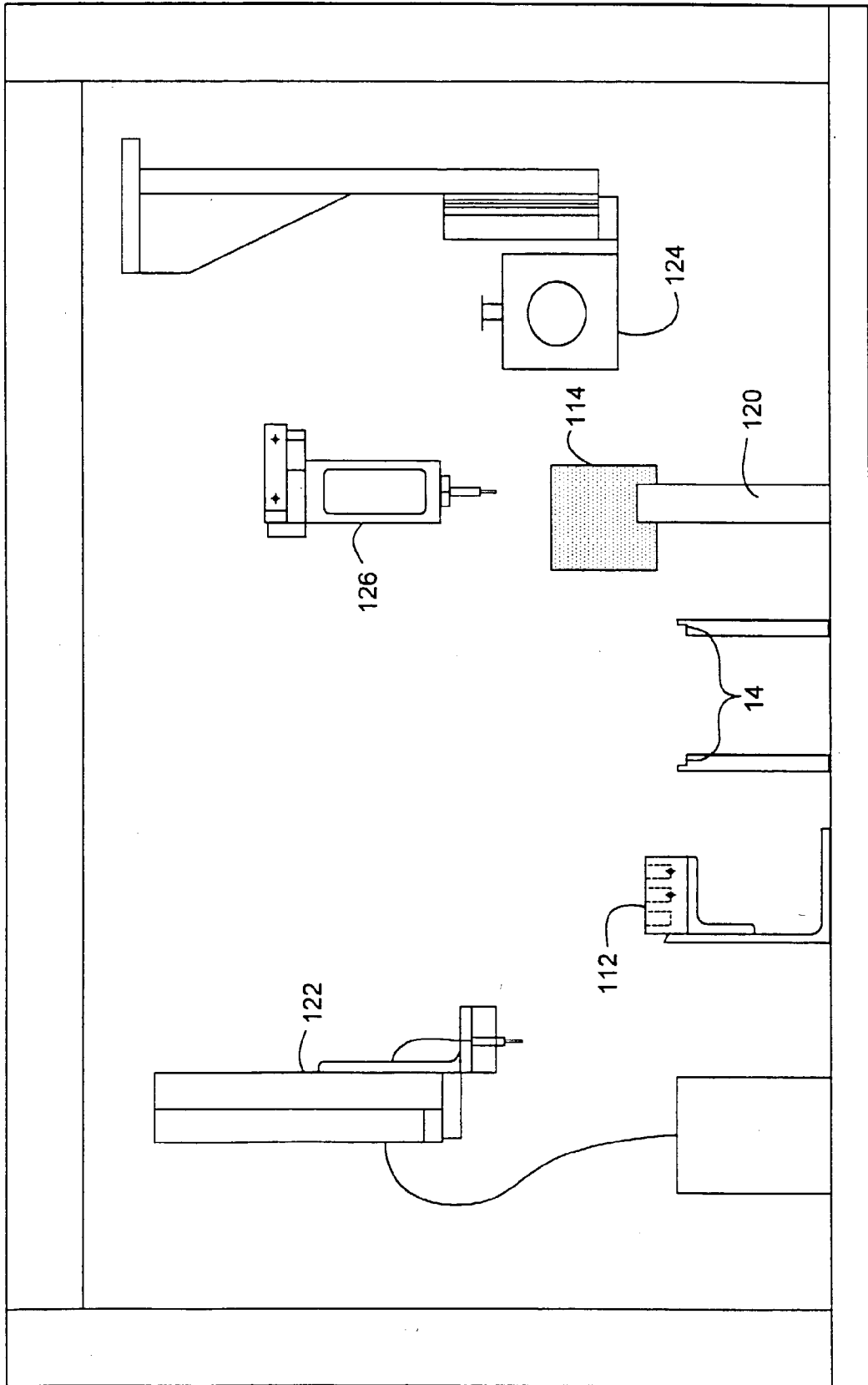

FIG. 6I

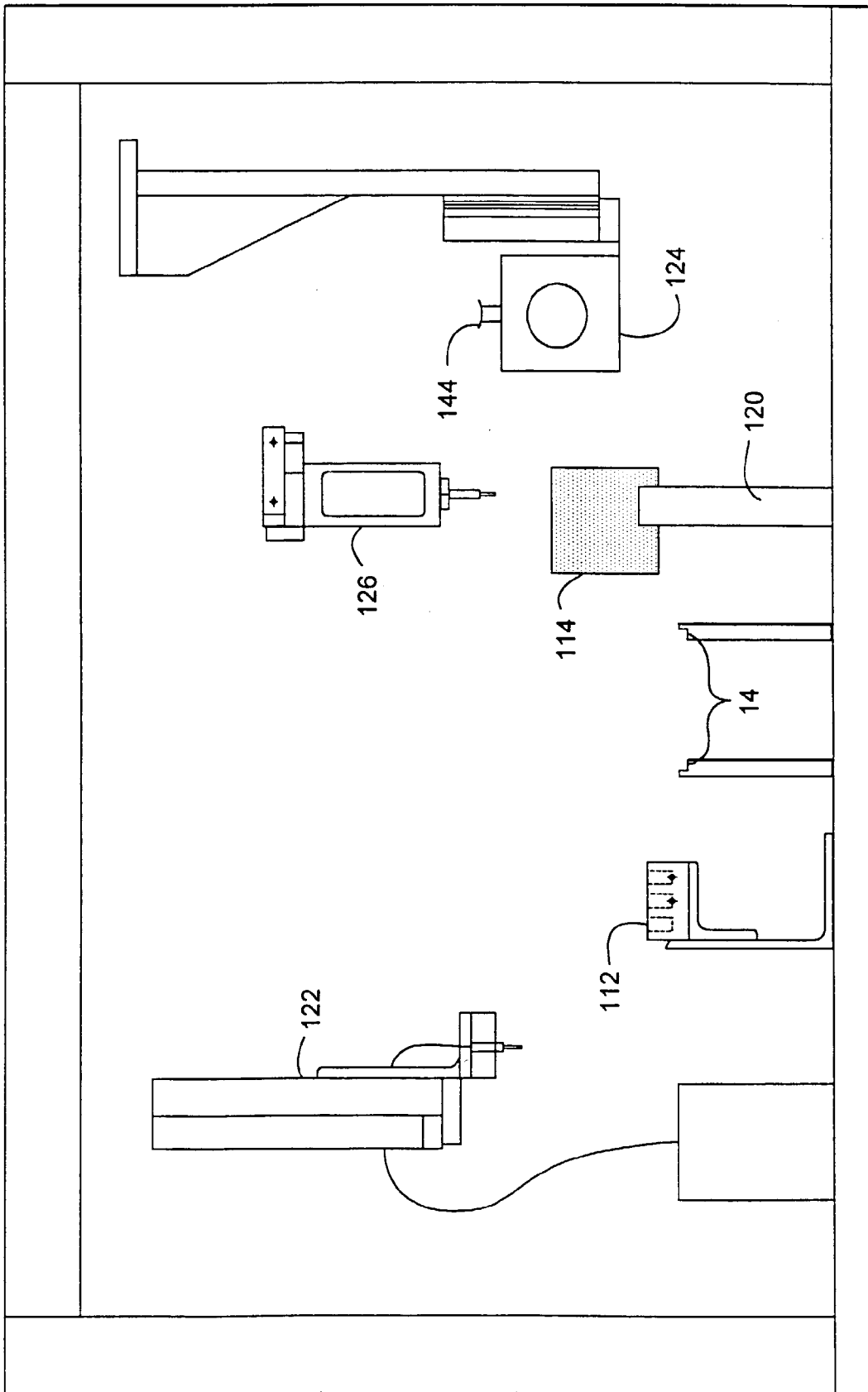

FIG. 7A

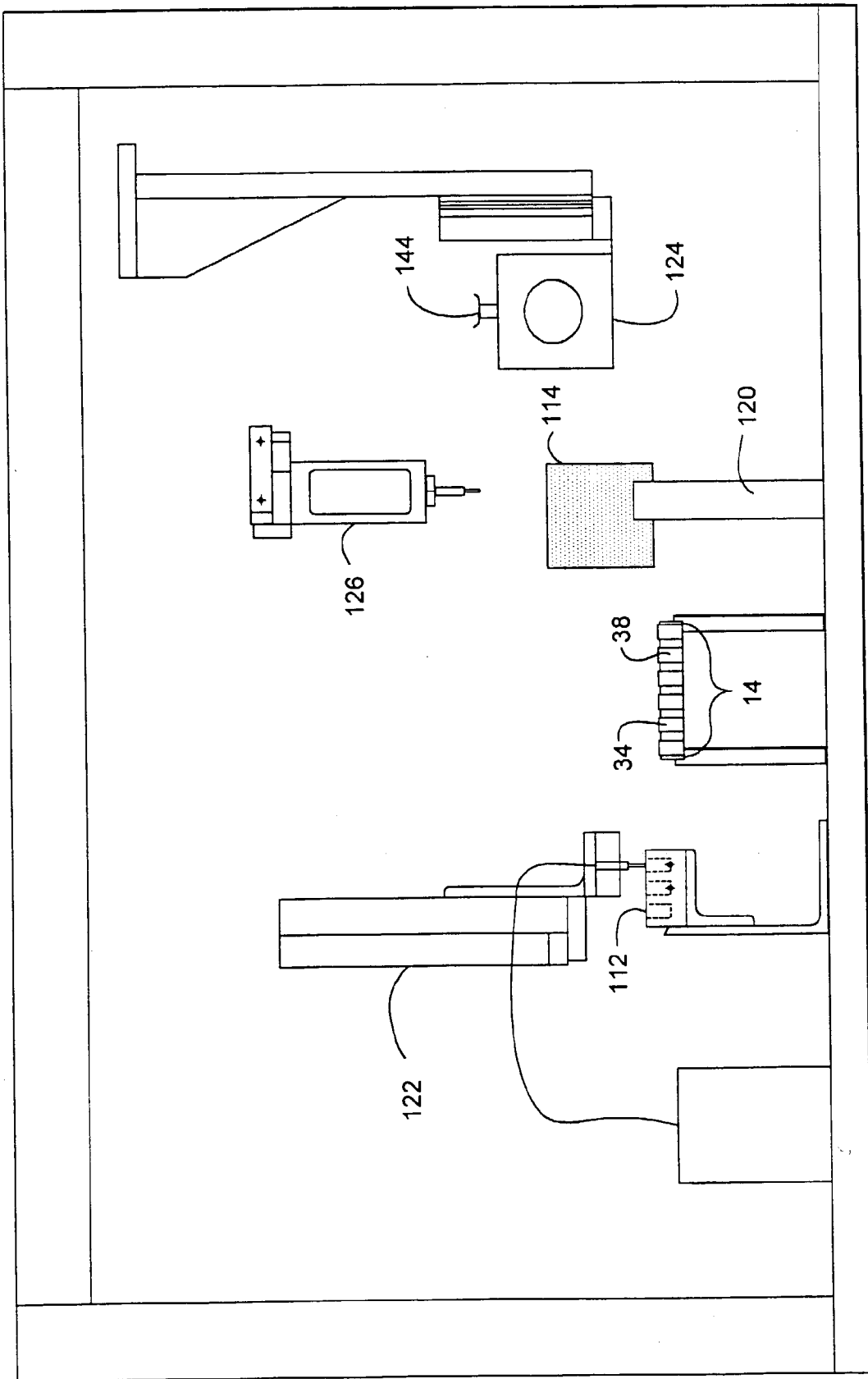

FIG. 7B

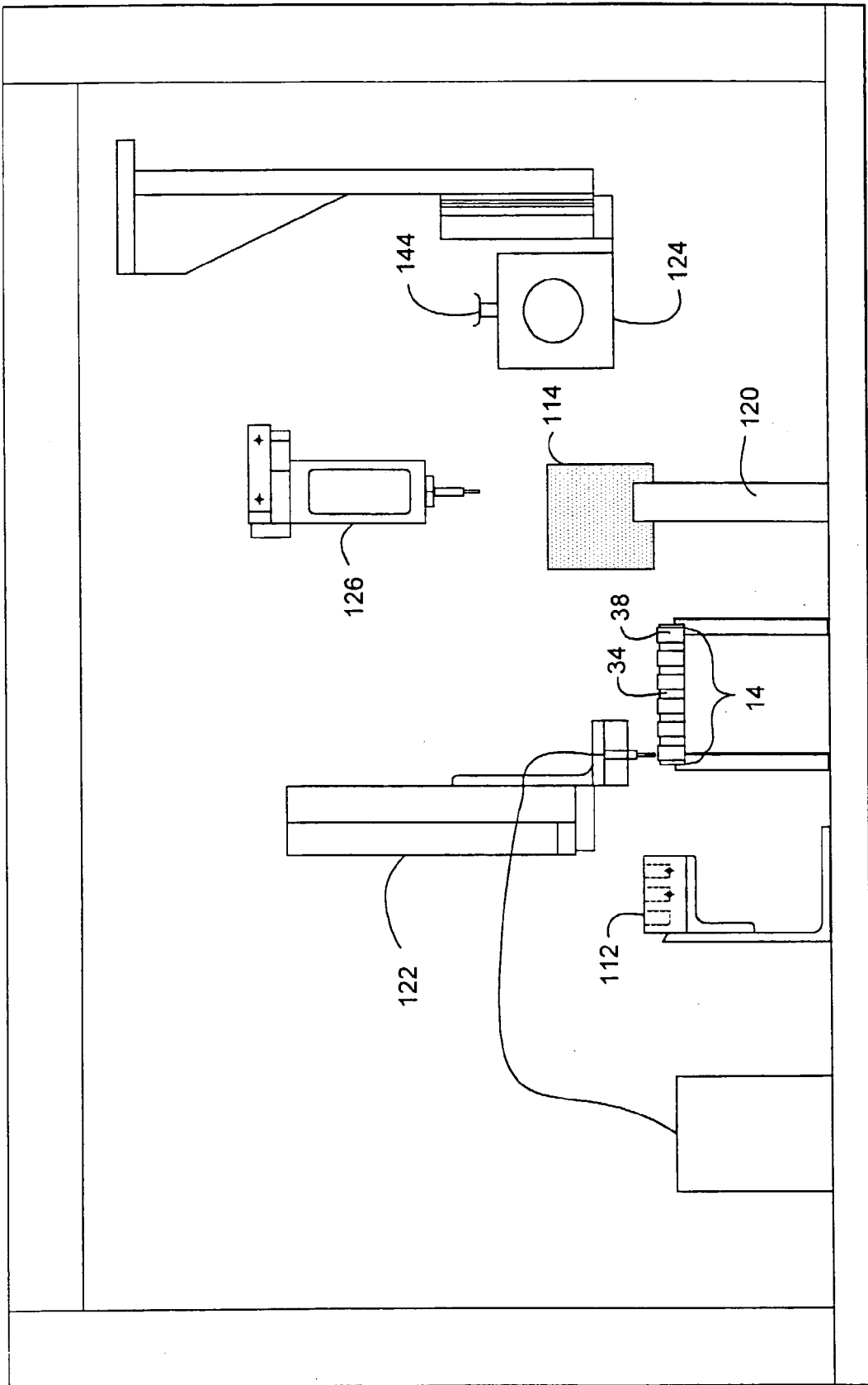

FIG. 7C



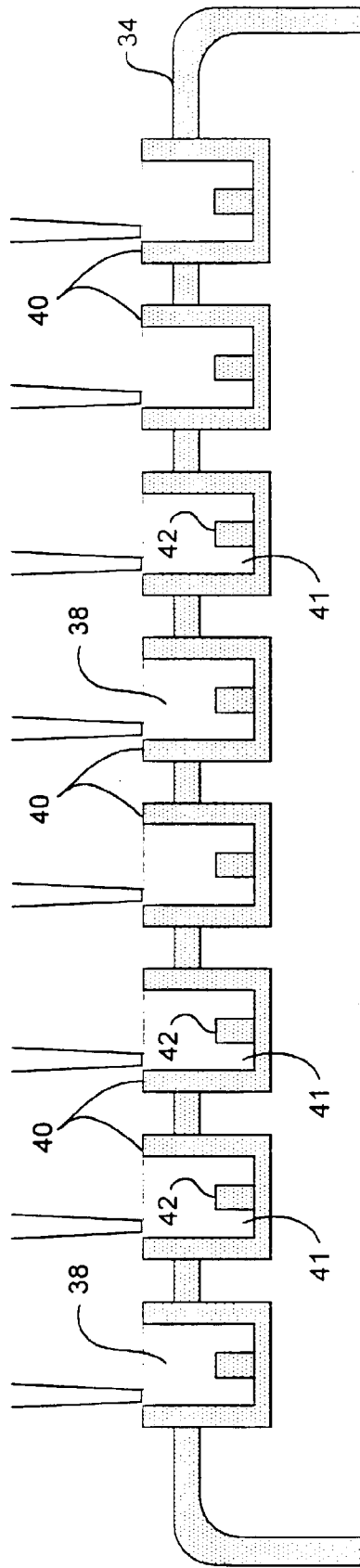

FIG. 7D

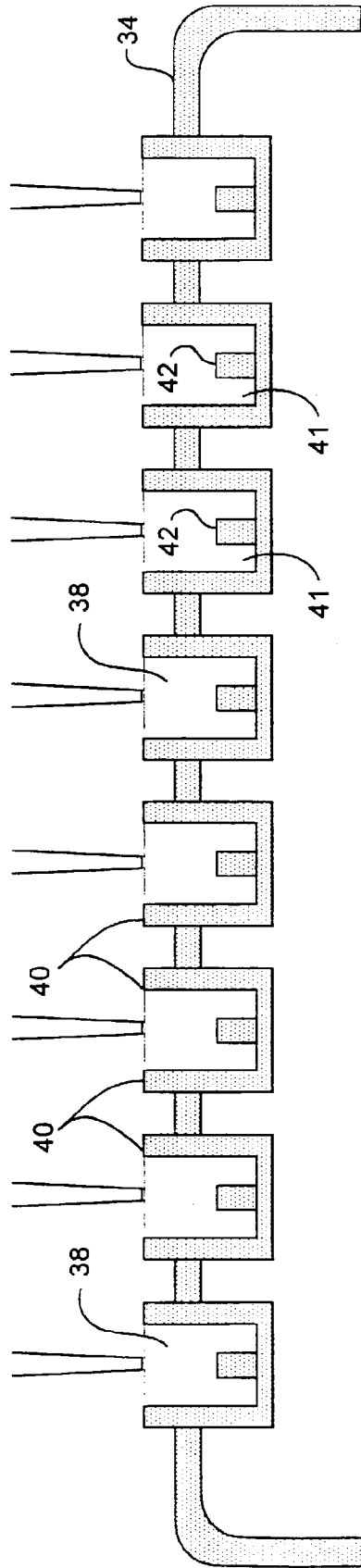

FIG. 7E

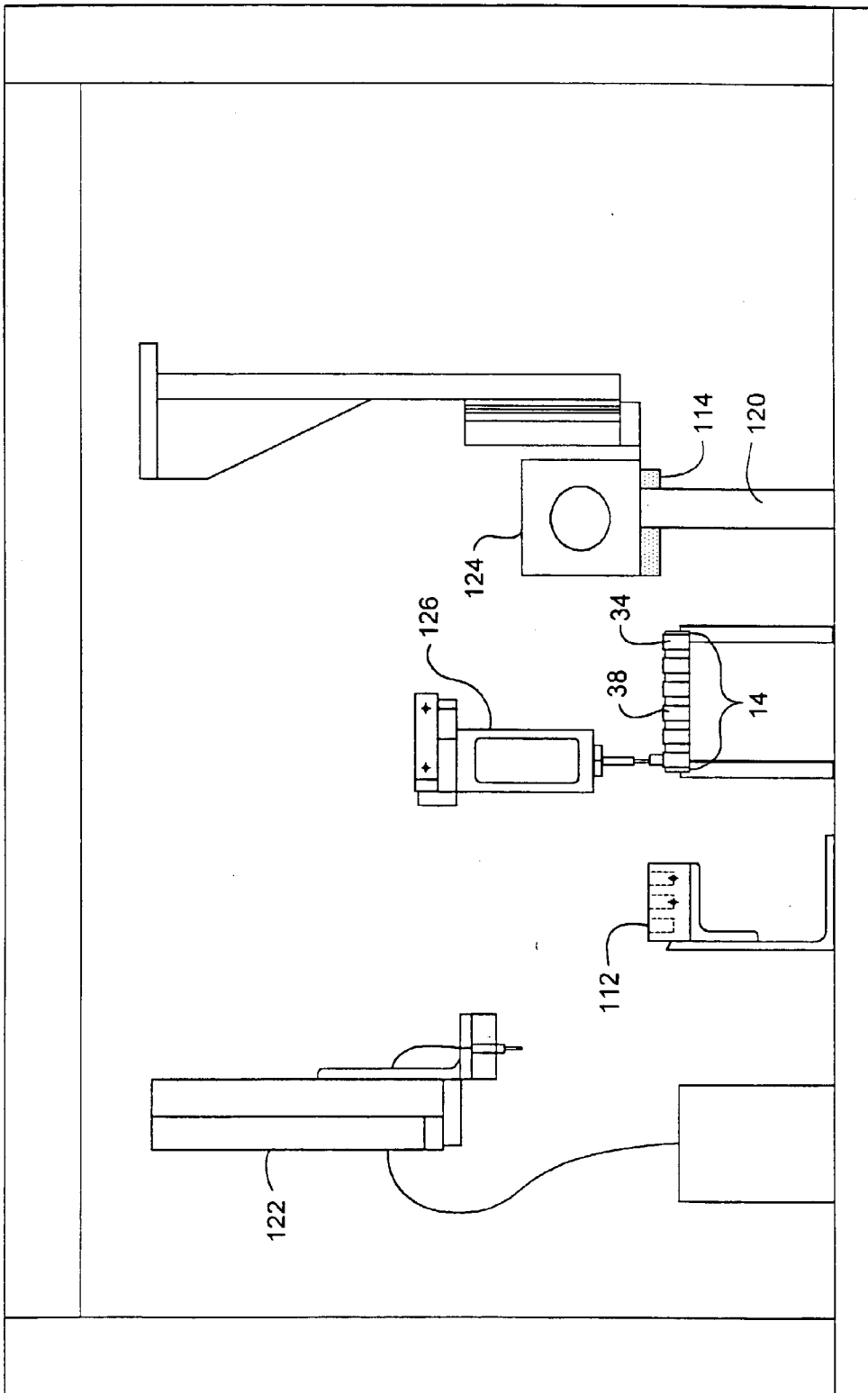

FIG. 7F

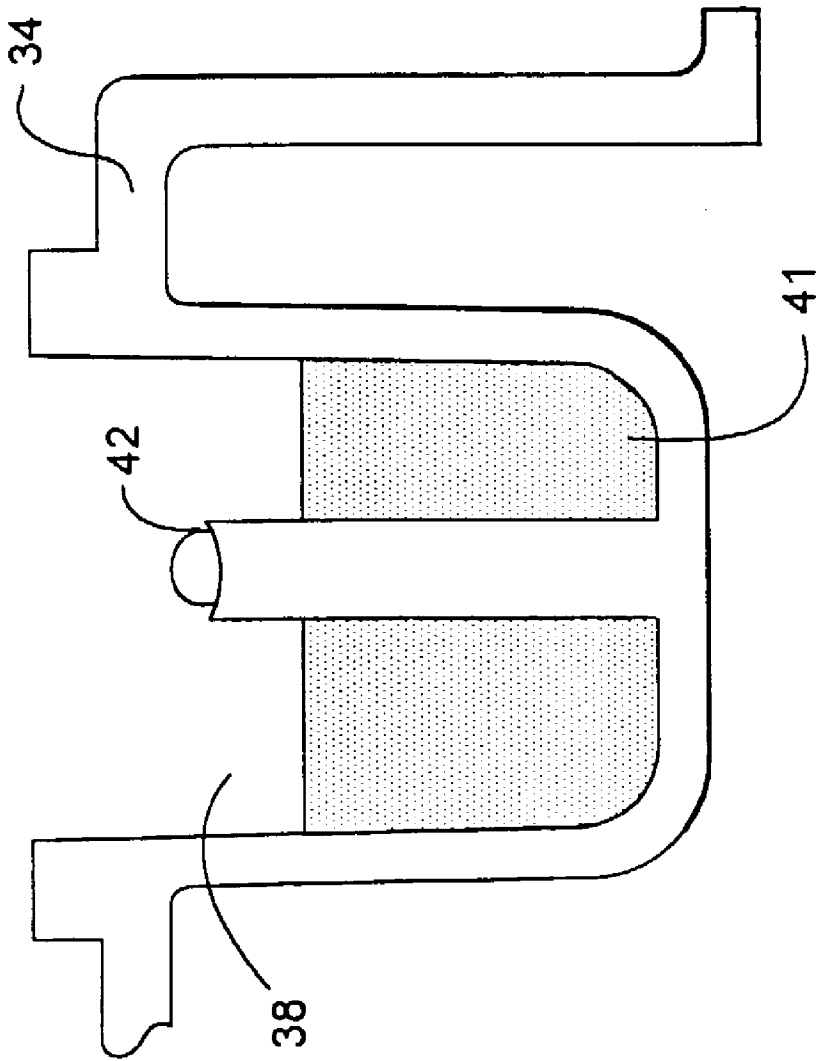

FIG. 7G

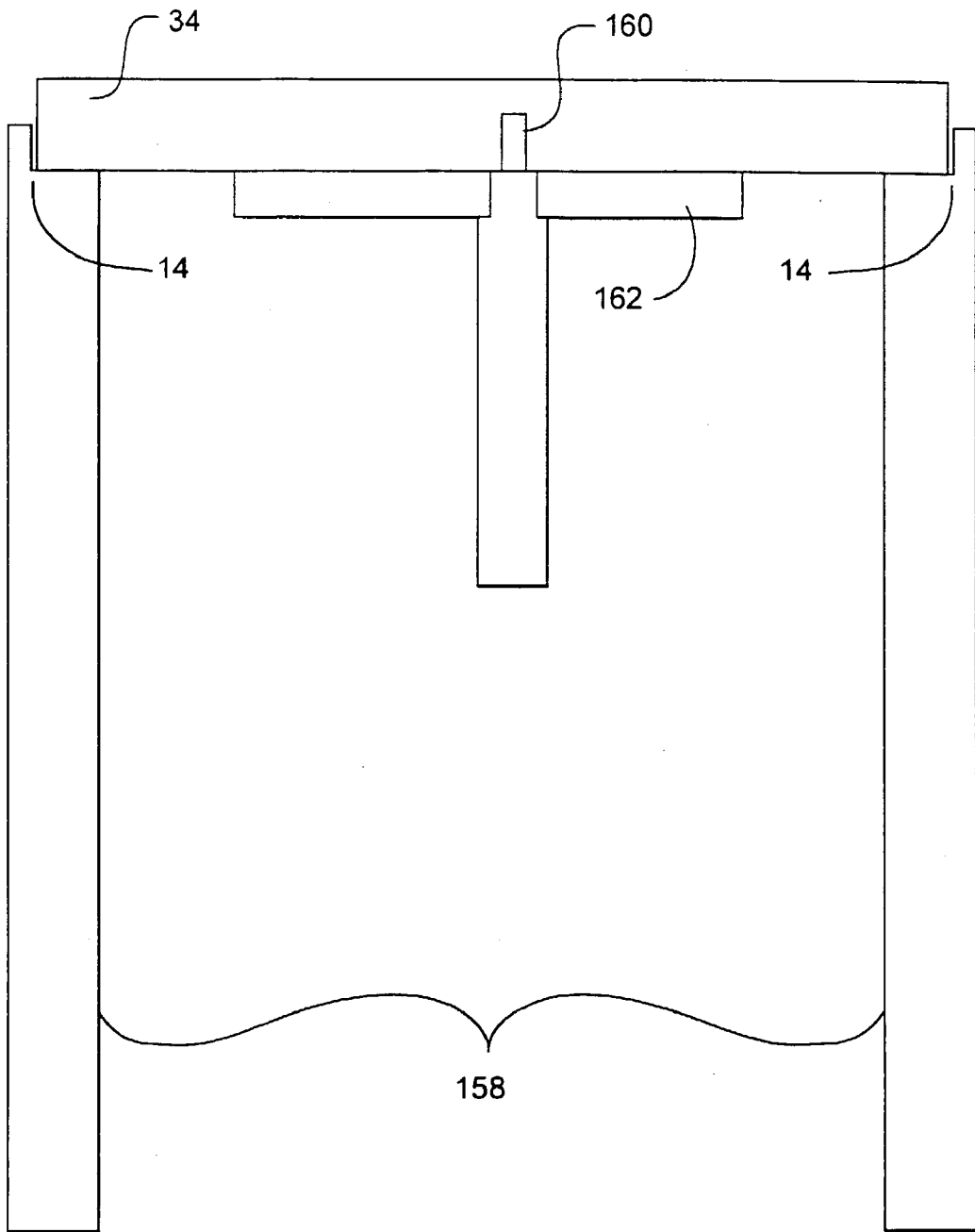

FIG. 8A

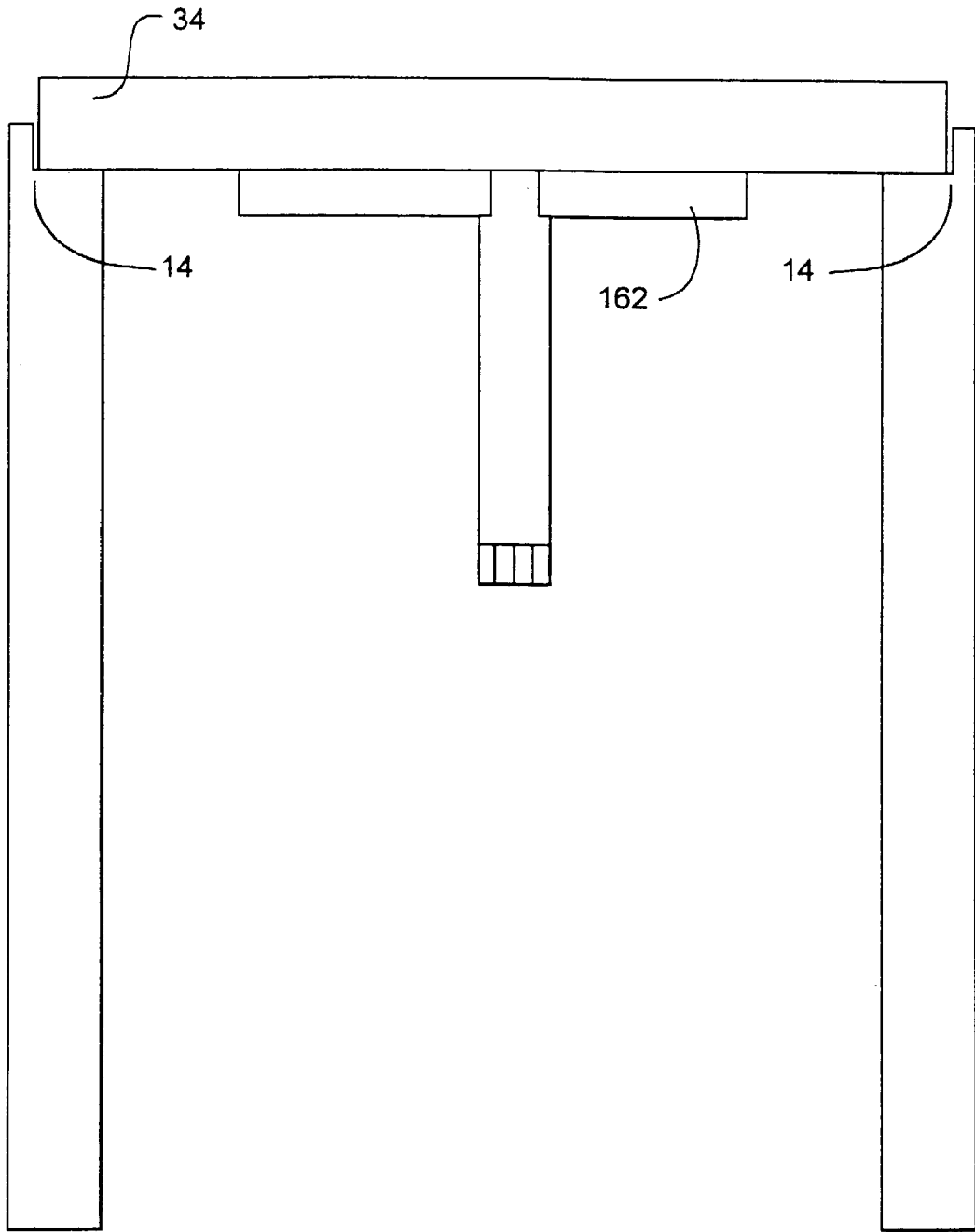

FIG. 8B



## Quik Screen Reagent Formulations

- A1. 0.8 M Sodium/Potassium Phosphate pH 5.0
- B1. 1.0 M Sodium/Potassium Phosphate pH 5.0
- C1. 1.4 M Sodium/Potassium Phosphate pH 5.0
- D1. 1.8 M Sodium/Potassium Phosphate pH 5.0
- A2. 0.8 M Sodium/Potassium Phosphate pH 5.6
- B2. 1.0 M Sodium/Potassium Phosphate pH 5.6
- C2. 1.4 M Sodium/Potassium Phosphate pH 5.6
- D2. 1.8 M Sodium/Potassium Phosphate pH 5.6
- A3. 0.8 M Sodium/Potassium Phosphate pH 6.3
- B3. 1.0 M Sodium/Potassium Phosphate pH 6.3
- C3. 1.4 M Sodium/Potassium Phosphate pH 6.3
- D3. 1.8 M Sodium/Potassium Phosphate pH 6.3
- A4. 0.8 M Sodium/Potassium Phosphate pH 6.9
- B4. 1.0 M Sodium/Potassium Phosphate pH 6.9
- C4. 1.4 M Sodium/Potassium Phosphate pH 6.9
- D4. 1.8 M Sodium/Potassium Phosphate pH 6.9
- A5. 0.8 M Sodium/Potassium Phosphate pH 7.5
- B5. 1.0 M Sodium/Potassium Phosphate pH 7.5
- C5. 1.4 M Sodium/Potassium Phosphate pH 7.5
- D5. 1.8 M Sodium/Potassium Phosphate pH 7.5
- A6. 0.8 M Sodium/Potassium Phosphate pH 8.2
- B6. 1.0 M Sodium/Potassium Phosphate pH 8.2
- C6. 1.4 M Sodium/Potassium Phosphate pH 8.2
- D6. 1.8 M Sodium/Potassium Phosphate pH 8.2

FIG. 9



## Detergent Screen 2 Reagent Formulations

1. 10% v/v Pluronic F-68
2. 10% v/v Anapoe 35
3. 10% v/v Anapoe 56
4. 10% v/v Anapoe 58
5. 10% v/v Anapoe X-114
6. 10% v/v Anapoe X-305
7. 10% v/v Anapoe X-405
8. 10% v/v Anapoe 20
9. 10% v/v Anapoe 80
10. 10% v/v Anapoe C<sub>10</sub>E<sub>6</sub>
11. 10% v/v Anapoe C<sub>10</sub>E<sub>9</sub>
12. 10% v/v Anapoe C<sub>12</sub>E<sub>10</sub>
13. 10% v/v Anapoe C<sub>13</sub>E<sub>6</sub>
14. 10% w/v IPTG
15. 1.5 mM n-Dodecyl-N,N-dimethylglycine
16. 7.0 mM HEGA-10
17. 7.1 mM C<sub>8</sub>E<sub>5</sub>
18. 8.0 mM CHAPS
19. 8.0 mM CHAPSO
20. 11.5 mM C-HEGA 11
21. 39 mM HEGA-9
22. 108 mM C-HEGA 9
23. 109 mM HEGA-8
24. 277 mM C-HEGA-8

Note: [mM] is that of the CMC of the detergent

FIG. 9  
(Continued)

## Detergent Screen 3 Reagent Formulations

1. 10% w/v BAM
  2. 0.006 mM n-Hexadecyl-b-D-maltoside
  3. 0.1 mM n-Tetradecyl-b-D-maltoside
  4. 0.33 mM n-Tridecyl-b-D-maltoside
  5. 0.9 mM Thesit
  6. 4.0 mM Zwittergent 3-14
  7. 5.9 mM n- Undecyl-b-D-maltoside
  8. 9.0 mM n-Decyl-b-D-thiomaltoside
  9. 15.0 mM FOS-Choline 12
  10. 25 mM n-Decanoylsucrose
  11. 29.0 mM l-S-Nonyl-b-D-thioglucoside
  12. 32.0 mM n-Nonyl-b-D-thiomaltoside
  13. 43.0 mM DDMAB
  14. 60.0 mM n-Nonyl-b-D-maltoside
  15. 76.0 mM Cymal-4
  16. ◇
- 

17. 130 mM FOS-Choline-10
18. 190 mM FOS-Choline-9
19. 250 mM MEGA-9
20. 290 mM l-S-Heptyl-b-D-thioglucoside
21. 1.02 M FOS-Choline-8
22. 1.20 M Cymal-2
23. 3.30 M Zwittergent 3-08
24. 3.40 M Cymal-1

**Note:** [mM] is that of the CMC of the detergent

**FIG. 9**  
(Continued)

## Crystal Screen Reagent Formulations

1. 30% MPD, 0.1 M Na Acetate pH 4.6, 0.02 M Calcium Chloride
2. 0.4 M K, Na Tartrate
3. 0.4 M Ammonium Phosphate
4. 2.0 Ammonium Sulfate, 0.1 M Tris HCl pH 8.5
5. 30% MPD, 0.1 M Na HEPES pH 7.5, 0.2 M Na Citrate
6. 30% PEG 4000, 0.1 M Tris HCl pH 8.5, 0.2 M Mg Chloride
7. 1.4 M Na Acetate, 0.1 M Na Cacodylate pH 6.5
8. 30% 2-Propanol, 0.1 M Na Cacodylate pH 6.5, 0.2 M Na Citrate
9. 30% PEG 4000, 0.1 M Na Citrate pH 5.6, 0.2 Ammonium Acetate
10. 30% PEG 4000, 0.1 M Na Acetate pH 4.6, 0.2 M Ammonium Acetate
11. 1.0 M Ammonium Phosphate, 0.1 M Na Citrate pH 5.6
12. 30% 2-Propanol, 0.1 M Na HEPES pH 7.5, 0.2 M Mg Chloride
13. 30% PEG 400, 0.1 M Tris HCl pH 8.5, 0.2 M Na Citrate
14. 28% PEG 400, 0.1 M Na HEPES pH 7.5, 0.2 M Ca Chloride
15. 30% PEG 8000, 0.1 M Na Cacodylate pH 6.5, 0.2 M Ammonium Sulfate
16. 1.5 M Li Sulfate, 0.1 M Na HEPES pH 7.5
17. 30% PEG 4000, 0.1 M Tris HCl pH 8.5, 0.2 M Li Sulfate
18. 20% PEG 8000, 0.1 M NA Cacodylate pH 6.5, 0.2 M Mg Acetate
19. 30% 2-Propanol, 0.1 M Tris HCl pH 8.5, 0.2 M Ammonium Acetate
20. 25% PEG 4000, 0.1 M Na Acetate pH 4.6, 0.2 M Ammonium Sulfate
21. 30% MPD, 0.1 M Na Cacodylate pH 6.5, 0.2 M Mg Acetate
22. 30% PEG 4000, 0.1 M Tris HCl pH 8.5, 0.2 M Na Acetate
23. 30% PEG 400, 0.1 M Na HEPES pH 7.5, 0.2 M Mg Chloride
24. 20% 2-Propanol, 0.1 M Na Acetate pH 4.6, 0.2 M Ca Chloride

**FIG. 9**  
(Continued)

## Crystal Screen Reagent Formulations

25. 1.0 M Na Acetate, 0.1 M Imidazole pH 6.5
26. 30% MPD, 0.1 M Na Citrate pH 5.6, 0.2 M Ammonium Acetate
27. 20% 2-Propanol, 0.1 M Na HEPES pH 7.5, 0.2 M Na Citrate
28. 30% PEG 8000, 0.1 M Na Cacodylate pH 6.5, 0.2 M Na Acetate
29. 0.8 M K<sub>2</sub>Na Tartrate, 0.1 M Na HEPES pH 7.5
30. 30% PEG 8000, 0.2 M Ammonium Sulfate
31. 30% PEG 4000, 0.2 M Ammonium Sulfate
32. 2.0 M Ammonium Sulfate
33. 4.0 M Na Formate
34. 2.0 M Na Formate, 0.1 M Na Acetate pH 4.6
35. 1.6 M Na<sub>2</sub>K Phosphate, 0.1 M Na HEPES pH 7.5
36. 8% PEG 8000, 0.1 M Tris HCl pH 8.5
37. 8% PEG 4000, 0.1 M Na Acetate pH 4.6
38. 1.4 M Na Citrate, 0.1 M Na HEPES pH 7.5
39. 2% PEG 400, 2.0 M Ammonium Sulfate, 0.1 M Na HEPES pH 7.5
40. 20% 2-Propanol, 20% PEG 4000, 0.1 M Na Citrate pH 5.6
41. 10% 2-Propanol, 20% PEG 4000, 0.1 M Na HEPES pH 7.5
42. 20% PEG 8000, 0.05 M K Phosphate
43. 30% PEG 1500
44. 0.2 M Mg Formate
45. 18% PEG 8000, 0.1 M Na Cacodylate pH 6.5, 0.2 M Zn Acetate
46. 18% PEG 8000, 0.1 M Na Cacodylate pH 6.5, 0.2 M Ca Acetate
47. 2.0 M Ammonium Sulfate, 0.1 M Na Acetate pH 4.6
48. 2.0 M Ammonium Phosphate, 0.1 M Tris HCl pH 8.5

**FIG. 9**  
(Continued)

## Grid Screen Ammonium Sulfate Reagent Formulations

- A1.** 0.1 M Citric Acid pH 4.0, 0.8 M Ammonium Sulfate
- B1.** 0.1 M Citric Acid pH 4.0, 1.6 M Ammonium Sulfate
- C1.** 0.1 M Citric Acid pH 4.0, 2.4 M Ammonium Sulfate
- D1.** 0.1 M Citric Acid pH 4.0, 3.2 M Ammonium Sulfate
- A2.** 0.1 M Citric Acid pH 5.0, 0.8 M Ammonium Sulfate
- B2.** 0.1 M Citric Acid pH 5.0, 1.6 M Ammonium Sulfate
- C2.** 0.1 M Citric Acid pH 5.0, 2.4 M Ammonium Sulfate
- D2.** 0.1 M Citric Acid pH 5.0, 3.2 M Ammonium Sulfate
- A3.** 0.1 M MES pH 6.0, 0.8 M Ammonium Sulfate
- B3.** 0.1 M MES pH 6.0, 1.6 M Ammonium Sulfate
- C3.** 0.1 M MES pH 6.0, 2.4 M Ammonium Sulfate
- D3.** 0.1 M MES pH 6.0, 3.2 M Ammonium Sulfate
- A4.** 0.1 M HEPES pH 7.0, 0.8 M Ammonium Sulfate
- B4.** 0.1 M HEPES pH 7.0, 1.6 M Ammonium Sulfate
- C4.** 0.1 M HEPES pH 7.0, 2.4 M Ammonium Sulfate
- D4.** 0.1 M HEPES pH 7.0, 3.2 M Ammonium Sulfate
- A5.** 0.1 M Tris pH 8.0, 0.8 M Ammonium Sulfate
- B5.** 0.1 M Tris pH 8.0, 1.6 M Ammonium Sulfate
- C5.** 0.1 M Tris pH 8.0, 2.4 M Ammonium Sulfate
- D5.** 0.1 M Tris pH 8.0, 3.2 M Ammonium Sulfate
- A6.** 0.1 M Bicine pH 9.0, 0.8 M Ammonium Sulfate
- B6.** 0.1 M Bicine pH 9.0, 1.6 M Ammonium Sulfate
- C6.** 0.1 M Bicine pH 9.0, 2.4 M Ammonium Sulfate
- D6.** 0.1 M Bicine pH 9.0, 3.2 M Ammonium Sulfate

**FIG. 9**  
(Continued)

## Grid Screen MPD Reagent Formulations

- A1.** 0.1 M Citric Acid pH 4.0, 10% 2-Methyl-2,4-pentanediol
- B1.** 0.1 M Citric Acid pH 4.0, 20% 2-Methyl-2,4-pentanediol
- C1.** 0.1 M Citric Acid pH 4.0, 40% 2-Methyl-2,4-pentanediol
- D1.** 0.1 M Citric Acid pH 4.0, 65% 2-Methyl-2,4-pentanediol
- A2.** 0.1 M Sodium Acetate trihydrate pH 5.0, 10% 2-Methyl-2,4-pentanediol
- B2.** 0.1 M Sodium Acetate trihydrate pH 5.0, 20% 2-Methyl-2,4-pentanediol
- C2.** 0.1 M Sodium Acetate trihydrate pH 5.0, 40% 2-Methyl-2,4-pentanediol
- D2.** 0.1 M Sodium Acetate trihydrate pH 5.0, 65% 2-Methyl-2,4-pentanediol
- A3.** 0.1 M MES pH 6.0, 10% 2-Methyl-2,4-pentanediol
- B3.** 0.1 M MES pH 6.0, 20% 2-Methyl-2,4-pentanediol
- C3.** 0.1 M MES pH 6.0, 40% 2-Methyl-2,4-pentanediol
- D3.** 0.1 M MES pH 6.0, 65% 2-Methyl-2,4-pentanediol
- A4.** 0.1 M HEPES pH 7.0, 10% 2-Methyl-2,4-pentanediol
- B4.** 0.1 M HEPES pH 7.0, 20% 2-Methyl-2,4-pentanediol
- C4.** 0.1 M HEPES pH 7.0, 40% 2-Methyl-2,4-pentanediol
- D4.** 0.1 M HEPES pH 7.0, 65% 2-Methyl-2,4-pentanediol
- A5.** 0.1 M Tris pH 8.0, 10% 2-Methyl-2,4-pentanediol
- B5.** 0.1 M Tris pH 8.0, 20% 2-Methyl-2,4-pentanediol
- C5.** 0.1 M Tris pH 8.0, 40% 2-Methyl-2,4-pentanediol
- D5.** 0.1 M Tris pH 8.0, 65% 2-Methyl-2,4-pentanediol
- A6.** 0.1 M Bicine pH 9.0, 10% 2-Methyl-2,4-pentanediol
- B6.** 0.1 M Bicine pH 9.0, 20% 2-Methyl-2,4-pentanediol
- C6.** 0.1 M Bicine pH 9.0, 40% 2-Methyl-2,4-pentanediol
- D6.** 0.1 M Bicine pH 9.0, 65% 2-Methyl-2,4-pentanediol

**FIG. 9**  
(Continued)

## Grid Screen Sodium Chloride Reagent Formulations

- A1.** 0.1 M Citric Acid pH 4.0, 1.0 M Sodium Chloride
- B1.** 0.1 M Citric Acid pH 4.0, 2.0 M Sodium Chloride
- C1.** 0.1 M Citric Acid pH 4.0, 3.0 M Sodium Chloride
- D1.** 0.1 M Citric Acid pH 4.0, 4.0 M Sodium Chloride
- A2.** 0.1 M Citric Acid pH 5.0, 1.0 M Sodium Chloride
- B2.** 0.1 M Citric Acid pH 5.0, 2.0 M Sodium Chloride
- C2.** 0.1 M Citric Acid pH 5.0, 3.0 M Sodium Chloride
- D2.** 0.1 M Citric Acid pH 5.0, 4.0 M Sodium Chloride
- A3.** 0.1 M MES pH 6.0, 1.0 M Sodium Chloride
- B3.** 0.1 M MES pH 6.0, 2.0 M Sodium Chloride
- C3.** 0.1 M MES pH 6.0, 3.0 M Sodium Chloride
- D3.** 0.1 M MES pH 6.0, 4.0 M Sodium Chloride
- A4.** 0.1 M HEPES pH 7.0, 1.0 M Sodium Chloride
- B4.** 0.1 M HEPES pH 7.0, 2.0 M Sodium Chloride
- C4.** 0.1 M HEPES pH 7.0, 3.0 M Sodium Chloride
- D4.** 0.1 M HEPES pH 7.0, 4.0 M Sodium Chloride
- A5.** 0.1 M Tris pH 8.0, 1.0 M Sodium Chloride
- B5.** 0.1 M Tris pH 8.0, 2.0 M Sodium Chloride
- C5.** 0.1 M Tris pH 8.0, 3.0 M Sodium Chloride
- D5.** 0.1 M Tris pH 8.0, 4.0 M Sodium Chloride
- A6.** 0.1 M Bicine pH 9.0, 1.0 M Sodium Chloride
- B6.** 0.1 M Bicine pH 9.0, 2.0 M Sodium Chloride
- C6.** 0.1 M Bicine pH 9.0, 3.0 M Sodium Chloride
- D6.** 0.1 M Bicine pH 9.0, 4.0 M Sodium Chloride

**FIG. 9**  
(Continued)

## Grid Screen PEG 6000 Reagent Formulations

- A1.** 0.1 M Citric Acid pH 4.0, 5% Polyethylene Glycol 6000
- B1.** 0.1 M Citric Acid pH 4.0, 10% Polyethylene Glycol 6000
- C1.** 0.1 M Citric Acid pH 4.0, 20% Polyethylene Glycol 6000
- D1.** 0.1 M Citric Acid pH 4.0, 30% Polyethylene Glycol 6000
- A2.** 0.1 M Citric Acid pH 5.0, 5% Polyethylene Glycol 6000
- B2.** 0.1 M Citric Acid pH 5.0, 10% Polyethylene Glycol 6000
- C2.** 0.1 M Citric Acid pH 5.0, 20% Polyethylene Glycol 6000
- D2.** 0.1 M Citric Acid pH 5.0, 30% Polyethylene Glycol 6000
- A3.** 0.1 M MES pH 6.0, 5% Polyethylene Glycol 6000
- B3.** 0.1 M MES pH 6.0, 10% Polyethylene Glycol 6000
- C3.** 0.1 M MES pH 6.0, 20% Polyethylene Glycol 6000
- D3.** 0.1 M MES pH 6.0, 30% Polyethylene Glycol 6000
- A4.** 0.1 M HEPES pH 7.0, 5% Polyethylene Glycol 6000
- B4.** 0.1 M HEPES pH 7.0, 10% Polyethylene Glycol 6000
- C4.** 0.1 M HEPES pH 7.0, 20% Polyethylene Glycol 6000
- D4.** 0.1 M HEPES pH 7.0, 30% Polyethylene Glycol 6000
- A5.** 0.1 M Tris pH 8.0, 5% Polyethylene Glycol 6000
- B5.** 0.1 M Tris pH 8.0, 10% Polyethylene Glycol 6000
- C5.** 0.1 M Tris pH 8.0, 20% Polyethylene Glycol 6000
- D5.** 0.1 M Tris pH 8.0, 30% Polyethylene Glycol 6000
- A6.** 0.1 M Bicine pH 9.0, 5% Polyethylene Glycol 6000
- B6.** 0.1 M Bicine pH 9.0, 10% Polyethylene Glycol 6000
- C6.** 0.1 M Bicine pH 9.0, 20% Polyethylene Glycol 6000
- D6.** 0.1 M Bicine pH 9.0, 30% Polyethylene Glycol 6000

**FIG. 9**  
(Continued)



## Grid Screen PEG/LiCl Reagent Formulations

- A1.** 0.1 M Citric Acid pH 4.0, 1.0 M Lithium Chloride
- B1.** 0.1 M Citric Acid pH 4.0, 10% Polyethylene Glycol 6000, 1.0 M Lithium Chloride
- C1.** 0.1 M Citric Acid pH 4.0, 20% Polyethylene Glycol 6000, 1.0 M Lithium Chloride
- D1.** 0.1 M Citric Acid pH 4.0, 30% Polyethylene Glycol 6000, 1.0 M Lithium Chloride
- A2.** 0.1 M Citric Acid pH 5.0, 1.0 M Lithium Chloride
- B2.** 0.1 M Citric Acid pH 5.0, 10% Polyethylene Glycol 6000, 1.0 M Lithium Chloride
- C2.** 0.1 M Citric Acid pH 5.0, 20% Polyethylene Glycol 6000, 1.0 M Lithium Chloride
- D2.** 0.1 M Citric Acid pH 5.0, 30% Polyethylene Glycol 6000, 1.0 M Lithium Chloride
- A3.** 0.1 M MES pH 6.0, 1.0 M Lithium Chloride
- B3.** 0.1 M MES pH 6.0, 10% Polyethylene Glycol 6000, 1.0 M Lithium Chloride
- C3.** 0.1 M MES pH 6.0, 20% Polyethylene Glycol 6000, 1.0 M Lithium Chloride
- D3.** 0.1 M MES pH 6.0, 30% Polyethylene Glycol 6000, 1.0 M Lithium Chloride
- A4.** 0.1 M HEPES pH 7.0, 1.0 M Lithium Chloride
- B4.** 0.1 M HEPES pH 7.0, 10% Polyethylene Glycol 6000, 1.0 M Lithium Chloride
- C4.** 0.1 M HEPES pH 7.0, 20% Polyethylene Glycol 6000, 1.0 M Lithium Chloride
- D4.** 0.1 M HEPES pH 7.0, 30% Polyethylene Glycol 6000, 1.0 M Lithium Chloride
- A5.** 0.1 M Tris pH 8.0, 1.0 M Lithium Chloride
- B5.** 0.1 M Tris pH 8.0, 10% Polyethylene Glycol 6000, 1.0 M Lithium Chloride
- C5.** 0.1 M Tris pH 8.0, 20% Polyethylene Glycol 6000, 1.0 M Lithium Chloride
- D5.** 0.1 M Tris pH 8.0, 30% Polyethylene Glycol 6000, 1.0 M Lithium Chloride
- A6.** 0.1 M Bicine pH 9.0, 1.0 M Lithium Chloride
- B6.** 0.1 M Bicine pH 9.0, 10% Polyethylene Glycol 6000, 1.0 M Lithium Chloride
- C6.** 0.1 M Bicine pH 9.0, 20% Polyethylene Glycol 6000, 1.0 M Lithium Chloride
- D6.** 0.1 M Bicine pH 9.0, 30% Polyethylene Glycol 6000, 1.0 M Lithium Chloride

**FIG. 9**  
(Continued)

## PEG/Ion Screen Reagent Formulations

1. 0.2 M Sodium Fluoride, 20% PEG 3350
2. 0.2 M Potassium Fluoride, 20% PEG 3350
3. 0.2 M Ammonium Fluoride, 20% PEG 3350
4. 0.2 M Lithium Chloride, 20% PEG 3350
5. 0.2 M Magnesium Chloride, 20% PEG 3350
6. 0.2 M Sodium Chloride, 20% PEG 3350
7. 0.2 M Calcium Chloride, 20% PEG 3350
8. 0.2 M Potassium Chloride, 20% PEG 3350
9. 0.2 M Ammonium Chloride, 20% PEG 3350
10. 0.2 M Sodium Iodide, 20% PEG 3350
11. 0.2 M Potassium Iodide, 20% PEG 3350
12. 0.2 M Ammonium Iodide, 20% PEG 3350
13. 0.2 M Sodium Thiocyanate, 20% PEG 3350
14. 0.2 M Potassium Thiocyanate, 20% PEG 3350
15. 0.2 M Lithium Nitrate, 20% PEG 3350
16. 0.2 M Magnesium Nitrate, 20% PEG 3350
17. 0.2 M Sodium Nitrate, 20% PEG 3350
18. 0.2 M Potassium Nitrate, 20% PEG 3350
19. 0.2 M Ammonium Nitrate, 20% PEG 3350
20. 0.2 M Magnesium Formate, 20% PEG 3350
21. 0.2 M Sodium Formate, 20% PEG 3350
22. 0.2 M Potassium Formate, 20% PEG 3350
23. 0.2 M Ammonium Formate, 20% PEG 3350
24. 0.2 M Lithium Acetate, 20% PEG 3350

**FIG. 9**  
(Continued)

## PEG/Ion Screen Reagent Formulations

25. 0.2 M Magnesium Acetate, 20% PEG 3350
26. 0.2 M Zinc Acetate, 20% PEG 3350
27. 0.2 M Sodium Acetate, 20% PEG 3350
28. 0.2 M Calcium Acetate, 20% PEG 3350
29. 0.2 M Potassium Acetate, 20% PEG 3350
30. 0.2 M Ammonium Acetate, 20% PEG 3350
31. 0.2 M Lithium Sulfate, 20% PEG 3350
32. 0.2 M Magnesium Sulfate, 20% PEG 3350
33. 0.2 M Sodium Sulfate, 20% PEG 3350
34. 0.2 M Potassium Sulfate, 20% PEG 3350
35. 0.2 M Ammonium Sulfate, 20% PEG 3350
36. 0.2 M di-Sodium Tartrate, 20% PEG 3350
37. 0.2 M Potassium Sodium Tartrate, 20% PEG 3350
38. 0.2 M di-Ammonium Tartrate, 20% PEG 3350
39. 0.2 M Sodium dihydrogen Phosphate, 20% PEG 3350
40. 0.2 M di-Sodium hydrogen Phosphate, 20% PEG 3350
41. 0.2 M Potassium dihydrogen Phosphate, 20% PEG 3350
42. 0.2 M di-Potassium hydrogen Phosphate, 20% PEG 3350
43. 0.2 M Ammonium dihydrogen Phosphate, 20% PEG 3350
44. 0.2 M di-Ammonium hydrogen Phosphate, 20% PEG 3350
45. 0.2 M tri-Lithium Citrate, 20% PEG 3350
46. 0.2 M tri-Sodium Citrate, 20% PEG 3350
47. 0.2 M tri-Potassium Citrate, 20% PEG 3350
48. 0.2 M di-Ammonium hydrogen Citrate, 20% PEG 3350

**FIG. 9**  
(Continued)

## MembFac Reagent Formulations

1. 12% MPD, 0.1 M Na Acetate pH 4.6, 0.1 M Na Chloride
2. 12% PEG 4000, 0.1 M Na Acetate pH 4.6, 0.1 M Zn Acetate
3. 10% PEG 4000, 0.1 M Na Acetate pH 4.6, 0.2 M Ammonium Sulfate
4. 12% Isopropanol, 0.1 M Na Acetate pH 4.6, 0.1 M Na Chloride
5. 12% PEG 4000, 0.1 M Na Acetate pH 4.6
6. 1.0 M Ammonium Sulfate, 0.1 M Na Acetate pH 4.6
7. 1.0 M Mg Sulfate, 0.1 M Na Acetate pH 4.6
8. 18% PEG 400, 0.1 M Na Acetate pH 4.6, 0.1 M Mg Chloride
9. 1.0 M Ammonium Phosphate, 0.1 M Na Acetate pH 4.6, 0.1 M Li Sulfate
10. 12% PEG 6000, 0.1 M Na Acetate pH 4.6, 0.1 M Na Chloride
11. 12% PEG 6000, 0.1 M Na Acetate pH 4.6, 0.1 M Mg Chloride
12. 18% PEG 400, 0.1 M Na Citrate pH 5.6, 0.1 M Na Chloride
13. 12% PEG 4000, 0.1 M Na Citrate pH 5.6, 0.1 M Li Sulfate
14. 10% Isopropanol, 0.1 M Na Citrate pH 5.6, 0.1 M Na Citrate
15. 12% MPD, 0.1 M Na Citrate pH 5.6, 0.1 M Na Chloride
16. 1.0 M Mg Sulfate, 0.1 M Na Citrate pH 5.6
17. 12% PEG 4000, 0.1 M Na Citrate pH 5.6, 0.1 M Na Chloride
18. 12% PEG 6000, 0.1 M Na Citrate pH 5.6, 0.1 M Li Sulfate
19. 4% MPD, 0.1 M Na Citrate pH 5.6, 0.1 M Mg Chloride
20. 0.1 M Na Chloride, 0.1 M Na Citrate pH 5.6
21. 4% PEG 400, 0.1 M Na Citrate pH 5.6, 0.1 M Li Sulfate
22. 1.0 M Ammonium Sulfate, 0.1 M ADA pH 6.5
23. 12% PEG 4000 2% Isopropanol, 0.1 M ADA pH 6.5, 0.1 M Li Sulfate
24. 1.0 M di-Ammonium Phosphate, 0.1 M ADA pH 6.5

**FIG. 9**  
(Continued)

## MembFac Reagent Formulations

25. 12% PEG 6000, 0.1 M ADA pH 6.5, 0.1 M Mg Chloride
26. 12% MPD, 0.1 M ADA pH 6.5
27. 1.0 M Mg Sulfate, 0.1 M ADA pH 6.5, 0.1 M Li Sulfate
28. 4% PEG 400, 0.1 M ADA pH 6.5, 0.3 M Li Sulfate
29. 1.0 M di-Na/K Phosphate, 0.1 Na Hepes pH 7.5, 0.1 M Ammonium Sulfate
30. 10% PEG 4000, 0.1 Na Hepes pH 7.5, 0.1 M Na Chloride
31. 18% PEG 400, 0.1 Na Hepes pH 7.5, 0.1 M Mg Chloride
32. 1.0 M K/Na Tartrate, 0.1 Na Hepes pH 7.5
33. 18% PEG 400, 0.1 Na Hepes pH 7.5, 0.1 M Ammonium Sulfate
34. 10% PEG 4000, 0.1 Na Hepes pH 7.5, 0.1 M Ammonium Sulfate
35. 12% MPD, 0.1 Na Hepes pH 7.5, 0.1 M Na Citrate
36. 1.0 M Na Citrate, 0.1 Na Hepes pH 7.5
37. 4% PEG 400, 0.1 Na Hepes pH 7.5, 0.6 M Mg Sulfate
38. 4% MPD, 0.1 Na Hepes pH 7.5, 0.6 M Mg Sulfate
39. 0.1 M K/Na Tartrate, 0.1 Na Hepes pH 7.5, 0.1 M Li Sulfate
40. 12% MPD, 0.1 M Tris HCl pH 8.5, 0.1 M Li Sulfate
41. 0.5 M di-Na/K Phosphate, 0.1 Tris HCl pH 8.5, 0.1 Ammonium Phosphate
42. 0.1 M Na Acetate, 0.1 Tris HCl pH 8.5
43. 0.1 M Na Chloride, 0.1 Tris HCl pH 8.5
44. 12% PEG 6000, 0.1 Tris HCl pH 8.5, 0.1 M Ammonium Phosphate
45. 0.4 M Mg Sulfate, 0.1 Tris HCl pH 8.5, 0.1 M K/Na Tartrate
46. 0.2 M Li Sulfate, 0.1 Tris HCl pH 8.5
47. 0.5 M Ammonium Sulfate, 0.1 Tris HCl pH 8.5
48. 5% PEG 400, 0.1 Tris HCl pH 8.5, 0.1 M Na Citrate

**FIG. 9**  
(Continued)

## Detergent Screen 1 Reagent Formulations

1. 0.08 mM C<sub>12</sub>E<sub>9</sub>
2. 0.11 mM C<sub>12</sub>E<sub>8</sub>
3. 0.17 mM n-Dodecyl-b-D-maltoside
4. 0.20 mM Sucrose monolaurate
5. 0.56 mM CYMAL-6
6. 0.90 mM TRITON X-100
7. 1.00 mM CTAB
8. 1.40 mM Deoxy BigChap
9. 1.80 mM n-Decyl-b-D-maltoside
10. 2.00 mM LDAO
11. 2.40 mM CYMAL-5
12. 4.00 mM ZWITTERGENT 3-12
13. 6.50 mM Nonyl-b-D-glucoside
14. 9.00 mM I-S-octyl-b-D-thioglucoside
15. 10.4 mM DDAO
16. 19.5 mM HECAMEG
17. 24.4 mM n-Octanoylsucrose
18. 30.0 mM Heptyl-b-D-thioglucoside
19. 24.5 mM n-Octyl-b-D-glucoside
20. 34.5 mM CYMAL-3
21. 35.0 mM C-HEGA-10
22. 40.0 mM ZWITTERGENT 3-10
23. 79.0 mM MEGA-8
24. 250.0 mM n-Hexyl-b-D-glucoside

**Note:** [mM] is that of the CMC of the detergent

**FIG. 9**  
(Continued)

## Crystal Screen Cryo Reagent Formulations

1. 30% MPD, 0.1 M Na Acetate pH 4.6, 0.02 M Calcium Chloride
2. 0.26 M K, Na Tartrate, 35% Glycerol
3. 0.26 M Ammonium Phosphate, 35% Glycerol
4. 1.5 M Ammonium Sulfate, 0.075 M Tris HCl pH 8.5, 25% Glycerol
5. 30% MPD, 0.1 M Sodium Hepes pH 7.5, 0.2 M sodium Citrate
6. 24% PEG 4000, 0.08 M Tris HCl pH 8.5, 0.16 M Magnesium Chloride, 20% Glycerol
7. 0.98 M Sodium Acetate, 0.07 M Na Cacodylate pH 6.5, 30% Glycerol
8. 21% iso-Propanol, 0.07 M Na Cacodylate pH 6.5, 0.14 M Sodium Citrate, 30% Glycerol
9. 25.5% PEG 4000, 0.085 M Na Citrate pH 5.6, 0.17 M Ammonium Acetate, 15% Glycerol
10. 25.5% PEG 4000, 0.085 M Na Acetate pH 4.6, 0.17 M Ammonium Acetate, 15% Glycerol
11. 0.7 M Ammonium Phosphate, 0.07 M Na Citrate pH 5.6, 30% Glycerol
12. 27% iso-Propanol, 0.09 M Na Hepes pH 7.5, 0.18 M Magnesium Chloride, 10% Glycerol
13. 30% PEG 400, 0.1 M Tris HCl pH 8.5, 0.2 M Sodium Citrate
14. 26.6% PEG 400, 0.095 M Na Hepes pH 7.5, 0.19 M Calcium Chloride, 5% Glycerol
15. 25.5% PEG 8000, 0.085 M Na Cacodylate pH 6.5, 0.17 M Ammonium Sulfate, 15 % Glycerol
16. 1.125 M Lithium Sulfate, 0.075 M Na Hepes pH 7.5, 25% Glycerol
17. 25.5% PEG 4000, 0.085 M Tris HCl pH 8.5, 0.17 M Lithium Sulfate, 15% Glycerol
18. 16% PEG 8000, 0.08 M Na Cacodylate pH 6.5, 0.16 M Magnesium Acetate, 20% Glycerol
19. 24% iso-Propanol, 0.08 M Tris HCl pH 8.5, 0.16 M Ammonium Acetate, 20% Glycerol
20. 20% PEG 4000, 0.08 M Na Acetate pH 4.6, 0.16 M Ammonium Sulfate, 20% Glycerol
21. 30% MPD, 0.1 M Na Cacodylate pH 6.5, 0.2 M Magnesium Acetate
22. 25.5% PEG 4000, 0.085 M Tris HCl pH 8.5, 0.17 M Sodium Acetate, 15% Glycerol
23. 30% PEG 400, 0.1 M NA Hepes pH 7.5, 0.2 M Magnesium Chloride
24. 14% iso-Propanol, 0.07 M Na Acetate pH 4.6, 0.14 M Calcium Chloride, 30% Glycerol

**FIG. 9**  
(Continued)

## Crystal Screen Cryo Reagent Formulations

25. 0.7 M Sodium Acetate, 0.07 M Imidazole pH 6.5, 30% Glycerol
26. 30% MPD, 0.1 M Na Citrate pH 5.6, 0.2 M Ammonium Acetate
27. 14% iso- Propanol, 0.07 M NA Hepes pH 7.5, 0.14 M Sodium Citrate, 30% Glycerol
28. 25.5% PEG 8000, 0.085 M Na Cacodylate pH 6.5, 0.17 M Sodium Acetate, 15% Glycerol
29. 0.52 M K, Na Tartrate, 0.065 M Na Hepes pH 7.5, 35% Glycerol
30. 25.5% PEG 8000, 0.17 M Ammonium Sulfate, 15% Glycerol
31. 25.5% PEG 4000, 0.17 M Ammonium Sulfate, 15% Glycerol
32. 1.5 M Ammonium Sulfate, 25% Glycerol
33. 3.6 M Sodium Formate, 10% Glycerol
34. 1.4 M Sodium Formate, 0.07 M Na Acetate pH 4.6, 30% Glycerol
35. 1.2 M Na, K Phosphate, 0.075 M Na Hepes pH 7.5, 25% Glycerol
36. 5.2% PEG 8000, 0.065 M Tris Hcl pH 8.5, 35% Glycerol
37. 5.6% PEG 4000, 0.07 M Na Acetate pH 4.6, 30% Glycerol
38. 1.26 M Sodium Citrate, 0.09 M Na Hepes pH 7.5, 10% Glycerol
39. 1.7% PEG 400, 0.085 M Na Hepes pH 7.5, 1.7 M Ammonium Sulfate, 15% Glycerol
40. 19% iso-Propanol, 0.095 M Na Citrate pH 5.6, 19% PEG 4000, 5% Glycerol
41. 8.5% iso-Propanol, 0.085 M Na Hepes pH 7.5, 17% PEG 4000, 15% Glycerol
42. 16% PEG 8000, 0.04 M Potassium Phosphate, 20% Glycerol
43. 24% PEG 1500, 20% Glycerol
44. 0.1 M Magnesium Formate, 50% Glycerol
45. 14.4% PEG 8000, 0.08 M Na Cacodylate pH 6.5, 0.16 M Zinc Acetate, 20% Glycerol
46. 14.4% PEG 8000, 0.08 M Na Cacodylate pH 6.5, 0.16 M Calcium Acetate, 20% Glycerol
47. 1.6 M Ammonium Sulfate, 0.08 M Na Acetate pH 4.6, 20% Glycerol
48. 1.6 M Ammonium Phosphate, 0.08 M Tris HCl pH 8.5, 20% Glycerol

**FIG. 9**  
(Continued)



## Low Ionic Strength Screen Reagent Formulations

### Buffers

1. 0.05 M Potassium chloride pH 2.0
2. 0.05 M Citric acid pH 3.0
3. 0.05 M Citric acid pH 3.5
4. 0.05 M Citric acid pH 4.0
5. 0.05 M Citric acid pH 4.5
6. 0.05 M Citric acid pH 5.0
7. 0.05 M Citric acid pH 5.5
8. 0.05 M MES pH 6.0
9. 0.05 M Bis-Tris pH 6.5
10. 0.05 M Imidazole pH 7.0
11. 0.05 M Hepes pH 7.5
12. 0.05 M Tris pH 8.0
13. 0.05 M Tris pH 8.5
14. 0.05 M Glycine pH 9.0
15. 0.05 M Glycine pH 9.5
16. 0.05 M Glycine pH 10.0
17. 0.05 M di-sodium hydrogen phosphate pH 11.0
18. 0.05 M di-sodium hydrogen phosphate pH 12.0

### Precipitants

- A. 4% w/v Polyethylene glycol 3350
- B. 8% w/v Polyethylene glycol 3350
- C. 12% w/v Polyethylene glycol 3350
- D. 16% w/v Polyethylene glycol 3350
- E. 20% w/v Polyethylene glycol 3350
- F. 24% w/v Polyethylene glycol 3350

### Dehydrant

- 24% w/v Polyethylene glycol 3350

FIG. 9  
(Continued)

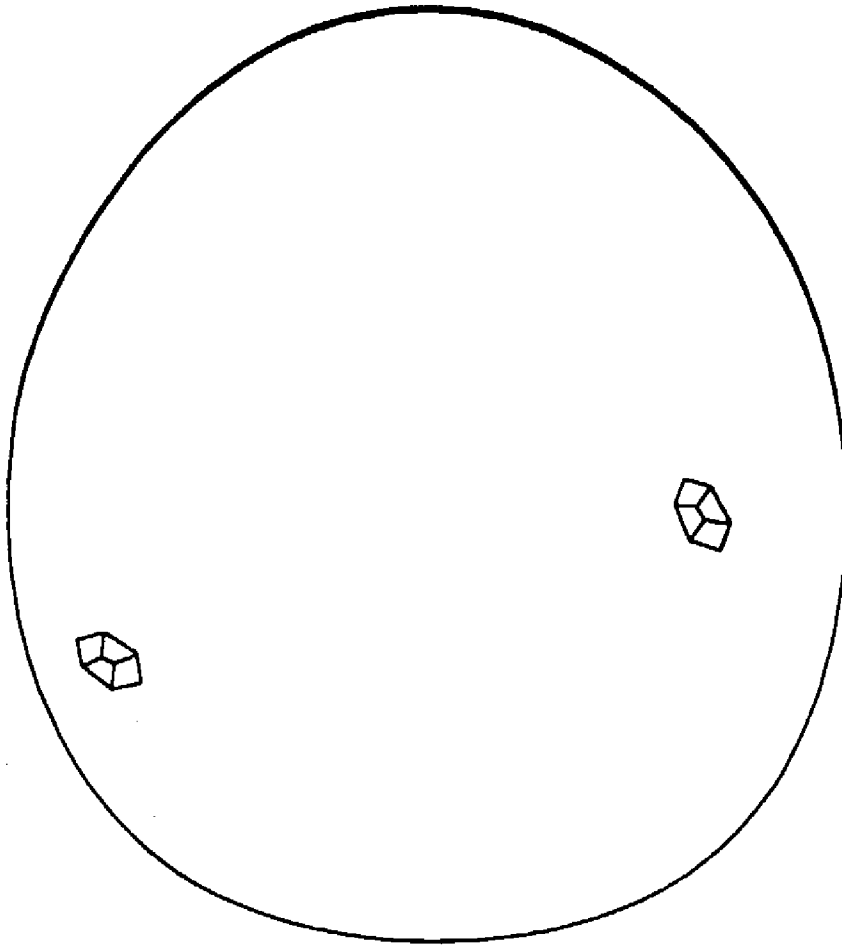

FIG. 10A

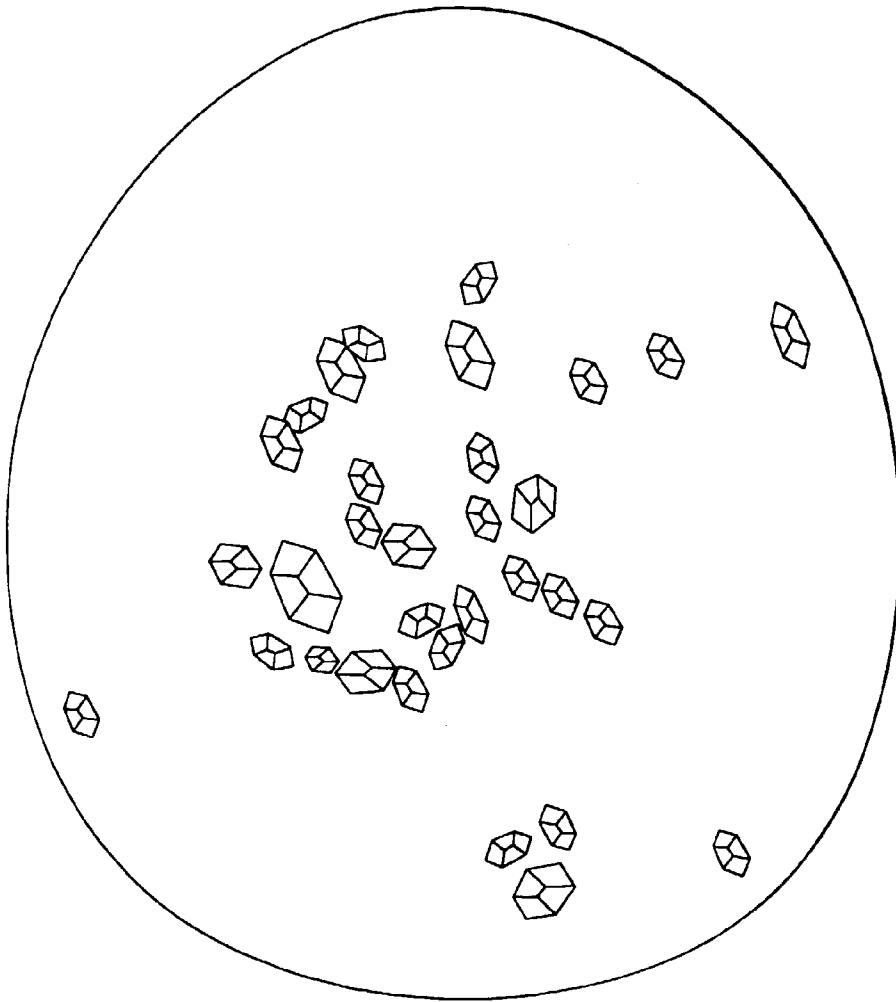

FIG. 10B

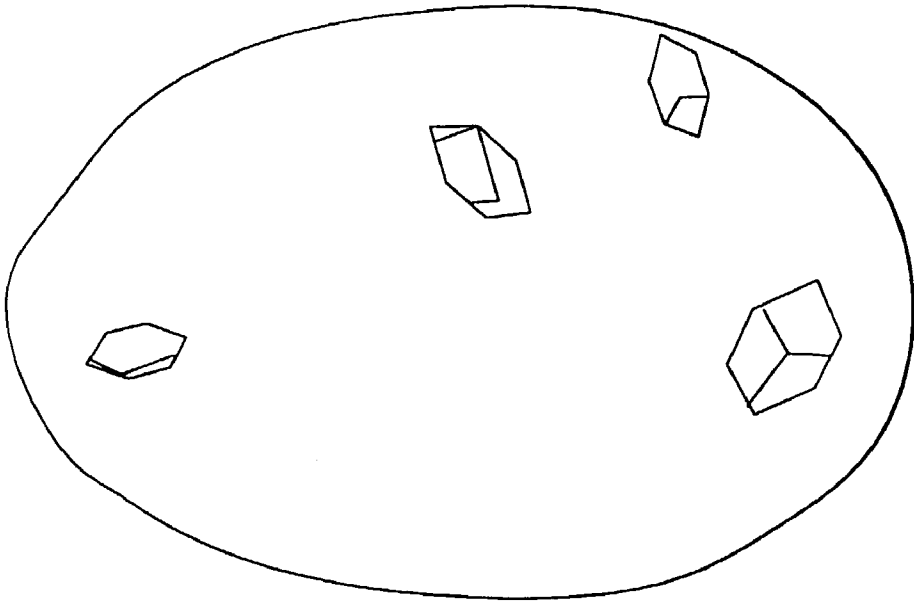

FIG. 10C

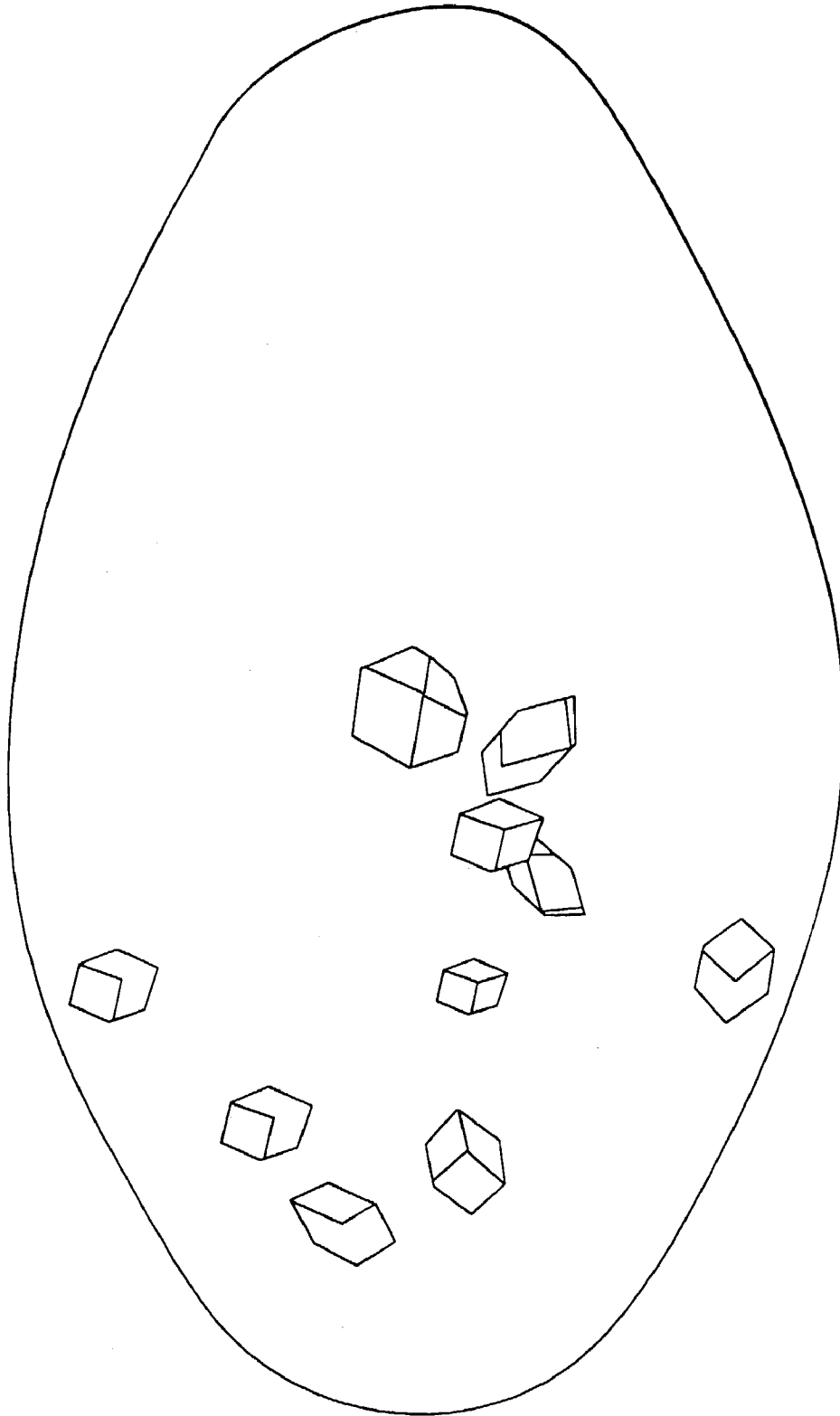

FIG. 10D

Concentration of CaCl <sub>2</sub> (mM)	pH		4.1	4.3	4.5	4.7	4.9	5.1
12.5			1.6 A	1.6 A	1.6 A	1.6 A	1.6 A	1.6 A
			8.3 B	8.3 B	8.3 B	8.3 B	8.3 B	8.3 B
			75.0 C	75.0 C	75.0 C	75.0 C	75.0 C	75.0 C
			19.3 D	16.9 D	14.1 D	11.4 D	8.7 D	6.3 D
		145.8 W	148.3 W	151.0 W	153.7 W	156.4 W	158.8 W	158.8 W
17.5			2.2 A	2.2 A	2.2 A	2.2 A	2.2 A	2.2 A
			8.3 B	8.3 B	8.3 B	8.3 B	8.3 B	8.3 B
			75.0 C	75.0 C	75.0 C	75.0 C	75.0 C	75.0 C
			19.3 D	16.9 D	14.1 D	11.4 D	8.7 D	6.3 D
		145.2 W	147.6 W	150.3 W	153.1 W	155.8 W	158.2 W	158.2 W
22.5			2.8 A	2.8 A	2.8 A	2.8 A	2.8 A	2.8 A
			8.3 B	8.3 B	8.3 B	8.3 B	8.3 B	8.3 B
			75.0 C	75.0 C	75.0 C	75.0 C	75.0 C	75.0 C
			19.3 D	16.9 D	14.1 D	11.4 D	8.7 D	6.3 D
		144.6 W	147.0 W	149.7 W	152.5 W	155.2 W	157.6 W	157.6 W
27.5			3.4 A	3.4 A	3.4 A	3.4 A	3.4 A	3.4 A
			8.3 B	8.3 B	8.3 B	8.3 B	8.3 B	8.3 B
			75.0 C	75.0 C	75.0 C	75.0 C	75.0 C	75.0 C
			19.3 D	16.9 D	14.1 D	11.4 D	8.7 D	6.3 D
		143.9 W	146.4 W	149.1 W	151.9 W	154.5 W	157.0 W	157.0 W

FIG. 11

A = volume of 2M CaCl<sub>2</sub>  
 B = volume of 3M NaOAc  
 C = volume of 100% MPD  
 D = volume of 1M HCl  
 W = volume of 100% water

## Crystal Screen 2 Reagent Formulations

1. 10% PEG 6000 , 2.0 M Na chloride
2. 0.5 M NaCl, 0.01 M CTAB, 0.01 M Mg chloride
3. 25% Ethylene glycol
4. 35% Dioxane
5. 5% Isopropanol, 2.0 M Ammonium sulfate
6. 1.0 M Imidazole pH 7.0
7. 10% PEG 1000, 10% PEG 8000
8. 10% Ethanol, 1.5 M Na chloride
9. 2.0 M Na chloride, 0.1 M Na acetate pH 4.6
10. 30% MPD, 0.1 M Na Acetate pH 4.6, 0.2 M NaCl
11. 1.0 M 1,6 Hexanediol, 0.1 M Na Acetate pH 4.6, 0.01 M Co chloride
12. 30% PEG 400, 0.1 M Na acetate pH 4.6, 0.1 M Cd chloride
13. 30% PEG MME 2000, 0.1 M Na Acetate pH 4.6, 0.2 M Ammonium sulfate
14. 2.0 M Ammonium sulfate, 0.1 M Na Citrate pH 5.6, 0.2 M K/Na Tartrate
15. 1.0 M Li sulfate, 0.1 M Na Citrate pH 5.6, 0.5 M Ammonium sulfate
16. 2% Polyethyleneimine, 0.1 M Na Citrate pH 5.6, 0.5 M Na chloride
17. 35% tert-butanol, 0.1 M Na citrate pH 5.6
18. 10% Jeffamine M-600, 0.1 M Na citrate pH 5.6, 0.01 M Ferric chloride
19. 2.5 M 1,6 Hexanediol, 0.1 M Na citrate pH 5.6
20. 1.6 M Mg sulfate, 0.1 M MES pH 6.5
21. 2.0 M Na chloride, 0.1 M MES pH 6.5, 0.2 M Na/K Phosphate
22. 12% PEG 20,000, 0.1 M MES pH 6.5
23. 10% Dioxane, 0.1 M MES pH 6.5, 1.6 M Ammonium sulfate
24. 30% Jeffamine M-600, 0.1 M MES pH 6.5, 0.05 M Cs chloride

FIG. 11  
(Continued)

## Crystal Screen 2 Reagent Formulations

25. 1.8 M Ammonium sulfate, 0.1 M MES pH 6.5, 0.01 M Co chloride
26. 30% PEG MME 5000, 0.1 M MES pH 6.5, 0.2 M Ammonium sulfate
27. 25% PEG MME 550, 0.1 M MES pH 6.5, 0.01 M Zn sulfate
28. 1.6 M Sodium citrate pH 6.5
29. 30% MPD, 0.1 M Hepes pH 7.5, 0.5 M Ammonium sulfate
30. 10% PEG 6000, 0.1 M Hepes pH 7.5, 5% MPD
31. 20% Jeffamine M-600, 0.1 M Hepes pH 7.5
32. 1.6 M Ammonium sulfate, 0.1 M Hepes pH 7.5, 0.1 M Na chloride
33. 2.0 M Ammonium formate, 0.1 M Hepes pH 7.5
34. 1.0 M Na acetate, 0.1 M Hepes pH 7.5, 0.05 M Cd sulfate
35. 70% MPD, 0.1 M Hepes pH 7.5
36. 4.3 M Na chloride, 0.1 M Hepes pH 7.5
37. 10% PEG 8000, 0.1 M Hepes pH 7.5, 8% Ethylene glycol
38. 20% PEG 10,000, 0.1 M Hepes pH 7.5
39. 3.4 M 1,6 Hexanediol, 0.1 M Tris pH 8.5, 0.2 M Mg chloride
40. 25% tert-butanol, 0.1 M Tris pH 8.5, 0.1 M Ca chloride
41. 1.0 M Li sulfate, 0.1 M Tris pH 8.5, 0.01 M Ni chloride
42. 12% Glycerol, 0.1 M Tris pH 8.5, 1.5 M Ammonium sulfate
43. 50% MPD, 0.1 M Tris pH 8.5, 0.2 M Ammonium phosphate
44. 20% Ethanol, 0.1 M Tris pH 8.5
45. 20% PEG MME 2000, 0.1 M Tris pH 8.5, 0.01 M Ni chloride
46. 30% PEG MME 550, 0.1 M Bicine pH 9.0, 0.1 M Na chloride
47. 2.0 M Mg chloride, 0.1 M Bicine pH 9.0
48. 10% PEG 20,000, 0.1 M Bicine pH 9.0, 2% Dioxane

**FIG. 11**  
(Continued)



FIGURE 12A

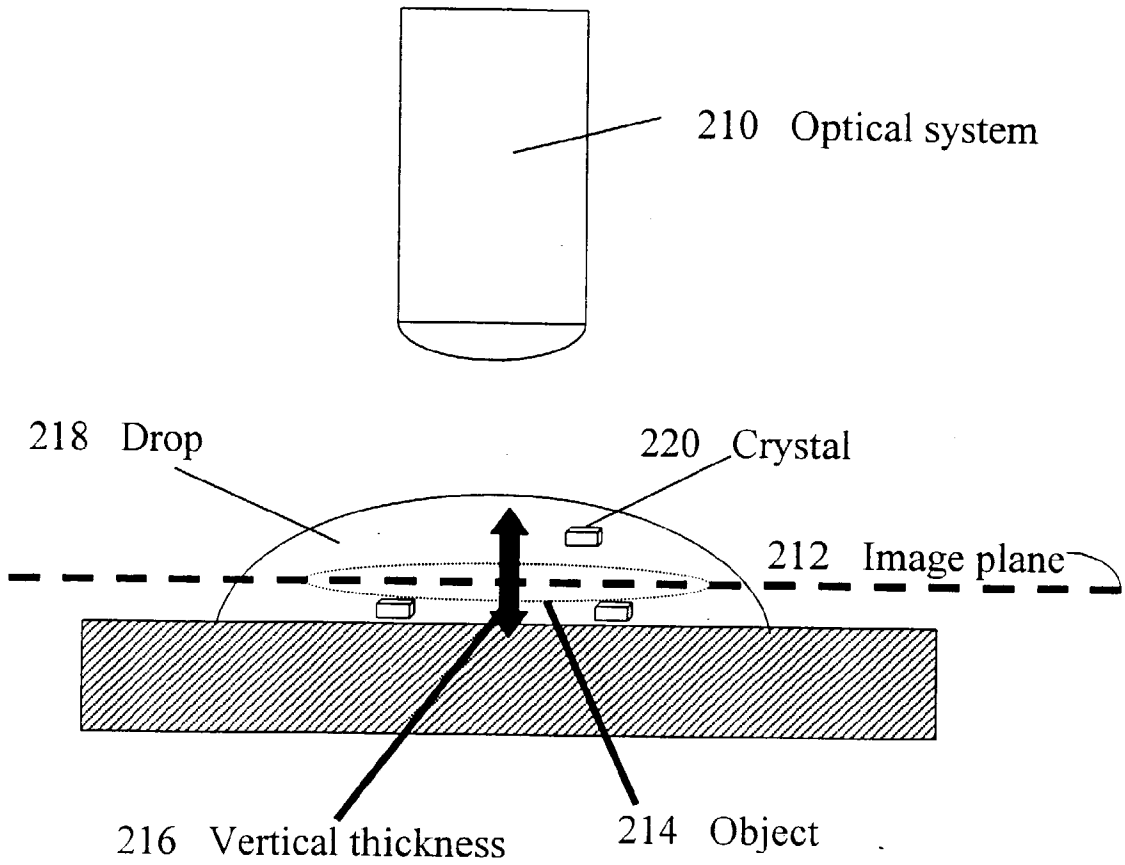

**FIGURE 12B**

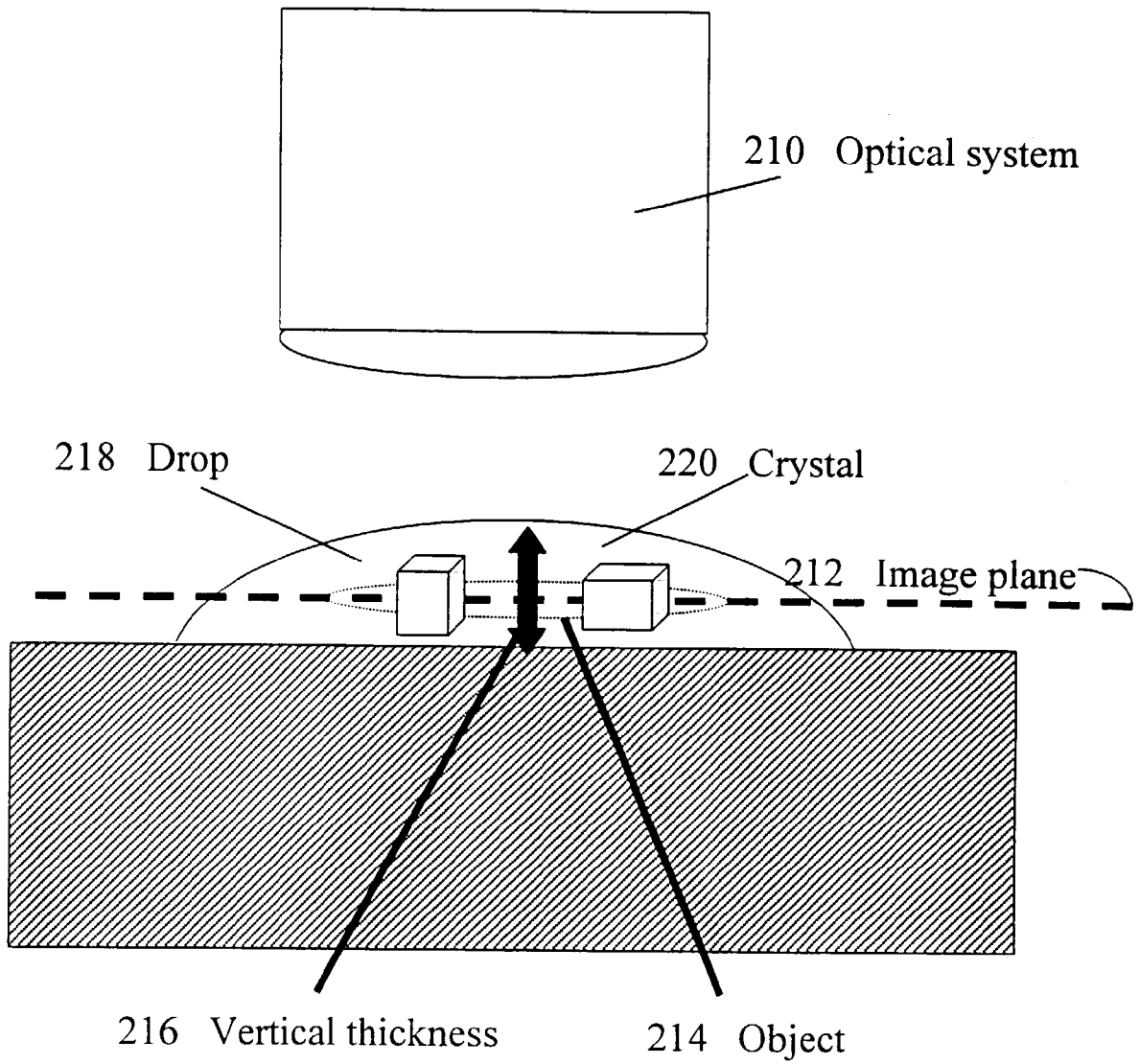

## AUTOMATED CRYSTALLIZATION EXPERIMENT SETUP APPARATUS COMPRISING SENSOR

### CROSS-REFERENCE TO RELATED APPLICATIONS

[0001] This application is a Continuation-in-Part of U.S. application Ser. No. 09/336,134, filed Jun. 18, 1999, which is incorporated herein by reference.

### BACKGROUND OF THE INVENTION

[0002] 1. Field of the Invention

[0003] The present invention relates to methods and apparatuses for crystallizing molecules and, more particularly, to methods and apparatuses for automating the crystallization of molecules, particularly macromolecules such as proteins.

[0004] 2. Description of Related Art

[0005] Fast progress in the area of genomics has provided explosively growing databases of information on genes of human and other organisms by mapping, sequencing and analyzing their genomes. Many genes that may be critical for identifying people predisposed to certain diseases such as cancer have been discovered and their biological functions have been assessed in vitro and/or in vivo. Recently, a new area of genomics, functional genomics, has been developed, which involves a genome wide analysis of gene function by using information and reagents from the genomic analysis and expressing the genes in various organisms such as yeast. Functional genomics has generated important information regarding the expression pattern of genes by using high throughput screening techniques such as DNA oligonucleotide chips for specific genes or high density microarrays. An understanding of the network of interactions between a protein expressed by a target gene and other macromolecules in the cell is also being expanded at an unprecedented rate by using efficient screening methods such as the yeast hybrid systems.

[0006] One of the ultimate goals of these genome projects is the development of efficacious therapeutics against proteins expressed by disease genes. Among various methods of drug discovery and development, structure-based drug development has become one of the most important approaches, thanks to rapidly advancing computation techniques. It is well recognized that understanding of the detailed three-dimensional structure of a protein not only assists in rational drug design and development in the laboratory but also provides a well-defined target in high throughput drug screening by using computer-aided docking analysis.

[0007] Solving high resolution structures of protein in a high throughput fashion presents a major bottleneck in such a chain of genomics and drug development. High resolution structures of proteins are solved by X-ray crystallography, and more recently by using multi-dimensional NMR spectroscopy on high-field NMR machines for smaller proteins or peptides.

[0008] Various methods for X-ray crystallography have been developed, including the free interface diffusion method (Salemme, F. R. (1972) Arch. Biochem. Biophys. 151:533-539), vapor diffusion in the hanging or sitting drop method (McPherson, A. (1982) Preparation and Analysis of

Protein Crystals, John Wiley and Son, New York, pp 82-127), and liquid dialysis (Bailey, K. (1940) Nature 145:934-935).

[0009] Presently, the hanging drop method is the most commonly used method for growing macromolecular crystals from solution, especially for protein crystals. Generally, a droplet containing a protein solution is spotted on a cover slip and suspended in a sealed chamber which contains a reservoir with a higher concentration of precipitating agent. Over time, the solution in the droplet equilibrates with the reservoir by diffusing water vapor from the droplet, thereby slowly increasing the concentration of the protein and precipitating agent within the droplet, which in turn results in precipitation or crystallization of the protein.

[0010] The process of growing crystals with high diffraction quality is time-consuming and involves trial-and-error experimentations on multiple solution variables such as pH, temperature, ionic strength, and specific concentrations of salts, organic additives, and detergents. In addition, the amount of highly purified protein is usually limited, multi-dimensional trials on these solution conditions is unrealistic, labor-intensive and costly.

[0011] A few automated crystallization systems have been developed based on the hanging drop methods, for example Cox, M. J. and Weber, P. C. (1987) J. Appl. Cryst. 20:366; and Ward, K. B. et al. (1988) J. Crystal Growth 90:325-339. A need exists for improved automated crystallization systems for proteins and other macromolecules.

### SUMMARY OF THE INVENTION

[0012] The present invention relates to a method for performing array microcrystallizations to determine suitable crystallization conditions for a molecule. The molecule may be a molecule for which an x-ray crystal structure is needed. Determining high-resolution structures of molecules by a high-throughput method such as the one of the present invention can be used to accelerate drug development. The molecule to be crystallized may also be a molecule for which a crystalline form of the molecule is needed. For example, it may be desirable to create a crystalline form of a molecule or to identify new crystalline forms of a molecule. In some instances, particular crystalline forms of a molecule may have more bioactive, dissolve faster, decompose less readily, and/or be easier to purify. The molecule is preferably a macromolecule such as a protein but may also be other types of macromolecules. The molecule preferably has a molecular weight of at least 500 Daltons, more preferably at least 1000 Daltons, although smaller molecular weight molecules may also be crystallized.

[0013] In one embodiment, the method comprises: forming an array of microcrystallizations, each microcrystallization including a drop containing a molecule to be crystallized and a mother liquor solution whose composition varies within the array, the drop having a volume of less than 1 L; storing the array of microcrystallizations under conditions suitable for molecule crystals to form in the drops in the array; and detecting molecule crystal formation in the drops.

[0014] In one variation, the method comprises: forming an array of microcrystallizations, each microcrystallization comprising a well including a mother liquor solution whose composition varies within the array, and drop region includ-

ing a drop containing the molecule to be crystallized, the drop having a volume of less than 1 L; storing the array of microcrystallizations under conditions suitable for molecule crystals to form in the drops in the array; and detecting molecule crystal formation in the drops.

[0015] In another variation, the method comprises: forming an array of microcrystallizations, each microcrystallization comprising a well including a mother liquor solution whose composition varies within the array, and a coverslip including a drop containing the molecule to be crystallized, the drop having a volume of less than 1 L; storing the array of microcrystallizations under conditions suitable for molecule crystals to form in the drops in the array; and detecting molecule crystal formation in the drops.

[0016] In yet another variation, the method comprises: forming an array of microcrystallizations, each microcrystallization comprising a well including a mother liquor solution whose composition varies within the array, and sitting drop region including a drop containing the molecule to be crystallized, the drop having a volume of less than 1 L; storing the array of microcrystallizations under conditions suitable for molecule crystals to form in the drops in the array; and detecting molecule crystal formation in the drops.

[0017] According to any of the above methods, the volume of the drop containing the molecule to be crystallized is less than about 1 L, preferably less than about 750 nL, more preferably less than about 500 nL, and most preferably less than about 250 nL. In one variation, the drop volume is between 1 nL and 1000 nL, preferably between 1 nL-750 nL, more preferably between 1 nL-500 nL, more preferably between 1 nL-250 nL, and most preferably between 1 nL-250 nL.

[0018] The present invention also relates to plates for performing array microcrystallizations to determine suitable crystallization conditions for a molecule. According to one embodiment, the plate comprises an array of at least 36 wells for holding a mother liquor solution, each well having a reservoir volume of less than about 500 L, preferably less than about 400 L, more preferably less than about 300 L and optionally less than about 250 L. Ranges of well volumes that may be used include, but are not limited to 25 L-500 L and 25 L-300 L. In one variation, the plate is designed to perform a hanging drop crystallization. In another variation, the plate is designed to perform a sitting drop crystallization and includes a mother liquor well as well as an adjacent sitting drop well.

[0019] The present invention also relates to various apparatuses for forming submicroliter drops used in an array microcrystallization to determine suitable crystallization conditions for a molecule.

[0020] In one embodiment, the apparatus comprises:

[0021] a platform on which a multiwell plate is positionable;

[0022] a mother liquor drop station capable of removing mother liquor from a plurality of wells of the multiwell plate and delivering submicroliter volumes of mother liquor to drop regions on the multiwell plate within a volume range of less than about 25 nL; and

[0023] a molecule drop station capable of delivering submicroliter volumes of a solution containing a molecule to be crystallized to the drop regions within a volume range of less than about 25 nL.

[0024] In another embodiment the apparatus is designed for preparing submicroliter hanging drops on cover slips used in an array microcrystallization, the apparatus comprising:

[0025] a platform on which a multiwell plate is positionable;

[0026] a cover slip station on which a plurality of coverslips are positionable;

[0027] a mother liquor drop station capable of removing mother liquor from a plurality of wells of the multiwell plate and delivering submicroliter volumes of mother liquor to the plurality of coverslips within a volume range of less than about 25 nL; and

[0028] a molecule drop station capable of delivering submicroliter volumes of a solution containing a molecule to be crystallized to the plurality of coverslips within a volume range of less than about 25 nL.

[0029] In yet another embodiment the apparatus is designed for preparing submicroliter sitting drops used in an array microcrystallization, the apparatus comprising:

[0030] a platform on which a multiwell plate is positionable;

[0031] a mother liquor drop station capable of removing mother liquor from a plurality of wells of the multiwell plate and delivering submicroliter volumes of mother liquor to drop regions on the multiwell plate within a volume range of less than about 25 nL; and

[0032] a molecule drop station capable of delivering submicroliter volumes of a solution containing a molecule to be crystallized to the drop regions within a volume range of less than about 25 nL.

[0033] According to any of the above embodiments, the mother liquor drop station and the molecule drop station are each capable of delivering submicroliter volumes within a volume range of less than about 20 nL, more preferably less than 15 nL, and most preferably less than 10 nL.

[0034] Also according to any of the above embodiments, a sensor may be included in the apparatus for preparing submicroliter drops which detects whether mother liquor drops and/or molecule drops have been formed.

[0035] The mother liquor drop station and the molecule drop station are preferably each independently capable of delivering submicroliter volumes to at least four coverslips at a time, more preferably at least eight coverslips at a time.

[0036] The present invention also relates to methods for forming submicroliter drops for use in an array microcrystallization to determine suitable crystallization conditions for a molecule. According to one embodiment, the method includes: removing mother liquor from a plurality of wells of a multiwell plate; delivering submicroliter volumes of the mother liquor to drop regions of the multiwell plate within a volume range of less than about 25 nL; and delivering

submicroliter volumes of a solution containing a molecule to be crystallized to the drop regions of the multiwell plate within a volume range of less than about 25 nL; wherein a total volume of the submicroliter volumes delivered to each drop region is less than 1 L.

[0037] According to another embodiment, the method is for a hanging drop crystallization and includes: taking a plurality of coverslips; removing mother liquor from a plurality of wells of a multiwell plate; delivering submicroliter volumes of the mother liquor to the plurality of coverslips within a volume range of less than about 25 nL; and delivering submicroliter volumes of a solution containing a molecule to be crystallized to the plurality of coverslips within a volume range of less than about 25 nL; wherein a total volume of the submicroliter volumes delivered to each coverslip is less than 1 L.

[0038] According to another embodiment, the method is for a sitting drop crystallization and includes: removing mother liquor from a plurality of wells of a multiwell plate; delivering submicroliter volumes of the mother liquor to sitting drop regions of the multiwell plate within a volume range of less than about 25 nL; and delivering submicroliter volumes of a solution containing a molecule to be crystallized to the sitting drop regions within a volume range of less than about 25 nL; wherein a total volume of the submicroliter volumes delivered to each sitting drop region is less than 1 L.

[0039] According to any of the above method embodiments, the total volume of the submicroliter volumes delivered is preferably less than about 750 nL, more preferably less than about 500 nL, and most preferably less than about 250 nL. It is noted that the drop volumes may be as small as 380 pL. The volumes delivered preferably range between 1 nL-750 nL, more preferably between 1 nL-500 nL, more preferably between 1 nL-250 nL, and most preferably between 10 nL-250 nL.

[0040] According to any of the above apparatus and method embodiments, the precision of the volumes delivered is preferably less than about 25 nL, more preferably less than 20 nL, more preferably less than 15 nL, and most preferably less than 10 nL. The precision of the volumes delivered may also be between 380 pL and 25 nL, more preferably between 380 pL and 20 nL, more preferably between 380 pL and 15 nL, and most preferably between 380 pL and 10 nL.

#### BRIEF DESCRIPTION OF THE FIGURES

[0041] FIG. 1 is a block diagram of a crystallization system according to the present invention.

[0042] FIG. 2 illustrates a method for using the crystallization system of FIG. 1 to perform a protein crystallization trial.

[0043] FIG. 3A illustrates a top view of a multiwell plate which may be used to perform a hanging drop array microcrystallization.

[0044] FIG. 3B is a sideview of the multiwell plate illustrated in FIG. 3A.

[0045] FIG. 3C illustrates a top view of a multiwell plate which may be used to perform a sitting drop array microcrystallization.

[0046] FIG. 3D is a sideview of the multiwell plate illustrated in FIG. 3C.

[0047] FIG. 3E is a cross section of a multiwell plate with a plate cover.

[0048] FIGS. 4A-4J illustrate the various stations which can be included in a mother liquor delivery system.

[0049] FIG. 4A is a sideview of a plate loading station looking across a plate track positioned adjacent to the plate loading station.

[0050] FIG. 4B is a sideview of a plate loading station looking along the longitudinal axis of the plate track.

[0051] FIG. 4C is a sideview of a bar code reading station for reading a bar code included on a multiwell plate.

[0052] FIG. 4D is a sideview of a sealing medium station for applying a sealing medium to an upper edge of wells defined in a multiwell plate.

[0053] FIG. 4E is a sideview of a plate cover removal station for removing a plate cover from a multiwell plate.

[0054] FIG. 4F is a topview of a mother liquor delivery station.

[0055] FIG. 4G is a topview of a delivery block for delivery of a mother liquor into multiwell plates.

[0056] FIG. 4H is a cross section of a delivery block for delivery of a mother liquor into a multiwell plates.

[0057] FIG. 4I is a sideview of a mother liquor source storage bank.

[0058] FIG. 4J is a sideview of a syringe pump for delivering a mother liquor from a mother liquor source to a fluid injector.

[0059] FIGS. 5A-5E illustrate the various stations which can be included in a drop formation system.

[0060] FIG. 5A is a top view of a drop formation station.

[0061] FIG. 5B is a sideview of the drop formation station.

[0062] FIG. 5C is a sideview of a pipette holder.

[0063] FIG. 5D is a sideview of a well cover holder.

[0064] FIG. 5E is a sideview of a well cover magazine for storing well covers to be positioned over the wells in a multiwell plate.

[0065] FIGS. 6A-6I illustrate operation of the drop formation station.

[0066] FIG. 6A illustrates a drop formation station in the rest position.

[0067] FIG. 6B illustrate the drop formation station with a multiwell plate has been moved into position for drop formation and a pipette holder is moved into position over the wash basin.

[0068] FIG. 6C illustrates the pipette holder moved into position over a column of wells in the multiwell plate.

[0069] FIG. 6D illustrates the pipette holder moved into position over the well cover holder.

[0070] FIG. 6E illustrates the pipette holder returned to its rest position and a protein delivery pipette moved into position over a well cover.

[0071] FIG. 6F illustrates the protein delivery pipette moved into its rest position and the cover holder inverted and moved into position over the column of wells on the multiwell plate.

[0072] FIG. 6G illustrates hanging drops suspended from well covers over the wells of a plate.

[0073] FIG. 6H illustrates the cover holder moved into position over a well cover storage component.

[0074] FIG. 6I illustrates the cover holder returned to its rest position.

[0075] FIGS. 7A-7G illustrate operation of the drop formation station to form sitting drops.

[0076] FIG. 7A illustrates a drop formation station in the rest position.

[0077] FIG. 7B illustrate the drop formation station with a multiwell plate adapted to perform a sitting drop array microcrystallization in position for drop formation and a pipette holder moved into position over the wash basin.

[0078] FIG. 7C illustrates the pipette holder moved into position over a column of wells in the multiwell plate.

[0079] FIG. 7D illustrates pipettes in the pipette holder aligned with the well regions of wells in a column of the plate.

[0080] FIG. 7E illustrates pipettes in the pipette holder aligned with the sitting drop regions of wells in a column of the plate.

[0081] FIG. 7F illustrates the protein delivery pipette moved into position over the sitting drop region of a well in the column of wells.

[0082] FIG. 7G illustrates a sitting drop formed in the sitting drop region of a well.

[0083] FIG. 8A is a sideview of a plate track with a pin extending above the plate track from a pin carriage positioned beneath the plate track.

[0084] FIG. 8B is a sideview of a plate track with a pin of FIG. 8A withdrawn beneath the plate track.

[0085] FIG. 8C is a sideview of a transport assembly having a plurality of pin carriages.

[0086] FIG. 9 illustrates the composition of 480 mother liquor solutions for a preferred coarse screen.

[0087] FIGS. 10A-10D illustrate formation of crystals in different drops sized from 40 nL to 1000 nL.

[0088] FIG. 11 lists the mother liquor compositions for 24 mother liquors used in the fine screen stage of a crystallization trial.

[0089] FIG. 12A illustrates an optical system for screening crystallization experiments for crystals.

[0090] FIG. 12B illustrates an optical system for screening small drop volume crystallization experiments for crystals.

#### DETAILED DESCRIPTION

[0091] The present invention relates to a method for performing array microcrystallizations to determine suitable crystallization conditions for a molecule. The molecule is preferably a macromolecule, such as a protein. Other types of molecules and macromolecules may also be crystallized according to the present invention. The molecule preferably has a molecular weight of at least 500 Daltons, more preferably at least 1000 Daltons, although it is noted that the invention can be applied to molecules with lower molecular weights.

[0092] The method involves forming an array of microcrystallizations where each microcrystallization includes a drop containing a molecule to be crystallized and a mother liquor solution whose composition varies within the array, the drop having a volume of less than 1 L. The array of microcrystallizations are stored under conditions suitable for molecule crystals to form in the drops in the array. Molecule crystal formation is then detected in the drops. As will be described herein, this method can be employed in any crystallization method involving drops, including, but not limited to hanging drop crystallization methods and sitting drop crystallization methods. Example sitting drop crystallization methods are provided in U.S. Pat. No. 5,096, 676 (McPherson et al.) and U.S. Pat. No. 5,419,278 (Carter).

[0093] An important feature of the present invention is the utilization of small drop volumes. For example, the volume of the drop containing the molecule to be crystallized is less than about 1 L, preferably less than about 750 nL, more preferably less than about 500 nL, and most preferably less than about 250 nL. In one variation, the drop volume is between 1 nL and 1000 nL, preferably between 1 nL-750 nL, more preferably between 1 nL-500 nL, more preferably between 1 nL-250 nL, and most preferably between 10 nL-250 nL.

[0094] Applicants believe that the rate of crystallization is dependent on the drop volume where crystals form faster when smaller drop volumes are used. As a result, crystals can be formed more rapidly by using the smaller drop volumes used in the present invention. This significantly increases the through-put rate of the method for determining crystallization conditions.

[0095] Without being bound by theory, it is believed that smaller drops will equilibrate faster than larger drops and that this causes crystals to form more rapidly. The rate of equilibration is believed to be related to a relationship between the rate of drop evaporation and drop volume. Meanwhile, the rate of drop evaporation is dependent on drop surface area. The surface area of a drop does not decrease linearly with the drop's volume. As a result, a larger drop having twenty times the volume of a smaller drop (e.g., 1 L vs. 50 nL) will have significantly less than twenty times the surface area of the smaller drop. By reducing drop volume, one is able to improve the relationship between the rate of drop evaporation (surface area dependent) and drop volume, thereby accelerating equilibration and crystal formation.

[0096] A further advantage of the present invention is that smaller drop volumes allow less molecule to be used to perform each crystallization trial.

[0097] As a result, a greater number of crystallization trials can be performed using the same amount of molecule.

This is of great significance when it is difficult to obtain the molecule to be crystallized and when a large number of crystallization trials are needed in order to successfully crystallize the molecule.

[0098] It is frequently difficult to produce and purify the molecule being crystallized. In the case of protein crystallization, it can require one to two weeks of lab work to produce and purify enough protein to perform 48 crystallization trials using drops greater than 1 L in size. By reducing the drop volume and hence the amount of molecule used per crystallization trial, it becomes feasible to significantly increase the number of crystallization trials that can be performed. As a result, it becomes feasible to take a more combinatorial, shotgun approach to molecule crystallization trials since the pressure to conserve molecule usage is reduced. By contrast, prior to the present invention's utilization of sub microliter drop volumes, a need existed to minimize the number of trials that were performed at one time due to a shortage of available molecule.

[0099] By reducing the drop volume, the number of microcrystallizations that can be performed in the array is increased. The number of microcrystallizations in the array is typically greater than 48, preferably greater than 96, more preferably greater than 144, most preferably greater than 192. It is noted that the number of microcrystallizations in the array can also exceed 288 or 384. For example, an apparatus for preparing arrays which include 480 microcrystallizations is described herein.

[0100] Increasing the number of microcrystallizations that can be performed in the array also allows a greater number of different stock solutions to be used to form the mother liquor solutions used in the array. For example, forming the array of microcrystallizations can include using greater than 48 stock solutions to form the mother liquor solutions used in the array. Optionally, greater than 96, more preferably greater than 144, most preferably greater than 192 different stock solutions may be used. It is noted that the number of stock solutions can also exceed 288 or 384. For example, an apparatus described herein uses 480 different stock solutions.

[0101] Smaller volumes of mother liquor may also be used in the wells. The volume of mother liquor used in the wells is preferably less than about 500 L, preferably less than about 400 L, more preferably less than about 300 L and optionally less than about 250 L. Ranges of mother liquor volumes that may be used include, but are not limited to 25 L-500 L and 25 L-300 L. In this regard, forming the array of microcrystallizations may include forming the microcrystallizations in a plate including a plurality of wells each having a volume less than about 500 L, preferably less than about 400 L, more preferably less than about 300 L.

[0102] The use of small volumes of mother liquor allows the wells in multiwell plates to be made smaller, thereby allowing more wells to be positioned on a multiwell plate per unit area. For example, the 48 well plates having a well volume less than about 500 L has approximately the same footprint as 24 well plates typically used to perform protein crystallization. Further reduction of the mother liquor volumes may be employed in order to further reduce plate sizes.

[0103] By utilizing small drop volumes, a significantly greater number of crystallization trials can be performed

using the same amount of molecule. As a result, it is feasible to perform a greater number of crystallization trials, which in turn allows the mother liquor solution to be more widely varied in its composition. This allows the mother liquor solution to be formed of 1, 2, 3, 4, 5, 6 or more components which are varied within the array.

[0104] Also according to this method, the array of microcrystallizations is formed of one or more multiwell plates. Each plate preferably has at least 24 wells, more preferably at least 36 wells, and most preferably at least 48 wells. By utilizing less mother liquor, smaller wells can be used which allows the same size plate to contain more wells.

[0105] Also according to this method, detecting crystal formation can include characterizing the crystal formed (needle, cube, etc.), the size of the crystal, and the quality of the crystal's structure. Characterization of the crystal can be performed manually, or by taking images of the drops and analyzing those images for the structure of crystals contained within those drops.

[0106] As noted elsewhere, an objective of the present invention is to provide a high throughput methodology for testing crystallization conditions. By reducing crystallization volumes, the present invention allows one to perform many more crystallization experiments using the same amount of protein. However, when one performs many more crystallization experiments, it then becomes necessary to screen these many more crystallization experiments for crystals.

[0107] FIG. 12A illustrates an optical system 210 for screening crystallization experiments for crystals. As illustrated, the optical system 210 has an image plane 212. Objects 214 which are transected by the image plane 212 are in focus. Objects outside the image plane 212 are not in focus. Depending on the depth of field of the optics used, objects outside the image plane can be seen, but with decreased resolution. Ultimately, the depth of field that can be imaged is dependent on the numerical aperture of the optical system.

[0108] The positioning of the image plane 212 is dependent upon the focal length of the optics used in the optical system and the positioning of the optical system 210 relative to the object 214 to be imaged. Focusing the optical system 210 causes the image plane 212 to move vertically toward or away from the optical system 210.

[0109] FIG. 12A illustrates a crystallization experiment where the crystallization volume employed (in this case a drop) is larger than those used in the present invention. As illustrated, when larger drop volumes are employed, the vertical thickness 216 of the drop 218 is such that crystals 220 can be present in the drop and outside of the image plane 212 of optical system 210. As a result, it is necessary to adjust the focus of the optical system 210. This causes the image plane 212 to move vertically across the vertical thickness 216 of the drop 218 so that the entire drop can be screened for crystals.

[0110] An advantageous feature of performing crystallizations using small drop volumes according to the present invention is that the need to focus the optical system in order to screen for crystals within the drop is eliminated. As illustrated in FIG. 12B, when one images a drop having a small drop volume, the vertical thickness 216 of the drop

**218** is sufficiently small that a crystal, if present, will transect the focal plane **212** of the optical system if the focal plane is positioned within the drop, preferably around the middle of the drop. This is shown experimentally herein with regard to FIGS. **10A-10D**. As a result, it is unnecessary to adjust the focus the optical system in order scan a drop for crystals. As a result, a single image of a drop can be taken in order to evaluate whether crystals are present in the drop.

[**0111**] As noted above, by reducing drop volumes, the present invention allows one to perform many more crystallization experiments using the same amount of protein. At the same time, the reduced drop volumes of the present invention also allows one to screen crystallization experiments for crystals more rapidly by eliminating the need to adjust the focus of an optical system used to image the crystallization experiments.

[**0112**] The method can also include identifying the compositions of those mother liquor solutions in which crystals were detected and performing additional crystallization trials where the formulation of the mother liquor solutions in which crystals were detected is further varied.

[**0113**] FIG. **1** illustrates a crystallization system **10** for performing a crystallization trial. The crystallization system **10** can be divided into various stations **12** described below. During operation of the crystallization system **10**, multiwell plates are positioned on a plate track **14**. A transport assembly (not shown) moves the multiwell plates along the plate track **14** to the various stations **12**.

[**0114**] The crystallization system **10** also includes a processing unit **16** in electrical communication with the various stations **12**. Suitable processing units **16** for use with the crystallization system **10** include, but are not limited to, PCs and computer workstations. The processing unit **16** includes process control logic for controlling the operation of each station and the transport assembly. An operator can use one or more user interfaces to interact with, disengage and/or to alter the process control logic. Suitable user interfaces include, but are not limited to computer monitors, keyboards, mouses, and trackballs.

[**0115**] During operation of the crystallization system **10**, the transport assembly moves a multiwell plate past the stations **12** which each perform a particular function. For instance, the crystallization system **10** includes a plate loading station **18** where multiwell plates are sequentially loaded onto the plate track **14**. The crystallization system **10** also includes a bar code reading station **20** where a bar code on the multiwell plates can be read. The crystallization system **10** further includes a sealing medium station **22**. The sealing medium station **22** can be used to apply a sealing medium to the multiwell plates. Specifically, the sealing medium can be applied to the upper edge of liquid receiving wells defined in each multiwell plate. The sealing medium serves to form a seal between the upper edges of each well and a well cover, commonly referred to as a coverslip, which is positioned over each well at a later station of the crystallization system **10**. The crystallization system **10** also includes a plate cover removal station **24** where plate covers **44** are delivered to or removed from the multiwell plates.

[**0116**] The crystallization system **10** also includes a mother liquor delivery station **26** where mother liquors are delivered into the wells defined in the multiwell plates.

Different mother liquors can be delivered into different wells or the same mother liquor can be delivered into more than one well. Further, mother liquor can be delivered into a portion of the wells on a single multiwell plate so the remaining wells are empty.

[**0117**] The crystallization system **10** also includes a drop formation station **28** where mother liquors from the various wells are used to form one or more drops on a plurality of coverslips that will be placed over the wells. The drop formation station **28** also adds a solution containing the molecule to be crystallized to the coverslips. Once drops containing mother liquor and the molecule to be crystallized are formed on the coverslips, the coverslips are positioned over each well such that the one or more drops hang from the coverslip into the well. These drops are called hanging drops.

[**0118**] It is noted that the drop formation station can be readily adapted to form sitting drops in a sitting drop regions of a multiwell plate by delivering mother liquors from the various wells and the solution containing the molecule to be crystallized to the sitting drop regions.

[**0119**] The crystallization system **10** also includes a plate cover delivery station **29** where plate covers **44** can be positioned on each multiwell plate. The multiwell plate can then be transported to a plate unloading station **30** where the multiwell plates can be removed from the plate track **14** and stored.

[**0120**] Although the crystallization system **10** illustrated in FIG. **1** has the various stations **12** positioned around a single plate track **14**, it is noted that the various stations **12** can be divided into one or more sub-systems, each optionally having its own track. It is further noted that many of the stations **12** may optionally be included or excluded from the crystallization system **10**. Further, the stations **12** can be positioned in a sequence other than the sequence illustrated in FIG. **1**. For instance, the plate cover removal station **24** can be positioned before the bar code reading station **20**. Additionally, several of the described functions can be carried out at a single station. For instance, a plate cover delivery station **29** can be formed integrally with the drop formation station **28** or the plate unloading station **30**.

[**0121**] The above stations **12** can be included in a single system or can each be included in different independent sub-systems. For instance, the tray loading station, bar code reading station **20**, sealing medium station **22** and mother liquor delivery station **26** can be included in a single mother liquor delivery system **31** while the drop formation station **28** and the plate unloading station **30** can be included in an independent drop formation system **32**. Additionally, the functions associated with a particular station need not be carried out during operation of the crystallization system **10**. For instance, the mother liquors can be delivered into the wells of a multiwell plate by an external apparatus before the multiwell plate enters the crystallization system **10**. In such an instance, when a multiwell plate already containing mother liquor reaches the mother liquor delivery station **26**, the mother liquor delivery station **26** can be operated to not deliver mother liquors into the wells.

[**0122**] After a microcrystallization array has been prepared by processing a multiwell plate through a crystallization system **10** such as the one illustrated in FIG. **1**, drops



in the microcrystallization array can be observed for the formation of crystals. When crystals are formed in a drop of a particular well, the quality of crystals within the drop can be graded for various characteristics such as shape, size or time for crystal formation. When the mother liquors used in each well are different, the crystal grades can be compared to determine which mother liquor was associated with the most desirable crystals. Accordingly, each well serves as a different crystallization experiment which produces results which can be compared with the results of other crystallization experiments.

[0123] A crystallization trial includes comparing the results of several crystallization experiments in order to optimize the composition of the mother liquor used for crystallization of a particular molecule. FIG. 2 illustrates a technique for performing a crystallization trial. A coarse screen is performed at an initial stage of the trial. In FIG. 2, the crystallization experiments associated with the coarse screen are illustrated as a plurality of boxes set out in three different arrays which are labeled CS<sub>1</sub>, CS<sub>2</sub> and CS<sub>3</sub>. In each array two variables of the mother liquor composition are incrementally varied as shown along the x and y axis associated with each array. For instance, in CS<sub>1</sub> several crystallization experiments are performed where the pH is varied from 2-8 in intervals of 2 and the % (NH<sub>4</sub>)<sub>2</sub>SO<sub>4</sub> is varied from 20-80 in intervals of 20.

[0124] The crystallization experiments in the coarse screen are analyzed to select one or more crystallization experiments which yield the best crystals or, if no crystals form, the best crystal-like precipitate. A coarse screen experiment selected as producing a promising crystal or crystal-like precipitate is illustrated as a black box in FIG. 2. Fine screens are then performed for the crystallization experiments selected through the coarse screen.

[0125] A fine screen crystallization experiment is performed by designing a crystallization array based on the mother liquor composition used in a crystallization experiment selected through the coarse screen, indicated in FIG. 2 as the array labeled FS<sub>1</sub>. The compositions of the mother liquors used in the fine screen crystallization array are selected by making small variations in the composition of the mother liquor used in the selected experiment from the coarse screen. For example, if the mother liquors used in the coarse screen had a pH between 2-8 and the mother liquor in the selected crystallization had a pH of 4.0, the mother liquors used in the fine screen experiments might have a pH between 3.4 to 4.6. Further, by focusing the array around mother liquors having a pH of about 4, one can reduce the incremental change in the value in the fine screen FS<sub>1</sub>. For instance, the incremental change in the pH during the coarse screen CS<sub>2</sub> shown in FIG. 2 is 2.0 while the incremental change of the pH during the fine screen also shown in FIG. 2 is 0.4.

[0126] Crystals formed in each crystallization experiment in the fine screen are analyzed in order to select the one or more crystallization experiments yielding the best crystals or crystal-like precipitate. A crystallization experiment selected during the fine screen experiment is illustrated in FIG. 2 as a box having an X. If the crystals formed during the fine screen are of a sufficiently high quality, one might isolate the crystals formed in the experiment and perform x-ray diffraction on the isolated crystals to resolve the molecule's

crystal structure. Alternatively, one might use the mother liquor used in the selected fine screen experiment in order to grow additional crystals. However, if the crystals formed during the fine screen are not of a sufficiently high quality, the mother liquor can be further optimized by taking the mother liquor used in the selected fine screen experiment as the starting point for an additional fine screen. FIG. 2 illustrates a second array of fine screen crystallization experiments labeled FS<sub>2</sub>. It is noted that this iterative process of selecting a fine screen experiment and performing a finer screen array based on a selected experiment can be repeated until a suitable mother liquor is identified for use in preparing crystals.

[0127] The microcrystallization methods and apparatuses of the present invention may be used to perform the coarse screen array experiments described in regard to FIG. 2 in order to analyze a larger set of mother liquors than had previously been feasible with drop sizes larger than 1 microliter. It is noted that the fine screen array experiments may also be performed using the microcrystallization methods and apparatuses of the present invention or may be performed where drop sizes are larger than 1 microliter.

[0128] FIG. 3A illustrates a top view of a multiwell plate 34 which may be used with the methods and apparatuses of the present invention to perform a hanging drop array microcrystallization. As illustrated, the multiwell plate 34 includes a support structure 36 defining wells 38 arranged in 6 columns and 8 rows. Although FIG. 3A illustrates a multiwell plate 34 with a total of 48 wells 38, the multiwell plate 34 can include a different number of wells 38.

[0129] FIG. 3B provides a sideview of the multiwell plate 34 illustrated in FIG. 3A. Each well 38 includes an upper edge 40 extending above the support structure 36. The upper edge 40 is preferably wide enough that a layer of a sealing medium, such as grease, can be applied to the upper edge 40. The support structure 36 preferably has a geometry which allows multiwell plates 34 to be stacked on top of one another without one multiwell plate 34 interfering with the well contents of an adjacent multiwell plate 34.

[0130] FIG. 3C illustrates a top view of a multiwell plate 34 which may be used with the methods and apparatuses of the present invention to perform a sitting drop array microcrystallization. As illustrated, the multiwell plate 34 includes a support structure 36 defining 48 wells 38 arranged in 6 columns and 8 rows. Although a multiwell plate 34 with 48 wells 38 is illustrated the multiwell plate 34 can include a different number of wells 38. A well region 41 is adjacent to a sitting drop region 42. Although the sitting drop region 42 is illustrated as being centrally positioned within the well 38, the sitting drop region 42 can be positioned to one side of the well 38.

[0131] FIG. 3D provides a sideview of the multiwell plate 34 illustrated in FIG. 3C. The sitting drop region 42 extends upward from the bottom of the well 38. As illustrated by the cut-away, the sitting drop region 42 can include a recess where a sitting drop can be formed. Each well 38 includes an upper edge 40 extending above the support structure 36. The upper edge 40 is preferably wide enough that a layer of a sealing medium, such as grease, can be applied to the upper edge 40. The support structure 36 preferably has a geometry which allows multiwell plates 34 to be stacked on top of one another without one multiwell plate 34 interfering with the well 38 contents of an adjacent multiwell plate 34.

[0132] A plate cover 44 can be positioned over each multiwell plate 34 as illustrated in FIG. 3E. The plate cover 44 can be designed so the cover rests on the upper edges 40 of the wells 38. As illustrated in FIG. 3E an insert 46 can be positioned between the plate cover 44 and the multiwell plate 34 so the insert 46 rests on the upper edges 40 of the wells 38. The insert 46 can be removable from the plate cover 44 or can be permanently attached to the plate cover 44. The insert 46 can be formed from a flexible material so the insert 46 provides a seal between the insert 46 and the upper edges 40 of the wells 38 in order to reduce evaporation from the wells 38. Suitable materials for the insert 46 include, but are not limited to, soft rubbers and other gasket material.

[0133] As illustrated in FIG. 3A, the multiwell plate 34 can include a bar code 48 formed on the support structure 36. The multiwell plate 34 can also include a surface 50 sized to receive a bar code sticker. Alternatively, a bar code can be formed on a plate cover 44 or the plate cover 44 can include a surface sized to receive a bar code sticker. When the multiwell plate 34 or plate cover 44 includes a surface for receiving a bar code sticker, the bar code sticker is preferably removable from the multiwell plate 34 so different bar codes can be fixed to a single multiwell plate 34. As will be discussed later, these bar codes can be used to identify the multiwell plate 34 and/or the contents of the multiwell plate 34 to the system control logic.

[0134] FIGS. 4A-4J illustrate embodiments of the various stations 12 of the mother liquor delivery system 31 illustrated in FIG. 1. FIGS. 4A and 4B illustrate a plate loading station 18 for sequentially loading multiwell plates 34 onto a plate track 14. FIG. 4A is a sideview of the plate loading station 18 looking across the plate track 14 and FIG. 4B is a sideview of the plate loading station 18 looking down the longitudinal axis of the plate track 14. The plate loading station 18 includes a tower 52 positioned over the plate track 14 so the plate track 14 extends outward from the base of the tower 52. The tower 52 includes a chute 54 sized to receive a stack of multiwell plates 34 arranged one on top of another.

[0135] The plate loading station 18 also includes plate lowering mechanics (not shown) which can be engaged to lower a multiwell plate 34 at the bottom of the stack onto the plate track 14. The action of gravity moves a new multiwell plate 34 into the position of the multiwell plate 34 lowered onto the plate track 14. The clearance between the plate tower 52 and the plate track 14 is enough for the plate transport assembly to transport the multiwell plate 34 lowered onto the plate track 14 out from under the tower 52 as illustrated in FIG. 4A. Once the multiwell plate 34 has been transported from beneath the tower 52, plate lowering mechanics can be re-engaged so a new multiwell plate 34 at the bottom of the chute 54 is also loaded onto the plate track 14. Because the plate loading station 18 can hold several multiwell plates 34 and sequentially position each multiwell plate 34 on the plate track 14, the mother liquor delivery system 31 can process many multiwell plates 34 without an operator manually positioning each multiwell plate 34 on the plate track 14.

[0136] The plate loading station 18 can be easily adapted into a plate 34 unloading station by operating the plate lowering mechanics in reverse. This reverse operation causes a multiwell plate 34 located beneath the tower 52 to

be raised from the plate track 14 and added to the stack of multiwell plates 34 stored within the chute 54.

[0137] FIG. 4C illustrates a bar code reading station 20. A bar code reader 56 is positioned alongside the plate track 14. The bar code reader 56 is directed toward the plate track 14 at an angle which permits the bar code reader 56 to read a bar code 48 on a multiwell plate 34 on the plate track 14. As described above, these bar codes can be formed on the multiwell plate 34 or can be included on a bar code sticker to be placed on the multiwell plates 34. The bar code reader 56 is monitored by the system control logic which associates each bar code with a particular multiwell plate 34 and/or with particular characteristics of a multiwell plate 34. Suitable characteristics include, but are not limited to, the number of wells 38 in the multiwell plate 34, the volume of the wells 38 in the multiwell plate 34, whether the multiwell plate 34 includes a plate cover 44, etc.

[0138] The characteristics of a multiwell plate 34 can be administratively entered in order to indicate information about the multiwell plate 34 to the system control logic. For instance, a user can enter characteristics such as identifying particular mother liquids to be delivered into particular wells 38 on a multiwell plate 34. Further, if an operator uses an external method to deliver mother liquids into the wells 38 of the multiwell plate 34, the user can indicate this to the system control logic. Because various mother liquids are already present in the wells 38 of the multiwell plate 34, the system control logic can override mother liquid delivery station in order to avoid delivering additional mother liquids to the wells 38 of the multiwell plate 34.

[0139] As a multiwell plate 34 moves through the mother liquor delivery system 31, the drop formation system 32 and/or through the crystallization system 10, the characteristics associated with the multiwell plate 34 can optionally be modified by the system control logic in order to reflect the changing status of the multiwell plate 34. For example, the system control logic can note when mother liquor has been added, or when drops have been formed.

[0140] FIG. 4D illustrates a sealing medium station 22. The sealing medium station 22 includes a sealing member 60 suspended over the plate track 14 at a height which permits multiwell plates 34 to be moved under the sealing member 60. The sealing member 60 includes a sealing surface 62 with a plurality of sealing medium injectors 64 arranged so each sealing medium injector can be concurrently aligned with a well 38 in each multiwell plate 34. The sealing medium injectors 64 are in hydraulic communication with a sealing medium source 66. Accordingly, a sealing medium can be delivered from the sealing medium source 66 to the portion of the sealing surface 62 adjacent to the sealing medium injectors 64.

[0141] The sealing member 60 can be coupled with actuators for moving the sealing member 60 relative to the wells 38 on a multiwell plate 34. The sealing member 60 can be moved vertically over a multiwell plate 34 as illustrated by the arrows labeled A. The sealing member 60 can also be translated laterally relative to a multiwell plate 34 as illustrated by the arrows labeled B. Suitable actuators include, but are not limited to, pneumatic pistons, hydraulic pistons and electrically driven motors.

[0142] In operation of the sealing medium station 22, the plate transport assembly transports a multiwell plate 34 into

a position where the wells 38 in the multiwell plate 34 are positioned beneath the sealing medium injectors 64. The sealing member 60 is lowered until the sealing surface 62 is in contact with the upper edge 40 of the wells 38 on the multiwell plate 34. Because the wells 38 of the multiwell plate 34 are aligned with the sealing medium injectors 64 before the downward motion of the sealing member 60, the upper edge 40 of each well 38 encircles a sealing medium injector. Once, the sealing surface 62 is in contact with the upper edges 40 of the wells 38, the sealing member 60 is laterally translated. The lateral translation causes the sealing member 60 to follow a circular path along an edge of the well 38, although other paths may also be used depending on the geometry of the wells 38. This lateral translation transfers the sealing medium delivered to the sealing surface 62 to the upper edge 40 of each well 38.

[0143] The amount of sealing medium transferred to the upper edge 40 of each well 38 depends on the amount of sealing medium present on the sealing surface 62 adjacent to the sealing medium injectors 64. The amount of sealing medium delivered to the upper edges 40 of the wells 38 should be sufficient to create a substantially airtight seal between a coverslip and the upper edge 40 of the well 38. Suitable sealing mediums include, but are not limited to, grease and vasaline.

[0144] It is noted in regard to the sealing medium station 22 that the station may be readily adapted for use with hanging drop array crystallizations as well as with sitting drop array crystallizations. In regard to each type of drop array crystallization, an airtight seal should be formed between the edges of a well 38 and a coverslip or other form of covering member which is placed over the well 38.

[0145] FIG. 4E is a sideview of a plate cover 44 removal station 24 positioned adjacent a plate track 14. The plate cover 44 removal station 24 includes a carriage 68 configured to move vertically as illustrated by the arrow labeled A and laterally as illustrated by the arrow labeled B. A plurality of vacuum fittings 70 are coupled with the carriage 68 and are in pneumatic communication with a releasable vacuum source. Suitable vacuum fittings include, but are not limited to, rubber fittings having a cup shape and including a vacuum port in pneumatic communication with a vacuum source.

[0146] During operation of the plate cover removal station 24, the plate transport assembly moves a multiwell plate 34 into position next to the plate cover removal station 24. If the multiwell plate 34 has a plate cover 44, the carriage 68 is moved laterally until each of the vacuum fittings 70 are positioned over the multiwell plate 34. The carriage 68 is lowered until at least a portion of the vacuum fittings 70 are in contact with the plate cover 44. The vacuum source is activated in order to immobilize the plate cover 44 relative to the carriage 68. The carriage 68 is then raised to its original height. The vertical motion of the carriage 68 lifts the plate cover 44 from the multiwell plate 34. The carriage 68 is then moved laterally until the carriage 68 is positioned over a plate cover storage component 72. The carriage 68 is lowered into the plate cover storage component 72 and the vacuum source disengaged in order to drop the plate cover 44 into the plate cover storage component 72. Finally, the carriage 68 is then returned to its original position.

[0147] The plate cover removal station 24 can be adapted to a plate cover delivery station 29 by operating the plate

cover removal station 24 in reverse. The reverse operation causes a plate cover 44 to be removed from the plate cover storage component 72 and then placed on a multiwell plate 34. When a crystallization system 10 uses both a plate cover removal station 24 and a plate cover delivery station 29, the plate covers 44 used with the plate cover removal station 24 can be the same as or different from the plate covers 44 used with the plate cover delivery station 29.

[0148] FIG. 4F is a top view of a mother liquor delivery station 26 where a mother liquor is delivered into the wells 38 of a multiwell plate 34. The mother liquor delivery station 26 includes a plurality of delivery shuttles 74. Each shuttle includes a delivery block 76 configured to slide along block supports 78. The delivery blocks 76 are coupled with block actuators 80 to slide the delivery blocks 76 in a lateral direction relative to the plate track 14 as illustrated by the arrow labeled A. Suitable block actuators 80 include, but are not limited to, pneumatic pistons, hydraulic pistons and electric motors.

[0149] FIG. 4G provides a top view of a delivery block 76. A plurality of lumens 82 extend through the delivery block 76. The lumens 82 are divided into a first delivery group 84 and a second delivery group 86. A fluid injector 88, such as a syringe, can be removably positioned in each of the lumens 82 as illustrated in FIG. 4H. The lumens 82 in each delivery group 84, 86 are arranged on the delivery block 76 so each fluid injector 88 can be concurrently aligned with a different well 38 of a multiwell plate 34. Accordingly, the number of lumens 82 in each delivery group 84, 86 is preferably equal to the number of wells 38 in the multiwell plate 34. For instance, when the multiwell plates 34 include 48 wells 38, each delivery group 84, 86 preferably includes 48 lumens 82.

[0150] Each fluid injector 88 is in fluid communication with a mother liquor source. More than one fluid injector 88 can be in fluid communication with a single mother liquor source. However, each fluid injector 88 is preferably in fluid communication with a different mother liquor source. FIG. 4H illustrates a mother liquor delivery station 26 having five first delivery groups 84 and five second delivery groups 86 which each include 48 fluid injectors 88. Accordingly, 480 mother liquor sources are required when each fluid injector 88 is in fluid communication with a different mother liquor source.

[0151] FIG. 4I is a sideview of a mother liquor source storage bank 90 for holding different mother liquor sources 92. The bank 90 includes source holders 94 arranged in five columns and four rows. Each source holder 94 can hold a plurality of mother liquor sources 92 and can be slid in and out of the bank 90 to provide easy access to the mother liquor sources 92 being held by a single source holder 94. When each multiwell plate 34 has 48 wells 38, each source holder 94 preferably holds 12 different mother liquor sources 92. Accordingly, each column contains 48 mother liquor sources 92 which can each be in fluid communication with a different fluid injector 88 included in the same delivery group 84, 86. As a result, each column of mother liquor sources 92 can be associated with a single delivery group 84, 86. A mother liquor source bank 90 can be included on each side of the plate track 14. The mother liquor sources 92 positioned on one side of the plate track 14 can be in fluid communication with the delivery groups 84,

**86** nearest that side of the track while the mother liquor sources **92** positioned on the opposing side of the plate track **14** can be in fluid communication with the delivery groups **84, 86** on the opposing side of the plate track **14**.

[0152] During operation of the mother liquor delivery station **26**, the plate transport assembly moves a multiwell plate **34** beneath a particular one of the delivery blocks **76**. The block actuators **80** can then move the delivery blocks **76** so the injectors in a particular delivery group **84, 86** are aligned with the wells **38** in the multiwell plate **34**. The particular delivery block **76** and the particular delivery group **84, 86** are associated with the mother liquors which the operator desires to be delivered into the wells **38** of the multiwell plate **34**. The mother liquors are then delivered from the mother liquor sources **92** through the fluid injectors **88** and into the wells **38** which are aligned with the mother liquors. The delivery of mother liquid into each of the wells **38** can occur concurrently and the same volume of mother liquor is preferably delivered into each of the wells **38**.

[0153] FIG. 4J illustrates a syringe pump for delivering mother liquor from mother liquor sources **92** into a well **38** of a multiwell plate **34** through a fluid injector **88**. Mother liquor flows from a mother liquor source **92** to the fluid injector **88** through a fluid conduit **96**. The fluid conduit **96** is in fluid communication with a syringe **98** positioned between the mother liquor source **92** and the fluid injector **88**. The volume within the syringe **100** can be mechanically compressed and expanded as illustrated by the arrow labeled A. A first pinch bar **102** is positioned on an input side of the syringe **104** and a second pinch bar **106** is positioned on an output side of the syringe **108**. The first pinch bar **102** and the second pinch bar **106** are coupled with a rocker bar **110**. In FIG. 4J, the rocker bar **110** occupies a first position where the first pinch bar **102** has pinched the fluid conduit **96** shut on the input side of side of the syringe while the output side of the syringe **108** remains unobstructed. The rocker bar **110** can occupy a second position where the second pinch bar **106** has pinched the fluid conduit **96** shut on the output side of the syringe **108** while the output side of the syringe **108** remains unobstructed. The rocker bar **10** can be automatically moved between the first and second positions as illustrated by the arrow labeled B.

[0154] During operation of the syringe pump, the rocker bar **110** occupies the first position and the volume within the syringe **100** is expanded by the amount of mother liquor to be delivered into a well **38** from the fluid injector **88**. Because the fluid conduit **96** on the output side of the syringe **108** is pinched closed, the expansion of the volume within the syringe **100** by a particular amount causes that particular amount to be withdrawn from the mother liquor source **92**. The rocker bar **110** is then moved to the second position and the volume within the syringe **100** compressed by the amount of mother liquor to be delivered into the well **38** through the fluid injector **88**. Because the fluid conduit **96** on the input side of the syringe **104** is closed, the compression of the volume within the syringe **100** by the particular amount causes that particular amount to flow through the fluid injector **88** and into the associated well **38**.

[0155] The mother liquor delivery section discussed above is for illustrative purposes only and many variations are possible. For instance, a mother liquor delivery station **26** can include more than five delivery shuttles **74** or as few as

one. Further, each delivery shuttle **74** can include more than two delivery groups or a few as one. When a delivery shuttle **74** includes a single delivery group, the block actuators **80** can be eliminated and the delivery shuttles **74** can be stationary relative to the plate track **14**. Additionally, the combination of the plate track **14** movement and the delivery block **76** movement can be used to position a particular fluid injector **88** over a particular well **38** and the mother liquors can be sequentially delivered into the wells **38**. Accordingly, a particular mother liquor can be delivered into a particular well **38**.

[0156] FIGS. 5A-5E illustrate various stations **12** that may be included in a drop formation system **32**. It is noted that the drop formation system **32** illustrated in regard to FIGS. 5A-5E is adapted for a hanging drop array crystallization. The drop formation system **32** can be readily modified for a sitting drop array crystallization by causing the mother liquor drops and molecule solution drops to be deposited on a sitting drop region **42** of a multiwell plate **34**, such as the one illustrated in FIG. 3C, as opposed to on a coverslip.

[0157] FIG. 5A is a top view of a drop formation station **28** and FIG. 5B is a sideview of the drop formation station **28**. The drop formation station **28** includes a wash basin **112** through which a cleansing solution can be flowed. Suitable cleansing solutions include, but are not limited to, water. The drop formation station **28** also includes a molecule solution storage component **114** having one or more molecule solution wells **116** for storing solutions containing the molecule to be crystallized. The molecule solution wells **116** can be capped for storing the molecule solutions when the drop formation system **32** is not in operation. The molecule solution storage component **114** can be refrigerated in order to provide cooling to the molecule solution within the molecule solution wells **116**. For example, when the molecule solution is a molecule solution, the solution is preferably kept at 3-4° C. whether the drop formation station **28** is or is not in operation. The drop formation station **28** also includes syringe pumps **118** and a coverslip storage component **120** for storing coverslips.

[0158] The drop formation station **28** also includes a pipette holder **122** configured to move vertically as indicated by the arrow labeled A and laterally as indicated by the arrows labeled B. The pipette holder's **122** lateral range of motion allows the pipette holder **122** to move to a variety of positions including a position over the wash basin **112** and a position over the coverslip holder **124**. The drop formation station **28** also includes a coverslip holder **124** configured to be inverted as indicated by the arrow labeled C. The coverslip holder **124** can move vertically as indicated by the arrow labeled D and laterally as indicated by the arrows labeled E. The pipette holder's **122** lateral range of motion allows the pipette holder **122** to move to a variety of positions including a position over the coverslip storage component **120** and several positions over the plate track **14**. The drop formation station **28** also includes a molecule delivery pipette **126** which is configured to move vertically as indicated by the arrow labeled F, laterally as indicated by the arrow labeled G and longitudinally as indicated by the arrow labeled H. The longitudinal and lateral ranges of motion allow the molecule delivery pipette **126** to be moved to a variety of positions including a position over each molecule solution well and a plurality of positions over the coverslip holder **124**.

[0159] The above movements can be achieved by coupling the pipette holder 122, coverslip holder 124 and the molecule delivery pipette 126 to a variety of different actuators. Suitable actuators include, but are not limited to, pneumatic pistons, hydraulic pistons and a variety of motors.

[0160] FIG. 5C is a sideview of a pipette holder 122. The pipette holder 122 includes a pipette support frame 128. The pipette support frame 128 holds a number of pipettes 130 equal to the number of wells 38 in a column of a multiwell plate 34. The pipettes 130 are held at a spacing which approximates the spacing between the wells 38 in the column of the multiwell plate 34. This spacing permits each pipette 130 to be concurrently aligned with a different well 38 in the column.

[0161] Each pipette 130 includes a valve 132 and a conduit 134 extending from the valve 132 to a syringe pump 118. The syringe pump 118 can be used to draw fluid into the pipettes 130 and to drive fluid out of the pipettes 130. The valve 132 is configured to deliver drops of a particular size from the pipette 130. These drops are delivered from the pipette 130 until a desired total volume is delivered from the pipette 130. Suitable valves 132 include, but are not limited to, piezoelectric valves and solenoid valves which can be configured to deliver drops as small as 380 pL. This allows production of mother liquor drops as small as 380 pL. Further reduction in the drop size delivered by these pipettes 130 may also be possible, would be desired, and is intended to fall within the scope of the present invention.

[0162] The pipette arrangement used for the molecule delivery pipette 126 is similar to the pipette arrangement used for the pipettes 130 within the pipette holder 122. Accordingly, the molecule delivery pipette 126 also includes a valve 132 and a conduit 134 extending from the valve 132 to a syringe pump 118. The molecule delivery pipette 126 is able to produce molecule solution drops as small as 380 pL. Further reduction in the drop size delivered may also be possible, would be desired, and is intended to fall within the scope of the present invention.

[0163] FIG. 5D is a sideview of a coverslip holder 124. The coverslip holder 124 includes a frame 136 which supports a plurality of support cups 138 shaped to removably hold coverslips at a spacing which approximates the spacing between the wells 38 in a column of the multiwell plate 34. This spacing permits each coverslip to be concurrently aligned with a different well 38 in a column of the multiwell plate 34.

[0164] The support cups 138 can include an attachment mechanism 140 for immobilizing the coverslips in place relative to the support cups 138. The attachment mechanism 140 serves to keep the coverslips in place when the coverslip holder 124 is inverted. However, the attachment mechanisms 140 can release the coverslips at a desired moment. Suitable coverslip holder 124 attachment mechanisms 140 include, but are not limited to, a vacuum source in pneumatic communication with vacuum ports positioned in the support cups 138. Pulling a vacuum through the vacuum ports serves to keep the coverslips in place on the coverslip holder 124. However, when the coverslip holder 124 is inverted, the vacuum can be released by disengaging the vacuum source or reversing the vacuum. The release of the vacuum releases the coverslips from the coverslip holder 124.

[0165] FIG. 5E is a sideview of a coverslip storage component 120 which includes a plurality of magazines 142

sized to hold coverslips 144 stacked on top of one another. The stack of coverslips 144 within the magazine 142 can be biased upward until the coverslip 144 on the top of the stack is near the top of the magazine 142. The spacing between the magazines 142 approximates the spacing between the support cups 138 of the coverslip holder 124. This spacing permits each magazine 142 to be concurrently aligned with a different support cup 138 of the coverslip holder 124. Accordingly, a coverslip 144 from each magazine 142 can also be aligned with a different support cup 138.

[0166] FIGS. 6A-6I illustrate a method for operating the drop formation station 28 to form hanging drops in each of the wells 38 of a multiwell plate 34. The figures are described with respect to crystallization of a protein, however, the same method can be used for crystallization of other types of molecules. FIG. 6A illustrates a drop formation station 28 in the rest position which can be occupied when the drop formation station 28 is not in use or between multiwell plates 34 being transported into the drop formation station 28. In the rest position, coverslips 144 are attached to the coverslip holder 124 which is positioned to one side of the plate track 14 and the pipette holder 122 is positioned to the opposing side of the plate track 14.

[0167] FIG. 6B illustrates a multiwell plate 34 moved into position for drop formation and the pipette holder 122 moved into position over the wash basin 112 for priming of the pipettes 130. The pipette holder 122 is lowered until the pipette tips are within a cleansing solution within the wash basin 112. Cleansing fluid is aspirated from the wash basin 112 and the pipette holder 122 is raised to remove the pipette tips from the cleansing solution. The cleansing fluid is then expelled from the pipettes 130. The process of aspiration and expulsion can be repeated as often as is necessary to achieve a properly primed pipettes 130.

[0168] FIG. 6C illustrates the pipette holder 122 moved into position over a column of wells 38 in the plate 34. The pipette holder 122 is positioned so each pipette tip is aligned with a different well 38 in the column. Accordingly, each pipette 130 is associated with a particular well 38. The pipette holder 122 is lowered until each pipette tip is positioned within the mother liquor in the associated well 38. A portion of the mother liquor is aspirated from each well 38 associated with a pipette tip. The actuators then lift the pipettes 130 upward to remove the pipette tips from the wells 38. A portion of the aspirated mother liquors are then expelled from each pipette 130. The expelled mother liquors fall back into the associated well 38.

[0169] FIG. 6D illustrates the pipette holder 122 moved over the coverslip holder 124 and is positioned so each pipette tip is aligned with a different support cup 138. The support cups 138 are each holding a coverslip 144 upside down and the attachment mechanism 140 is engaged to immobilize the coverslips 144 relative to the support cups 138. One or more drops of mother liquor is expelled from each pipette 130 onto the associated coverslips 144. As a result, one more drops of the mother liquor from a particular well 38 is delivered onto a particular coverslip 144.

[0170] The drops of mother liquor are expelled onto the coverslips 144 until a desired volume of mother liquor has been delivered onto each coverslip 144. The total volume of the drops delivered onto the coverslips 144 is strictly controlled. As discussed previously, a feature of the present

invention is the ability to deliver small volumes precisely which enables small drop volumes to be used. With devices which can deliver volumes as low as 380 pL, volumes can be delivered with great precision. The precision of the volumes delivered is preferably less than about 25 nL, more preferably less than 20 nL, more preferably less than 15 nL, and most preferably less than 10 nL. The precision of the volumes delivered may also be between 380 pL and 25 nL, more preferably between 380 pL and 20 nL, more preferably between 380 pL and 15 nL, and most preferably between 380 pL and 10 nL.

[0171] FIG. 6E illustrates the pipette holder 122 returned to the rest position which was illustrated in FIG. 6A. The molecule delivery pipette 126 is moved into position over a coverslip 144. Before being moved into position over the coverslip 144, the molecule delivery pipette 126 was lowered into a particular molecule solution well and a volume of the molecule solution aspirated. Once the molecule delivery pipette 126 is in position over the coverslip 144, drops of the molecule solution are delivered onto the mother liquor which was previously delivered onto the coverslip 144. The drops of molecule solution are delivered until a desired volume of molecule solution is achieved on the coverslip 144. The precision of the volumes delivered is preferably less than about 25 nL, more preferably less than 20 nL, more preferably less than 15 nL, and most preferably less than 10 nL. The precision of the volumes delivered may also be between 2 and 25 nL, more preferably between 2 and 20 nL, more preferably between 2 and 15 nL, and most preferably between 2 and 10 nL.

[0172] The mother liquor drops and the protein drops may be delivered in any order. Once both drops are delivered, the drops combine to form a hanging drop to be studied for crystal formation.

[0173] After forming a hanging drop on the coverslip 144, the molecule delivery pipette 126 proceeds to the next coverslip 144 until a hanging drop is formed on each coverslip 144. The molecule delivery pipette 126 then returns to the position over the molecule solution well which was the source for the molecule solution used to create the hanging drops. The molecule solution remaining in the molecule delivery pipette 126 is expelled into the molecule solution well.

[0174] FIG. 6F illustrates the molecule delivery pipette 126 returned to its rest position as illustrated in FIG. 6A. FIG. 6F also illustrates the coverslip holder 124 inverted and moved into position over the column of wells 38 on the multiwell plate 34. The coverslip holder 124 is positioned so each coverslip 144 is aligned with a different well 38 in the column. Specifically, a given coverslip 144 is aligned with the well 38 which was the source of the mother liquor used to create the hanging drop on the given well 38.

[0175] The coverslip holder 124 is lowered until the coverslips 144 contact the upper edges 40 of the associated wells 38. The sealing medium which was previously applied to the upper edge 40 of the wells 38 causes a seal to be formed between the coverslips 144 and the upper edges 40 of the associated wells 38. The attachment mechanism 140 is released and the coverslip holder 124 is raised to leave each coverslip 144 in place over an associated well 38. The hanging drop hangs from the coverslips 144 into the wells 38 as illustrated in FIG. 6G.

[0176] FIG. 6H illustrates the coverslip holder 124 moved into position over the coverslip storage component 120. The coverslip holder 124 is positioned so each support cup 138 is aligned with a magazine 142 in the coverslip storage component 120. Accordingly, each support cup 138 is associated with the top coverslip 144 in each magazine 142. The coverslip holder 124 is lowered until each support cup 138 contacts a coverslip 144 within the associated magazine 142. The attachment mechanism 140 is engaged to immobilize the contacted coverslips 144 relative to the associated support cups 138.

[0177] FIG. 6I illustrates the coverslip holder 124 returned to its rest position. The top coverslip 144 from each magazine 142 discussed with respect to FIG. 6G is attached to the associated support cup 138.

[0178] The steps described with respect to FIGS. 6A-6I result in a hanging drop being formed in each well 38 of a single column of wells 38. These steps are repeated until a hanging drop is formed in the wells 38 of each column of the multiwell plate 34. Once a hanging drop is formed in each of the wells 38, the multiwell plate 34 can be moved to the next station.

[0179] The crystallization system 10 described above can be adapted to form sitting drops. This adaptation can be made with changes to the mother liquor delivery station 26 and the drop formation station 28. For instance, the mother liquor delivery station 26 is adapted to deliver mother liquor into the well regions 41 of a multiwell plate 34 adapted to perform a sitting drop array microcrystallization such as the multiwell plate 34 illustrated in FIG. 3C. Specifically, the fluid injectors 88 of the mother liquor delivery station 26 must be aligned with the well regions 41 before the mother liquor is delivered into the wells 38 of the multiwell plate 34. This alignment permits delivery of the mother liquors into the well region 41 of each well 38 without delivering the mother liquors onto the sitting drop region 42 of each well 38.

[0180] Adapting the crystallization system 10 to form sitting drops also includes adapting the drop formation station 28 to form sitting drops. The drop formation station 28 can include each of the components illustrated in FIGS. 5A-5E arranged with the same spatial relationships illustrated in FIGS. 5A-5E. However, the method of operating these components varies from the method illustrated in FIGS. 6A-6I. FIGS. 7A-7G illustrate a method for operating the drop formation station 28 to form sitting drops in each well 38 of a multiwell plate 34 adapted to perform a sitting drop array microcrystallization.

[0181] The figures are described with respect to crystallization of a protein, however, the same method can be used for crystallization of other types of molecules. FIG. 7A illustrates the drop formation station 28 in the same rest position illustrated in FIG. 6A. FIG. 7B illustrates a multiwell plate 34 adapted to perform a sitting drop array microcrystallization moved into position for sitting drop formation. Accordingly, each well 38 in the multiwell plate 34 includes a well region 41 adjacent to a sitting drop region 42. FIG. 7B also illustrates the pipette holder 122 moved into position over the wash basin 112 for priming of the pipettes. The pipettes are primed as described with respect to FIG. 6B.

[0182] FIG. 7C illustrates the pipette holder 122 moved into position over a column of wells 38 in the multiwell plate

**34.** The pipette holder **122** is positioned so each pipette tip is aligned with the well region **41** in a different well **38** in the column as illustrated in **FIG. 7D**. Accordingly, each pipette is associated with a particular well **38**. The pipette holder **122** is lowered until the tip of each pipette is positioned in the mother liquor which was previously delivered into the well region **41** of the associated well **38**. A portion of the mother liquor is aspirated from each well region **41** associated with a pipette tip. The actuators then lift the pipette upward to remove the pipette tips from the wells **38**. A portion of the aspirated mother liquors are then expelled from each pipette. The expelled mother liquors fall back into the associated well regions **41**.

**[0183]** The pipette holder **122** is then moved so each pipette tip is aligned with the sitting drop region **42** in a different well **38** in the column as illustrated in **FIG. 7E**. One or more drops of mother liquor is expelled from each pipette onto the associated sitting drop region **42**. As a result, one more drops of the mother liquor from a particular well region **41** is delivered onto the sitting drop region **42** of the same well **38**. The drops of mother liquor are expelled onto the sitting drop region **42** until a desired volume of mother liquor has been delivered onto each sitting drop region **42**. The total volume of the drops delivered onto the coverslips **144** is strictly controlled. As discussed previously, a feature of the present invention is the ability to deliver small volumes precisely which enables small drop volumes to be used. With devices which can deliver volumes as low as 380 pL, volumes can be delivered with great precision. The precision of the volumes delivered is preferably less than about 25 nL, more preferably less than 20 nL, more preferably less than 15 nL, and most preferably less than 10 nL.

**[0184]** The precision of the volumes delivered may also be between 380 pL and 25 nL, more preferably between 380 pL and 20 nL, more preferably between 380 pL and 15 nL, and most preferably between 380 pL and 10 nL.

**[0185]** **FIG. 7F** illustrates the pipette holder **122** returned to the rest position which was illustrated in **FIG. 7A**. The molecule delivery pipette **126** is moved into position over a sitting drop region **42** in a well **38** of the column. Before being moved into position over the well **38**, the molecule delivery pipette **126** was lowered into a particular molecule solution well and a volume of the molecule solution aspirated. Once the molecule delivery pipette **126** is in position over the sitting drop region **42**, drops of the molecule solution are delivered onto the mother liquor which was previously delivered onto the coverslip **144**. The drops of molecule solution are delivered until a desired volume of molecule solution is achieved on the sitting drop region **42**. The precision of the volumes delivered is preferably less than about 25 nL, more preferably less than 20 nL, more preferably less than 15 nL, and most preferably less than 10 nL. The precision of the volumes delivered may also be between 380 pL and 25 nL, more preferably between 380 pL and 20 nL, more preferably between 380 pL and 15 nL, and most preferably between 380 pL and 10 nL.

**[0186]** The mother liquor drops and the protein drops may be delivered in any order. Once both drops are delivered, the drops combine to form a sitting drop to be studied for crystal formation. **FIG. 7G** illustrates a sitting drops formed on the sitting drop region **42** of a well **38**. After forming the sitting drop on the sitting drop region **42**, the molecule delivery

pipette **126** proceeds to the sitting drop region **42** in the next well **38** until a sitting drop is formed in each well **38** of the column. The molecule delivery pipette **126** then returns to the position over the molecule solution well which was the source for the molecule solution used to create the sitting drops. The molecule solution remaining in the molecule delivery pipette **126** is expelled into the molecule solution well.

**[0187]** After formation of the sitting drop, the coverslips **144** are positioned over the wells **38** having sitting drops, new cover slips are loaded onto the coverslip holder **124** and the drop formation station **28** is returned to the rest position as described above with respect to **FIG. 6F-6I**.

**[0188]** The steps described with respect to **FIGS. 7A-7G** result in a sitting drop being formed in each well **38** of a single column of wells **38**. These steps are repeated until a hanging drop is formed in the wells **38** of each column of the multiwell plate **34**. Once a hanging drop is formed in each of the wells **38**, the multiwell plate **34** can be moved to the next station.

**[0189]** Although **FIGS. 6A-7G** illustrate a method for operating the drop formation station to form sitting drops and hanging drops, the hanging drop station be easily adapted to other crystallization techniques, other well geometries and/or other multiwell plate geometries.

**[0190]** It is noted that the apparatuses described in regard to **FIGS. 6A-7G** may optionally include one or more sensors which can detect whether mother liquor drops and/or molecule drops have been formed. An example of a suitable sensor is a LED sensor.

**[0191]** While many plate tracks **14** and transport assemblies can be used with the above stations **12**, **FIGS. 8A-8C** illustrate a preferred embodiment of a plate track **14** for transporting multiwell plates **34** between the above stations **12**. **FIGS. 8A and 8B** are sideviews of a plate track **14** looking down the longitudinal axis of the plate track **14**. The plate track **14** includes two spaced apart plate supports **158**. A pin **160** extends upward from a pin carriage **162** positioned beneath the plate track **14**. The carriage includes mechanics which can be actuated to extend the pin **160** above the plate track **14** as illustrated in **FIG. 8A** or to withdraw the pin **160** below the plate track **14** as illustrated in **FIG. 8B**.

**[0192]** **FIG. 8C** is a lateral sideview of a plate track **14** and transport assembly with a plurality of multiwell plates **34** present on the plate track **14**. The transport assembly includes a first pin carriage **162A**, a second pin carriage **162B** and a third pin carriage **162C**. Each of the pin carriages **162A**, **162B**, **162C** is configured to move along the longitudinal axis of the plate track **14** as illustrated by the arrows labeled A, B and C. The brackets at the ends of the arrows indicate the range of motion of each pin carriage **162A**, **162B**, **162C**.

**[0193]** The first pin carriage **162A** and the third pin carriage **162C** include a plurality of pins **160**. The pins are located along the pin carriage **162A**, **162C** with an approximately constant displacement between adjacent pins **160**. The pin carriage **162A**, **162C** serves to maintain the displacement between the pins **160** during movement of the pin carriage **162A**, **162C**.

[0194] Each pin 160 is illustrated in the extended position, however, the pins in one pin carriage 162 can be withdrawn while the pins 160 in another pin carriage 162 are extended. In another embodiment, a portion of the pins 160 in a single pin carriage 162 can be extended while another portion of the pins 160 within the same pin carriage 162 are withdrawn.

[0195] An air gap 166 is formed between the pin carriages 162A, 162B, 162C and each of the multiwell plates 34 positioned on the plate track 14 so the pin carriages 162A, 162B, 162C do not contact the bottom surface of the multiwell plates 34. As a result, when the pins 160 are withdrawn, the pin carriages 162A, 162B, 162C can be moved along the longitudinal axis of the plate track 14 without moving multiwell plate 34 on the plate track 14. When the pin 160 is extended and the pin carriage 162 is moved along the longitudinal axis of the plate track 14, the pin 160 pushes any multiwell plate 34 obstructing the pin's travel along the longitudinal axis of the plate track 14.

[0196] As described above, the plate transport assembly is used to transport the multiwell plates 34 from station to station along the plate track 14. Various positions along the plate track 14 can be associated with a particular station of the crystallization system 10. For instance, when a multiwell plate 34 is located at position P<sub>1</sub>, a bar code on the multiwell plate 34 can be read by a bar code station and when a multiwell plate 34 is located at position P<sub>2</sub>, a sealing medium station 22 can be used to apply a sealing medium to the upper edge 40 of the wells 38 of the multiwell plate 34. Further, when a multiwell plate 34 is positioned at P<sub>3</sub>, the multiwell plate 34 can be positioned beneath one of the delivery shuttles 74 of a mother liquor delivery station 26.

[0197] The following description describes a method for using the above transport assembly for advancing the multiwell plate 34 labeled T<sub>1</sub> from the position labeled P<sub>1</sub> to the position labeled P<sub>2</sub> to the position labeled P<sub>3</sub>. Once the multiwell plate T<sub>1</sub> is located at position P<sub>1</sub>, the pins 160 in the first pin carriage 162A are withdrawn below the plate track 14. The first pin carriage 162A is then moved to the left and the pins 160 extended above the plate track 14 as illustrated in FIG. 8C. The multiwell plate T<sub>1</sub> can then be moved from position P<sub>1</sub> to position P<sub>2</sub> by moving the first pin carriage 162A to the right until the multiwell plate T<sub>1</sub> is positioned at position P<sub>2</sub>. The pins 160 are then withdrawn below the plate track 14 and the first pin carriage 162A is moved back to its original position and the pins 160 are again extended above the plate track 14. The pins 160 in the second pin carriage 162B are withdrawn below the plate track 14 and the second pin carriage 162B is moved to the left of the multiwell plate T<sub>1</sub>. The pins 160 in the second pin carriage 162B are then extended above the plate track 14 and the second pin carriage 162B moved to the right until the multiwell plate T<sub>1</sub> is located at position P<sub>3</sub>.

[0198] The plurality of pin carriages 162 illustrated in FIG. 8C allows a multiwell plate 34 at one station to be processed through the crystallization system 10 independently of another multiwell plate 34 being processed through the crystallization system 10. For instance, a first multiwell plate 34 can be advanced from P<sub>1</sub> to P<sub>2</sub> while a second multiwell plate 34 remains in place at P<sub>3</sub>. As a result, when P<sub>1</sub>, P<sub>2</sub> and P<sub>3</sub> are each associated with different stations 12, multiwell plates 34 can be processed through different stations 12 at different rates. Further different pin carriages

162 which make up a transport assembly can be included with independent systems which are assembled together to form the system. For instance, the first pin carriage 162A and the second pin carriage 162B can be included in a mother liquor delivery system and the third pin carriage 162C can be included in a drop formation system 32.

[0199] Crystal formation can be detected by examining each drop for the formation of crystals. In a preferred embodiment, crystals are detected and graded in the various wells for crystal quality. This may be done manually or by an automated device. Diversified Scientific, Inc. of Birmingham, Alabama manufactures CRYSTALSCORE™ which may be used to automate the scoring of crystal formation.

[0200] As described above, the system can be used to performed crystallization trials where various mother liquor are screened for their ability to crystallize a protein of interest. The crystallization trials frequently include a coarse screen followed by one or more fine screens. While the mother liquors used for the fine screens are often dependent on the results of the coarse screen, the mother liquors used for the coarse screen can be standard for each crystallization trial.

[0201] When the mother liquors are used to crystallize proteins, a preferred coarse screen preferably consists of the 15 sub-screens listed in Table 1. The number of mother liquors included in each sub-screen is also listed in Table 1. The composition of the mother liquors included each of these sub-screens is listed in FIG. 9. Mother liquors having the listed compositions can be obtained from Hampton Research of Laguna Niguel, Calif.

[0202] As illustrated in Table 1, a total of 480 mother liquors are associated with the sub-screens of the preferred coarse screen. Since 480 mother liquors are included in the coarse screen and since each plate preferably includes 48 wells, the coarse screen can be performed by processing only 10 plates through the system. Further, the sub-screens generally include 24 or 48 mother liquors. Accordingly, each plate can include from one to two sub-screens.

TABLE 1

Screen	Number of mother liquors
Crystal screen I	48
Crystal screen II	48
Grid ammonium sulfate	24
Grid MPD	24
Grid sodium chloride	24
Grid PEG6000	24
Grid PEG/lithium chloride	24
Sodium/potassium phosphate	24
PEG/ion screen	48
Membrane protein screen	48
Detergent screen I	24
Detergent screen II	24
Detergent screen III	24
Cryo screen	48
Low ionic strength screen	24

[0203] Each of the mother liquors used for the coarse screen can be stored in one or more of the mother liquor storage banks. However, the number of mother liquors which may be needed for different fine screens is large enough that storage of these mother liquors impractical. Accordingly, the system can also include a station which forms the fine screen mother liquors from stock solutions



and then delivers them into the wells of a plate. Alternatively, one or more external systems can be used to create the fine screen mother liquors from stock solutions and to deliver these mother liquors into the wells of one or more plates. These plates can then be processed through the system.

[0204] When an external system is used to form and deliver fine screen mother liquors, the system control logic needs to override the mother liquor delivery station in order to avoid doubling up on the delivery of mother liquor into the wells of a plate. As a result, the system control logic must be informed when a plate which already has mother liquor is in the system. An operator can use a user interface to inform the system control logic which one of the plates already has mother liquors delivered into the wells. Alternatively, an operator use a plate having a bar code which indicates that mother liquors are already present in the wells of the plate.

#### EXAMPLE 1

[0205] The system described above was used in a plurality of lysozyme crystallization experiments where lysozyme was crystallized in a mother liquor composition including 100 mM sodium acetate and 10% sodium chloride at a pH of 4.6. The volume of the hanging drop formed by the drop formation station was different for each experiment. FIGS. 10A-10D respectively illustrate crystal formed in hanging drops of 40 nL, 100 nL, 200 nL and 1000 nL. The crystals were formed regardless of the reduction in drop size. As a result, the system can be used with submicroliter hanging drop volumes.

#### EXAMPLE 2

[0206] The system described above was used in a crystallization trial where the mother liquor for crystallizing lysozyme was optimized. During the coarse screen, 480 crystallization experiments were performed using each of the 480 mother liquors disclosed in FIG. 9. The results from each of the 480 experiments were compared to one another to identify one or more crystallization experiments yielding crystals with the most desirable characteristics. One of the identified coarse screen experiments was associated with a mother liquor composed of 30% MPD ( $\pm$ 2-methyl-2,4-pentanediol), 100 mM sodium acetate, 20 mM calcium chloride, at pH 4.6.

[0207] A fine screen consisting of 24 crystallization experiments was then performed. The composition of the mother liquors associated with each of the 24 crystallization experiments was selected relative to the composition of the mother liquor associated with the identified coarse screen experiment. The compositions of the 24 mother liquors selected for the crystallization experiments of the fine screen are listed in FIG. 11. The concentrations of certain components in each of the 24 mother liquors matched the concentration of these components in the identified coarse screen experiment. For instance, the mother liquor associated with the identified coarse screen experiment and the mother liquors for each of the fine screen crystallization experiments were all about 30% MPD and 100 mM sodium acetate. The concentrations of other components in the 24 mother liquors were varied over a range which encompassed the concentration of these same components in the identified

coarse screen experiment. For instance, the concentration of calcium chloride was 20 mM in the identified coarse screen experiment but was varied from 12.5-27.5 mM in the 24 mother liquors. Similarly, the pH was 4.6 in the identified coarse screen crystallization experiment but was varied from 4.1 to 5.1 in the 24 mother liquors.

[0208] Each of the 24 fine screen crystallization experiments were compared to one another to identify the one or more crystallization experiments yielding the most desirable characteristics.

[0209] The foregoing examples and description of preferred embodiments of the present invention are provided for the purposes of illustration and description. The examples and preferred embodiments, however, are not intended to be exhaustive or to limit the invention to the precise forms disclosed. Obviously, many modifications and variations will be apparent to practitioners skilled in this art. The embodiments were chosen and described in order to best explain the principles of the invention and its practical application, thereby enabling others skilled in the art to understand the invention for various embodiments and with various modifications as are suited to the particular use contemplated. It is intended that the scope of the invention be defined by the following claims and their equivalents.

What is claimed is:

1. A method for performing array microcrystallizations to determine suitable crystallization conditions for a molecule, the method comprising:

forming an array of microcrystallizations, each microcrystallization comprising a drop comprising a mother liquor solution whose composition varies within the array and a molecule to be crystallized, the drop having a volume of less than 1 microliter;

storing the array of microcrystallizations under conditions suitable for molecule crystals to form in the drops in the array; and

detecting molecule crystal formation in the drops by taking images of the drops.

2. The method according to claim 1 wherein taking images of the drops comprises taking a single image of each drop.

3. The method according to claim 1 wherein taking images of the drops is performed without having to adjust a focus of an optical system taking the images.

4. The method according to claim 3 wherein taking images of the drops comprises taking a single image of each drop.

5. The method according to claim 1 wherein the molecule is a macromolecule.

6. The method according to claim 1 wherein the molecule is a protein.

7. The method according to claim 1 wherein the macromolecule has a molecular weight of at least 500 daltons.

8. The method according to claim 1 wherein the drop has a volume of less than about 750 nL.

9. The method according to claim 1 wherein the drop has a volume of less than about 500 nL.

10. The method according to claim 1 wherein the drop has a volume of less than about 250 nL.

11. The method according to claim 1 wherein the drop has a volume of between about 1 nL-750 nL.

12. The method according to claim 1 wherein the drop has a volume of between about 1 nL-500 nL.

13. The method according to claim 1 wherein the drop has a volume of between about 1 nL-250 nL.

14. The method according to claim 1 wherein each microcrystallization further includes a volume of mother liquor solution separate from the drop, the mother liquor solution contained in the volume having the same composition as the mother liquor solution contained in the drop, the volume comprising less than about 500 mL of the mother liquor solution.

15. The method according to claim 1 wherein each microcrystallization further includes a volume of mother liquor solution separate from the drop, the mother liquor solution contained in the volume having the same composition as the mother liquor solution contained in the drop, the volume comprising less than about 250 mL of the mother liquor solution.

16. The method according to claim 1 wherein the mother liquor solutions have at least 4 components which are varied within the array.

17. The method according to claim 1 wherein the mother liquor solutions have at least 5 components which are varied within the array.

18. The method according to claim 1 wherein the array includes greater than 96 microcrystallizations.

19. The method according to claim 1 wherein the array includes greater than 192 microcrystallizations.

20. The method according to claim 1 wherein forming the array of microcrystallizations includes using greater than 48 stock solutions to form the mother liquor solutions used in the array.

21. The method according to claim 1 wherein forming the array of microcrystallizations includes using greater than 96 stock solutions to form the mother liquor solutions used in the array.

22. The method according to claim 1 wherein forming the array of microcrystallizations includes using greater than 192 stock solutions to form the mother liquor solutions used in the array.

23. The method according to claim 1 wherein forming the array of microcrystallizations includes forming the drops within a volume range of less than about 25 nL.

24. The method according to claim 1 wherein forming the array of microcrystallizations includes forming the drops within a volume range of less than about 20 nL.

25. The method according to claim 1 wherein forming the array of microcrystallizations includes forming the drops within a volume range of less than about 15 nL.

26. A method for performing array microcrystallizations to determine suitable crystallization conditions for a molecule, the method comprising:

forming an array of microcrystallizations, each microcrystallization comprising a hanging drop comprising a mother liquor solution whose composition varies within the array and a molecule to be crystallized, the drop having a volume of less than 1 microliter;

storing the array of microcrystallizations under conditions suitable for molecule crystals to form in the drops in the array; and

detecting molecule crystal formation in the drops by taking images of the drops.

27. The method according to claim 26 wherein taking images of the drops comprises taking a single image of each drop.

28. The method according to claim 26 wherein taking images of the drops is performed without having to adjust a focus of an optical system taking the images.

29. The method according to claim 28 wherein taking images of the drops comprises taking a single image of each drop.

30. A method for performing array microcrystallizations to determine suitable crystallization conditions for a molecule, the method comprising:

forming an array of microcrystallizations, each microcrystallization comprising a sitting drop comprising a mother liquor solution whose composition varies within the array and a molecule to be crystallized, the drop having a volume of less than 1 microliter;

storing the array of microcrystallizations under conditions suitable for molecule crystals to form in the drops in the array; and

detecting molecule crystal formation in the drops by taking images of the drops.

31. The method according to claim 30 wherein taking images of the drops comprises taking a single image of each drop.

32. The method according to claim 30 wherein taking images of the drops is performed without having to adjust a focus of an optical system taking the images.

33. The method according to claim 32 wherein taking images of the drops comprises taking a single image of each drop.

34. A method for performing array microcrystallizations to determine suitable crystallization conditions for a molecule, the method comprising: forming an array of microcrystallizations, each microcrystallization comprising a microcrystallization volume comprising a mother liquor solution whose composition varies within the array and a molecule to be crystallized, the microcrystallization volume having a volume of less than 1 microliter;

storing the array of microcrystallizations under conditions suitable for molecule crystals to form in the microcrystallization volumes; and

detecting molecule crystal formation in the microcrystallization volumes by taking images of the microcrystallization volumes.

35. The method according to claim 34 wherein taking images of the microcrystallization volumes comprises taking a single image of each microcrystallization volume.

36. The method according to claim 34 wherein taking images of the microcrystallization volumes is performed without having to adjust a focus of an optical system taking the images.

37. The method according to claim 36 wherein taking images of the microcrystallization volumes comprises taking a single image of each microcrystallization volume.

38. The method according to claim 37 wherein the molecule is a macromolecule.

39. The method according to claim 37 wherein the molecule is a protein.

40. The method according to claim 37 wherein the macromolecule has a molecular weight of at least 500 daltons.

**41.** The method according to claim 37 wherein the microcrystallization volume has a volume of less than about 750 nL.

**42.** The method according to claim 37 wherein the microcrystallization volume has a volume of less than about 500 nL.

**43.** The method according to claim 37 wherein the microcrystallization volume has a volume of less than about 250 nL.

**44.** The method according to claim 37 wherein the microcrystallization volume has a volume of between about 1 nL-750 nL.

**45.** The method according to claim 37 wherein the microcrystallization volume has a volume of between about 1 nL-500 nL.

**46.** The method according to claim 37 wherein the microcrystallization volume has a volume of between about 1 nL-250 nL.

**47.** The method according to claim 37 wherein the mother liquor solutions have at least 4 components which are varied within the array.

**48.** The method according to claim 37 wherein the mother liquor solutions have at least 5 components which are varied within the array.

**49.** The method according to claim 37 wherein the array includes greater than 96 microcrystallizations.

**50.** The method according to claim 37 wherein the array includes greater than 192 microcrystallizations.

**51.** The method according to claim 37 wherein forming the array of microcrystallizations includes using greater than 48 stock solutions to form the mother liquor solutions used in the array.

**52.** The method according to claim 37 wherein forming the array of microcrystallizations includes using greater than 96 stock solutions to form the mother liquor solutions used in the array.

**53.** The method according to claim 37 wherein forming the array of microcrystallizations includes using greater than 192 stock solutions to form the mother liquor solutions used in the array.

**54.** The method according to claim 37 wherein forming the array of microcrystallizations includes forming the microcrystallization volumes within a volume range of less than about 25 nL.

**55.** The method according to claim 37 wherein forming the array of microcrystallizations includes forming the microcrystallization volumes within a volume range of less than about 20 nL.

**56.** The method according to claim 37 wherein forming the array of microcrystallizations includes forming the microcrystallization volumes within a volume range of less than about 15 nL.

\* \* \* \* \*