

(19) World Intellectual Property Organization
International Bureau



(43) International Publication Date
11 June 2009 (11.06.2009)

PCT

(10) International Publication Number
WO 2009/073695 A1

- (51) International Patent Classification:
H01R 12/14 (2006.01) *H01R 12/30* (2006.01)
- (21) International Application Number:
PCT/US2008/085358
- (22) International Filing Date:
3 December 2008 (03.12.2008)
- (25) Filing Language: English
- (26) Publication Language: English
- (30) Priority Data:
11/999,069 4 December 2007 (04.12.2007) US
- (71) Applicant (for all designated States except US): **MOLEX INCORPORATED** [US/US]; 2222 Wellington Court, Lisle, Illinois 60532 (US).
- (72) Inventors; and
- (75) Inventors/Applicants (for US only): **PATEL, Arvind** [US/US]; 1809 Princeton Circle, Naperville, Illinois 60565 (US). **KOSTIC, Bratislav** [US/US]; 123 Columbia Avenue, Elmhurst, Illinois 60126 (US). **MCGOWAN, Daniel** [US/US]; 1924 Golden Gate Lane, Naperville, Illinois 60563 (US). **STEAD, Kenneth** [US/US]; 1881 Sapphire Lane, Aurora, Illinois 60506 (US). **DATA,**
- Mark, M. [US/US]; 213 Buli Lane, Bolingbrook, Illinois 60490 (US).
- (74) Agent: **SHELDON, Stephen, L.**; Molex Incorporated, 2222 Wellington Court, Lisle, Illinois 60532 (US).
- (81) Designated States (unless otherwise indicated, for every kind of national protection available): AE, AG, AL, AM, AO, AT, AU, AZ, BA, BB, BG, BH, BR, BW, BY, BZ, CA, CH, CN, CO, CR, CU, CZ, DE, DK, DM, DO, DZ, EC, EE, EG, ES, FI, GB, GD, GE, GH, GM, GT, HN, HR, HU, ID, IL, IN, IS, JP, KE, KG, KM, KN, KP, KR, KZ, LA, LC, LK, LR, LS, LT, LU, LY, MA, MD, ME, MG, MK, MN, MW, MX, MY, MZ, NA, NG, NI, NO, NZ, OM, PG, PH, PL, PT, RO, RS, RU, SC, SD, SE, SG, SK, SL, SM, ST, SV, SY, TJ, TM, TN, TR, TT, TZ, UA, UG, US, UZ, VC, VN, ZA, ZM, ZW.
- (84) Designated States (unless otherwise indicated, for every kind of regional protection available): ARIPO (BW, GH, GM, KE, LS, MW, MZ, NA, SD, SL, SZ, TZ, UG, ZM, ZW), Eurasian (AM, AZ, BY, KG, KZ, MD, RU, TJ, TM), European (AT, BE, BG, CH, CY, CZ, DE, DK, EE, ES, FI, FR, GB, GR, HR, HU, IE, IS, IT, LT, LU, LV, MC, MT, NL, NO, PL, PT, RO, SE, SI, SK, TR), OAPI (BF, BJ, CF, CG, CI, CM, GA, GN, GQ, GW, ML, MR, NE, SN, TD, TG).
- Published:
— with international search report

(54) Title: LOW PROFILE MODULAR ELECTRICAL CONNECTORS AND SYSTEMS

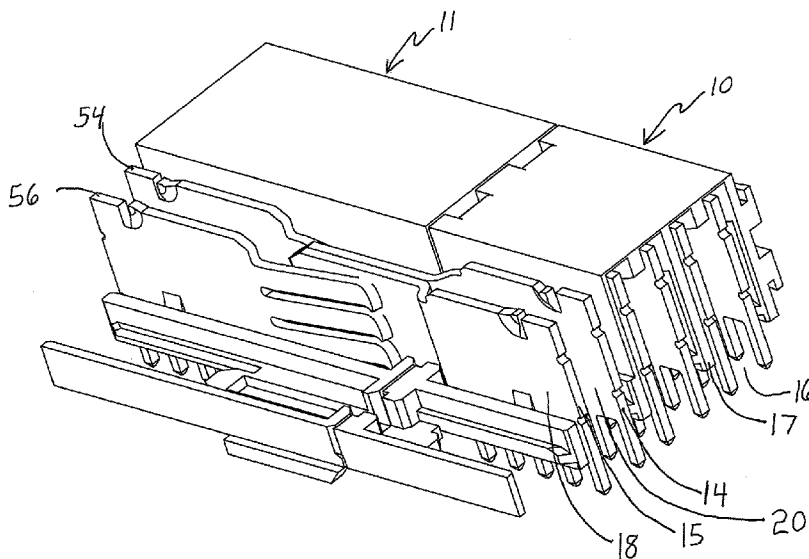

FIG. 1

(57) Abstract: Power connector modules are provided that can be plug connectors, receptacle connectors, or a system of plug and receptacle connector modules and optionally other modules, that mate together. Each connector has an uncoupled contact feature. The uncoupled contacts have exposed surfaces to dissipate heat resulting from Joule effects. The uncoupled contacts for the plug connector converge to form a blade structure at one side. The uncoupled contacts for the receptacle connector form a receiving section that engages the blade structure of the plug connector when the plug connector and receptacle connector are used together.

WO 2009/073695 A1

LOW PROFILE MODULAR ELECTRICAL CONNECTORS AND SYSTEMS

BACKGROUND OF THE INVENTION

5 The present invention generally relates to electrical power connectors that are useful as low-profile board-to-board connectors and wire-to-board connectors and that can provide excellent operation under high current density conditions and are particularly suitable for use as modular components within modular assemblies.

Description of Background Art

10 It is desired to improve power connectors such as by reducing the size of the connectors and the space they take when connected, for example, to the surface of a board component such as to a printed circuit board (PCB). Increasing current density can contribute to reducing the size of a power connector, but heat generated by the Joule effect can have negative effects. The heat can cause a temperature rise of the contacts that
15 adversely affects electrical characteristics and expands the contacts. With temperature cycling over time, the expansion effects can lead to loosened contacts or other metal components such as connector screws. There is an overall need to improve power connectors by decreasing size without requiring power reduction while addressing undesired temperature affects.

20 Prior art approaches include U.S. Patent No. 4,845,589, which relates to bus bar connectors and addresses undesired effects due to temperature cycling owing to heat generation. The patent describes an electrical power connector having two exposed sidewalls that merge with a support structure to form a U-shaped structure. Extending from the two exposed sidewalls are spring contact arms that mate with a bus bar. A sliding structure is
25 provided with the objectives of allowing easy access to the power connector and correcting problems resulting from temperature cycling. U.S. Patent No. 5,618,187 pertains to a bus bar contact for mounting on a circuit board comprising a U-shaped center section, contact fingers, termination posts and stabilizing tabs. The U-shaped center section of the bus bar contact has two exposed parallel panels. U.S. Patent No. 6,666,698 describes air gaps
30 between terminals that are susceptible to arcing. The patent describes mechanical means which is said to impart higher mating and unmating velocities to diminish arcing in high volt

systems. U.S. Patent No. 6,930,889 relates to a circuit board and a slot connector assembly. The patent describes a circuit board comprised of a substrate and electrical contacts wherein the electrical contacts mate with contact springs of a slot connector.

Other prior art includes the following. U.S. Patent No. 6,319,075 pertains to
5 electrical connectors and more particularly to electrical power connectors said to be useful in circuit board or backplane interconnection systems. This patent describes electrical terminals comprising a pair of spaced apart planar walls having a bridging structure extending between and joining the walls. The bridging structure has forward and rearward bridging elements or a bridging element having an open upper section for heat dissipation. U.S. Patent No.
10 6,780,027 relates to electrical connectors for transmitting electrical power. This patent is directed to an electrical connector having both an aperture for engagement with a complementary contact and a protruding tab for engagement with an AC cable plug. U.S. Patent No. 6,848,950 is directed to power contacts employed in electrical connectors that transmit electrical power. The patent describes two-piece electrical contacts having three
15 electrical interfaces. One electrical interface uses the walls of the two pieces to mate with an electrical connector; another interface has terminals or tails extending from the contact to engage a circuit board; and a third interface is a plug projection for engaging a cable plug. The patent further describes an electrical connector comprising a first power contact providing both a cable-to-board interface and a board-to-board interface. This patent also
20 describes an electrical connector having a power contact with a first wall and a second wall wherein the first wall and the second wall are coupled. The electrical connector also has a second power contact with a third wall and a fourth wall wherein the third wall and the fourth wall are uncoupled. U.S. Patent No. 6,848,953 describes an electrical connector, particularly electrical power connectors said to be useful in circuit board or backplane interconnectors.
25 The patent discusses a contact with two opposing sidewalls having a bridge extending between the sidewalls and a clip extending from the bridge for engaging the arm of a bus bar.

The following patents describe other prior art proposals. U.S. Patent No. 6,869,294 pertains to matable electrical connectors having power capabilities. The patent discloses a plug connector having a substantially U-shaped electrically conductive body. Three open
30 sides and three closed sides define the body. The three closed sides comprise two side walls and an upper bridging element. U.S. Patent No. 6,890,221 pertains to a matable electrical

connector in a housing. This approach requires a receptacle connector comprising a pair of spaced receptacle contact walls and a plug connector comprised of a pair of spaced plug contact walls wherein both the receptacle connector and the plug connector are in the same housing. U.S. Patent No. 7,059,919 pertains to an electrical connector, particularly electrical power connectors said to be useful in circuit board or backplane interconnectors. The patent discusses a pair of flexible beams that extend from a pair of opposed contact side walls. The flexible beams are widthwise tapered in a direction from which the beams extend. The flexible beams also extend outwardly away from each other and inwardly towards each other. An unobstructed heat flow path is defined between the flexible beams. U.S. Patent No. 7,070,464 pertains to electrical connectors, particularly electrical power connectors said to be useful in circuit board or backplane interconnectors. The patent describes a pair of opposed contact walls having a bridging element adjoining the opposed contact walls. The patent discusses two opposed contact walls each having panels and flexible beams extending from the panels. The flexible beams extend outwardly away from each other and inwardly toward each other.

Prior art including some of that discussed hereinabove describes power connectors that use coupled contacts wherein a cumbersome and restrictive bridging element connects two contacts. The bridging elements take up space, restrict air flow and hinder flexible use of contacts. The power connector of this invention employing uncoupled contacts has a low profile but sufficient height to provide good air flow within the connectors. The power connectors as described herein have low profiles with only slight or moderate temperature rise during extended use. Advantageously, board space is saved, the power connectors providing about 30 to about 60 amps per blade and typically about 45 to about 55 amps per blade, equating to between about 120 and about 300 amps per inch and typically between about 180 and about 275 amps per inch.

With the present approach, it has been determined that various characteristics of prior art such as these patents may have shortcomings such as these and undesirable attributes, results or effects. The present approach recognizes and addresses matters such as these to provide enhancements not heretofore available. Overall, the present approach more fully meets the persistent need for smaller power connectors to accommodate more power with limited temperature rise and limited space requirements.

SUMMARY OF THE INVENTION

One aspect or embodiment of the invention relates to improved power connectors that have an insulative housing. These housed power connectors have improved and lower profiles, typically 30% less than commercial housed power connectors with similar power performance. The improved power connectors can include plug connectors and receptacle connectors for mating with each other or other components. The power connector, the receptacle connector or both may comprise two uncoupled contacts seated in cavities in the housing. The contacts have exposed surfaces to dissipate heat resulting from Joule effects, and the cavities are constructed with openings and/or spacings to improve air flow in one or more of the top, bottom, bottom and/or rear of the connector cavities. Improved airflow permits higher current density without unacceptable temperature rise and contributes to providing power connectors that have a low profile with no sacrifice of quality or power handling capabilities.

In another aspect or embodiment, the use of uncoupled walls eliminates a bridging structure that is used in some prior art approaches to couple and hold two contact walls in position relative to one another. The bridging structure typically needs space on the top side of the contact walls adding to the connector height and profile. Eliminating the space required when a bridging structure is included contributes to a lower connector profile.

According to another aspect or embodiment, the uncoupled contacts can employ small barbs on the sides of the contacts to assist in holding the contacts in place. According to one approach, a barb is positioned on a side, such as near the bottom of a contact to ride on a shoulder of the housing and lock in the contact vertically. According to another approach, a barb near the top of a contact locks the contact into a housing channel to lock in the contact horizontally. Each barb adds little if anything to connector profile. Typically both barb arrangements will be used to provide secure positioning in two dimensions.

According to a further aspect or embodiment, the mating sections of the contacts for the plug connector form a blade structure, and the mating sections of the contacts for the receptacle connector typically have multiple contact beams for parallel path current flow to minimize resistance and heat generation in order to aid in employing higher current densities.

The multiple contact beams form a receiving section that has camming portions for blade entrance and restriction portions for tight blade contact.

In accordance with another aspect or embodiment, and for ease of mating and facilitating of modular assemblies, one mating connector can have guide posts and the other mating connector can have guide apertures to receive the guide posts. The guide posts and apertures can be placed on top of the connectors which typically preserves board space or can be placed the side of the connectors for enhanced air flow.

10

BRIEF DESCRIPTION OF THE DRAWINGS

Figure 1 is a perspective view, partially broken away, of an embodiment of a plug connector coupled to a receptacle connector;

Figure 1A is a perspective view of a contact pair of the plug connector shown in Figure 1;

Figure 1B is a side elevational view of a contact as in Figure 1A;

Figure 2 is a perspective view of another embodiment of a plug contact having two uncoupled plug contact members;

Figure 3 is a detailed perspective view of the plug connector of Figure 1, shown connected with a printed circuit board;

Figure 4 is a detailed elevational view of the plug connector of Figure 1, showing engagement and spacing between the contact and components of the housing;

Figure 5 is a perspective view of a plug connector and of an embodiment of a receptacle connector, partially broken away, such as shown in Figure 1;

Figure 5A is a perspective view of an embodiment of an uncoupled receptacle contact pair;

Figure 5B is a side elevational view of a receptacle contact member of the contact pair as in Figure 5;

Figure 5C is a top plan view of an uncoupled receptacle contact pair as in Figure 5;

Figure 6 is a perspective view or another embodiment of a receptacle contact pair, showing two uncoupled receptacle contact members;

Figure 7 is a perspective view of a plug connector having a plurality of plug contacts in an insulative housing;

Figure 7A is a perspective view, partially broken away, of the edges of plug contacts in insulative housing;

5 Figure 8 is a perspective view of a plug connector and of a receptacle connector with receptacle contacts in insulative housing, partially broken away, the receptacle contacts shown in engagement with blades of the plug connector;

Figure 8A is a perspective view of the receptacle connector of Figure 8, rotated 180 degrees, showing receptacle contacts in an insulative receptacle housing;

10 Figure 8B is a perspective view of embodiments of contacts shown in a mated configuration, with the respective housings being removed to provide more detailed views of uncoupled panels in both contacts seen in Figure 8;

Figure 9 is a perspective view of an embodiment including an assembly of various modular components including a plug connector and a receptacle connector connected to a printed circuit board;

Figure 10 is another, differently oriented perspective view of the assembly embodiment illustrated in Figure 9;

Figure 11 is an exploded perspective view of another orientation of the assembly embodiment illustrated in Figure 9;

20 Figure 12 is a perspective view of one of the exploded assemblies of Figure 11, at another different orientation;

Figure 13 is a perspective view of two modules from Figure 9, illustrating a dovetail assembly embodiment;

25 Figure 14 is another perspective view of an embodiment of modular components as generally shown in Figure 13;

Figure 15 is a perspective view of another embodiment including a modular receptacle connector assembly coupled to a modular plug connector assembly;

Figure 16 is a side elevation view of the modular receptacle connector assembly shown in Figure 15; and

30 Figure 17 is a top plan view of another embodiment of a modular receptacle connector assembly.

DETAILED DESCRIPTION OF THE ILLUSTRATED EMBODIMENTS

As required, detailed embodiments of the present invention are disclosed herein; however, it is to be understood that the disclosed embodiments are merely exemplary of the invention, which may be embodied in various forms. Therefore, specific details disclosed
5 herein are not to be interpreted as limiting, but merely as a basis for the claims and as a representative basis for teaching one skilled in the art to variously employ the present invention in virtually any appropriate manner.

Figure 1 illustrates a plug connector, generally designated at 10, and a receptacle connector, generally designated at 11. These are suitable for use as power connector
10 components. The term power connector is meant to encompass AC power connectors and/or DC power connectors. The plug connector 10 illustrated in Figure 1 includes a contact, generally designated at 13, comprising a pair of uncoupled contact members, generally designated at 14 and 15. The contact 13 is held in place by a plug connector insulative housing 17, cut away at some of the contacts shown in this Figure 1. Contact members 14
15 and 15 have back panels or body panels 18 and 20, respectively. Panels 18 and 20 are substantially parallel to each other and form a medial space 16 between them. As seen in Figures 1, 1A and 1B, extending from the bottom of back panels 18 and 20 are tails 22, 24, 26, 28 and 30 and tails 32, 34, 36, 38 and 40, respectively, for insertion into a printed circuit board (PCB) 148 (Figure 3). After insertion, the tails may be soldered in place.

20 Also extending from back panels or body panels 18 and 20 are beams 42 and 44, respectively. In some embodiments, such as shown in Figures 1, 1A and 1B, beams 42 and 44 extend from sides of the panels 18 and 20 that are orthogonal to the sides of panels 18 and 20 from which the tails extend. The tails in this embodiment are typically solder tails and compliant tails. In other embodiments such as the one shown in Figure 2, where a contact
25 13a is shown, there are uncoupled contact members 14a and 15a. These contact members include back or body panels 18a and 20a, which have tails 21, 23, 25 and 27 and tails 31, 33, 35 and 37, respectively, that extend from these back panels in a direction generally opposite to or in line with the respective beams 42 and 44. The tails in this embodiment typically are solder tails and compliant tails.

30 Whether the tails are oriented generally orthogonal or generally in line with the beams and blade formed therefrom, the blade extends from back panel or body panel pairs or

contact members 18, 20 or 18a, 20a. Viewed in the direction out of the plug connector, and toward the receptacle connector (or outwardly), beams 42 and 44 extend from the back or body panels first in an inward direction toward each other until they meet, and then they are parallel to each other, typically in contact with each other along this length. The outwardly extending section of the beams 42 and 44 form blade 46, which is the mating portion of the contacts 13 of the plug connector 10. As seen in Figures 3 and 4, described in greater detail hereinafter, barbs 117 and 120 can be provided to cooperate with members of the housing such as housing shoulders or projections 118, to maintain the contact members 14, 15 in place and/or to provide housing channel 116 or open volume 119 along a face of a contact member.

Receptacle connector, generally designated at 11 in Figure 1 and with its housing removed in Figure 5, has contacts, generally designated at 47, each having two spaced apart uncoupled contact members 48 and 50 forming a medial space 52 between contact members 48 and 50. Contact members 48 and 50 have back panels or body panels 54 and 56, respectively, that are substantially parallel to each other. Extending from the bottom of panels 54 and 56 are tails 57, 59, 61, 63 and 65 and tails 66, 68, 70, 72 and 74, respectively, for insertion into a PCB. After insertion, the tails may be soldered in place. Also extending from panels 54 and 56 are beams 76, 78 and 80 and beams 82, 84 and 86, respectively.

In some embodiments, such as shown in Figures 5, 5A and 5B, beams 76, 78 and 80 and beams 82, 84 and 86 extend from respective edges of the back panels or body panels 54 and 56 that are orthogonal to the edges of panels 54 and 56 from which the tails extend. The tails of this embodiment typically are solder tails or compliant tails. This orthogonal relative orientation of the beams and tails is used for parallel board connection. In other embodiments, such as shown in Figure 6, a contact is provided, generally designated as contact 47a, the beams 76, 78 and 80 and beams 82, 84 and 86 extend from respective edges of panels 54 and 56 that are opposite of the edges of panels 54 and 56 from which tails 67, 69 and 71, and tails 58, 60 and 62 extend, respectively. The tails in this embodiment are typically solder tails or compliant tails. This opposing relative orientation of the beams and tails is used for perpendicular board connection, where one board can be considered a horizontal board and the other a vertical board.

Whether the tails are oriented generally orthogonal or generally in line with the beams, the beams extend from the back panels or body panels 54, 56. When considering the combination of plug connector and receptor connector, and viewed in the direction out of the receptacle connector 11 and toward the plug connector 10 (or inwardly), beams 76, 78 and 80 and beams 82, 84 and 86 first extend from the respective panels 54 and 56 inwardly toward the opposing beam of the opposing contact and then outwardly away from the opposing beam. The sections of the opposing beams that extend outwardly form camming surfaces 88 and 90 first contact a plug connector during mating. In an illustrated embodiment, the camming surfaces 88, 90 engage blade 46 of the plug connector 10. Proper mating action proceeds, with the camming surfaces helping to guide blade 46 to enter receptacle connector 11. Thereafter, the blade 46 encounters restriction portions 92 and 94 of beams 80 and 86, respectively. Substantially simultaneously, like restriction portions of beams 76, 78 and 82, 84 respectively are encountered by the blade 46. This mating typically is completed when opposing surfaces of the plug connector 10 and receptacle connector 11 contact each other to stop any further movement of the plug connector and/or receptacle connector toward each other.

Referring to Figures 7 and 7A, plug connector 10 includes insulative plug housing 96 that has a top wall 100, a front wall 102 and side walls 104. Housing 96 also has one or more tunnel like cavities 98 that extend through the back and bottom of housing 96 and extend close to but not through top wall 100, front wall 102 and sidewall 104. Front wall 102 has aperture 106 at each section that is large enough for blade 46 to pass through. Front wall 102 also has two smaller apertures 108 at each section that allow for probes to be inserted into housing 96. Front wall 102 in addition has an indentation 110 at each section that extends from top to bottom and forms a top aperture 112 and a bottom aperture 114 therealong. A housing channel 116 and a housing shoulder or projection 118 in housing 96 assist in positioning each pair of contact members 14 and 15. Contact members 14 and 15 are spaced apart from side walls of cavities 98. In this illustrated plug connector embodiment, a side barb or projecting member 117 on one or both of contact members 14 and 15 is shown, for example in Figure 3, toward the bottom of the panels riding on housing shoulder 118 to lock contact members 14 and 15 vertically while providing air space around the contact members. Contact members 14 and 15 are positioned slightly above a board component such as PCB

148 shown in Figure 3 when in use to assist in providing a slight spacing 150 from the PCB or the like. Such spacing assists with proper solder flow while also providing air volume for heat dissipation and typically is facilitated by providing standoffs 115.

This illustrated plug connector embodiment also provides a barb or a projecting member 120 on each or both of contact members 14 and 15, as shown for example in Figure 1A. Each such barb or member 120 fits within housing channel 116 and engages wall 121 (Figure 4) of housing 17 to prevent horizontal movement of contact members 14 and 15 within the connector housing 96. Maintaining proper positioning helps to assure correct alignment and air space around the contact members, and same can contribute to reducing size requirements. When tails are soldered in place, such as onto a board connector such as PCB 148, the housing shoulders and the housing channels can be positioned such that housing 96 is positioned slightly above the PCB so there exists a slight space between housing 96 and the PCB, typically with the assistance of the standoff 115 as noted herein.

Referring to Figures 8 and 8A, receptacle connector 11 has insulative receptacle housing, generally designated at 122, that has a top wall 124, a front wall 126 and side walls 128. Housing 122 also has one or more tunnel like cavities 130, typically one at each section, that extend through the back and bottom of housing 122 and extend close to but not through top wall 124, front wall 126 and side walls 128. Front wall 126 has aperture 132 at each section just large enough for blade 46 from plug connector 10 and only minimal air to pass through. Housing channel or top slots 134 and housing shoulder or projection 136 position contact members 48 and 50 in each section of housing 122. Contacts 47 comprised of contact members 48 and 50 are spaced apart from side walls of cavities 130 at each section. Barbs 137 are shown in this illustrated embodiment on contact members 48 and 50, as shown in Figure 8B, ride on housing shoulder 136 and lock contact members 48 and 50 vertically. Contact members 48 and 50 are positioned slightly above the PCB when in use to assist in providing clearance from the PCB. Such typically is facilitated by including at least one standoff 139.

This illustrated receptacle connector embodiment also provides a barb 138 in one or each of contact members 48 and 50 that fits within housing channel 134 at each section to prevent horizontal movement of contact members 48 and 50 within housing 122, while providing air space around the contact members 48 and 50. When tails are soldered in place,

the contact barbs, the housing shoulders and the housing channels can be positioned such that housing 122 is positioned slightly above the PCB 148 so there exists a slight space between housing 122 and the PCB. Figure 8B shows a typical mating engagement between plug contact 13 and receptacle contact 47 and provides an unobstructed view of an embodiment of these components.

Referring to Figure 9, a plug connector 10 and a receptacle connector 11, shown in a power connector assembly 152, can be used in a modular manner by placing complementary interlocking connectors such as interlocking dove tails 140 and 142 on respective outer sides of the plug housing and on respective outer sides of the receptacle housing. This modular housing approach provides product flexibility with ease of manufacturing and low tooling cost. If desired, signal connectors, generally designated as 154, 156, can be in the same assembly as the power contacts by providing signal modules and by interconnecting such signal modules with a power module, such as by incorporating dovetails 140, 140a, 142 and 142a (Figures 10, 13, 14). Multiple signal modules and power modules can be assembled to provide a power connector assembly, with or without signal modules.

As seen in Figure 10 for example, guide posts 144 on the housing of the plug connector 10 and guide post receptors 146 on the housing of the receptacle connector 11 may optionally be used for ease of mating. One or more guide posts can be added with corresponding guide post receptors to further aid in alignment and mating. Typically the guide post and post receptors system will incorporate dovetails 140a and 142a. When the guide posts and receptors are added to the tops of modules, this helps to preserve board space such as by minimizing width. When the guide posts and receptors are positioned on the sides of modules, better air flow can be realized.

Electrical current flows through a plug connector 10 and/or a receptacle connector 11 when it is put into use, typically as mated together, heat is generated due to the Joule effect. The generated heat, if not dissipated, can cause temperature rise and limit current flow because only limited temperature rise can be tolerated. A cross flow of air over the exposed surfaces of the contact members 14 and 15 and/or 48 and 50 for example will dissipate the generated heat and limit temperature rise. Air can enter the cavities 98 and/or 130 through their rear openings and pass over the contacts such as 14, 15 and/or 48 and 50. Air also will exit from rear openings of the cavities 98 and/or 130. In addition, some air will escape from

the apertures 112 and/or 114 in the top and bottom walls of the plug cavities thus dissipating heat. When assembled onto a board component such as a PCB, a slight airspace or clearance between contacts 14 and 15 and/or 48 and 50 and the PCB to which they are connected and a slight airspace or clearance between housing 96 and/or housing 122 and the PCB to which they are connected can aid in improving airflow. Heat dissipation is further realized by the uncoupled contact member pairs that are provided by the present structure, especially when the uncoupled characteristic is combined with open volumes that are provided on the faces of the contact members that are opposite of the opposing uncoupled faces of those same contact members that define the medial space. In this way, each contact member face is directly engaged by minimal solid matter, leaving additional open air volume for heat dissipation.

Figure 15 represents a modular connector system, generally designated as 210, that comprises a modular receptacle connector assembly, generally designated as 211, and a modular plug connector assembly, generally designated as 212. Modular plug assembly 212 is shown connecting PCB or mother board 215, considered horizontal, to PCB or daughter board 217, considered to be vertical. Modular connector system 210 is thus shown as one modular piece that connects two PCBs at a right angle.

In an embodiment, Figure 16 illustrates receptacle connector assembly 211 comprised of three interconnected modules, power receptacle module for DC input power, generally designated as 221, receptacle module for electrical signal, generally designated as 223, and receptacle module for DC ground return, generally designated as 225. DC power receptacle module 221 has insulative housing 208. DC power receptacle module 221 has a plurality of cavities 228 in housing 208 to seat DC power receptacle contacts 230 (Figure 16).

DC power input of power receptacle module 221 as shown in Figure 16 suitably comprises one set of contacts to provide one DC power supply. Said DC power supply provides between about 500 and about 2200 watts and typically between about 800 and about 1500 watts, with the current divided substantially equally over the input contacts. Suitably the DC receptacle contacts have a pitch of about 6.0 mm.

Signal module 223 has insulative housing 164 and suitably contains between about 6 and about 40 mated signal contacts and typically between about 18 and about 32 signal receptacle contacts 166. Side 170 of signal receptacle housing 164 interconnects to side 172 of power input receptacle housing 208, as shown in Figure 16. Side 170 and side 172 have

mating dove tail members 174 and 176. This modular housing approach provides product flexibility with ease of manufacturing and low tooling cost. Secondary interlocking features such as clips 178 (Figure 16) at the bottom of the module 223 are also employed to aid in proper alignment of the modules and increase the strength of the interlock. All side by side aligned modules in modular connector system 210 may be interlocked employing these features.

DC ground return receptacle module 225 (Figure 16) has insulative housing 180 with cavities 181 for seating DC ground receptacle contacts 182. These DC ground receptacle contacts transmit ground power return of about 500 to about 2200 watts and typically between about 800 and about 1500 watts, and the current is divided substantially equally among the ground receptacle contacts. Opposite the mating portion of the ground return receptacle contacts, the contacts have a plurality of compliant pins for insertion into a board considered to be vertical. DC power input receptacle contacts 230 and DC ground return receptacle contacts 182 align substantially in a row.

As shown in Figure 15 and 17, DC power plug module 214 has insulative housing 234 with cavities 235 to seat DC power plug contacts 236. Electrical signal plug module 216 has signal plug housing 248 that incorporates between about 6 and about 40 mated signal contacts and typically between about 18 and about 32 signal contacts. DC ground module 218 has insulative housing 252 with cavities 254 to seat DC ground plug contacts 256.

Guide posts 264 and 266 (Figure 17) on the housing of the plug modules 214 and 218, respectively, and guide post receptors 268 and 270 (Figure 16) on the housing of the receptacle modules 221 and 225, respectively, may optionally be used for ease of mating. One or more guide posts can be added with corresponding guide post receptors to further aid in alignment and mating. When the guide posts and receptors are added to the tops of modules, this helps to preserve board space such as by minimizing width.

In another aspect or embodiment, modular connector system 210 shown in Figure 15 has a height of between about 12 and about 25 mm off the board and typically between about 18 and about 22 mm off the board.

It will be understood that there are numerous modifications of the illustrated embodiments described above which will be readily apparent to one skilled in the art, such as many variations and modifications of the power connector and/or its components including

combinations of features disclosed herein that are individually disclosed or claimed herein, explicitly including additional combinations of such features, or alternatively other types of power connectors. Also, there are many possible variations in the materials and configurations. These modifications and/or combinations fall within the art to which this
5 invention relates and are intended to be within the scope of the claims which follow.

CLAIMS

1. A power connector combination system comprising:

at least one plug connector module having an insulative housing and at least one
5 contact located at least partially within the housing, said contact having a pair of contact
members having a blade portion and a panel portion, said plug connector contact is seated in
the plug connector housing;

said panel portion of the plug connector contact has a pair of uncoupled contact
panels that define a medial space therebetween, said plug connector contact panels each have
10 a plurality of uncoupled sides, and at least one of said contact panels has at least one tail
extending therefrom;

at least one receptacle connector module having an insulative housing and at least one
contact located at least partially within said housing, said receptacle contact comprising a
pair of opposing contact members, said pair of opposing contact members are seated in the
15 receptacle connector housing; and

said contact members of the receptacle connector are substantially parallel uncoupled
contacts that define a medial space therebetween, and at least one tail extends from a tail side
thereof.

20 2. The power connector system of claim 1, wherein said uncoupled side having
at least one extending tail and said converging side are selected from the group consisting of
being substantially opposite each other and substantially orthogonal to each other.

25 3. The power connector system of claim 1, wherein said receptor side of the
contact member and the tail side of the contact member are selected from the group
consisting of being substantially opposite each other and substantially orthogonal to each
other.

30 4. The power connector system of claim 1, wherein the plug connector housing
has a plug cavity that extends through a back wall and a bottom wall of the plug connector

housing and extends close to but not through a top wall, a front wall and a side wall of the plug connector housing and seats the plug contacts.

5 5. The power connector system of claim 4, wherein the plug connector cavity has a housing channel, the plug contact has an upper barb, and the upper barb fits within the housing channel to seat the contact horizontally.

10 6. The power connector system of claim 4, wherein the plug connector cavity has a housing shoulder, the plug contact has a lower barb, and the lower barb rides on the housing shoulder to seat the contact vertically.

15 7. The power connector system of claim 1, wherein the plug connector housing and the receptacle connector housing each includes a standoff that engages a surface of a board component such that there is a space between the contacts and the surface of the board component.

20 8. The power connector system of claim 1, wherein the plug connector housing and the receptacle connector housing each includes a standoff that engages a surface of a board component, said tail is soldered to the board component, and said plug connector housing is positioned above the surface to which the tails are soldered such that there exists a space between the housing and the surface.

25 9. The power connector system of claim 4, wherein a front wall of the plug connector housing cavity has an aperture large enough for the plug blade to pass through.

30 10. The power connector system of claim 1, wherein the receptacle housing has a receptacle cavity that extends through a back wall and a bottom wall of the receptacle housing and extends close to but not through a top wall, a front wall and a side wall of the receptacle housing and seats the receptor contacts.

11. The power connector system of claim 10, wherein the receptacle cavity has a housing channel, the receptacle contact has an upper barb, and the upper barb fits within the housing channel to seat the contact horizontally.

5 12. The power connector system of claim 10, wherein the receptacle connector cavity has a housing shoulder, the receptacle contact has a lower barb, and the lower barb rides on the housing shoulder to seat the contacts vertically.

10 13. The power connector system of claim 11, wherein a front wall of the receptacle cavity has an aperture large enough for the plug blade to pass through.

14. The power connector system of claim 1, wherein the connector further comprises a first signal housing having signal contacts, the first signal housing interconnected to the plug housing and a second signal housing having signal contacts, the second signal housing interconnected to the receptacle housing and wherein the signal contacts in the first signal housing are matable with the signal contacts in the second signal housing.

15 20 15. The power connector system of claim 1, wherein at least some of the housings are interconnected with dove tail interconnectors positioned on the sides of the housings.

16. The power connector system of claim 14, wherein the housings are interconnected with dovetail interconnectors positioned on the sides of the housings.

25 17. The power connector system of claim 1, wherein a first plug connector and a first receptacle connector transmit AC power and a second plug connector and a second receptacle connector transmit DC power.

18. The power connector system of claim 17, wherein the first housings are interconnected with dovetail interconnectors positioned on the sides of the first housings and

the second housings are interconnected with dove tail interconnectors positioned on the sides of the second housings.

19. The power connector system of claim 1, further including at least one guide
5 post module engaging at least one of said plug connector or receptacle connector modules, at least one guide post receptor module engaging at least one of said plug connector or receptacle connector modules, and a portion of said guide post module enters said guide post receptor module.

10 20. A plug connector comprising:
an insulative plug connector housing and at least one plug contact located at least partially within the insulative plug housing, said contact having a pair of contact members having a blade portion and a panel portion, said plug connector contact is seated in the plug connector housing;

15 said panel portion of the plug connector contact has a pair of uncoupled contact panels that define a medial space therebetween;

the uncoupled contact panels of the plug connector are in substantially parallel planes and have a converging side from which said blade portion extends; and

20 said contact panels each have a plurality of uncoupled sides, and at least one of said contact panels has at least one tail extending therefrom.

21. The plug connector of claim 20, wherein said uncoupled side having an extending tail and said converging side are substantially opposite each other.

25 22. The plug connector of claim 20, wherein said uncoupled side having an extending tail and said converging side are substantially orthogonal to each other.

30 23. The plug connector of claim 20, wherein the plug connector housing has a plug cavity that extends through a back wall and a bottom wall of the plug connector housing and extends close to but not through a top wall, a front wall and a side wall of the plug connector housing and seats the plug contacts.

24. The plug connector of claim 20, wherein the plug connector cavity has a housing channel, the plug contact has an upper barb, and the upper barb fits within the housing channel to seat the contact horizontally.

5

25. The plug connector of claim 20, wherein the plug connector cavity has a housing shoulder, the plug contact has a lower barb, and the lower barb rides on the housing shoulder to seat the contact vertically.

10

26. The plug connector of claim 20, wherein the plug connector housing includes a standoff that engages a surface of a board component such that there is a space between the contacts and the surface of the board component.

15

27. The plug connector of claim 20, wherein the plug connector housing includes a standoff that engages a surface of a board component, said tail is soldered to the board component, and said plug connector housing is positioned above the surface to which the tails are soldered such that there exits a space between the housing and the surface.

20

28. The plug connector of claim 23, wherein a front wall of the plug cavity has an aperture large enough for the plug blade to pass through.

25

29. A receptacle connector comprising:

an insulative receptacle connector housing having at least one contact located at least partially within said housing, said receptacle contact comprising a pair of opposing contact members that are seated in the receptacle connector housing;

said contact members of the receptacle connector are uncoupled contacts that define a medial space therebetween;

the contact members of the receptacle connector are substantially parallel; and

30

each contact member includes at least one beam, and each said beam extends from a receptor side thereof and at least one tail extends from a tail side thereof.

30. The receptacle connector of claim 29, wherein said receptor side of the contact member and the tail side of the contact member are substantially opposite each other.

5 31. The receptacle connector of claim 29, wherein said receptor side of the contact member and the tail side of the contact member are substantially orthogonal to each other.

10 32. The receptacle connector of claim 29, wherein at least one of said beams of the receptacle connector contact first extends from the receptor side inwardly towards the opposing beam on the opposing contact and then outwardly forming a camming surface at a remote portion of the beam.

15 33. The receptacle connector of claim 32, wherein a restrictor portion is formed between opposing beams of the receptacle connector contact, the opposing beams extend inwardly toward each other, and the restrictor portion is between the remote portion of the beam and the receptor side of the receptacle connector contact member.

20 34. The receptacle connector of claim 29, wherein each contact member of the receptacle connector includes a plurality of opposing pairs of the beams, and each of said beam pairs comprises opposing beams that form a restrictor portion adapted to matingly receive the blade portion of the plug connector.

25 35. The receptacle connector of claim 29, wherein the receptacle housing has a receptacle cavity that extends through a back wall and a bottom wall of the receptacle housing and extends close to but not through a top wall, a front wall and a side wall of the receptacle housing and seats the receptacle contacts.

30 36. The receptacle connector of claim 35, wherein the receptacle cavity has a housing channel, the receptacle contact has an upper barb, and the upper barb fits within the housing channel to seat the contact horizontally.

37. The receptacle connector of claim 35, wherein the receptacle cavity has a housing shoulder, the receptacle contact has a lower barb, and the lower barb rides on the housing shoulder to seat the contacts vertically.

5 38. The receptacle connector of claim 29, wherein the receptacle housing includes a standoff that engages a surface of a board component such that there is a space between the contacts and the surface of the board component.

10 39. The receptacle connector of claim 29, wherein the receptacle housing includes a standoff that engages a surface of a board component, said tail is soldered to the board component, and said receptacle housing is positioned above the surface to which the tails are soldered such that there exits a space between the housing and the surface of the board component.

15 40. The receptacle connector of claim 35, wherein a front wall of the receptacle cavity has an aperture large enough for a plug blade to pass through.

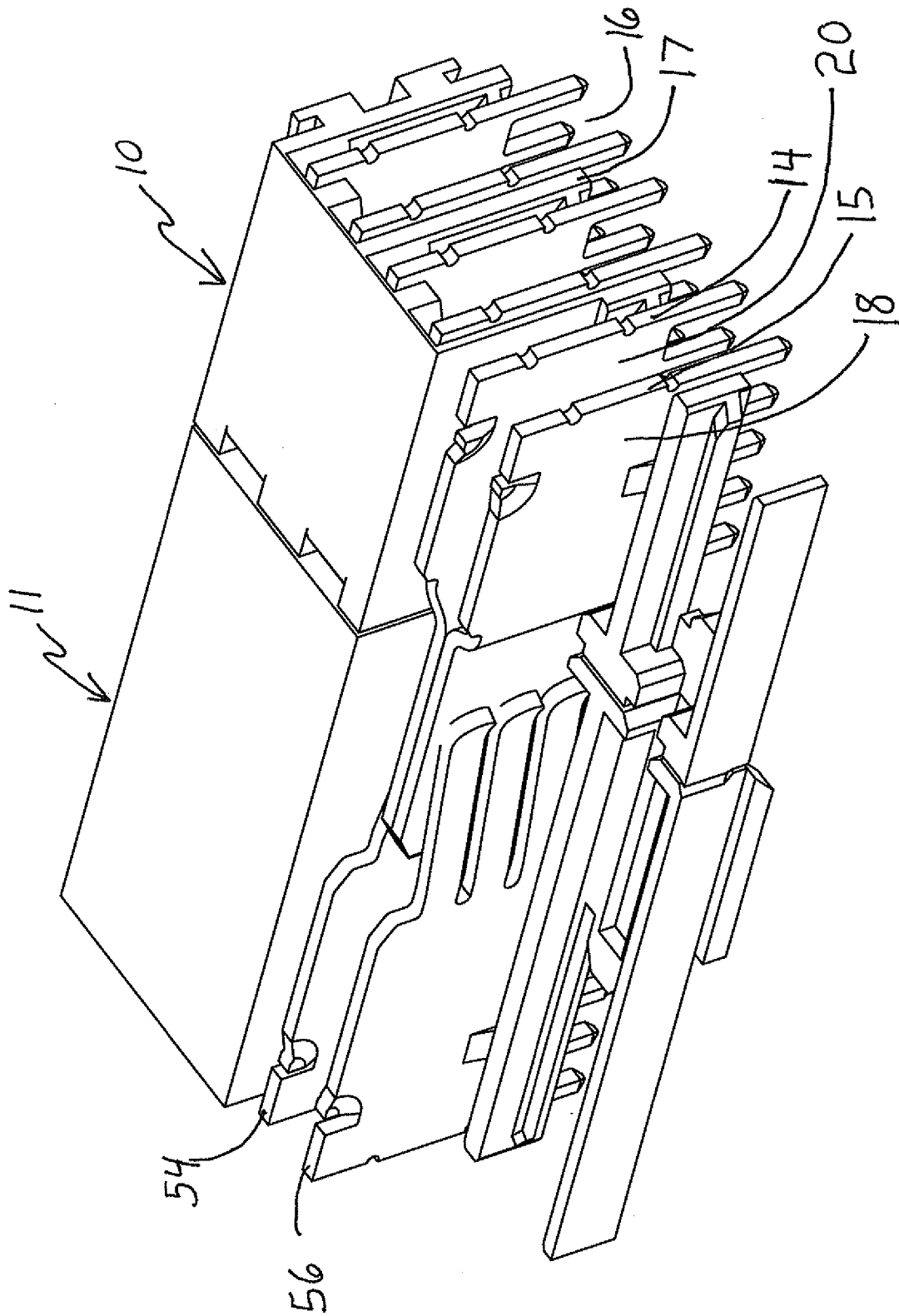

FIG. 1

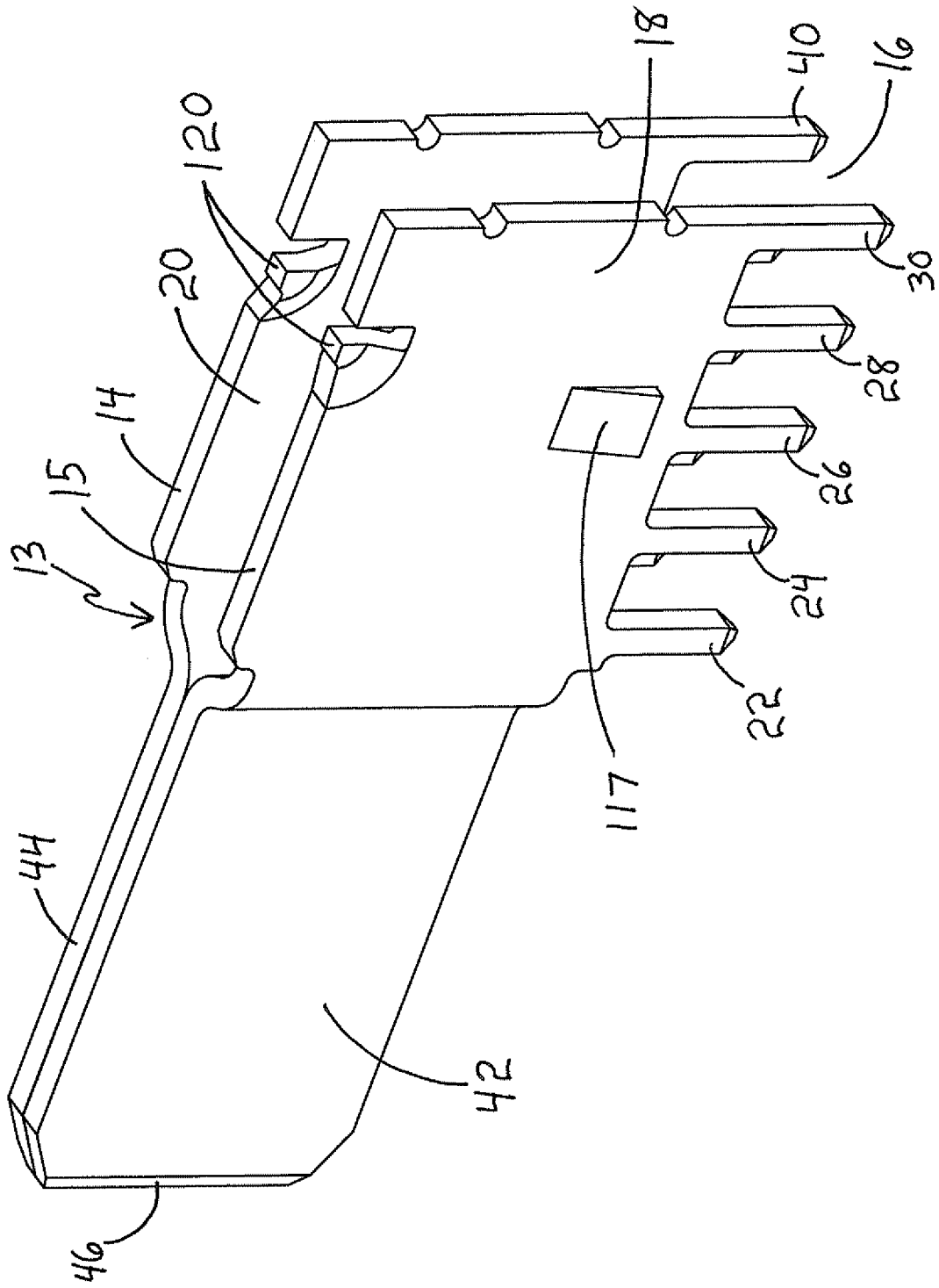

FIG. 1A

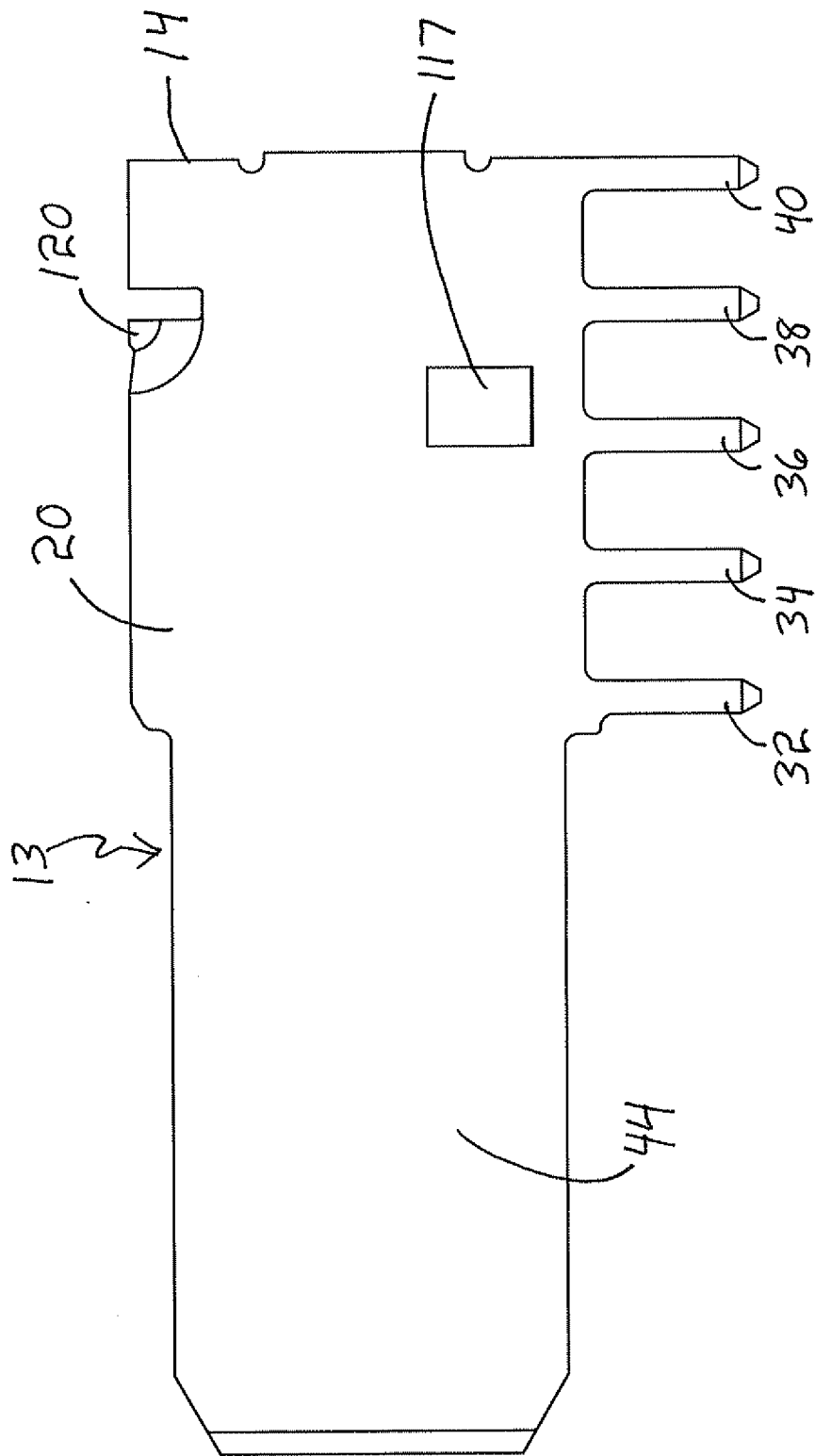

FIG. 1B

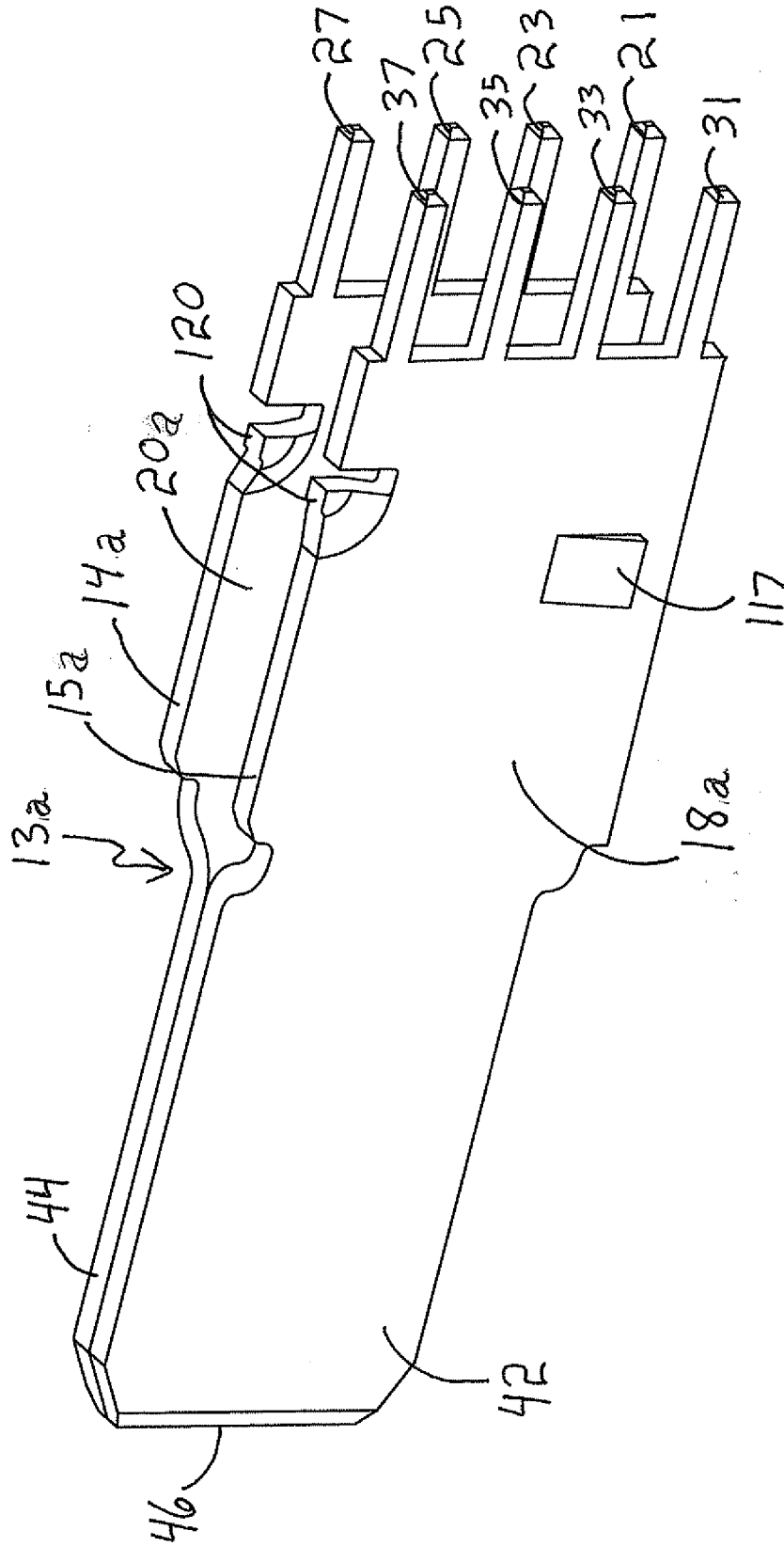

FIG. 2

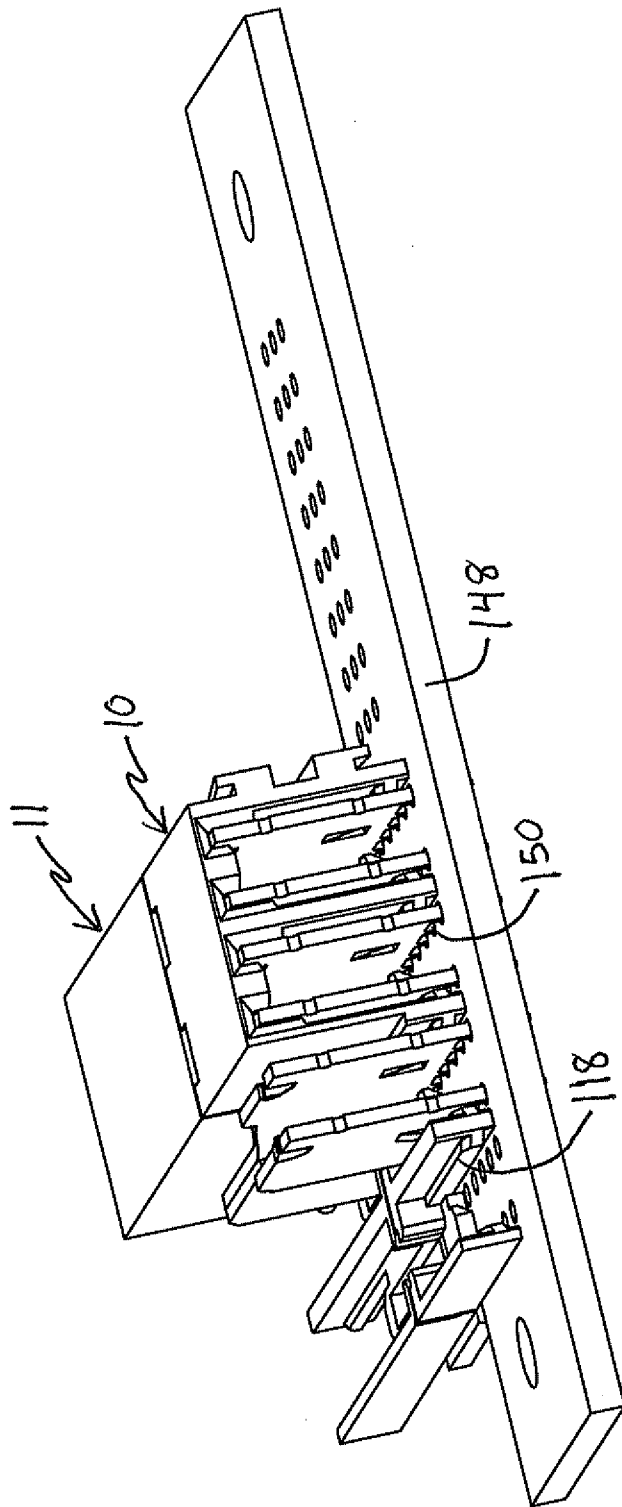

FIG. 3

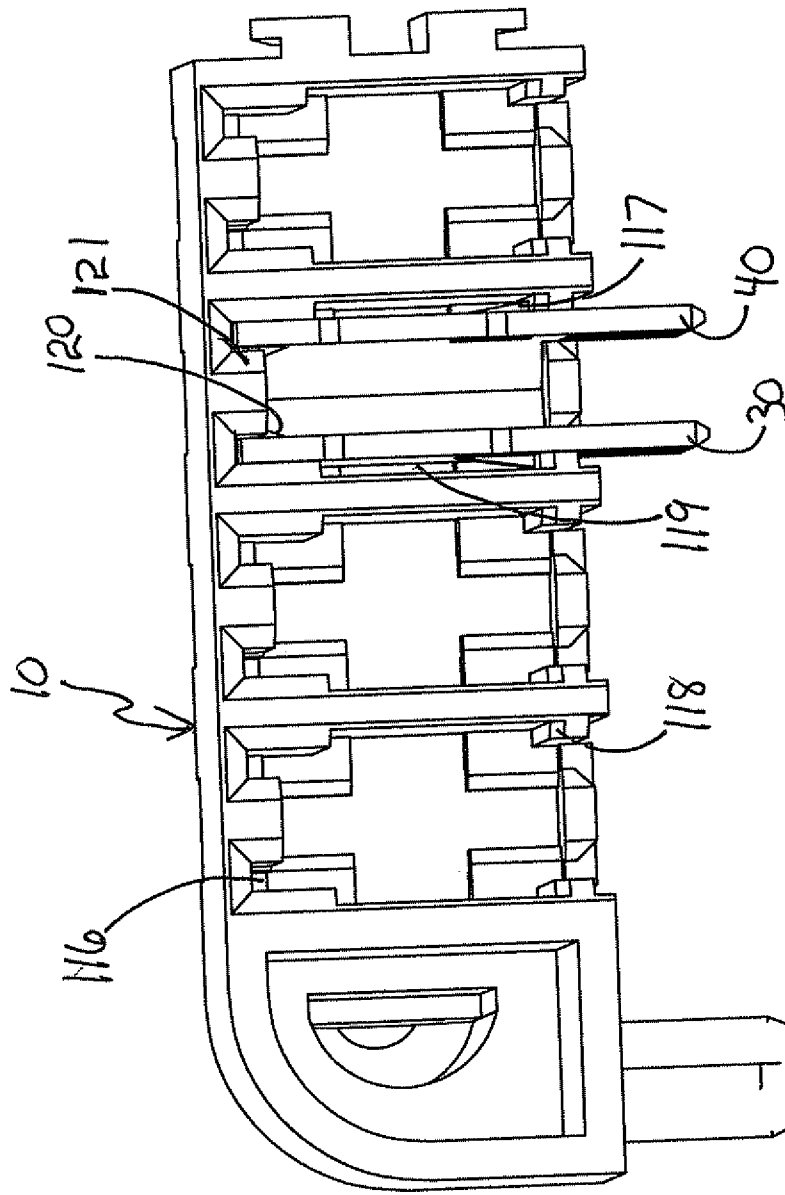

FIG. 4

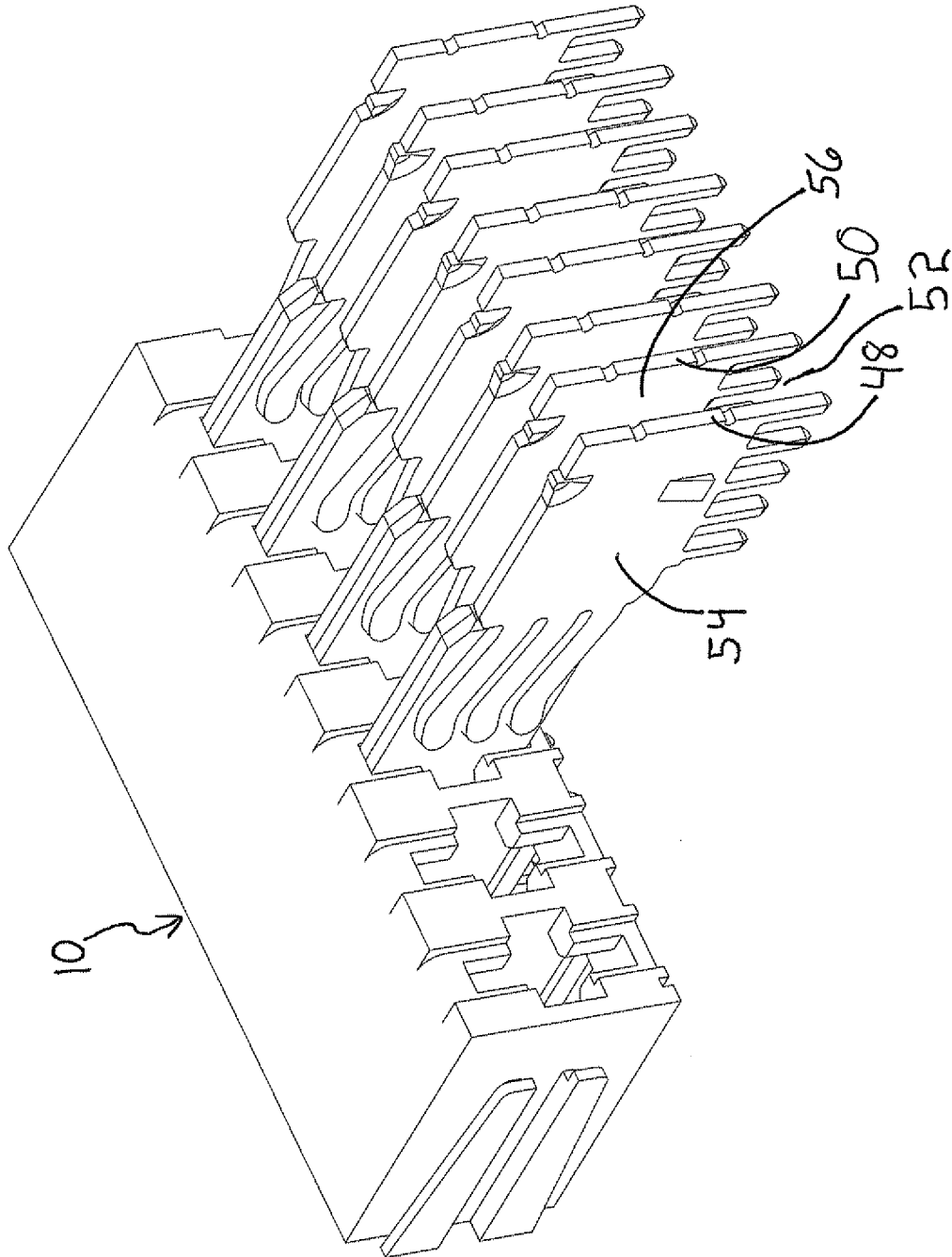

FIG. 5

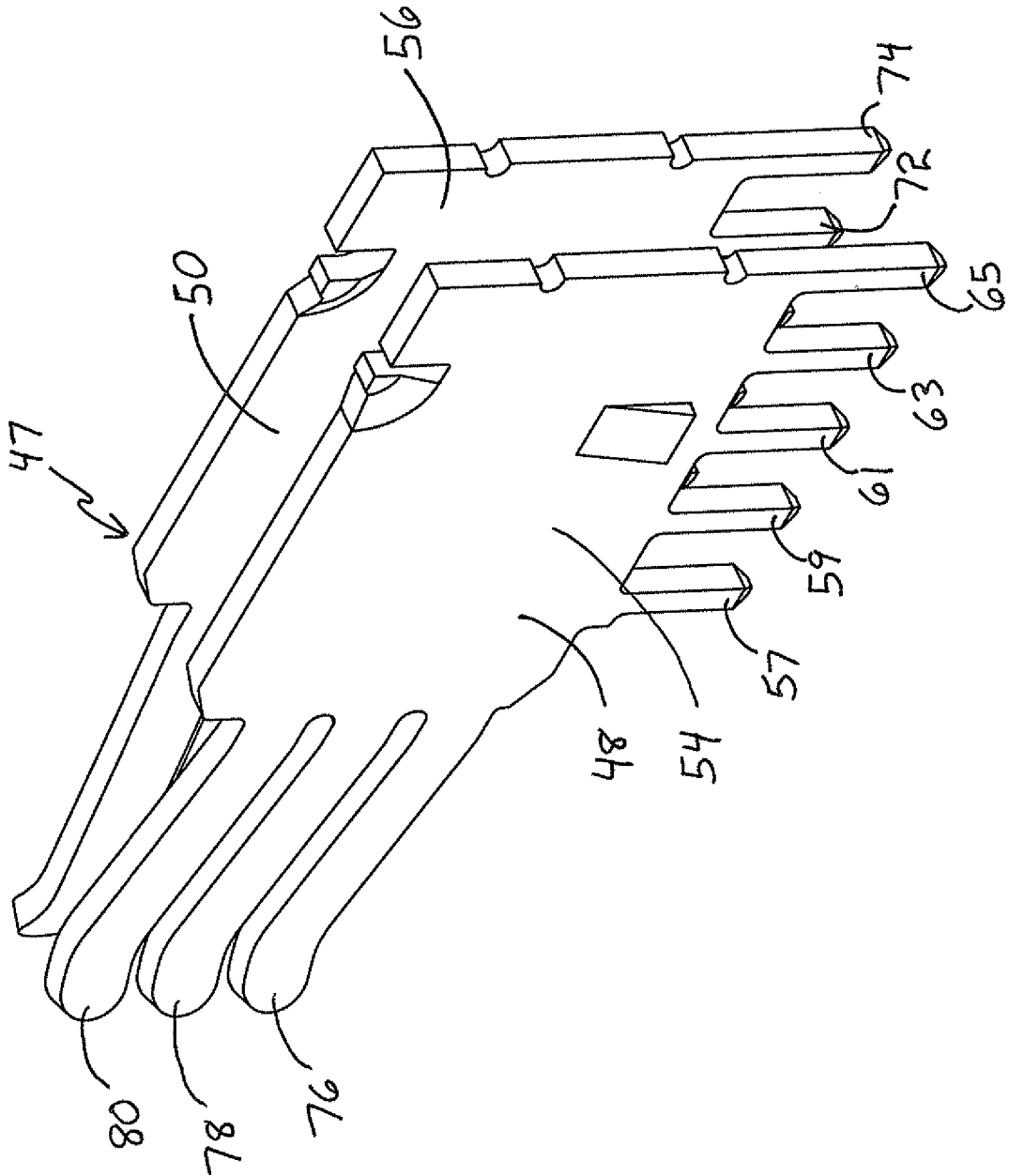

FIG. 5A

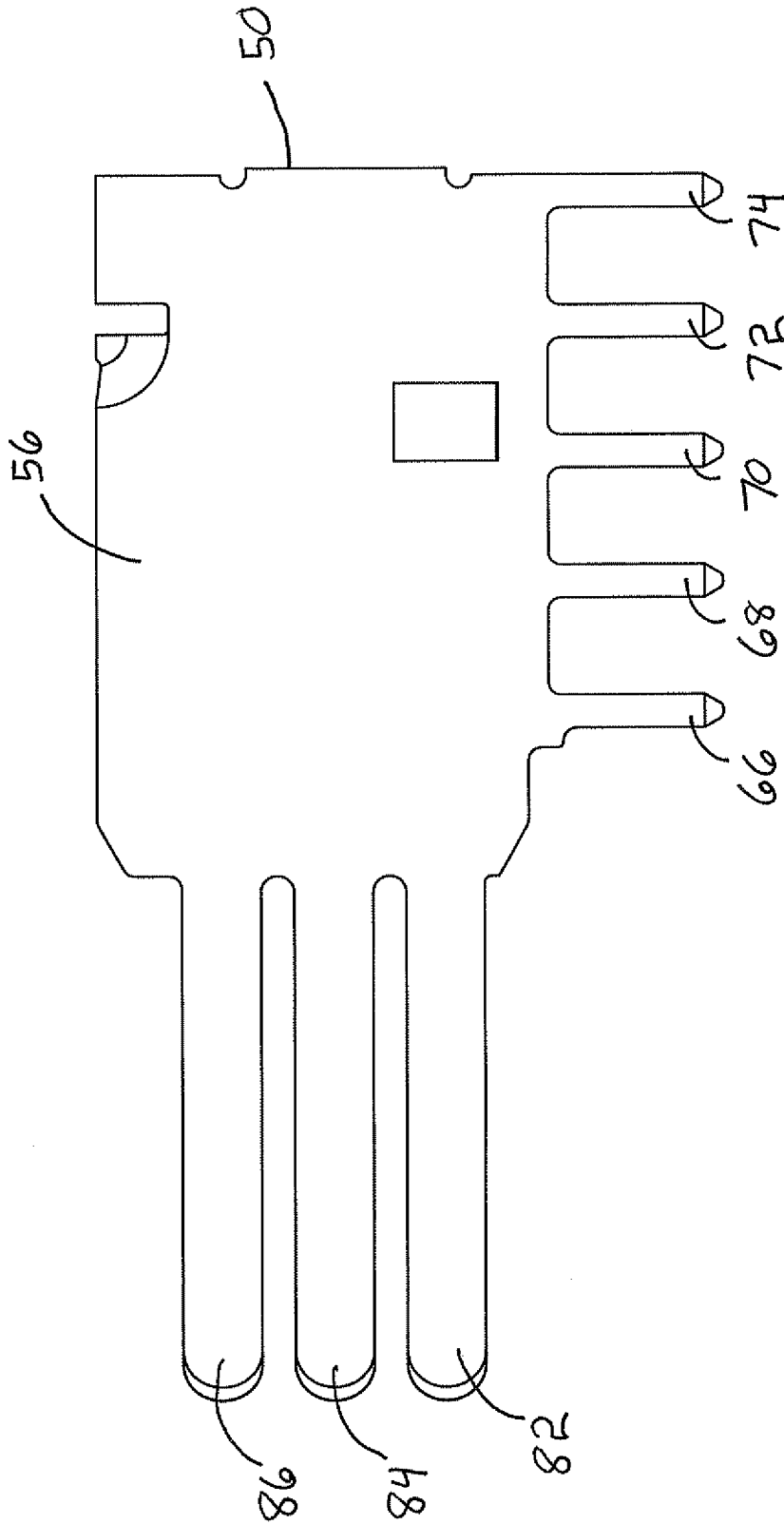

FIG. 5B

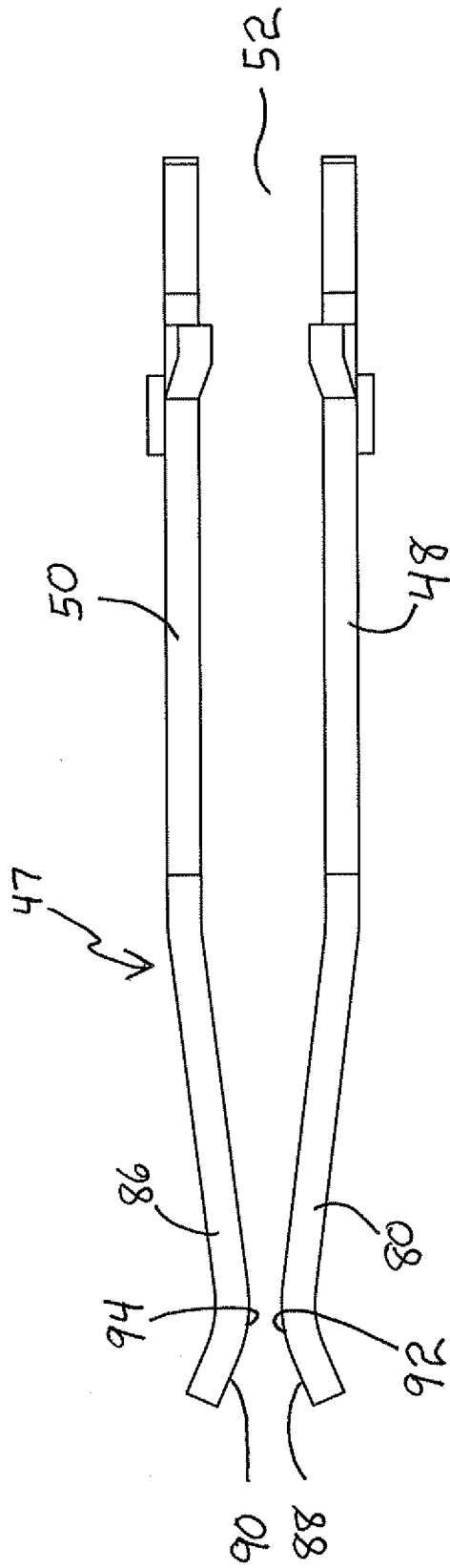

FIG. 5C

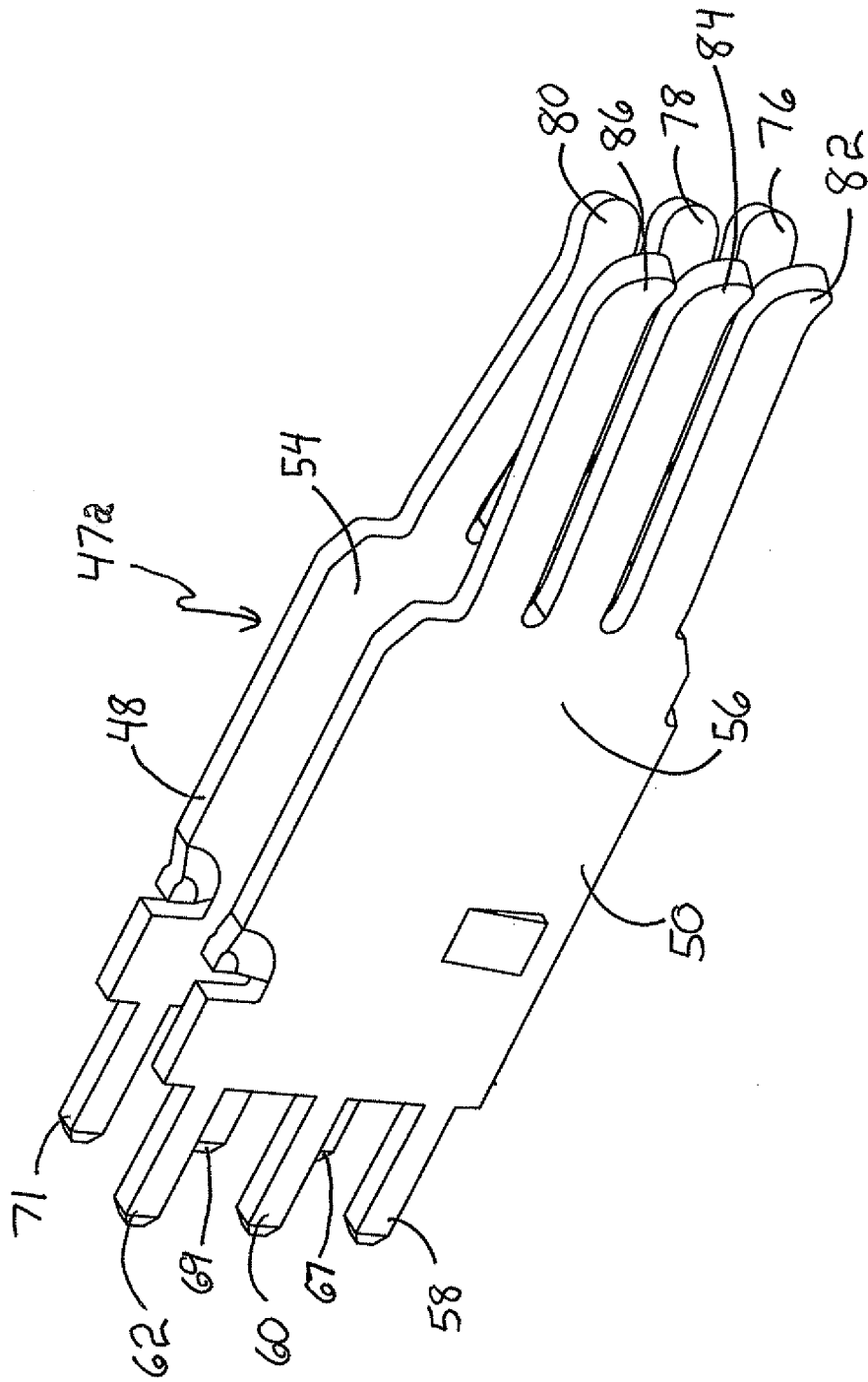

FIG. 6

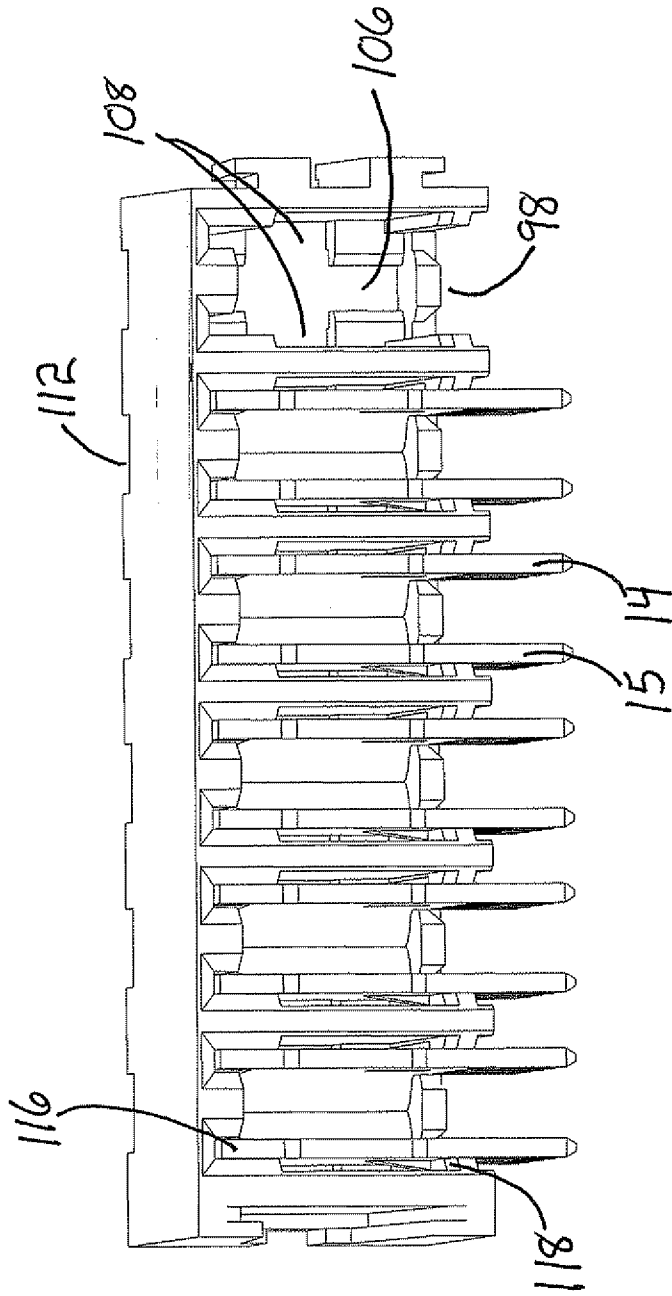

FIG. 7A

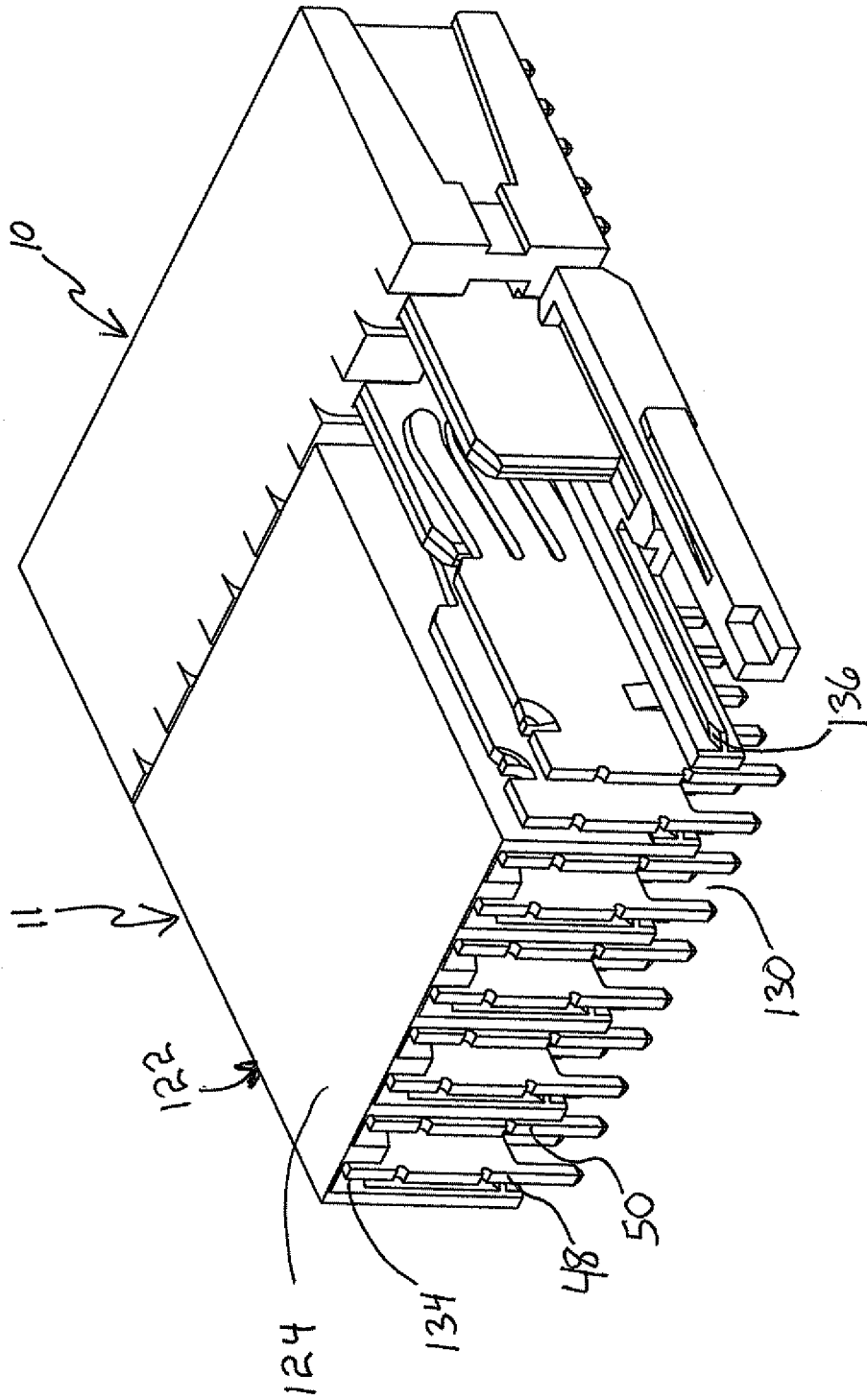

FIG. 8

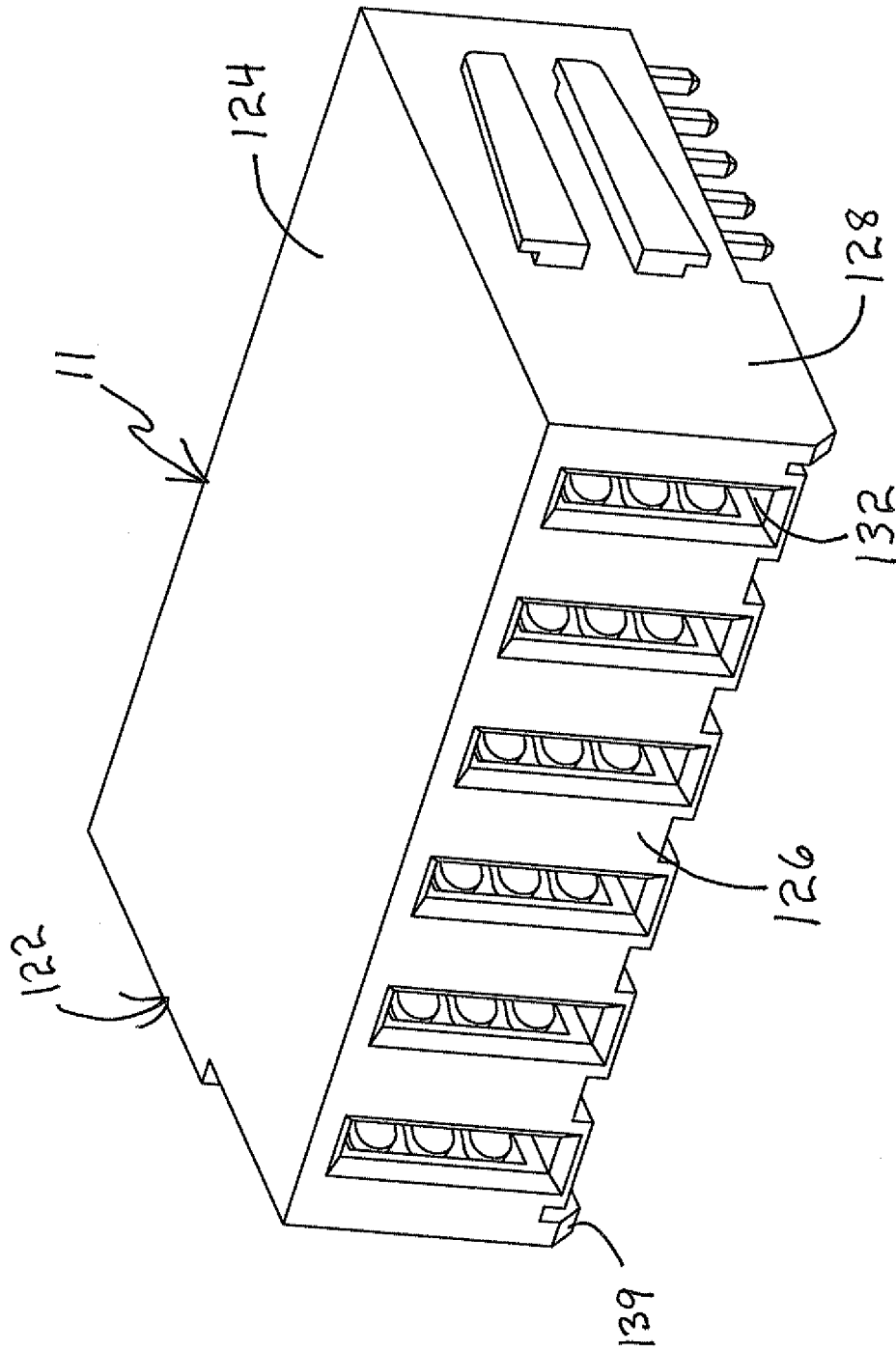

FIG. 8A

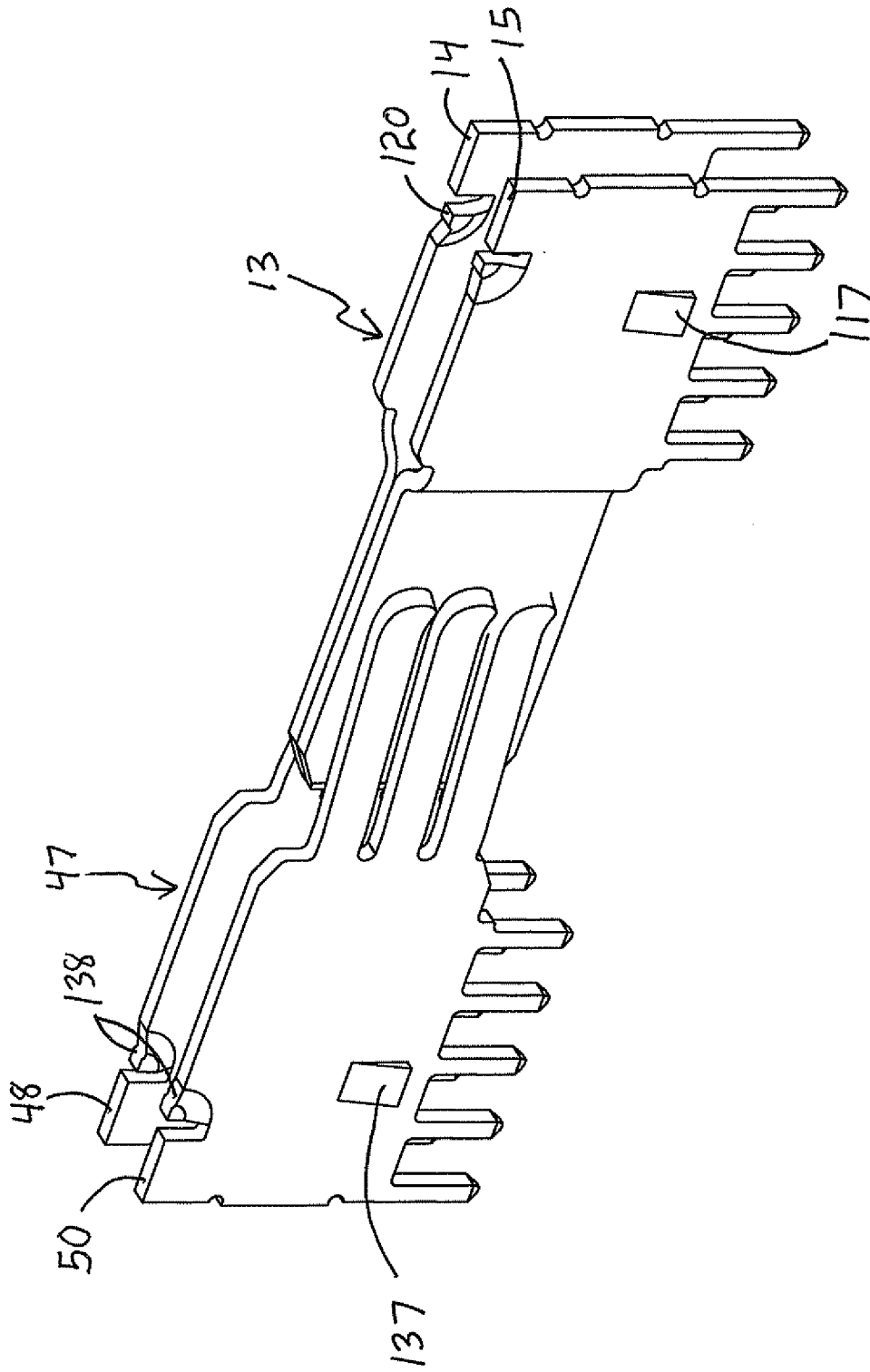

FIG. 8B

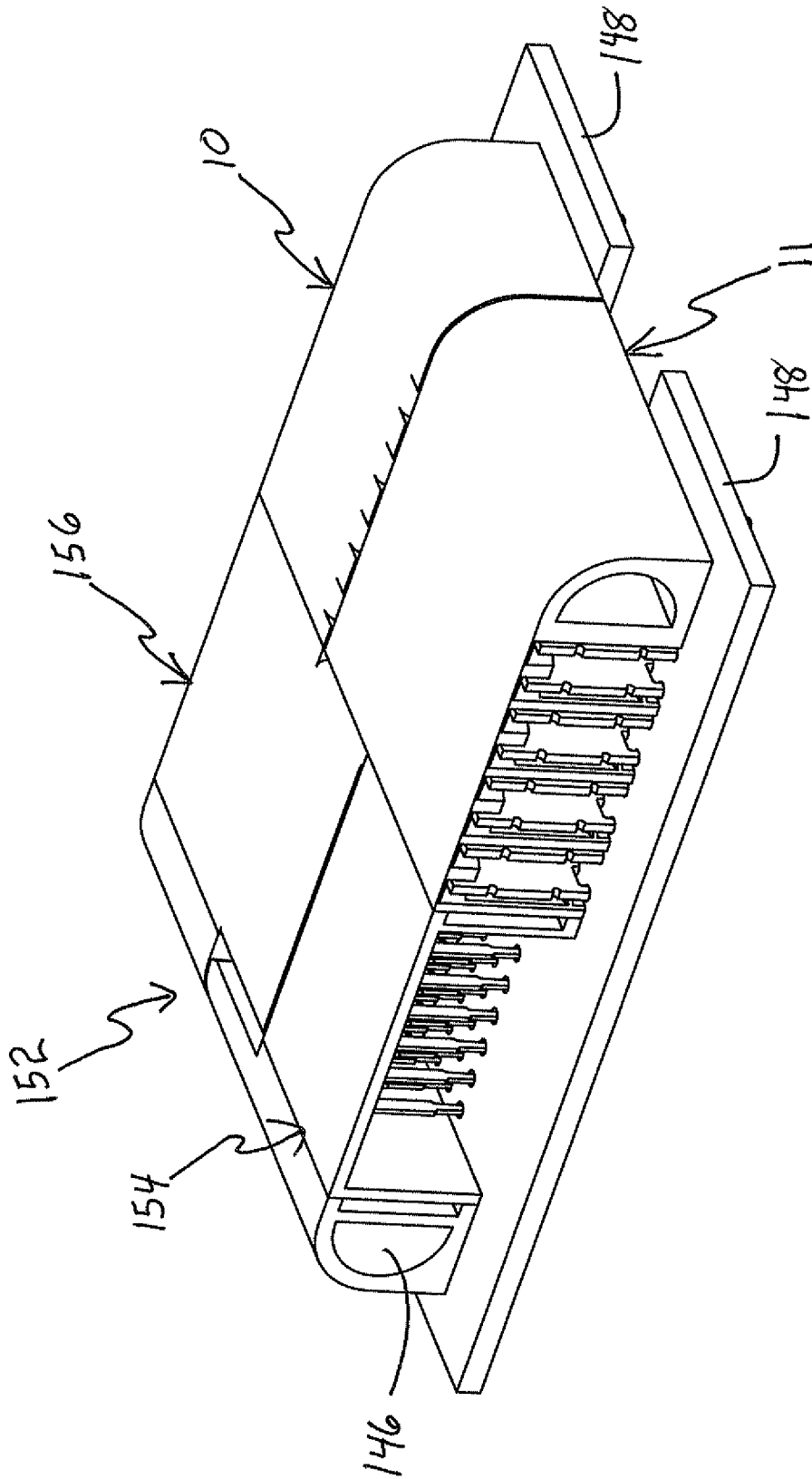

FIG. 9

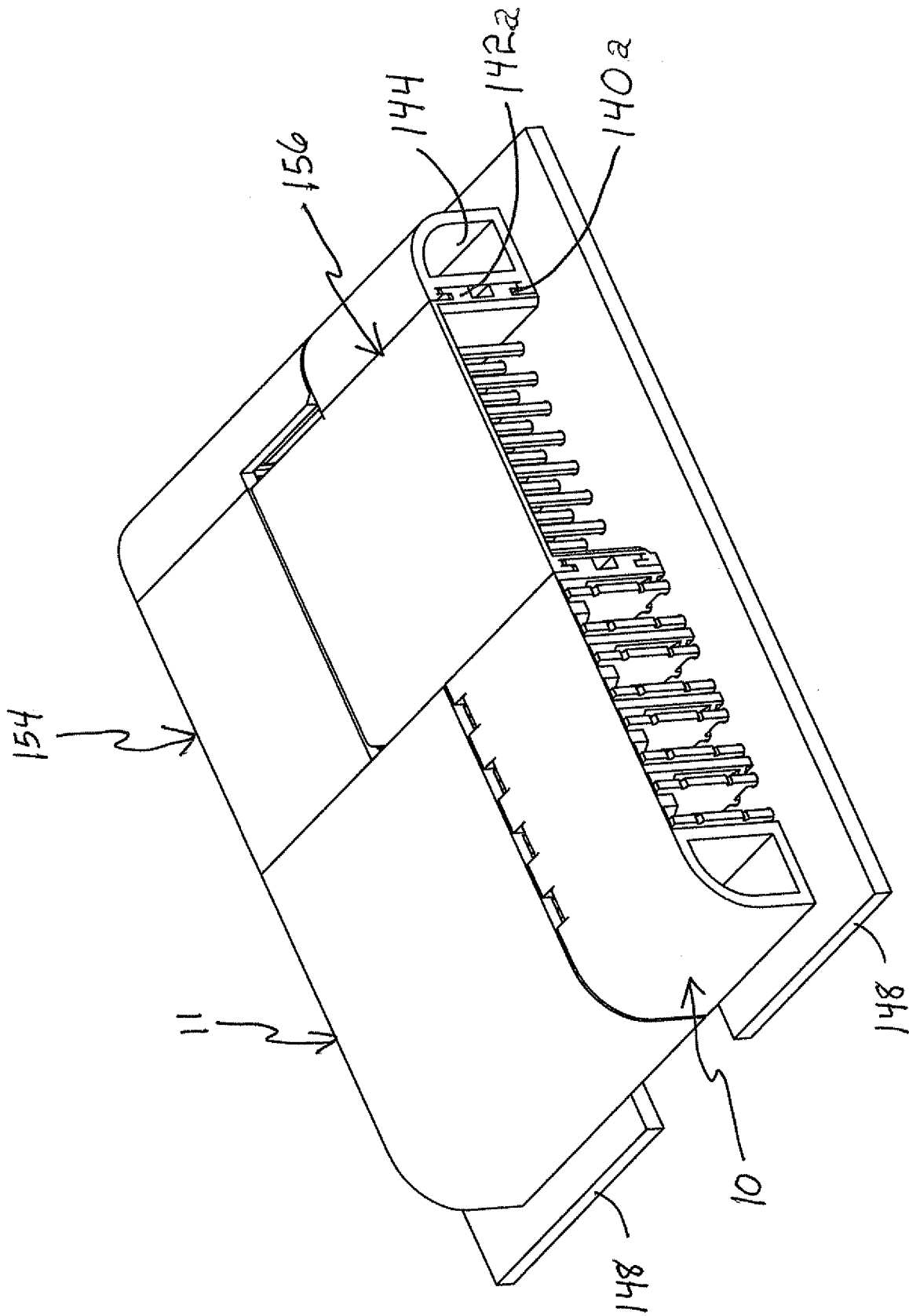

FIG. 10

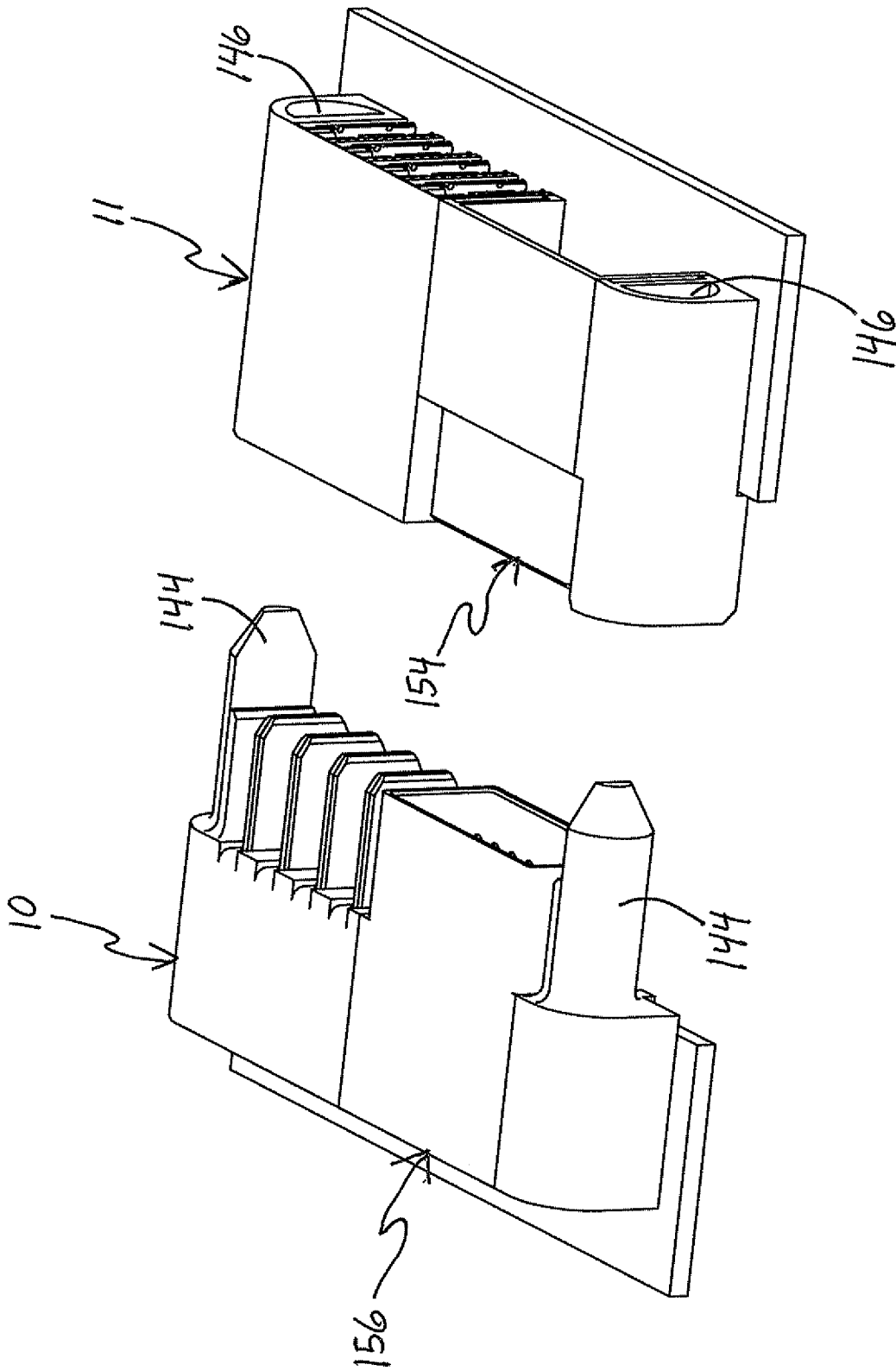

FIG. 11

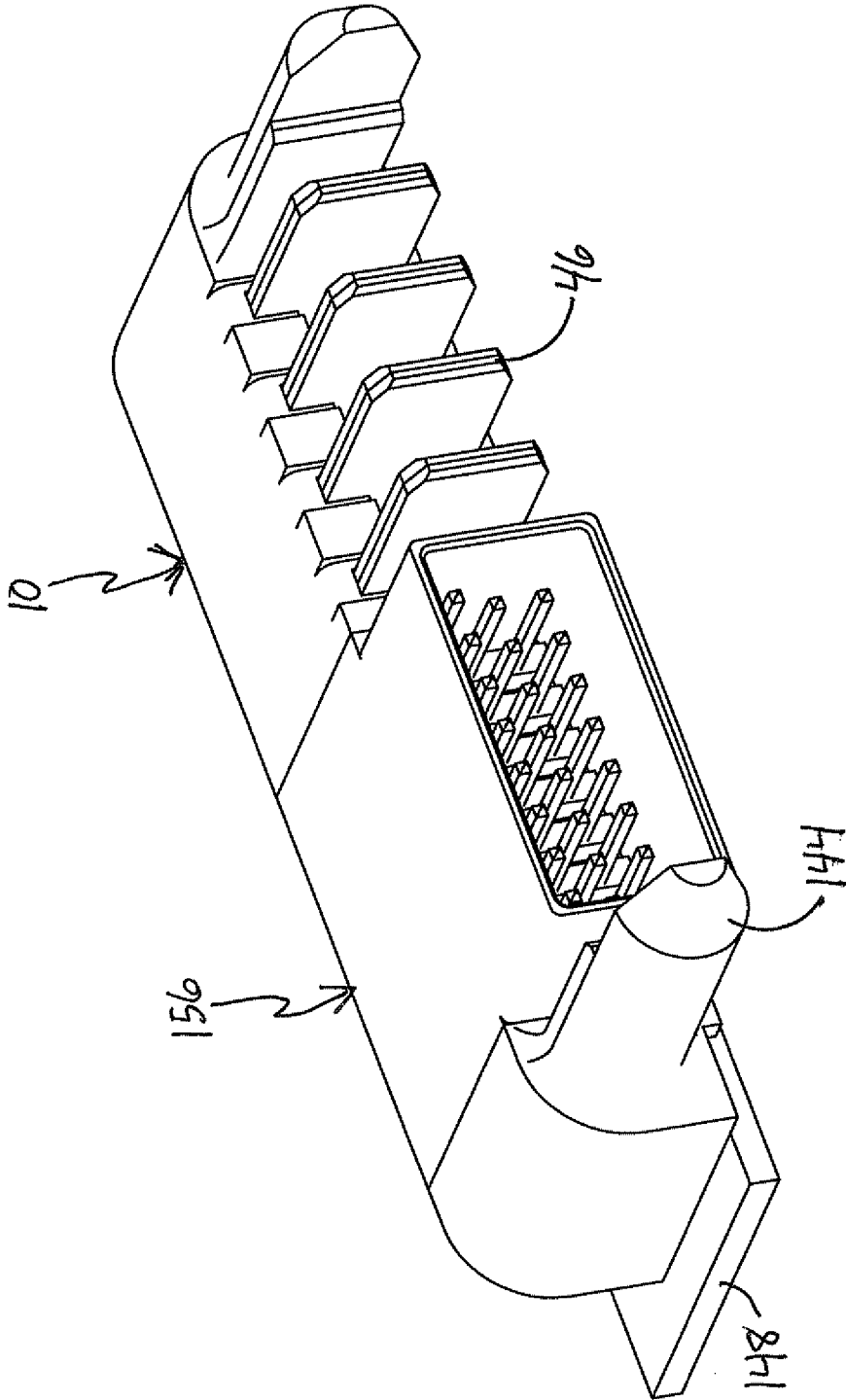

FIG. 12

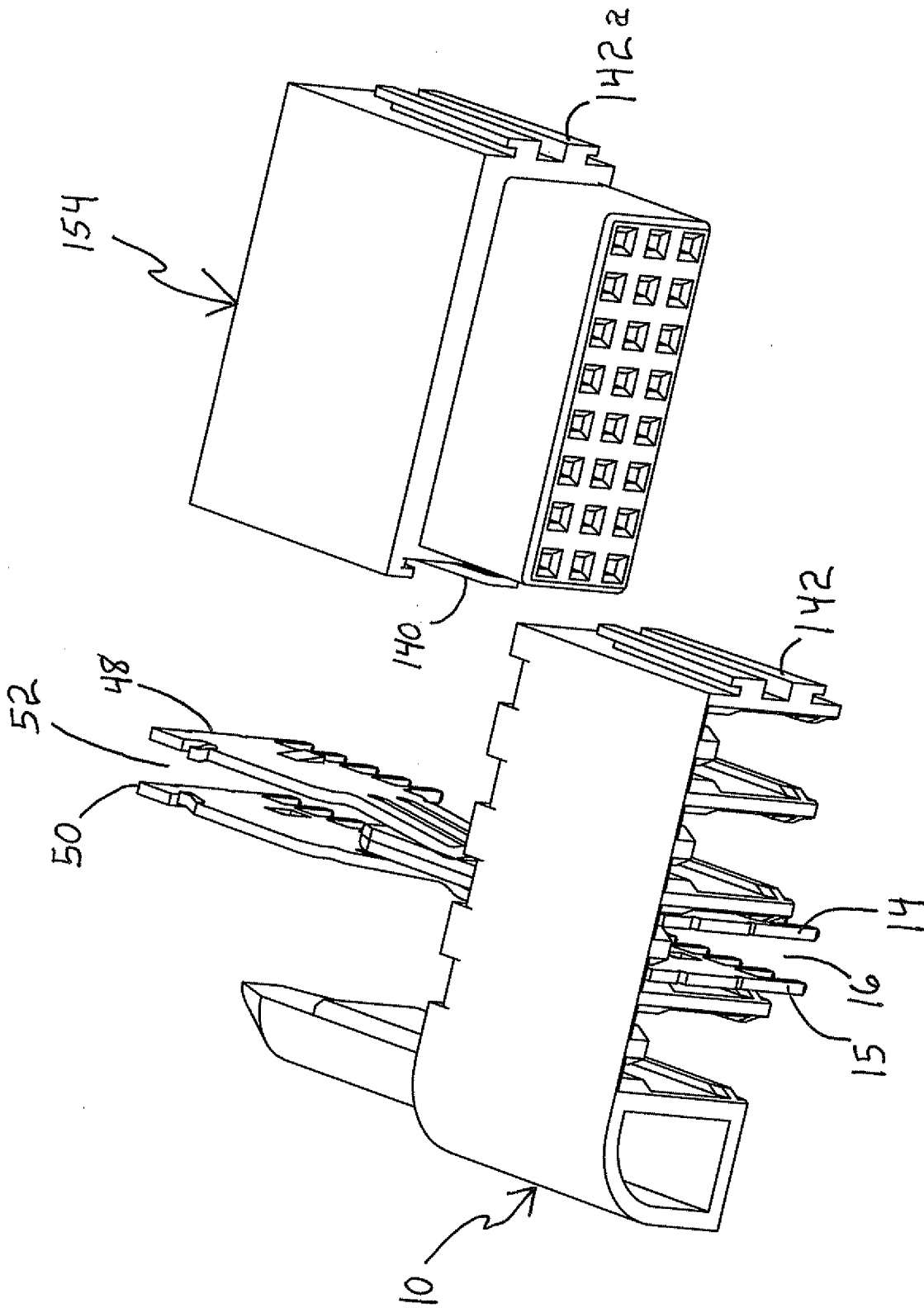

FIG. 13

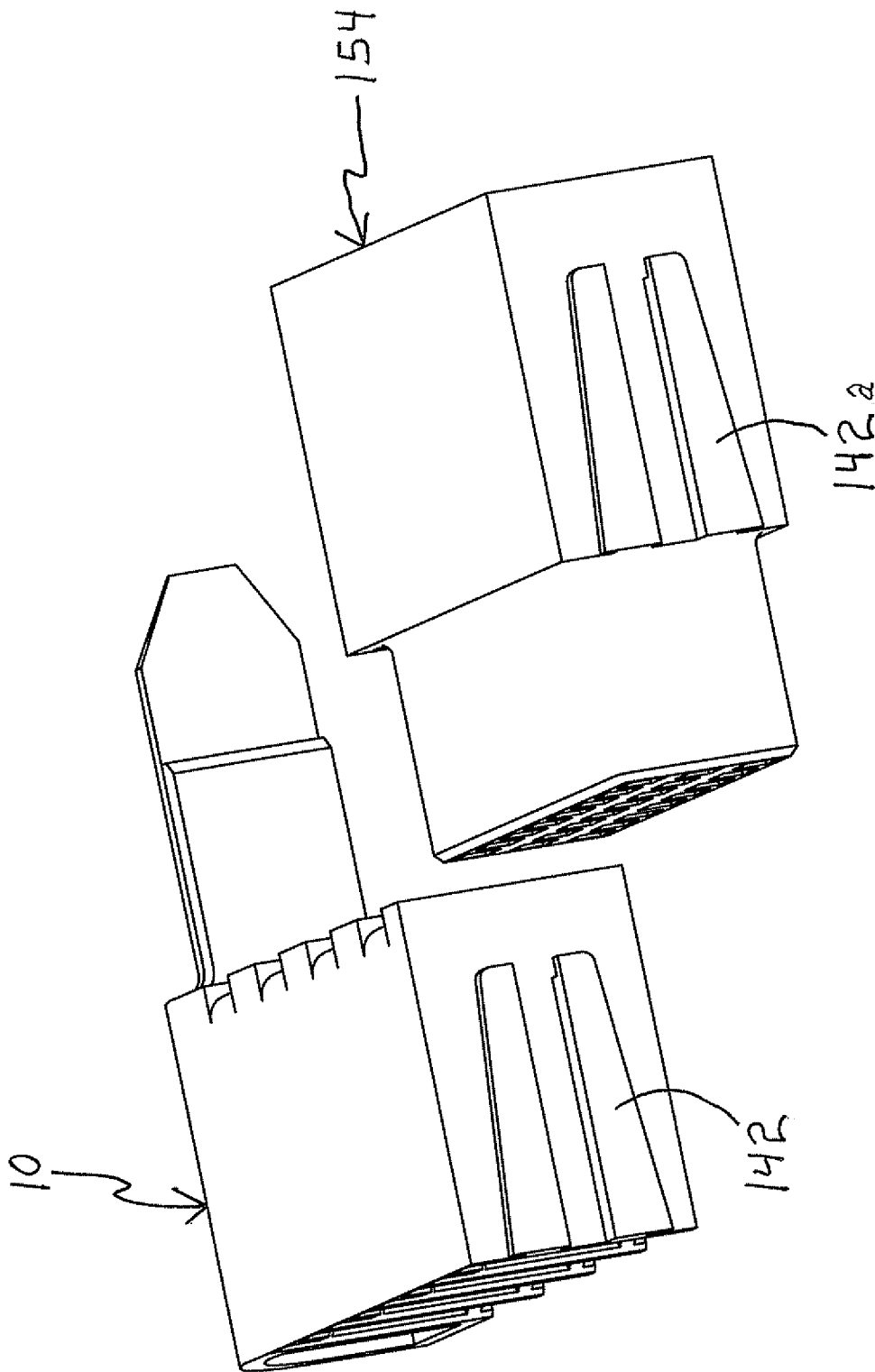

FIG. 14

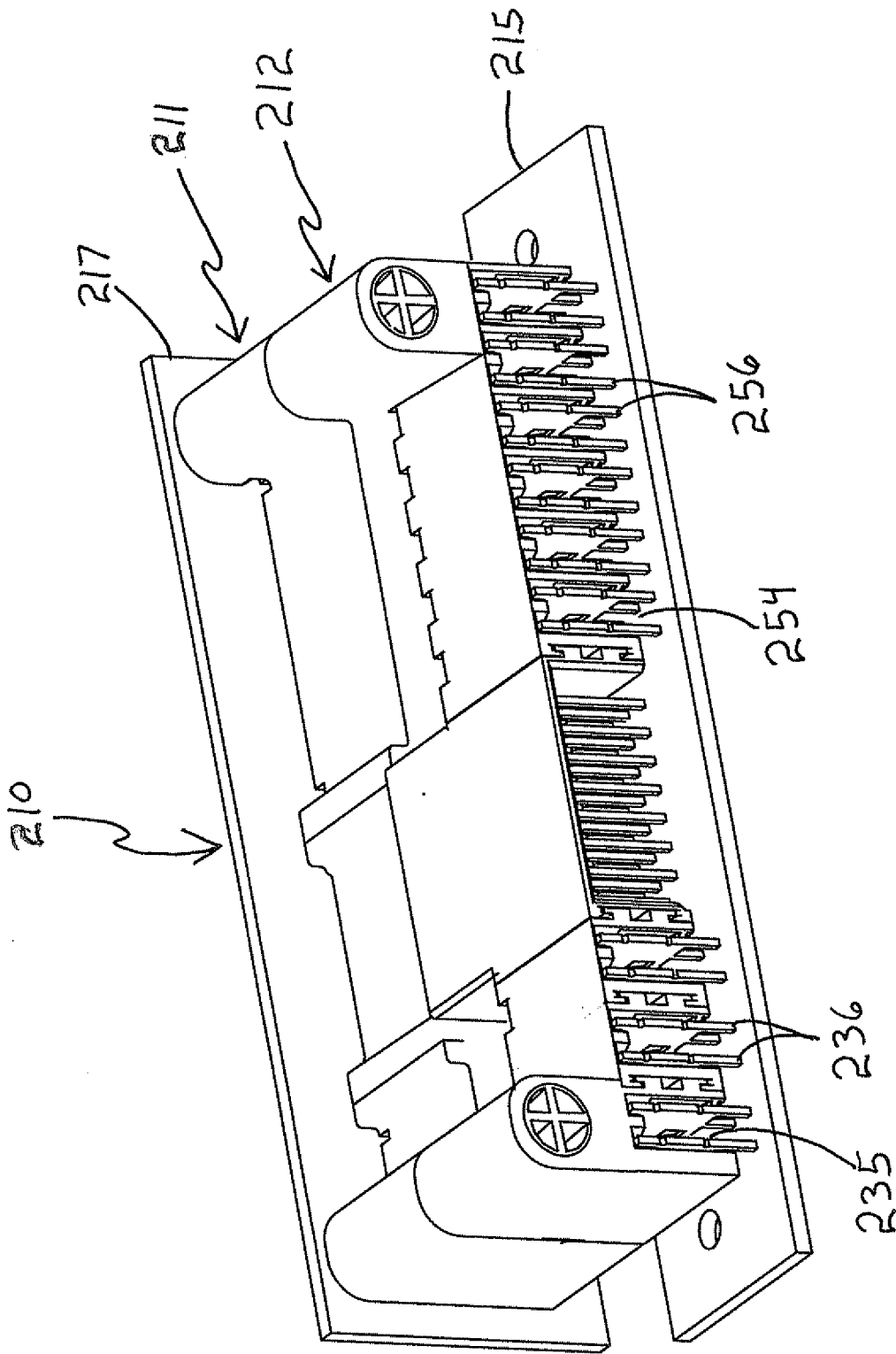

FIG. 15

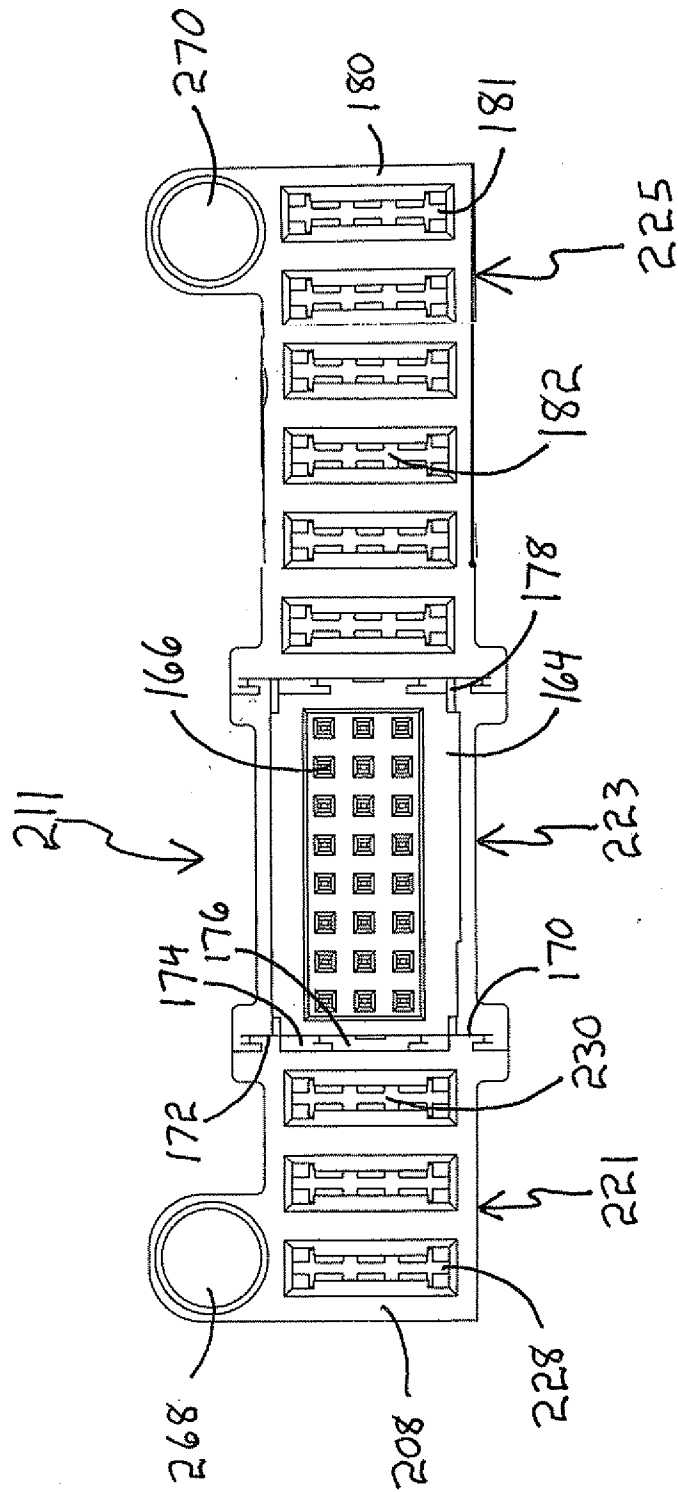

FIG. 16

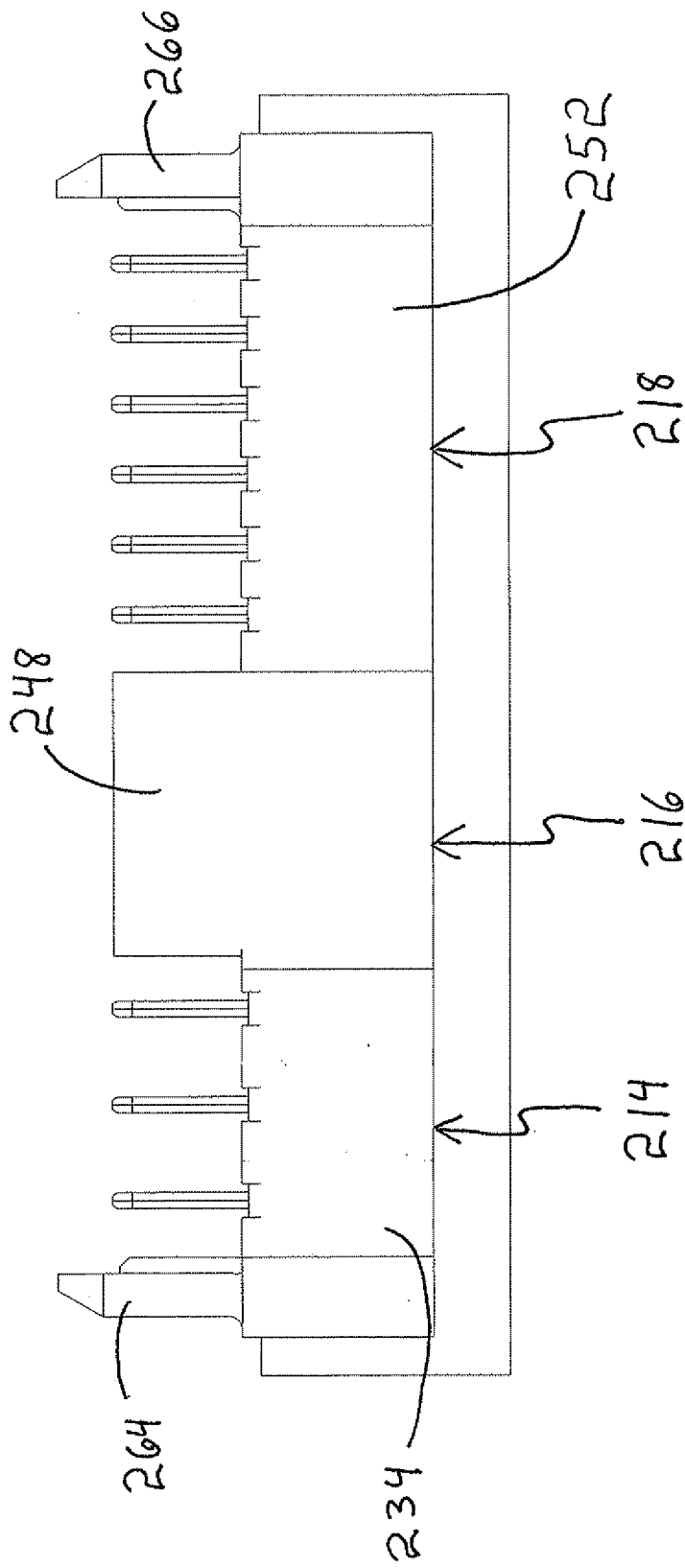

FIG. 17

INTERNATIONAL SEARCH REPORT

International application No

PCT/US2008/085358

A. CLASSIFICATION OF SUBJECT MATTER
 INV. H01R12/14 H01R12/30

According to International Patent Classification (IPC) or to both national classification and IPC

B. FIELDS SEARCHED
 Minimum documentation searched (classification system followed by classification symbols)
 H01R

Documentation searched other than minimum documentation to the extent that such documents are included in the fields searched

Electronic data base consulted during the international search (name of data base and, where practical, search terms used)
 EPO-Internal

Category*	Citation of document, with indication, where appropriate, of the relevant passages	Relevant to claim No.
X	US 6 299 492 B1 (PIERINI JOHN M [US] ET AL) 9 October 2001 (2001-10-09)	1-5, 7-11,13, 20-24, 26-36, 38-40
Y	column 6, line 13 - column 8, line 6; figures 4-10	6,12, 14-19, 25,37
Y	WO 96/13879 A (TVM INC [US]; EATON LARRY D [US]) 9 May 1996 (1996-05-09) page 2, line 17 - page 3, line 8 page 13, line 15 - line 20 page 17, line 11 - line 27 figures 2-9	14-19
	----- -/--	

Further documents are listed in the continuation of Box C.

See patent family annex.

* Special categories of cited documents :

- *A* document defining the general state of the art which is not considered to be of particular relevance
- *E* earlier document but published on or after the international filing date
- *L* document which may throw doubts on priority claim(s) or which is cited to establish the publication date of another citation or other special reason (as specified)
- *O* document referring to an oral disclosure, use, exhibition or other means
- *P* document published prior to the international filing date but later than the priority date claimed

- *T* later document published after the international filing date or priority date and not in conflict with the application but cited to understand the principle or theory underlying the invention
- *X* document of particular relevance; the claimed invention cannot be considered novel or cannot be considered to involve an inventive step when the document is taken alone
- *Y* document of particular relevance; the claimed invention cannot be considered to involve an inventive step when the document is combined with one or more other such documents, such combination being obvious to a person skilled in the art.
- *&* document member of the same patent family

Date of the actual completion of the international search 17 February 2009	Date of mailing of the international search report 25/02/2009
Name and mailing address of the ISA/ European Patent Office, P.B. 5818 Patentlaan 2 NL - 2280 HV Rijswijk Tel. (+31-70) 340-2040, Fax: (+31-70) 340-3016	Authorized officer Criqui, Jean-Jacques

INTERNATIONAL SEARCH REPORT

International application No

PCT/US2008/085358

C(Continuation). DOCUMENTS CONSIDERED TO BE RELEVANT		
Category*	Citation of document, with indication, where appropriate, of the relevant passages	Relevant to claim No.
Y	US 5 667 392 A (KOCHER TIMOTHY LEE [US] ET AL) 16 September 1997 (1997-09-16) column 3, line 61 - column 4, line 49; figures 1,4,5 -----	6,12,25, 37
A	US 4 790 763 A (WEBER RONALD M [US] ET AL) 13 December 1988 (1988-12-13) column 2, line 33 - line 63; figure 1 -----	14-19
A	EP 0 951 102 A (BERG ELECTRONICS MFG [NL] FRAMATOME CONNECTORS INT [FR]) 20 October 1999 (1999-10-20) cited in the application paragraph [0007] - paragraph [0008] paragraph [0011] paragraph [0032] - paragraph [0036] figures 22-24 -----	1-40

INTERNATIONAL SEARCH REPORT

Information on patent family members

International application No

PCT/US2008/085358

Patent document cited in search report	Publication date	Patent family member(s)	Publication date
US 6299492	B1	US 2001039154 A1	08-11-2001
WO 9613879	A	AU 3833595 A	23-05-1996
		DE 69519682 D1	25-01-2001
		DE 69519682 T2	02-08-2001
		EP 0788669 A1	13-08-1997
		US 5575690 A	19-11-1996
US 5667392	A	NONE	
US 4790763	A	NONE	
EP 0951102	A	DE 69921384 D1	02-12-2004
		DE 69921384 T2	20-10-2005
		DE 69926818 D1	22-09-2005
		DE 69926818 T2	08-06-2006
		DE 69927194 D1	13-10-2005
		DE 69927194 T2	29-06-2006
		DE 69937378 T2	17-07-2008
		ES 2245762 T3	16-01-2006
		JP 11329532 A	30-11-1999
		TW 413970 B	01-12-2000
		US 2008182439 A1	31-07-2008
		US 2008214027 A1	04-09-2008
		US 6319075 B1	20-11-2001
		US 2002031925 A1	14-03-2002
		US 2002034889 A1	21-03-2002