

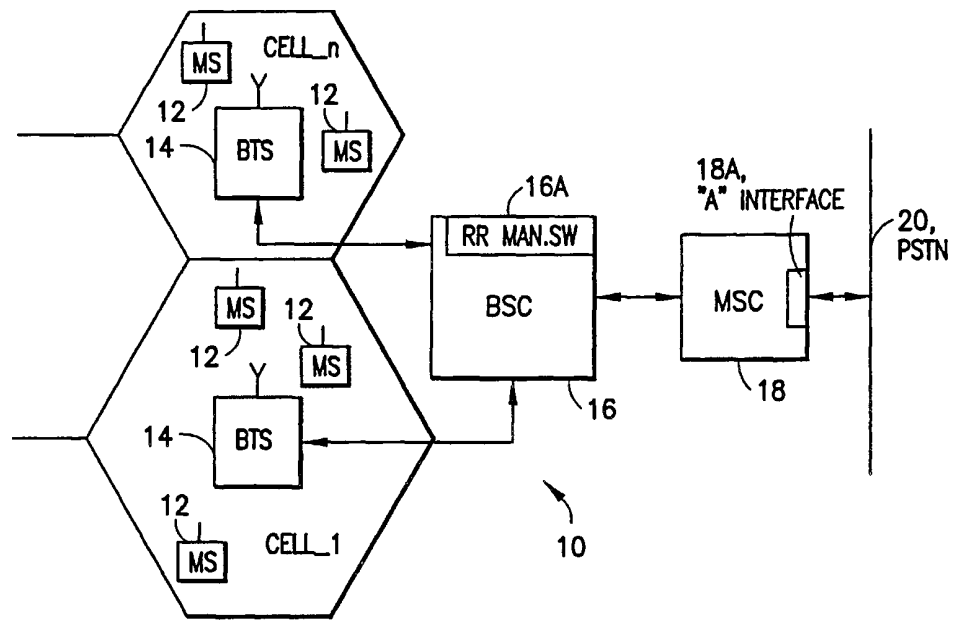

INTERNATIONAL APPLICATION PUBLISHED UNDER THE PATENT COOPERATION TREATY (PCT)

<p>(51) International Patent Classification ⁷ : H04Q 7/20</p>	<p>A1</p>	<p>(11) International Publication Number: WO 00/67498 (43) International Publication Date: 9 November 2000 (09.11.00)</p>
<p>(21) International Application Number: PCT/US00/11953 (22) International Filing Date: 2 May 2000 (02.05.00) (30) Priority Data: 60/132,196 3 May 1999 (03.05.99) US 09/551,012 18 April 2000 (18.04.00) US (71) Applicant (for all designated States except BB): NOKIA MOBILE PHONES LIMITED [FI/FI]; Keilalahdentie 4, FIN-02150 Espoo (FI). (71) Applicant (for BB only): NOKIA INC. [US/US]; 6000 Connection Drive, Irving, TX 75039 (US). (72) Inventors: HAKASTE, Markus; Kuikkarinne 7 B 23, FIN-00200 Helsinki (FI). HAMITI, Shkumbin; Leenankuja 2 K 115, FIN-02230 Espoo (FI). JOKINEN, Harri; Vähähiidentie 450, FIN-25370 Hiisi (FI). NIKULA, Eero; Eestinlaaski 2D 14, FIN-02280 Espoo (FI). (74) Agent: SMITH, Harry, F.; Ohlandt, Greeley, Ruggiero & Perle, L.L.P., 9th floor, One Landmark Square, Stamford, CT 06901-2682 (US).</p>		<p>(81) Designated States: AE, AL, AM, AT, AU, AZ, BA, BB, BG, BR, BY, CA, CH, CN, CR, CU, CZ, DE, DK, DM, EE, ES, FI, GB, GD, GE, GH, GM, HR, HU, ID, IL, IN, IS, JP, KE, KG, KP, KR, KZ, LC, LK, LR, LS, LT, LU, LV, MA, MD, MG, MK, MN, MW, MX, NO, NZ, PL, PT, RO, RU, SD, SE, SG, SI, SK, SL, TJ, TM, TR, TT, TZ, UA, UG, UZ, VN, YU, ZA, ZW, ARIPO patent (GH, GM, KE, LS, MW, SD, SL, SZ, TZ, UG, ZW), Eurasian patent (AM, AZ, BY, KG, KZ, MD, RU, TJ, TM), European patent (AT, BE, CH, CY, DE, DK, ES, FI, FR, GB, GR, IE, IT, LU, MC, NL, PT, SE), OAPI patent (BF, BJ, CF, CG, CI, CM, GA, GN, GW, ML, MR, NE, SN, TD, TG). Published <i>With international search report.</i></p>

(54) Title: ASYMMETRIC DATA TRANSMISSION FOR USE IN A MULTI-MODULATION ENVIRONMENT



(57) Abstract
A data transmission method and system (10) for circuit switched and other services that can be employed in TDMA-based systems, and that supports the use of one or several types of modulation in addition to a "normal" modulation on a radio interface (fig. 4). An additional modulation/channel coding may be used in the downlink transmission (14 and 12), while the normal modulation/channel coding may be used in the uplink transmissions (12 and 14), under a variety of different conditions (Fig. 1).

FOR THE PURPOSES OF INFORMATION ONLY

Codes used to identify States party to the PCT on the front pages of pamphlets publishing international applications under the PCT.

AL	Albania	ES	Spain	LS	Lesotho	SI	Slovenia
AM	Armenia	FI	Finland	LT	Lithuania	SK	Slovakia
AT	Austria	FR	France	LU	Luxembourg	SN	Senegal
AU	Australia	GA	Gabon	LV	Latvia	SZ	Swaziland
AZ	Azerbaijan	GB	United Kingdom	MC	Monaco	TD	Chad
BA	Bosnia and Herzegovina	GE	Georgia	MD	Republic of Moldova	TG	Togo
BB	Barbados	GH	Ghana	MG	Madagascar	TJ	Tajikistan
BE	Belgium	GN	Guinea	MK	The former Yugoslav Republic of Macedonia	TM	Turkmenistan
BF	Burkina Faso	GR	Greece	ML	Mali	TR	Turkey
BG	Bulgaria	HU	Hungary	MN	Mongolia	TT	Trinidad and Tobago
BJ	Benin	IE	Ireland	MR	Mauritania	UA	Ukraine
BR	Brazil	IL	Israel	MW	Malawi	UG	Uganda
BY	Belarus	IS	Iceland	MX	Mexico	US	United States of America
CA	Canada	IT	Italy	NE	Niger	UZ	Uzbekistan
CF	Central African Republic	JP	Japan	NL	Netherlands	VN	Viet Nam
CG	Congo	KE	Kenya	NO	Norway	YU	Yugoslavia
CH	Switzerland	KG	Kyrgyzstan	NZ	New Zealand	ZW	Zimbabwe
CI	Côte d'Ivoire	KP	Democratic People's Republic of Korea	PL	Poland		
CM	Cameroon	KR	Republic of Korea	PT	Portugal		
CN	China	KZ	Kazakstan	RO	Romania		
CU	Cuba	LC	Saint Lucia	RU	Russian Federation		
CZ	Czech Republic	LI	Liechtenstein	SD	Sudan		
DE	Germany	LK	Sri Lanka	SE	Sweden		
DK	Denmark	LR	Liberia	SG	Singapore		
EE	Estonia						

ASYMMETRIC DATA TRANSMISSION FOR USE IN A MULTI-MODULATION ENVIRONMENT

5 CLAIM OF PRIORITY FROM A COENDING PROVISIONAL PATENT APPLICATION:

Priority is herewith claimed under 35 U.S.C. §119(e) from copending Provisional Patent Application 60/132,196, filed 05/03/99, entitled
10 "Asymmetric Data Transmission in Multi-Modulation Environment", by Markus Hakaste et al. The disclosure of this Provisional Patent Application is incorporated by reference herein in its entirety.

FIELD OF THE INVENTION:

15 This invention relates generally to radiotelephones and, in particular, to radiotelephones or mobile stations capable of operation with a digital wireless telecommunications network.

BACKGROUND OF THE INVENTION:

20 One modern wireless telecommunications system is known as the Global System for Mobile Communication (GSM) Evolution (EDGE), which includes Enhanced Circuit Switched Data (ECSD) and Enhanced Global Packet Radio Service (EGPRS). The teachings of this invention are particularly relevant to the ECSD aspect, as well as to other types of TDMA
25 systems, such as the IS-136 system in the United States, having circuit switched services.

During the EDGE standardization process some mobile equipment or mobile station manufacturers expressed a concern that they were not able to
30 immediately support 8-PSK modulation in their transmitters. The 8-PSK modulation was selected for GSM, in addition to the Gaussian Minimum Shift Keying (GMSK) type of modulation that was already in use. Some manufacturers also expressed an interest in providing low cost mobile equipment that would not support 8-PSK transmissions.

35

As may be appreciated, these limitations make it very difficult to support high bit rate circuit switched services with 8-PSK modulation, without changing the manner in which these services are defined in the GSM specification.

5

Currently, the GSM specification defines circuit switched services as "symmetric" services, that is, using the same modulation/channel coding in both the uplink direction (mobile station (MS) to base transceiver station (BTS)) and in the downlink direction (BTS to MS). Furthermore, there were
10 no proposals as to how to support ECSD services for those "simple" mobile stations that were unable to transmit with 8-PSK modulation in the uplink direction.

One problem that results from this situation, in the case of circuit
15 switched GSM or some other "symmetrical" systems, is in enabling the use of different types of modulation on the same radio interface, wherein the "simple" mobile stations cannot make full use of the system capabilities without having a complex transmitter that supports all system modulation schemes. This is due largely to the current symmetrical nature of the radio
20 interface, where the same modulation/channel coding is used for both MS reception (downlink) and MS transmission (uplink).

Another problem that results in the case of the above-mentioned system(s) is that if a downlink biased data transfer is required by the MS, for
25 example the transfer of a large file on the downlink, with a "more complex" MS that supports several of the system modulation schemes, the MS must, according to current GSM specifications, use the downlink modulation/channel coding also for uplink transmission. However, this type of transmission is not optimal from the MS power consumption and/or uplink
30 robustness point of view. That is, and if one assumes a sufficient amount of BTS transmitter power, the ECSD link can be maintained for a longer distance if GMSK modulation is used in the uplink, as opposed 8-PSK modulation. This is particularly true when the MS operates with limited

transmitter power classes. It should be noted in this regard that even if the MS output power is equal for 8-PSK and GMSK, the link budget is inferior for the 8-PSK modulation case.

5 **OBJECTS AND ADVANTAGES OF THE INVENTION:**

It is a first object and advantage of this invention to provide a technique for accommodating mobile stations with varying modulation capabilities in a wireless telecommunications system.

10 It is a second object and advantage of this invention to provide wireless communications system with an ability to selectively provide symmetrical or asymmetrical data services in the downlink or the uplink, and to further enable different types of modulation and bit rates to be used in the downlink and the uplink.

15

SUMMARY OF THE INVENTION

The foregoing and other problems are overcome and the objects of the invention are realized by methods and apparatus in accordance with embodiments of this invention.

20

The teachings of this invention provide a data transmission method and system (e.g., GSM EDGE) for circuit switched and other services that is employed, preferably, in TDMA-based systems, and that supports the use of one or several types of modulation (e.g., 8-PSK modulation), in addition to a "normal" modulation (e.g., GMSK modulation) on the radio interface. An additional modulation/channel coding (e.g., one based on 8-PSK) may be used in the downlink transmission, while the normal modulation/channel coding (e.g., one based on GMSK) may be used in the uplink transmissions, under a variety of different conditions.

25
30

A first condition arises where the radio conditions allow the use of the additional modulation in both directions, but the mobile station transmitter does not support the additional modulation. For example, the mobile station

may be capable of receiving 8-PSK downlink transmissions, but is only capable of GMSK modulated uplink transmissions.

5 A second condition arises where the radio conditions allow the use of the additional modulation in both directions, and the mobile station supports the additional modulation, but the user requests a downlink-biased (or an uplink-biased) data transmission service.

10 A third condition arises where the mobile station supports the use of the additional modulation in both directions, but the uplink (or the downlink) radio conditions do not permit the use of the additional modulation (e.g., because of link budget limitations.)

15 Under all of the foregoing conditions, the same Layer-3 (L3) protocol format is used in both directions for transferring the data frames (e.g., 14.5kbps Radio Link Protocol (RLP)).

20 Under the second condition, the mobile station automatically uses the normal modulation in the uplink according to the user's request, and the base station uses a blind detection of the uplink bursts to identify the type of modulation used for the uplink transmissions.

25 Also under the second condition, the mobile station indicates during call setup signaling that the downlink biased service is requested by the user, and the network establishes the connection accordingly.

30 Under the third condition, if the link budget is not sufficient for 8-PSK modulation (or some other type of additional modulation), the network may command a power control level that is not supported by the mobile station for the additional modulation. In this case the mobile station will, preferably, use a nearest supported output power control level.

The teachings of this invention enable the use of different data rates

for the uplink and the downlink, thus providing improved radio resource utilization, a simpler ECSD mobile station implementation and, assuming a reduced power consumption for the ECSD mobile station, an extended range of the cell for ECSD services. Further in this regard, and as was
5 indicated above, even if the mobile station output power is equal for both the 8-PSK and GMSK modulation cases, the link budget is generally inferior for 8-PSK.

Also, a lower data rate may be desired on the uplink in order to
10 reduce the power consumption of the mobile station, and/or in the downlink direction to avoid unnecessary interference. This is especially true in the case that one direction or the other has less data to transmit, and the high speed data transmission mode is not required (even if supported).

15 **BRIEF DESCRIPTION OF THE DRAWINGS**

The above set forth and other features of the invention are made more apparent in the ensuing Detailed Description of the Invention when read in conjunction with the attached Drawings, wherein:

20 Fig. 1 depicts various possible uplink (UL) and downlink (DL) data rate combinations, expressed in thousands of bits per second (kbps);

Fig. 2 is an example of signalling between the mobile station (MS), base transceiver station (BTS), base station controller (BSC) and mobile
25 switching center (MSC) for an (explicit) asymmetry case;

Fig. 3 is an example of signalling between the MS, BTS, BSC and MSC for an (implicit) asymmetry case; and

30 Fig. 4 is a simplified block diagram of a wireless digital telecommunications system that is suitable for practicing this invention.

DETAILED DESCRIPTION OF THE INVENTION

It should be realized at the outset that, while the invention will be described below in the context of a TDMA-type system (e.g., GSM or enhanced GSM), certain aspects of the teachings of this invention can be extended to other types of systems, such as CDMA systems. Furthermore, the teachings of this invention are not limited for use with only circuit-switched embodiments, but have wider applicability. For example, the teachings of this invention can be extended to packet radio services as well. In general, any system that is capable of using different modulation types may benefit from the use of the teachings found herein, although the gain may be less significant in a system that employs linear modulation as a "basic" modulation type, i.e., that employs a basic modulation type that provides the best range properties.

Fig. 4 is a simplified block diagram of a cellular telecommunications system 10 in accordance with a presently preferred embodiment of this invention. The system 10 is assumed for the purposes of this description to be a GSM system or a GSM-type system. However, the teachings of this invention are not limited for use in only GSM or GSM-type systems.

A plurality of mobile stations (MS) 12 are located within cells (Cell_1, ..., Cell_n) each of which is associated with a base transceiver station (BTS) 14. The various BTS 14 are coupled to a base station controller (BSC) 16, which in turn is coupled to a mobile switching center (MSC) 18. The MSC 18 provides connections through an "A" interface 18A to external telephone and data networks, such as the public switched telephone network (PSTN) 20, as well as to packet data networks, etc. In other embodiments each BTS 14 may have its own BSC 16. The BSC 16 includes a Radio Resource Management software module or function 16A, or some equivalent thereto, which is employed for managing the radio links in the various cells.

While this invention will be described below in the context of GSM

EDGE. this is but one example of where and how the teachings of this invention can be applied.

5 It is first noted that current signaling mechanisms for GSM and High Speed Circuit Switched Data (HSCSD, defined in GSM 03.34) do not provide support for the case where different channel codings are used for the uplink and the downlink. In order to provide a reduced complexity solution it is desirable to employ the current signaling mechanisms to the greatest extent possible. The signaling for the support of asymmetric cases in ECSD can be
10 accomplished in various ways. In general, there are two presently preferred solutions (explicit signalling and implicit signalling), both of which can be exploited in accordance with the teachings of this invention.

Explicit Signalling

15 A first approach is referred to as explicit signaling, wherein several new parameters are added to the existing signalling information elements. The following is a general description of the signalling changes in accordance with one preferred embodiment.

20 Classmark:

In one embodiment the mobile station 12 indicates in a Classmark_Change message its full or partial support for EDGE. More specifically, the mobile station 12 indicates one of two possibilities for using additional modulation (e.g., 8-PSK) in addition to the normal modulation
25 (e.g., GMSK):

1. The additional modulation is supported for uplink transmission and downlink reception
2. The additional modulation is supported for downlink reception only.

30

Call Control

In order to indicate the preference for asymmetric service by the mobile station 12, at least two bits are provided in a field of a Bearer

Capability Information Element. The Setup message is one type of message capable of carrying this Information Element. One exemplary use of codepoints in this Information Element is as follows:

5	<u>Bit</u>	<u>1</u>	<u>2</u>	
		1	0	Downlink biased channel coding asymmetry is preferred
		0	1	Uplink biased channel coding asymmetry is preferred
		0	0	Channel coding symmetry preferred
10		1	1	Unused, if received this bit combination is interpreted as "Channel coding symmetry preferred"

In addition to the foregoing, there may be additional codepoints in other signalling messages, such as the WAIUR (Wanted Air Interface User Rate), that can be employed for this purpose.

15

Also, the user of the mobile station 12 or the wireless network may choose to switch to an asymmetric service during a call that was initiated as a symmetric call, or vice versa. This can be accomplished by using, for example, a Modify procedure that includes the Bearer Capability Information Element, as modified above.

20

Radio Resource

In GSM the BSC 16 is responsible for the radio resource management (RR Management software module 16A), and makes use of different signaling messages for handling the radio resources. An example depicted in Fig. 2 shows the use of a Channel Activation message during a mobile originated (MO) call. In order to support the asymmetric service there is a need for a definition of new channel modes.

25

Referring to Fig. 1, one embodiment defines the channel modes as follows (UL+DL):

30

For the Downlink (DL) biased mode of operation:

- Assym_mode 1: 14.5 + 43.5
- 35 Assym_mode 2: 14.5 + 28.8
- Assym_mode 3: 28.8 + 43.5

For the Uplink (UL) biased mode of operation:

Assym_mode 4: 43.5 + 14.5

Assym_mode 5: 28.8 + 14.5

Assym_mode 6: 43.5 + 28.8

5 A interface

The information that the MSC 18 obtains from the mobile station 12 via the Classmark_Change message is used during the assignment procedure in order to support asymmetric services. This embodiment thus requires changes to the Information Elements in the messages on the A
10 interface 18A. One example is shown in Fig. 2 for an Assignment Request message.

Implicit Signalling

Turning now to the case where the mobile station 12 does support 8-
15 PSK modulation in the uplink, it is preferred that the wireless network rely on the blind detection of the modulation by the BTS 14, which then informs, if necessary, the BSC 16 of the channel mode used on the air interface. This is considered to be implicit signalling, as the modulation type is determined (detected) directly from the mobile station transmissions, without requiring
20 explicit signalling.

The blind detection or identification of the uplink modulation can be based on the different phase rotation characteristics of the 8-PSK modulation and the GMSK modulation. More specifically, in GMSK a
25 continuous $\pi/2$ rotation is defined, while in 8-PSK a continuous $3\pi/8$ rotation is defined (see, for example, GSM 05.02 and 05.04). Based on these differences, the uplink modulation can be reliably identified in the BTS 14 receiver, without prior knowledge (i.e., no additional signaling is required) about the modulation used in the transmitter of the mobile station 12.

30

An example of the embodiment wherein the mobile station 12 does support 8-PSK in the uplink is shown in the implicit signalling case of Fig. 3. In this example, the mobile station 12 uses the Classmark_Change Information Element to inform the network of its modulation capabilities. The

network is then aware that the mobile station 12 is 8-PSK capable for both the uplink and the downlink. If the network decides to allow the use of asymmetry then the BSC 16 employs the Channel Activation and Assignment Command messages (in this example) to allow the asymmetry.

5 In this case the mobile station 12 transmits on the uplink at any rate allowed. For example, and referring again to Fig. 1, if the downlink data rate is 43.5 kbps, then the MS can transmit on the uplink either at 14.5 kbps or 43.5 kbps.

10 Various reasons for changing the mode of the channel uplink could be based on (a) the link adaptation algorithm in the mobile station 12, (b) if the link budget is not sufficient for using the additional modulation (e.g., 8-PSK) in the uplink, or (c) if the application does not require a high bit rate transmission capability in the uplink.

15

For the case where the downlink link budget does not support the second modulation, various reasons for changing the mode of the channel downlink could be based on (a) the link adaptation algorithm, (b) if the link budget is not sufficient for using the additional modulation (e.g., 8-PSK) in the downlink, or (c) if the application does not require a high bit rate transmission capability in the downlink.

20

The signaling for the asymmetric case can be the same as for the symmetric case, with the exception that the Classmark 3 Information Element (IE) can be used for deriving the appropriate asymmetric mode.

25

It is preferred that the mobile station 12 uses an algorithm that prevents frequent changes of the uplink mode during a call. Every time the uplink mode changes, the BTS 14 may inform the BSC 16 of the change.

30 An example of this is shown in Fig. 3, where an Uplink Channel Mode message is used for the purpose of informing the BSC 16 of the change in the channel mode uplink. Alternatively, an Information Element in one of the messages from the BTS 14 to the BSC 16, such as a Measurement Results

message, can be used for signalling the change in the uplink mode of the mobile station 12. It is noted that are cases when the BSC 16 is or should be aware of the changes in the uplink mode, such as is the case when power control is used for extended range operation.

5

Also, it should be appreciated that a lower data rate may be desired on the uplink in order to reduce the power consumption of the mobile station 12, and/or in the downlink direction to avoid unnecessary interference. This is especially true in the case that one direction or the other has less data to
10 transmit, and the high speed data transmission mode is not required (even if supported).

As was stated above, while the invention has been described in the context of a TDMA-type system (e.g., GSM), it should be appreciated that
15 aspects of this invention may be extended to other types of systems such as, but not limited to, CDMA systems. Furthermore, the teachings of this invention are not limited for use with only circuit-switched embodiments, but have wider applicability.

20 Also, and under the third condition discussed previously, it is within the scope of this invention for the mobile station 12 to automatically start transmission with the normal modulation (e.g., GMSK), and the BTS 14 may optionally be informed by the BSC 16 of this mode of operation so that blind detection of the uplink modulation type is not required by the BTS 14. That
25 is, while it may be presently preferred that the mobile station 12 not change its mode without being commanded through explicit signalling, and thus not perform link adaptation, it is within the scope of these teachings to provide a capability for the mobile station 12 to operate in this manner.

30 Thus, while the invention has been particularly shown and described with respect to preferred embodiments thereof, it will be understood by those skilled in the art that changes in form and details may be made therein without departing from the scope and spirit of the invention.

What is claimed is:

1. A method for supporting data transmission services in a digital wireless communication system that operates with a first type of modulation
5 between a mobile station and a wireless network, comprising steps of:

bidirectionally coupling a mobile station to the network through a radio interface; and

10 in a first case, applying a second, different type of modulation in a downlink direction from the network to the mobile station unless at least one of a plurality of conditions are found to apply, while

in a second case, applying a second, different type of modulation in
15 an uplink direction from the mobile station to the network unless one of the plurality of conditions are found to apply.
2. A method as in claim 1, wherein one of said conditions is that the second type of modulation is supported in the network, but is not
20 supported in both directions by the mobile station.
3. A method as in claim 1, wherein one of said conditions is that a user specifically requests a downlink biased data link service, which is also used by the mobile station in the uplink, and wherein the modulation type is
25 implicitly detected by the network from received uplink mobile station transmissions.
4. A method as in claim 1, wherein one of said conditions is that a user specifically requests an uplink biased data link service, which is also
30 used by the mobile station in the downlink, and wherein the modulation type is implicitly detected by the network from received uplink mobile station transmissions.

5. A method as in claim 1, wherein one of said conditions is that the mobile station supports the second type of modulation, but uplink conditions restrict the use of the second type of modulation, while another one of said conditions is that the mobile station supports the second type of modulation. but downlink conditions restrict the use of the second type of modulation.

6. A method as in claim 1, wherein an uplink data rate is caused to differ from a downlink data rate in order to at least one of reduce a power consumption of the mobile station, or to reduce an amount of interference in the downlink direction.

7. A method as in claim 1, wherein for any of the plurality of conditions the same L3 protocol is applied for data transmission in both the downlink and the uplink.

8. A method as in claim 1, wherein one of the modulation types is 8-PSK modulation, wherein another of the modulation types is GMSK modulation, and wherein the uplink and the downlink operate with the same or with different data rates.

9. A method as in claim 1, wherein the mobile station indicates to the network in a message that the second type of modulation is supported for both uplink transmission and downlink reception, or that the second type of modulation is supported for downlink reception only.

10. A method as in claim 9, wherein the message is Classmark_Change message.

11. A method as in claim 1, wherein the mobile station explicitly indicates to the network one of the following: that downlink biased channel coding asymmetry is preferred, that uplink biased channel coding asymmetry is preferred, or that channel coding symmetry preferred.

12. A method as in claim 11, wherein the mobile station explicitly indicates to the network in a message having a Bearer Capability Information Element.

5

13. A method as in claim 1, wherein the mobile station explicitly indicates to the network one of two conditions for using an additional type of modulation, in addition to a normal type of modulation: (a) the additional type of modulation is supported for uplink transmission and downlink reception; or
 10 (b) the additional type of modulation is supported for downlink reception only.

14. A method as in claim 13, wherein the mobile station explicitly indicates to the network the one of the two conditions in a Classmark_Change message.

15

15. A method as in claim 1, wherein the mobile station explicitly indicates to the network a preference for asymmetric service using a first bit and a second bit in an Information Element.

20

16. A method as in claim 15, wherein the Information Element is a Bearer Capability Information Element.

17. A method as in claim 15, wherein the Information Element is a Bearer Capability Information Element in a Setup message.

25

18. A method as in claim 1, wherein the mobile station explicitly indicates to the network a preference for one of asymmetric service or symmetric service using a first bit and a second bit in an Information Element as follows:

30

<u>Bit</u>	<u>1</u>	<u>2</u>	
	1	0	downlink biased channel coding asymmetry is preferred,
35	0	1	uplink biased channel coding asymmetry is preferred.

0 0 and
channel coding symmetry preferred.

5 19. A method as in claim 1, wherein if both the first and the second bits are set, the network interprets the Information Element as specifying that channel coding symmetry preferred.

10 20. A method as in claim 15, wherein the Information Element is sent in a WAIUR (Wanted Air Interface User Rate) message.

15 21. A method as in claim 1, and comprising a further step of switching to an asymmetric service during a call that was initiated as a symmetric call.

22. A method as in claim 21, wherein the mobile station explicitly indicates to the network a preference for switching to the asymmetric service using a first bit and a second bit in an Information Element as follows:

20	<u>Bit</u>	<u>1</u>	<u>2</u>	
		1	0	downlink biased channel coding asymmetry is preferred, and
		0	1	uplink biased channel coding asymmetry is preferred.

25

23. A method as in claim 22, wherein the Information Element is a Bearer Capability Information Element.

30 24. A method as in claim 1, and comprising a further step of switching to a symmetric service during a call that was initiated as an asymmetric call.

35 25. A method as in claim 24, wherein the mobile station explicitly indicates to the network a preference for switching to the symmetric service using a first bit and a second bit in an Information Element.

26. A method as in claim 25, wherein the Information Element is a Bearer Capability Information Element.

5 27. A digital wireless communication system that supports digital data communications and that operates with a first type of modulation between a mobile station and a wireless network, comprising:

10 a wireless interface for bidirectionally coupling the mobile station to the network; and

control circuitry operable in a first case for applying a second, different type of modulation in a downlink direction from the network to the mobile station unless at least one of a plurality of conditions are found to apply, while

15

in a second case, applying a second, different type of modulation in an uplink direction from the mobile station to the network unless one of the plurality of conditions are found to apply.

20

28. A system as in claim 27, wherein one of said conditions is that the second type of modulation is supported in the network, but is not supported in both directions by the mobile station, wherein another one of said conditions is that a user specifically requests one of a downlink biased data link service or an uplink biased data link service, which is also used by the mobile station in the uplink or the downlink, respectively, and at least the modulation type of which is detected by the network from received uplink mobile station transmissions, and wherein another one of said conditions is that the mobile station supports the second type of modulation, but either uplink or downlink conditions restrict the use of the second type of modulation.

25

30

29. A method as in claim 27, wherein for any of the plurality of

conditions the same L3 protocol is applied for data transmission in both the downlink and the uplink.

30. A system as in claim 27, wherein one of the modulation types
5 is 8-PSK modulation, and wherein another of the modulation types is GMSK modulation.

31. A system as in claim 27, wherein the mobile station explicitly
indicates to the network in a Information Element that the second type of
10 modulation is supported for both uplink transmission and downlink reception,
or that the second type of modulation is supported for downlink reception
only, and further explicitly indicates to the network that downlink biased
channel coding asymmetry is preferred, or that uplink biased channel coding
asymmetry is preferred, or that channel coding symmetry preferred.

15

32. A system as in claim 27, wherein said control circuitry switches
to an asymmetric service during a call that was initiated as a symmetric call,
or switches to a symmetric service during a call that was initiated as an
asymmetric call.

20

33. A method for supporting data transmission services in a digital
wireless communication system, comprising steps of:

bidirectionally coupling a mobile station to the network through a radio
25 interface; and

explicitly signalling to the network a preference for one of asymmetric
service or symmetric service using predetermined bits in an
Information Element.

30

34. A method as in claim 33, wherein the Information Element is a
Bearer Capability Information Element.

35. A method as in claim 33, wherein the Information Element is a Bearer Capability Information Element in a Setup message.

36. A method as in claim 33, wherein the mobile station explicitly signals to the network a preference for asymmetric service or symmetric service using a first bit and a second bit in an Information Element as follows:

10	<u>Bit</u>	<u>1</u>	<u>2</u>	
		1	0	downlink biased channel coding asymmetry is preferred,
		0	1	uplink biased channel coding asymmetry is preferred, and
15		0	0	channel coding symmetry preferred.

37. A method as in claim 36, wherein if both the first and the second bits are set, the network interprets the Information Element as specifying that channel coding symmetry preferred.

38. A method as in claim 33, wherein the mobile station explicitly signals to the network one of two conditions for using a different type of modulation than a normal type of modulation: (a) the additional type of modulation is supported for uplink transmission and downlink reception; or (b) the additional type of modulation is supported for downlink reception only.

39. A method as in claim 33, wherein implicit signalling is used to cause an uplink data rate to differ from a downlink data rate in order to at least one of reduce power consumption of the mobile station, or to reduce an amount of interference in the downlink direction.

40. A method as in claim 33, wherein implicit signalling is based on range considerations.

1/2

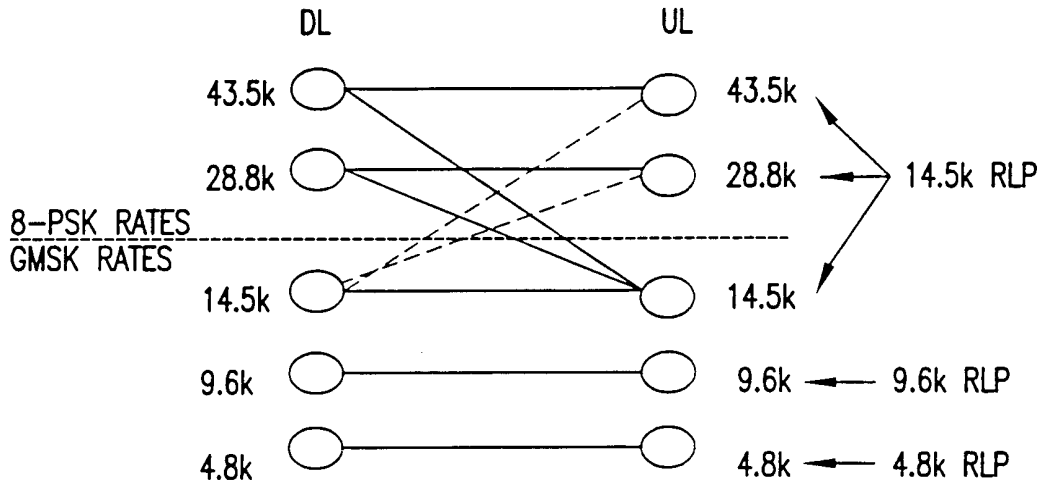

FIG. 1

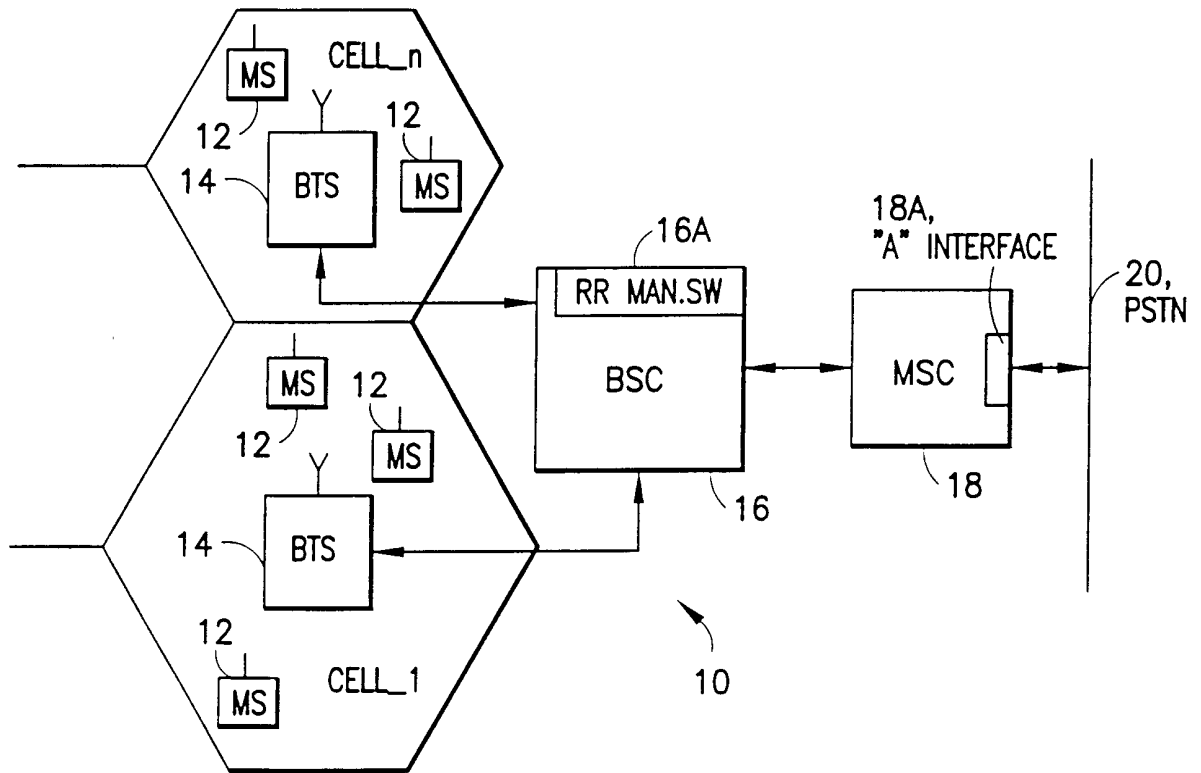

FIG. 4

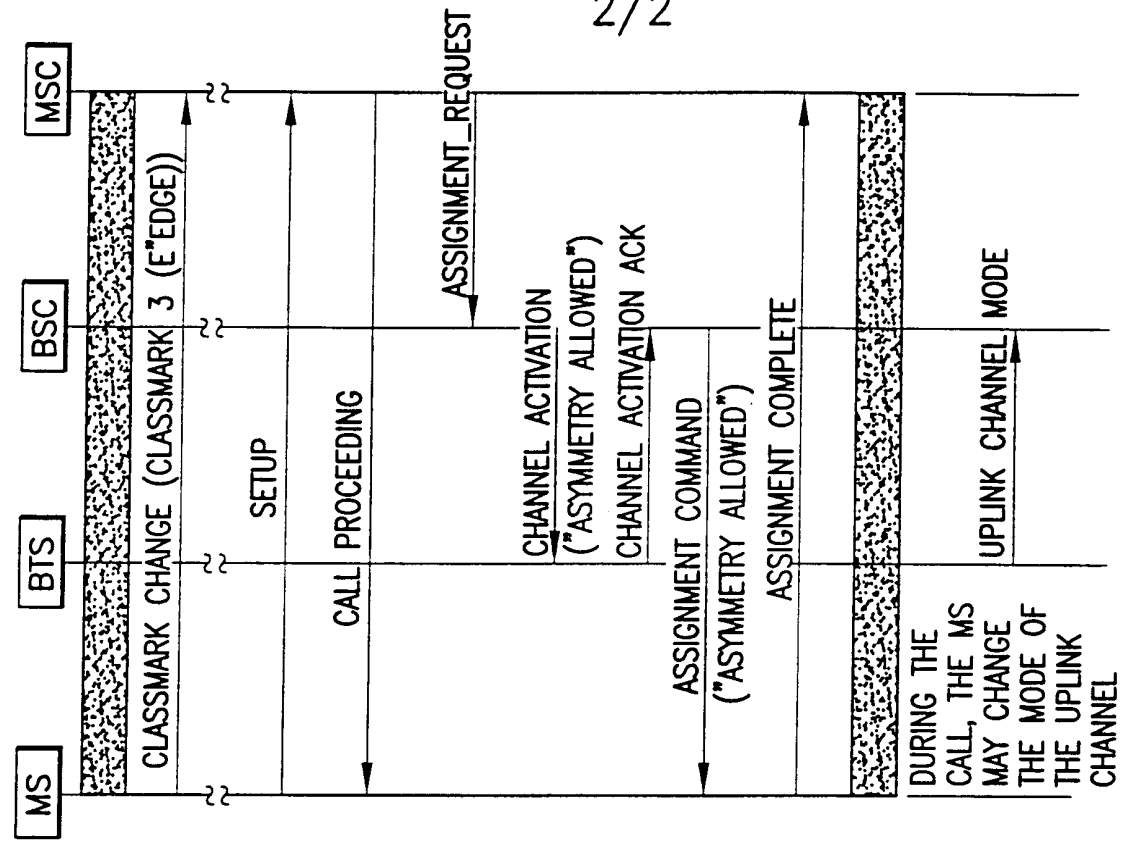

FIG.2

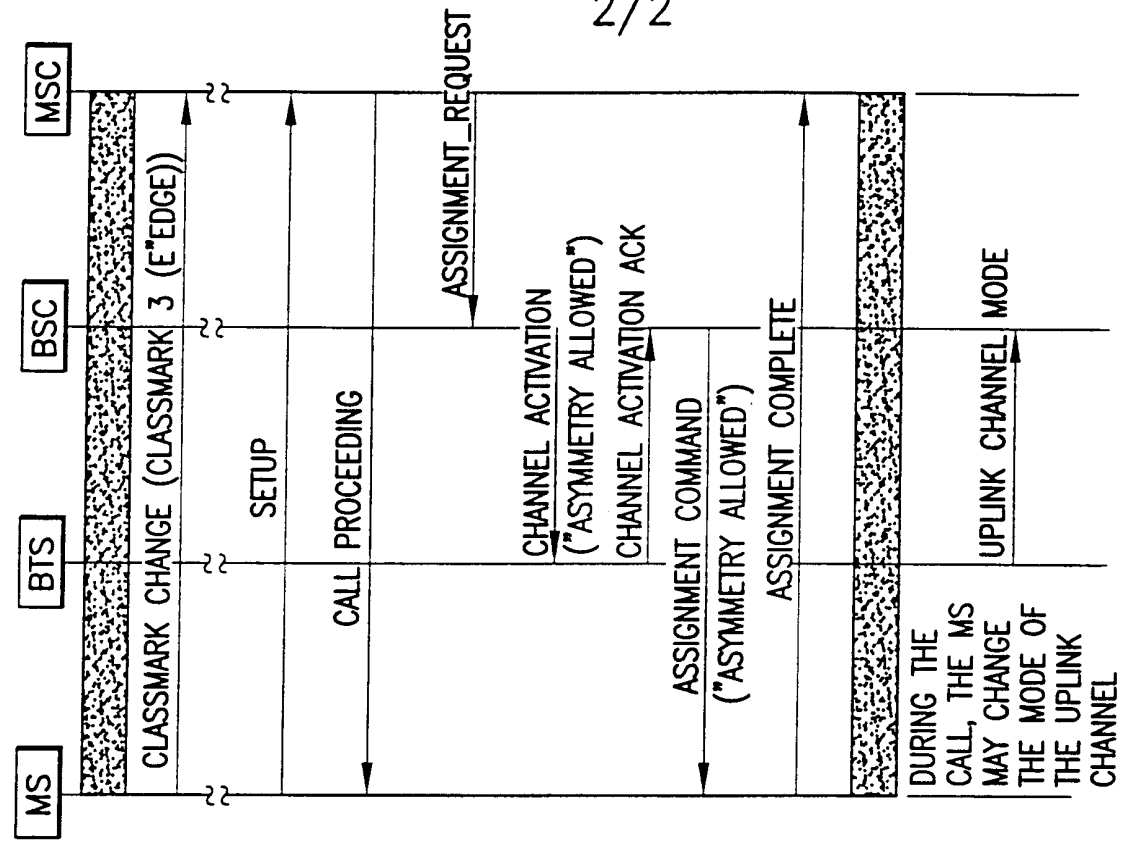

FIG.3

INTERNATIONAL SEARCH REPORT

International application No. PCT/US00/11953

A. CLASSIFICATION OF SUBJECT MATTER
 IPC(7) : HO4Q 7/20
 US CL : 455/110
 According to International Patent Classification (IPC) or to both national classification and IPC

B. FIELDS SEARCHED
 Minimum documentation searched (classification system followed by classification symbols)
 U.S. : 455/110

Documentation searched other than minimum documentation to the extent that such documents are included in the fields searched
 455/110, 375/271, 259, 341, 269, 262, 219, 9, 222; 370/465, 468

Electronic data base consulted during the international search (name of data base and, where practicable, search terms used)
 West 2

C. DOCUMENTS CONSIDERED TO BE RELEVANT

Category*	Citation of document, with indication, where appropriate, of the relevant passages	Relevant to claim No.
X	US 5,537,672 A (GRABOW et al.) 16 July 1996, col. 3 lines 8-43.	1-35
X	US 5,673,291 A (DENT) 30 September 1997, col. 12 lines 5-33	8, 30
X	US 6,005,957 A (HONKASALO et al.) 21 December 1999, col. 5 lines 46-52.	12, 16, 17, 23, 26, 34, 35,

Further documents are listed in the continuation of Box C. See patent family annex.

<p>* Special categories of cited documents</p> <p>*A* document defining the general state of the art which is not considered to be of particular relevance</p> <p>*E* earlier document published on or after the international filing date</p> <p>*L* document which may throw doubts on priority claim(s) or which is cited to establish the publication date of another citation or other special reason (as specified)</p> <p>*O* document referring to an oral disclosure, use, exhibition or other means</p> <p>*P* document published prior to the international filing date but later than the priority date claimed</p>	<p>*T* later document published after the international filing date or priority date and not in conflict with the application but cited to understand the principle or theory underlying the invention</p> <p>*X* document of particular relevance: the claimed invention cannot be considered novel or cannot be considered to involve an inventive step when the document is taken alone</p> <p>*Y* document of particular relevance: the claimed invention cannot be considered to involve an inventive step when the document is combined with one or more other such documents, such combination being obvious to a person skilled in the art</p> <p>*Z* document member of the same patent family</p>
---	---

Date of the actual completion of the international search 11 JULY 2000	Date of mailing of the international search report 11 AUG 2000
---	--

Name and mailing address of the ISA/US Commissioner of Patents and Trademarks Box PCT Washington, D.C. 20231 Facsimile No. (703) 305-3230	Authorized officer <i>James R. Matthews</i> YEMANE WOLDETATIOS Telephone No. (703) 308-9596
---	---

INTERNATIONAL SEARCH REPORT

International application No.
PCT/US00/11953

C (Continuation). DOCUMENTS CONSIDERED TO BE RELEVANT		
Category*	Citation of document, with indication, where appropriate, of the relevant passages	Relevant to claim No.
Y	US 5,537,672 A (GRABOW et al.) 16 July 1996, col. 3 lines 8-43.	6
X,E	US 6,088,430 A (McHALE) 11 July 2000, col. 5 lines 56-62	6
A	US 5,602,868 A (WILSON) 11 February 1997	2-5, 9, 11, 13, 14,
A	US 6,052,408 A (TROMPOWER et al., 18 April 2000	15, 18-22, 24, 25,
A	US 5,943,344 A (KELLER et al.) 24 August 1999	28, 31, 32, 33, 36-40
Y	US 6,035,212 A (ROSTOKER et al.) 07 March 2000, col. 14 lines 19-28	7, 29
Y	US 5,960354 A (EINOLA) 28 September 1999, col. 5 lines 53-63	10