

June 19, 1923.

1,459,333

G. HIPWOOD

CRUTCH

Original Filed March 11, 1919

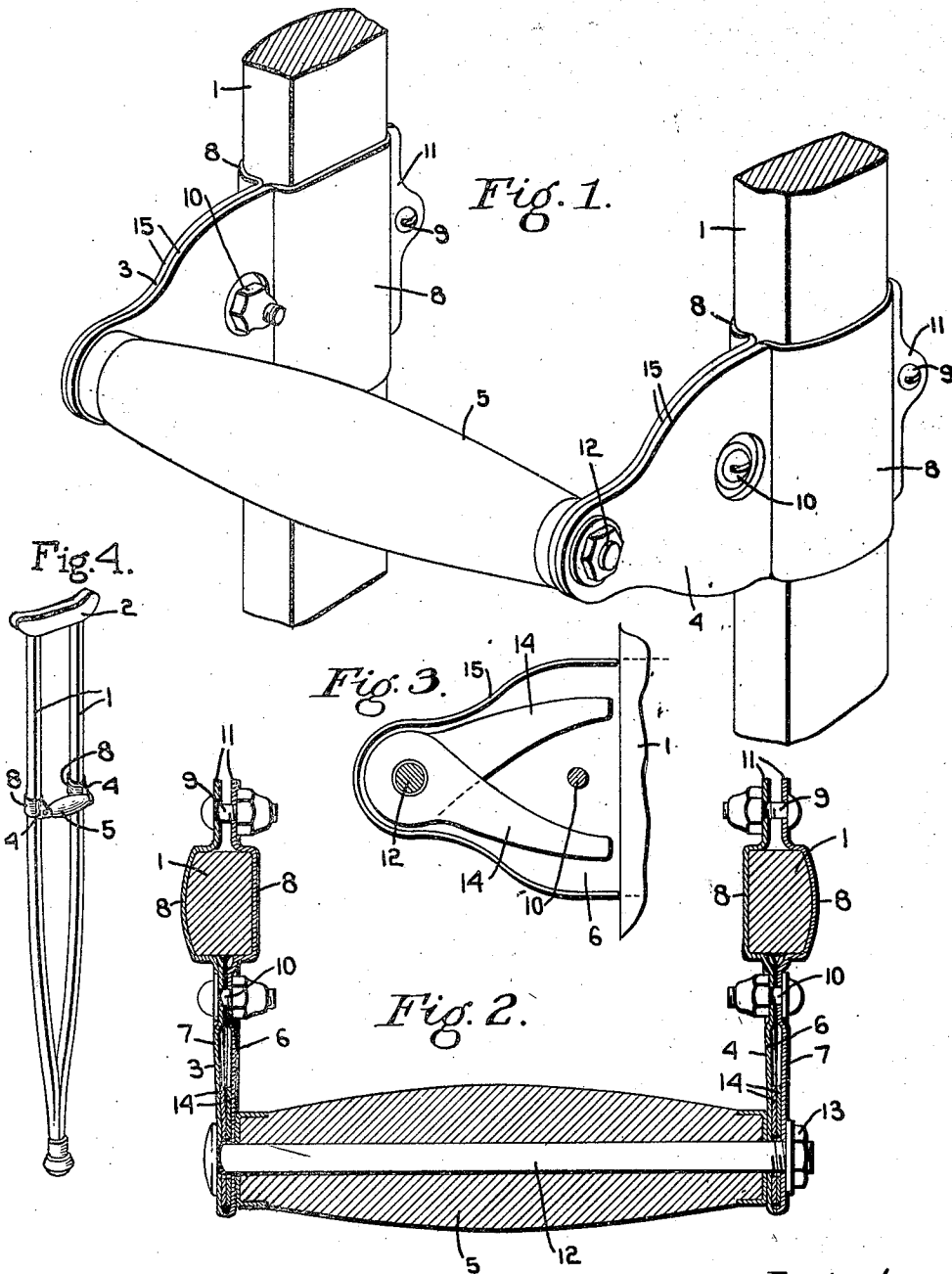

Inventor:  
George Hipwood,  
by Heard Smith & Tennant  
Attys.

## UNITED STATES PATENT OFFICE.

GEORGE HIPWOOD, OF NEW YORK, N. Y.

## CRUTCH.

Application filed March 11, 1919, Serial No. 281,941. Renewed November 15, 1922. Serial No. 601,167.

To all whom it may concern:

Be it known that I, GEORGE HIPWOOD, a citizen of the United States, residing at New York, county of New York, State of New York, have invented an Improvement in Crutches, of which the following description, in connection with the accompanying drawing, is a specification, like characters on the drawing representing like parts.

This invention relates to crutches and particularly to the handle therefor. The objects of the invention are to provide an improved crutch handle which can be readily applied to any ordinary crutch; which is constructed so that it can be adjusted up and down on the crutch thereby to be placed in the position most convenient for the user, and which is constructed so that the handle portion which is grasped in the hand of the user is situated at one side of the crutch body so that it is not necessary for the user to turn the hand inwardly toward the body in using the crutch, and otherwise to improve crutch handles, all as will be more fully hereinafter set forth.

In order to give an understanding of my invention, I have illustrated in the drawings a selected embodiment thereof which will now be described, after which the novel features will be pointed out in the appended claims.

In the drawings, Fig. 1 is a perspective view of a portion of a crutch body showing my improved handle applied thereto;

Fig. 2 is a horizontal section through the handle and crutch body;

Fig. 3 is a sectional view taken in a vertical plane between the two plates comprising one bracket;

Fig. 4 is a perspective view of a crutch having my improved handle applied thereto.

My improved handle is especially designed to be used in connection with the type of crutch shown in Fig. 4 which comprises the two side members 1 on which the arm rest 2 is supported. My improved handle comprises two handle-supporting brackets, each adapted to be adjustably clamped to one of the side members 1, and a handle portion sustained by said brackets. The two brackets are indicated at 3 and 4, respectively, and the handle portion is indicated generally at 5. Each bracket comprises two plates 6 and 7, each plate having a groove or recess 8 extending transversely thereof which is adapted to receive one of the side members

1 of the crutch body. These recessed portions 8 will be of a shape to fit the side member 1, and means are provided for clamping the two plates of each bracket together thereby clamping them firmly to the side members 1. The means herein shown for this purpose comprises two clamping screws 9 and 10, the clamping screw 10 extending through the two plates on the outer side of the crutch body and the clamping screw 9 extending through ears or projections 11 formed on the plates at the inner side of said crutch body. When these clamping screws 9 and 10 are tightened, the two plates of each bracket will be firmly clamped to the side member 1. The handle portion 5 is shown as sustained on a rod 12 which in turn is secured to the outer ends of the two brackets 3 and 4. This rod extends through both brackets and through the handle 5 and is provided with a nut 13 on one end by which the handle is firmly clamped between the brackets.

By means of this construction the handle can be adjusted vertically of the crutch, for if the clamping screws 9 and 10 are loosened, each bracket will be sufficiently free from the crutch body so that it can be moved up or down as desired, and when it is in the proper position, the tightening of the screws 9, and 10 will firmly clamp it in place. I may if desired interpose one or more spring members 14 between each pair of plates 6 and 7, said spring members tending to press the plates apart slightly. The advantage of these spring members is that when the clamping screws are loosened, they will operate automatically to separate the plates so that they can be readily adjusted on the crutch body.

The plates 6 and 7 are preferably spaced slightly from each other sufficiently to receive the spring members 14, and the edges of the plates are bent inwardly to form flanges 15, the flanges on two plates meeting each other and forming a closed edge. My improved handle has the advantage that it can be applied to any crutch body and may be placed in the position most convenient for the user of the crutch. Further, since the handle portion 5 is supported at the outer ends of the brackets, said handle will be in position where the user can grasp it without the necessity of bending his wrist inwardly to bring the hand in the plane of the crutch body.

I claim:

1. In a crutch, the combination with a crutch body having two side members, of two separate handle-supporting brackets, one secured to each side member, each bracket comprising a pair of plates which are wider at one end than at the other, each plate having a groove at its wider end to receive a side member of the crutch and having a peripheral stiffening flange at the other end, the flanges of the plates of each pair having an abutting relation, clamping screws for clamping together the plates of each pair, the screws for each bracket being situated on opposite sides of the side member of the crutch, a handle member interposed between the brackets at the narrow ends thereof, and

a rod extending through both brackets and through said handle member and clamping the handle firmly between the brackets. 20

2. A handle for a crutch having two handle-supporting brackets, each bracket comprising two plates, each having a portion formed to embrace a side member of a crutch, clamping screws for clamping the plates to said side member, a handle secured to said brackets, and spring elements situated between the plates of each bracket and tending to separate them as the clamping screws are loosened. 25 30

In testimony whereof, I have signed my name to this specification.

GEORGE HIPWOOD.