



US00D495283S1

(12) **United States Design Patent** (10) **Patent No.:** **US D495,283 S**
Ashley et al. (45) **Date of Patent:** **** Aug. 31, 2004**

(54) **VEHICLE STEP**

(75) Inventors: **Larry Wayne Ashley**, Ontario, CA (US); **Jeremy Ray Hayter**, Fontana, CA (US)

(73) Assignee: **American Products Company, Inc.**, Corona, CA (US)

(**) Term: **14 Years**

(21) Appl. No.: **29/196,872**

(22) Filed: **Jan. 7, 2004**

(51) **LOC (7) Cl.** **12-16**

(52) **U.S. Cl.** **D12/203**

(58) **Field of Search** D12/203, 202, D12/190, 85, 87, 400; 280/163, 164.1, 848, 169, 153.5, 607; 180/182-185, 190, 193; 296/203-204, 196-197; 428/81-82

(56) **References Cited**

U.S. PATENT DOCUMENTS

1,357,593 A	11/1920	Rouanet	
1,519,751 A	12/1924	Baker	
1,759,212 A	5/1930	Wasserfallen	
1,848,975 A	3/1932	Proctor	
3,715,066 A	2/1973	Owen	
4,561,575 A	12/1985	Jones	
D289,030 S	3/1987	Bowman D12/202
D293,229 S	12/1987	Smith D12/162
4,915,274 A	4/1990	Oliver	
D320,592 S	* 10/1991	Straka D12/203
5,080,269 A	1/1992	Larsson et al.	
D340,905 S	* 11/1993	Orth, Sr. et al. D12/203
D345,337 S	3/1994	Feller D12/202
D349,679 S	* 8/1994	Waddington et al. D12/203
D355,632 S	2/1995	Padgett D12/202
D361,973 S	* 9/1995	Hornik D12/203

5,469,998 A	11/1995	Van Dusen et al.	
D395,269 S	* 6/1998	McCauley, Jr. D12/203
D400,151 S	* 10/1998	Zentner D12/203
D400,485 S	* 11/1998	Zentner D12/203
D402,611 S	* 12/1998	Thomas, Jr. D12/203
6,050,579 A	* 4/2000	Selland et al. 280/163
D444,754 S	* 7/2001	Storer D12/203
D474,435 S	* 5/2003	Lund et al. D12/203

* cited by examiner

Primary Examiner—Stacia Cadmus

(74) *Attorney, Agent, or Firm*—Knobbe, Martens, Olson & Bear LLP

(57) **CLAIM**

The ornamental design for a vehicle step, as shown and described.

DESCRIPTION

FIG. 1 is a front/left-side perspective view of the vehicle step according to the present design;

FIG. 2 is a front elevational view of the vehicle step of FIG. 1;

FIG. 3 is a top plan view of the vehicle step of FIG. 1;

FIG. 4 is a bottom plan view of the vehicle step of FIG. 1;

FIG. 5 is a rear elevational view of the vehicle step of FIG. 1;

FIG. 6 is an enlarged right-side elevational view of the vehicle step of FIG. 1;

FIG. 7 is an enlarged left-side elevational view of the vehicle step of FIG. 1; and,

FIG. 8 is a front/left-side perspective view of the vehicle step of FIG. 1, illustrating the vehicle step secured to a vehicle.

The broken line showing of environment is for illustrative purposes only and forms no part of the claimed design.

1 Claim, 5 Drawing Sheets

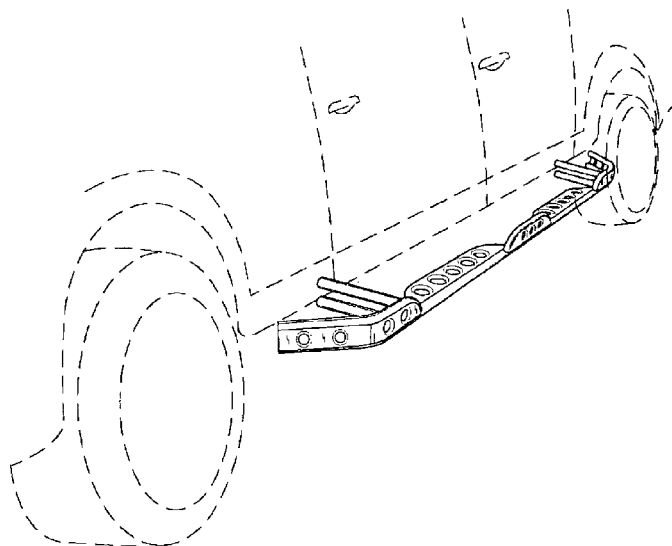

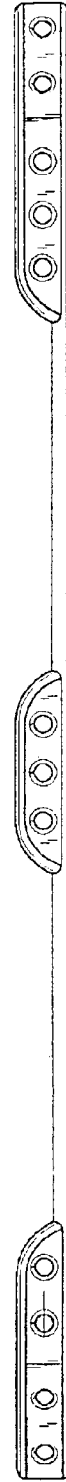
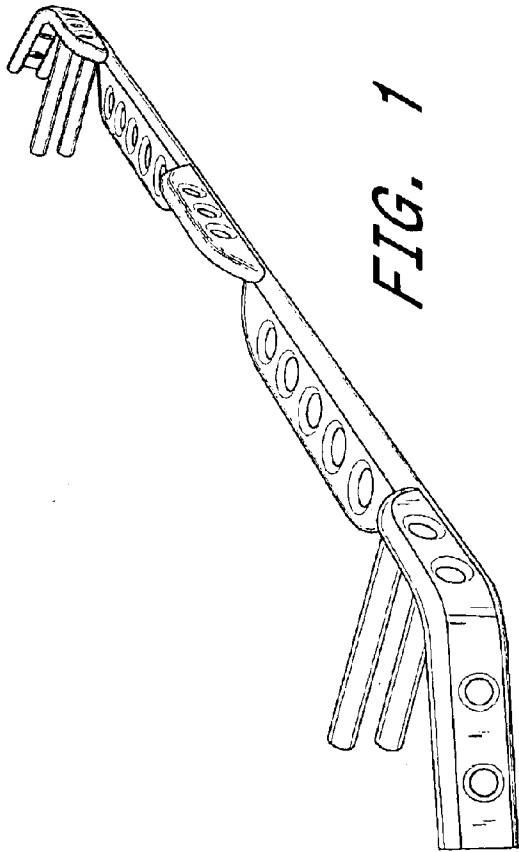

FIG. 3

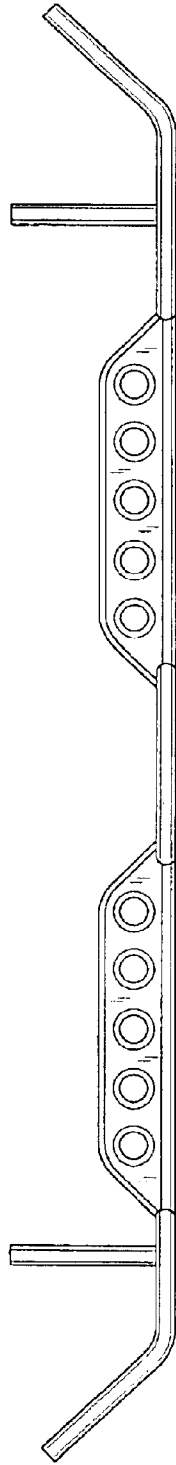

FIG. 4

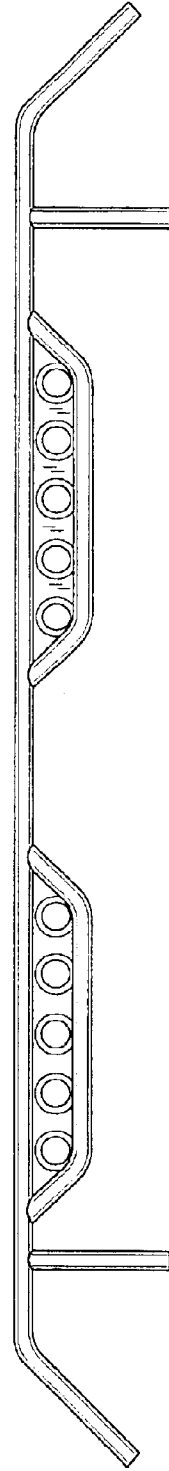



FIG. 5

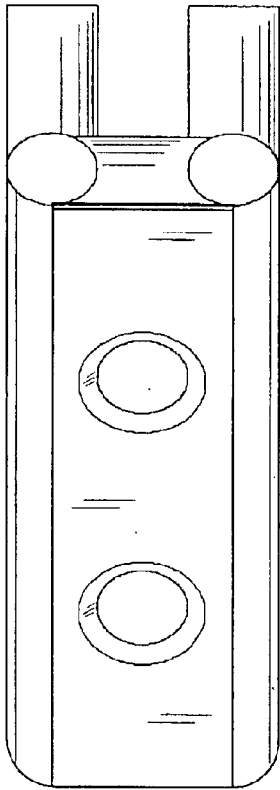

FIG. 6

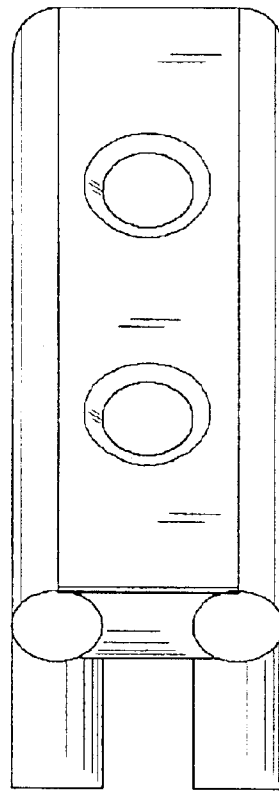

FIG. 7

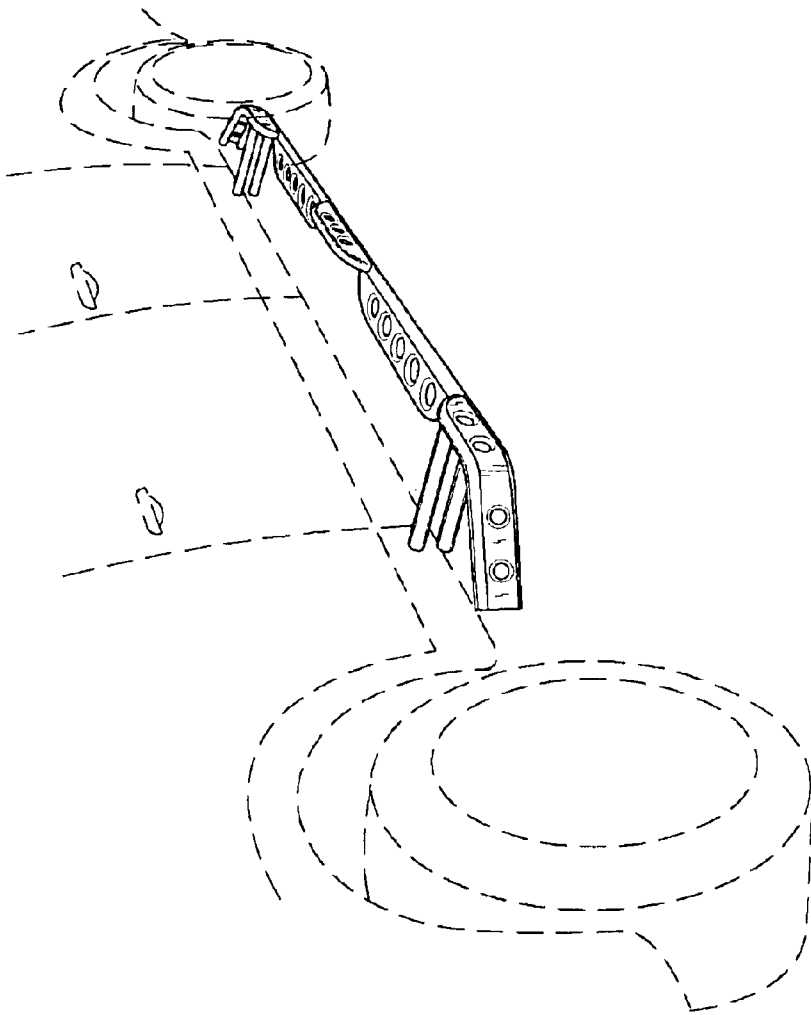

FIG. 8