



- (51) International Patent Classification: 92037 (US). ENGINEERING ARTS LLC [US/US]; 2702 E. Verbena Drive, Phoenix, AZ 85048 (US).
G01N 1/28 (2006.01) H01J 37/26 (2006.01)
- (21) International Application Number: PCT/US2013/000019 (72) Inventors; and (71) Applicants : CARRAGHER, Bridget [US/US]; 9584 Whellock Way, San Diego, CA 92129 (US). POTTER, Clinton, S. [US/US]; 4380 Argos Drive, San Diego, CA 92116 (US). JAIN, Tilak [IN/US]; 165 Sanford Street, Encinitas, CA 92024 (US). KAHN, Peter [US/US]; 2702 E. Verbena Drive, Phoenix, AZ 85048 (US). WIKTOR, Peter [US/US]; 3902 Bronco Trail, Phoenix, AZ 85044 (US).
- (22) International Filing Date: 14 January 2013 (14.01.2013) (74) Agent: FITTING, Thomas; The Scripps Research Institute, 10550 North Torrey Pines Road, TPC-8, La Jolla, CA 92037 (US).
- (25) Filing Language: English
- (26) Publication Language: English
- (30) Priority Data: 61/632,047 17 January 2012 (17.01.2012) US
- (71) Applicants: THE SCRIPPS RESEARCH INSTITUTE [US/US]; 10550 North Torrey Pines Road, La Jolla, CA

[Continued on next page]

(54) Title: APPARATUS AND METHOD FOR PRODUCING SPECIMENS FOR ELECTRON MICROSCOPY

(57) Abstract: The invention provides methods and devices for preparing frozen vitrified samples for transmission electron microscopy. By reducing the volume of sample from microliter scale to picoliter scale, the requirement for blotting of excess fluid is minimized or eliminated.

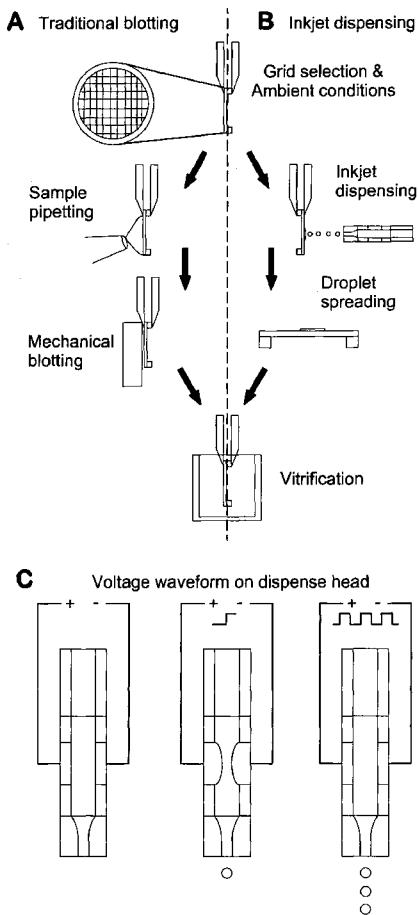

FIG. 1





(81) Designated States (unless otherwise indicated, for every kind of national protection available): AE, AG, AL, AM, AO, AT, AU, AZ, BA, BB, BG, BH, BN, BR, BW, BY, BZ, CA, CH, CL, CN, CO, CR, CU, CZ, DE, DK, DM, DO, DZ, EC, EE, EG, ES, FI, GB, GD, GE, GH, GM, GT, HN, HR, HU, ID, IL, IN, IS, JP, KE, KG, KM, KN, KP, KR, KZ, LA, LC, LK, LR, LS, LT, LU, LY, MA, MD, ME, MG, MK, MN, MW, MX, MY, MZ, NA, NG, NI, NO, NZ, OM, PA, PE, PG, PH, PL, PT, QA, RO, RS, RU, RW, SC, SD, SE, SG, SK, SL, SM, ST, SV, SY, TH, TJ, TM, TN, TR, TT, TZ, UA, UG, US, UZ, VC, VN, ZA, ZM, ZW.

(84) Designated States (unless otherwise indicated, for every kind of regional protection available): ARIPO (BW, GH,

GM, KE, LR, LS, MW, MZ, NA, RW, SD, SL, SZ, TZ, UG, ZM, ZW), Eurasian (AM, AZ, BY, KG, KZ, RU, TJ, TM), European (AL, AT, BE, BG, CH, CY, CZ, DE, DK, EE, ES, FI, FR, GB, GR, HR, HU, IE, IS, IT, LT, LU, LV, MC, MK, MT, NL, NO, PL, PT, RO, RS, SE, SI, SK, SM, TR), OAPI (BF, BJ, CF, CG, CI, CM, GA, GN, GQ, GW, ML, MR, NE, SN, TD, TG).

Published:

- with international search report (Art. 21(3))
- before the expiration of the time limit for amending the claims and to be republished in the event of receipt of amendments (Rule 48.2(h))

APPARATUS AND METHOD FOR PRODUCING SPECIMENS FOR ELECTRON MICROSCOPY

BACKGROUND OF THE INVENTION

[0001] The following discussion of the background of the invention is merely provided to aid the reader in understanding the invention and is not admitted to describe or constitute prior art to the present invention.

[0002] Molecular microscopy is a non-invasive electron imaging technology that uses advanced specimen preparation and imaging methods designed specifically to visualize complex biological samples, under conditions close to their native state. Samples are preserved in a very thin film of solution on an EM grid by vitrification (using an automated cryogenic robot) or by negative stain, and then imaged using a transmission electron microscope (TEM) controlled by automated software that enables sampling of a significant portion of the specimen. High-throughput molecular microscopy combines robotic instruments, automated data collection and processing software, and a relational database into a pipeline to prepare, image, and analyze samples in a reproducible manner and with throughputs capable of addressing biopharmaceutical characterization needs in a statistically significant manner. For well-ordered samples such as viruses, and virus-antibody complexes, the achievable resolution can be <0.4 nm.

[0003] In preparing EM grids for molecular microscopy, preparation of the sample grid is often the least controlled step in the process. Typically, a few microliters of sample are applied to a specimen grid. Excess sample is removed by contact blotting with a piece of absorbent paper to thin the film of solution. Finally, vitrification, achieved by plunging the thin sample into a liquid coolant (typically liquid ethane). The ultimate thickness of the sample is related to, among other things, the relative hydrophilicity of the grid surface, the relative humidity and temperature of the environment, and the length of blotting time. In addition, once the solution is applied to the grid it has an extremely high surface to volume ratio and its behavior is dominated by the heat and mass transfer that result from evaporation of the aqueous sample. The result of combining these events is that grid surfaces are not reproducible, either within the same grid or within grids. Portions of the specimen grid will be too thick for effective penetration by the electron beam, while others will be too thin for

proper specimen preservation, while still others will suffer from increases in solute concentrations due to evaporation of water.

[0004] Previously described vitrification robots comprise a guillotine-like grid plunger. The vertical motion is provided by a driven rod to which standard forceps clamping an EM grid are attached. The blotting action is provided by blotting paper attached to rotating disks that are arranged to close on the sample like “clapping hands.” The disks rotate to provide a fresh blotting surface for each clap and the duration and pressure of each action are precisely controlled. The entire apparatus is enclosed in an environmental chamber. A shutter at the bottom of the chamber provides access to the rod to load new forceps/grids and to plunge the sample into the coolant. The operational sequence begins with lowering the rod under stepper motor control and attaching the forceps and grid through the opened shutter. The rod retracts and the shutter closes. The sample solution is loaded onto the grid through a hole in the chamber using a pipette to extract solution from a vial inside the chamber, and deposit a controlled amount (typically 3 μ L) on the grid. The grid is positioned for blotting and a controlled sequence of blotting actions is performed. The grid is allowed to drain/thin for a controlled period. Finally, the rod is disengaged from the stepper motor and pneumatically propelled (approx. 2 m/sec) through the shutter into the coolant. After vitrification, the coolant reservoir engages the rod/forceps/sample assembly and can be removed from the system to permit further manipulation and transfer to the TEM using conventional cryotransfer tools. All aspects of the preparation sequence are controlled by a computer system that includes an easy-to-use operator interface. See, e.g., Iancu et al., Nat. Protocols 1: 2813-2819, 2007.

[0005] Although improving the sample preparation through automating the steps into a more reproducible form, previously described vitrification robots still do not provide the level of sample control necessary for truly reproducible molecular microscopy.

BRIEF SUMMARY OF THE INVENTION

[0006] It is an object of the invention to provide methods and devices for preparing frozen vitrified samples for transmission electron microscopy. By reducing the volume of sample from microliter scale to picoliter scale, the requirement for blotting of excess fluid may be minimized or eliminated. In addition, because picoliter scale volumes will not cover an entire EM sample grid surface under achievable contact angles, each EM sample grid may be processed to provide an array of specimen locations on a single grid, each specimen

location having relatively reproducible characteristics of sample thickness. This will permit more thorough sampling of each EM grid. Finally, starting volumes may be reduced by a factor of over 1000, which can permit an improved analysis of very precious biological samples.

[0007] In a first aspect, the present invention provides a system for preparing an electron microscopy sample on an EM sample grid. The system comprises:

- a. a plunger assembly comprising a shaft operably connected to a shaft drive assembly, a triggering mechanism, and a holder for reversibly receiving an EM sample grid at a first end of the shaft, the shaft drive assembly and triggering mechanism configured to (i) position the EM sample grid at a first position prior to a trigger event, and (ii) displace the shaft in a first direction at a predetermined rate and position the EM sample grid at a second position following a trigger event;
- b. a drop dispenser configured to dispense fluid from one or more dispensing elements onto one or more independently addressable subregions of the EM sample grid in the first position;
- c. a sample reservoir operably linked to the drop dispenser; and
- d. a cryogen reservoir configured to position a cryogenic liquid at the second position.

[0008] In various embodiments, the drop dispenser is configured and arranged to reproducibly dispense volumes smaller than microliter volumes. Preferred drop dispensers dispense in nanoliter volumes, and more preferably picoliter volumes. As used herein, the term “picoliter volumes” refers to a volume of liquid that is at least 1 pL and which is less than 1 nL; “nanoliter volumes” refers to a volume of liquid that is at least 1 nL and which is less than 1 μ L; and “microliter volumes” refers to a volume of liquid that is at least 1 μ L and which is less than 1 mL.

[0009] In alternatives to step b, the drop dispenser may be configured to dispense fluid from one or more dispensing elements onto one or more independently addressable subregions of the EM sample grid between the first position and the second position. This dispensing may occur, for example, in “mid-flight” of the plunger assembly; alternatively, the plunger assembly may be stopped at an intermediate position between the first and second positions.

[0010] In various embodiments, the sample volume(s) are applied to subregions of the EM sample grid surface by spotting such as by the use of robotic micropipetting techniques, or more preferably using “ink jet” printing technologies. Ink jet printing technologies known in the art include devices equipped with pins, or sample ejection elements that dispense using thermal, sonic, or piezoelectric impulses. Among the methods mentioned above, the inkjet method is a preferred sample application method because of its ability to carry out high-density, precise spotting.

[0011] The inkjet method is a method in which a sample solution of interest is placed in an extra-fine nozzle, pressure or heat is instantaneously applied on a portion near the nozzle's tip to correctly eject an extremely low volume of sample from the nozzle's tip and directed to the surface of the EM grid. For example, the inkjet head may be a bubble-jet head having a mechanism for discharging a solvent with the application of thermal energy; a piezo-jet head that ejects a solution using a piezoelectric element; etc. Preferably, the drop dispenser comprises multiple nozzles that can be used to “print” sample volumes onto discretely addressable locations of the EM sample grid. When the sample solution is ejected from the inkjet head, each sample droplet forms a circular spot, the thickness and expansion of which is controlled by the hydrophilicity of the EM grid surface. Connection with an adjacent spot can be effectively prevented even when the spots of sample solution are spotted in high density.

[0012] In certain embodiments, the drop dispenser may be operably connected to a positioning drive configured to provide adjustment of the drop dispenser relative to the EM sample grid in the first position. Preferably, the positioning drive permits mobility in all three axes. Alternatively, the drop dispenser may be held fixed, and the plunger assembly may be operably connected to a positioning drive configured to provide adjustment of the drop dispenser relative to the EM sample grid; or both the drop dispenser and the plunger assembly may be operably connected to positioning drives. Through the use of any of these configurations, the system can flexibly allow for precise location of each dispensing element relative to the grid surface.

[0013] As noted above, once the sample solution is applied to the grid it has an extremely high surface to volume ratio and its behavior is dominated by the heat and mass transfer that result from evaporation of the aqueous sample. In order to more rapidly reach an optimal equilibrium between evaporation and condensation at the EM grid surface, an environmental chamber configured to provide controlled relative humidity and temperature may be

provided. At its simplest, a transparent box may be placed over the entire apparatus and the interior maintained at a predetermined temperature and humidity. Other configurations will be apparent to one of skill in the art.

[0014] In certain embodiments, the system may further comprise one or more of: a first camera system configured to provide monitoring of fluid dispensed from the one or more dispensing elements, and a second camera system configured to provide monitoring alignment of the position of the dispensing elements relative to the EM sample grid in the first position. In certain embodiments this second camera is also used to monitor droplet profiles on the EM sample grid surface.

[0015] The plunger shaft may be driven between an “up” (sample application) position and a “down” (sample vitrification) position using a variety of conventional drive mechanisms, such as pneumatic, hydraulic, and electric motor actuators. Alternatively, the drive mechanism may be omitted and the plunger shaft driven downward by gravity. The triggering mechanism is any switch that causes the plunger shaft to move from an up to a down position, and a “triggering event” is an event that initiates this movement. In certain embodiments, the triggering mechanism can act as a toggle, moving the plunger shaft in both directions.

[0016] In related aspects, the present invention relates to methods for preparing an electron microscopy sample on an EM sample grid using the system described herein. These methods generally comprise:

- a. positioning the EM sample grid on a plunger assembly, the plunger assembly comprising a shaft operably connected to a shaft drive assembly, a triggering mechanism, and a holder for reversibly receiving the EM sample grid at a first end of the shaft, the shaft drive assembly and triggering mechanism configured to (i) position the EM sample grid at a first position prior to a trigger event, and (ii) displace the shaft in a first direction at a predetermined rate and position the EM sample grid at a second position following a trigger event;
- b. with the EM sample grid in the first position or between the first and second positions, dispensing one or more sample volumes onto one or more independently addressable subregions of the EM sample grid using a drop dispenser configured to dispense fluid from one or more dispensing elements;

c. activating the triggering mechanism to displace the shaft to the second position, wherein the EM sample grid is immersed into a cryogenic liquid contained within a cryogen reservoir.

[0017] The methods of the present invention may be used to prepare frozen vitrified biological samples for detailed analysis by transmission electron microscopy. Suitable biological samples can comprise proteins, viruses, virus-like particles, organelles, liposomes, etc. In view of the interest of regulatory agencies in obtaining information on the aggregation of such therapeutic proteins, preferred specimens are proteins of pharmaceutical interest, such as therapeutic antibodies.

DETAILED DESCRIPTION OF THE INVENTION

[0018] Over thirty years ago, Dubochet and colleagues first demonstrated that biological specimens in their native hydrated state could be embedded in vitrified buffer and imaged in the transmission electron microscope (TEM) without loss of structural preservation. This paved the way for the development of cryo-TEM as a field, and the technique has been used to study a vast array of structures over the past 3 decades. Specimens for cryo-EM are normally prepared by embedding them in a thin layer of vitrified ice suspended over an EM grid substrate that may be either continuous or fenestrated. Ideally the vitrified layer should be just slightly thicker than the diameter of the particle (50-500nm), providing a well distributed and well separated single layer of particles in random orientations.

[0019] Current methods of preparing the vitrified sample typically start with applying a relatively large volume (~3 μ l) of sample to the surface of an EM grid, then reducing the sample to a thin layer by applying filter paper to one or both sides of the grid to blot away most of the volume, followed by quick plunging into liquid ethane. Fig. 1A. A variety of devices have been developed to try to optimize this method, including both home-made guillotine plungers and more automated commercial devices. All of these devices, however, rely on using macroscopically large filter paper surfaces to try to produce a layer of liquid some 100's of nm thick. These methods allow very limited control of the sample layer on the substrate surface and, not surprisingly, the outcome of these methods is not optimal, normally resulting in large areas of the grid surface area that have vitrified ice that is either too thick or too thin and particles are also sometimes distributed unevenly as a result of varying ice thickness. In addition to the traditional method of specimen pipetting and blotting, variant methods have been described that involve creating a dense spray of specimen (1-20 μ m

droplets) using nebulizers, micro-nozzles and electrospray mechanisms, where the grid is plunged through the sprayed region on its way to vitrification. Droplets landing on the grid surface do not need further blotting and spread out on contact due to surface hydrophilicity. However, there is little control over individual droplet sizes and the timing of when those droplets impact the grid surface. Moreover, the liquid-handling devices used for these processes often entail large dead-volumes and thus specimen wastage, probably a primary reason why this particular method has not seen more mainstream usage.

[0020] The quality and thickness of the vitrified layer will depend on a number of factors including the properties of the specimen itself (e.g. viscosity, particle concentration), the nature of the substrate surface (e.g. hydrophobicity, flatness), the blotting paper (e.g. angle of contact, surface roughness, absorbency, blot time), and the plunging parameters (e.g. dwell time after blotting, speed of plunge, temperature of the cryogen). Thus, even highly skilled technicians may need to spend considerable effort optimizing this process for a new specimen; precious specimen is consumed by each trial, and time is required both in the laboratory and on the microscope to evaluate the prepared grids.

[0021] The present invention describes new technology for preparing thin films of vitrified sample using picoliter or nanoliter dispensing methodologies to dispense onto subregions of EM grids, depicted in Fig. 1B. This approach avoids the use of blotting paper and provides a very flat, highly controlled surface, thus considerably reducing many of the adverse factors that contribute to highly variable results with the current methods. The dispense system comprises of a dispense head that may be piezo-electric based, thermal or other inkjet technology related. The invention also describes a method to precisely control the time of sample dispense and EM grid plunge into liquid ethane, which is a critical component of the technology - to vitrify the sample before evaporation and drying can take place. Non-contact printing can be achieved using piezoelectric "inkjet" printing, a technology developed over the last 30 years. The technique involves utilizing a piezoelectric element to impulsively impart an acoustic pressure wave to liquid in the tip of a fine nozzle, causing a droplet of the liquid to be ejected from the tip. Fig. 1C. The voltage applied and the size of the nozzle determines the droplet volume, which can be precisely controlled to 10's of pL. Additionally, and of particular interest to cryo-TEM, is that piezo-electric based dispensing is compatible with a wide range of biological specimens such as nucleic acids, proteins, bacteria, mammalian cells, nanoparticles, micron-sized beads, polymers and aggregates.

[0022] The non-contact nature of the preferred dispensing system also provides complete independence from the substrate properties, opening up the possibility to tune surface properties and incorporate nano-structural features that can be precisely targeted. Droplet generation can be monitored in real-time and can be used as triggers for downstream instrumentation. Alternatively, the droplet generation itself can be triggered by upstream instrumentation, at time-scales of a few μ secs. The ability to position multiple dispense heads can allow for simultaneous multiple sample application onto a single substrate within a hundred micron separation. Inkjet dispensers can aspirate specimen volumes as low as 100 nL, dispense a precise volume (in discrete multiples of the droplet volume – 10's of pL, and importantly retrieve any specimen remaining in the head. This feature is of particular interest when specimen availability is low (a situation for most eukaryotic complexes and membrane proteins). Moreover, inkjet print-heads are available commercially and are robust given the technological maturity of the microarray market. Given these technical and logistical advantages, we have initiated the integration of piezoelectric inkjet technology as a specimen application step in cryo-TEM to increase the efficiency of obtaining thin vitrified particles.

[0023] Important time-points starting from droplet launch out of the dispense head to the desired time of vitrification are indicated in Figure 2. T-fire (zero) is the time the droplet leaves the dispense head. T-impact (on the order of a few msec) is the time the droplet impacts the surface of the substrate, and T-pinned (order of tens of msec) is the time to reach maximum contact diameter. Thereafter, the droplet is 'pinned' to the surface and is in evaporation phase. Tplunge (order of hundreds of msec) is the time-point when the plunge trigger is generated and the sample reaches the liquid ethane at T-vitrify (order of hundreds of msec). T-vitrify depends on the distance of the grid from the liquid ethane reservoir, the plunging mechanism (gravity, pneumatic or electronic drives), and plunge velocity. The vitrification phenomenon occurs within the microsecond time-scale and is much faster relative to the other time periods mentioned here. The invention provides systems and methods that can more precisely control the (picoliter and nanoliter) dispense parameters (including volume, dispense velocity, head-grid separation) and the plunge mechanism. Light-weight high-speed motors and encoders (with speeds of several meters / second) are utilized to further enhance the positioning precision and speed of the plunging process.

[0024] A basic schematic of the invention comprising of the dispense and vitrification system (dispense heads using inkjet technologies - thermal, bubble or piezoelectric) and other major components is shown in Figure 3. An environmental chamber (not shown in figure)

houses the entire setup to provide the desired ambient conditions of relative humidity and temperature. The plunge mechanism (p) comprises a motor drive, precisely controlled by a micron-precision linear encoder. The plunge assembly comprises the stem and a grid holder (t). While depicted in the figure as a pair of fine point tweezers, the grid holder is preferably precisely machined with clips to house the EM grid (g) and orient the confined areas horizontal and perpendicular to the system axis. This can act to prevent angular offset during droplet targeting.

[0025] An optional front looking camera (r) with optics (o) permitting a magnified view of the EM grid faces the plunge assembly and allows for confirming alignment of the droplets in relation to the mounted grid. Dispense heads (h), in this case piezo-electric heads designed for picoliter volumes, are stacked and the assembly mounted on an X-Y-Z stage (v) for positioning in relation to the plunge assembly. Each dispense head houses a linear direction set-screw, allowing for individual tuning of its position in relation to the stack (up to 2 mm). This ensures that each dispense head can access all locations of an EM grid, independent of the overall positioning of the stack assembly.

[0026] A side view camera (s) allows for head initialization and droplet monitoring using a LED strobe delay (u). This assembly is mounted on an X-Y-Z stage to ensure image focus in relation to all piezo-dispense heads. A removable sample reservoir (shown below w) is positioned vertically behind the plunge assembly and in direct path of the stack assembly. An electronic shutter controls the opening of the environment chamber for the plunge assembly to access the liquid ethane reservoir (q) at the final stage of the grids downwards trajectory. Both X-Y-Z stages can be either manually controlled or integrated with automatic drives. All electronics are controlled by a single computer interface and control code integrated in software and firmware.

[0027] Two schemes for multiple-sample dispensing onto single EM grids are shown by which the invention achieves precision sub microliter dispense and spatial targeting. In the first scheme (Fig. 4A), the dispense head stack assembly is aligned and positioned with the grid. Individual dispense heads are staggered in space to target one of the three columns of a 3x3 array. During the dispense phase, the stack assembly position is maintained static, while the grid is driven downwards by the motor. Positional information provided by the precision linear encoder and dimension information of the design provides the exact trigger sequence of individual piezo-dispense heads. The trigger sequence of nine piezo-dispense heads depends on the velocity of the plunge assembly, the dimensions of the array layout on the

grid and the inter-piezo-head spacing. In the second scheme (Fig. 4B), the piezo-head stack assembly is positioned vertically and its position driven perpendicular to the direction of the plunge assembly. In this scenario there is no need to spatially align individual piezo-dispense heads, but requires the use of automated position control during the dispense phase. Trigger sequence can be accurately timed by controlling both the grid and piezo-stack assembly position.

[0028] Fig. 5 depicts an exemplary embodiment of the system of the invention in schematic form. The system includes four major components: a piezo-dispense system, a high-speed fluorescence microscopy viewing system, an environmental control chamber and an in-flight droplet imager. The piezo-dispense comprises a drive electronics sub-system, one or more dispense heads with 24 μ m diameter orifices, and the side camera visualization system that includes a CMOS USB camera, 5x lens and a controlled strobe light LED. The dispense head is capable of generating picoliter droplets of volume controlled by the drive electronics. The strobe and side visualization system is capable of high-speed in-flight imaging of the fired droplets. The fluorescence system comprises a 20x objective lens, excitation/emission compatible optics with 488/520nm filters will be custom configured to acquire 100Hz frame rates using a CCD camera (DVC-340, DVC Inc.) that supports data transfer over a Gigabit Ethernet (GigE) interface. The environment chamber is custom designed with inlet and outlet ports controlled by a gas/vapor controlling unit (comprised of a humidifier and relative humidity sensors).

[0029] The top face of the chamber will include an access port with a mechanical shutter to position the piezo-dispense head over the EM grid. The chamber is positioned on a cooling stage (Bioscience tools, BTC-S) with a temperature controller (BTC-1-100) providing for a range of 0-100°C at 0.1°C resolution. The environment chamber / cooling stage assembly is positioned on an X-Y stage for positioning the EM grid relative to the objective lens. All control signals and acquisition data are synchronized in software.

[0030] A typical process flow will be comprised of: (1) place EM grid in chamber assembly and focus fluorescence scope; (2) stabilize chamber ambient conditions (temperature, humidity); (3) load the sample into the piezo-dispense head outside the chamber; (4) confirm in-flight droplet creation and integrity with top-port shutter closed; (5) open top port shutter and position piezo-dispense head at grid target area; (6) dispense picoliter volume onto the grid; (7) acquire fluorescent images at 100 Hz. Given that the grid area is 2mm diameter and the spotting spread area (for picoliter volumes) is expected to be

within 500 microns, multiple dispenses can be conducted on the same grid at different ambient and sample conditions by repeating the process.

[0031] Examples:

[0032] Example 1:

[0033] To test if picoliter to nanoliter dispensing of specimen using piezo-electric inkjet technology can be utilized for cryo-TEM, a system that integrated several modules as shown in Fig. 3. A commercially available piezo-electric dispense head was incorporated with central bore size 24 μm . This head was capable of dispensing discrete specimen droplets of 32 pL; observed in-flight using a stroboscopic LED light and side-view lens / camera system that allowed for viewing dispensed droplets at precise time-points (0-100 μsecs) after droplet generation from the head. Specimen dispense was triggered by software via the accompanying piezo-electric head control module and the number of droplets, frequency and droplet velocity could be modified as desired. Rear-view imaging of the grid at an acquisition rate of 100 Hz allowed for visualizing droplet impact, spreading and evaporation dynamics. The rear-view camera was also used to align the grid with the dispense head and provided a way to visualize different dispense conditions on the same grid (prior to vitrification). The grid and dispense head were independently manipulated for alignment using two 3-axis manual positioners, which allowed for precise targeting of specimen droplets on the grid. In order to retract the dispense head away immediately after dispense sequence was completed, the dispense head was mounted on a miniature pneumatic stage whose binary position (in or out) was controlled by a hand-operated pneumatic valve. A 90° rotation stage was incorporated to rotate the dispense head between the vertical (specimen aspiration) and horizontal (specimen dispense) positions, which also provided a way to retrieve remaining specimens in the dispense head. The vertical position allowed for specimens to be aspirated directly from vials and well-plates.

[0034] Example 2.

[0035] Using the traditional sample pipetting and blotting technique the entire grid is affected, limiting only one specimen to be evaluated per grid during cryo-TEM study. The ability to precisely align and confine droplets on the substrate could open up the possibility to delivery multiple samples per grid , increasing the throughput of experimentation. Inkjet technology allows for precise positioning of dispense heads in relation to grid substrates, which provides a way to spatially control specimen dispensing on a single EM grid. Spatial

targeting was confirmed by fluorescence imaging of the specimens (ex/em: 488/520 dye) on the grid. Droplet impact and spreading was further studied in hydrophobic and hydrophilic conditions. For untreated carbon grids the contact angle observed was $\sim 90^\circ$, upon droplet dispensing (25 droplets) and image capture. In contrast, when the carbon grids were treated in an Oxygen / Argon plasma discharge, the contact angles reduced considerably to $\sim 15^\circ$. This effect of surface wettability change was evaluated for small volume (64 pL, 2 droplets) targeted dispensing of fluorescent specimens on holey carbon grids by fluorescence and phase imaging. On hydrophobic grids the droplet spreading was non-uniform within the targeted squares, leading to aggregated areas. However, for hydrophilic grids the droplets spread out uniformly within the targeted squares and no aggregates were observed in both fluorescence and phase images.

[0036] Example 3.

[0037] As one of the goals of this new methodology is to eliminate manual blotting, it is important that the samples on the grid be vitrified at time-points when the sample thickness is suitable for cryo-TEM imaging. This can be accomplished by viewing the droplet dynamics (spreading and drying) on the grid in real-time and triggering the plunge process (for vitrification) at an optimal time-point post-dispensing. At the experimental environment conditions (RH 10%, Temperature 25°C), a single droplet dries (as observable by rear-view imaging) within 300 msec upon impact onto the grid. Under these conditions, higher number of droplets led to longer drying times (and also larger spreading distances on the grid; data not shown). Also, the repeatability of the droplet dynamics (based on drying times) is high for the droplets dispensed on the grid, allowing for automated plunging events to be accurately timed. In the current system, the plunging event is triggered manually by a hand-operated pneumatic valve, under visual feedback from the real-time camera. Operator reaction times were not accurate within the 100 msec - 1 sec range. Therefore, for the purpose of experimentation, larger droplet numbers (>50), giving longer times to assess droplet spreading and drying effects, were used to vitrify samples.

[0038] Example 4.

[0039] Inkjet dispensing has been successfully used in developing protein and antibody arrays for a variety of applications. Given the functional preservation of protein and antibodies after dispensing in these applications, it can be assumed that the dispensing method itself does not greatly compromise the stability of the biological macromolecules.

However, in all the previous applications, the assay readouts (mostly fluorescence or colorimetric) were not molecular imaging based, and therefore it could not be concluded with certainty what population of dispensed macromolecules were structurally preserved. For application of inkjet technology to TEM imaging, it is imperative that the dispensing technology itself does not degrade the macromolecules or their complexes; else imaging results will lead to artifacts and broken particles. Therefore, to evaluate the effect of the piezo-electric inkjet heads on particle structure stability, several macromolecules with known structures (GroEL, Microtubules, Lipid Nanotubes, Cucumber Necrosis Virus) were dispensed (32nL, 1000 droplets) onto carbon-film grids and then subsequently negative stained manually with 2% Uranyl Acetate (performed within 10 secs of dispensing). Particles in all four cases were structurally intact (comparable to their previously known structures) with no evidence of any instability. To further assess the compatibility of piezo-electric inkjet dispensing for maintaining functional activity of eukaryotic complexes, human Dicer/TRBP complex was dispensed via the piezo-electric inkjet head into a test aliquot and its ability to dice double stranded RNA compared to control aliquots. Results indicated that the inkjet dispensing did not affect the dicing activity of the Dicer/TRBP complex as assessed by an RNA gel.

[0040] The next step was to confirm the ability of the integrated inkjet dispensing, plunging and vitrification system to obtain samples suitable for cryo-TEM imaging. For this purpose, 1.6 nL (50 droplets) of Tobacco Mosaic Virus (TMV) and 3.2 nL (100 droplets) of a molecular chaperone (GroEL), were dispensed onto continuous carbon and holey carbon grids, respectively, and vitrified at time-points prior to complete drying. All experimental conditions were at RH 10% and temperature 25°C, with the plunge process triggered under manual operator control (using real-time visual feedback from the rear-view camera). The continuous carbon grids provided a non-porous surface for droplet spreading, which allowed for uniform spreading in a radial manner. Also, after the spreading was complete (within 200 msec) and the droplet was pinned, drying patterns could be observed within 2 secs. On visual onset of the drying patterns, the grids were plunged for vitrification and imaged using cryo-TEM.

[0041] At low magnification, typical spot profiles were circular with dark (thicker) center areas and lighter (thinner) areas toward the perimeter. Specimen vitrification was thin enough to visualize TMV particles at high-magnification in the peripheral areas. In the case of holey carbon grids (porous due to the 2 µm holes), the spreading profile was more complex. Instead

of uniform circular spreading, the dispensed volume traversed through the 2 μm holes in the carbon membrane to both sides of the grid, contacting the support copper mesh, which induced local droplet dynamics within the squares. Sample spreading over the grid is complete within 300 msec and the manual plunge triggered at 4 secs, when the sample was observed receding due to evaporation. Low-magnification cryo-TEM images indicated individual squares displaying local droplet drying dynamics. Squares on the grid could be identified where vitrified sample was thin enough for visualizing GroEL over the holes at high-magnification. For TMV particles, the 23 \AA diffraction patterns were identifiable, and for GroEL, two-dimensional class averages of picked particles indicated seven-fold symmetry - both results suggesting preservation of particle structure.

[0042] While the invention has been described and exemplified in sufficient detail for those skilled in this art to make and use it, various alternatives, modifications, and improvements should be apparent without departing from the spirit and scope of the invention. The examples provided herein are representative of preferred embodiments, are exemplary, and are not intended as limitations on the scope of the invention. Modifications therein and other uses will occur to those skilled in the art. These modifications are encompassed within the spirit of the invention and are defined by the scope of the claims.

[0043] It will be readily apparent to a person skilled in the art that varying substitutions and modifications may be made to the invention disclosed herein without departing from the scope and spirit of the invention.

[0044] All patents and publications mentioned in the specification are indicative of the levels of those of ordinary skill in the art to which the invention pertains. All patents and publications are herein incorporated by reference to the same extent as if each individual publication was specifically and individually indicated to be incorporated by reference.

[0045] The invention illustratively described herein suitably may be practiced in the absence of any element or elements, limitation or limitations that is not specifically disclosed herein. Thus, for example, in each instance herein any of the terms "comprising," "consisting essentially of" and "consisting of" may be replaced with either of the other two terms. The terms and expressions that have been employed are used as terms of description and not of limitation, and there is no intention that in the use of such terms and expressions of excluding any equivalents of the features shown and described or portions thereof, but it is recognized that various modifications are possible within the scope of the invention claimed. Thus, it

should be understood that although the present invention has been specifically disclosed by preferred embodiments and optional features, modification and variation of the concepts herein disclosed may be resorted to by those skilled in the art, and that such modifications and variations are considered to be within the scope of this invention as defined by the appended claims.

[0046] Other embodiments are set forth within the following claims.

We claim:

1. A system for preparing an electron microscopy sample on an EM sample grid, comprising:
 - a. a plunger assembly comprising a shaft operably connected to a shaft drive assembly, a triggering mechanism, and a holder for reversibly receiving an EM sample grid at a first end of the shaft, the shaft drive assembly and triggering mechanism configured to (i) position the EM sample grid at a first position prior to a trigger event, and (ii) displace the shaft in a first direction at a predetermined rate and position the EM sample grid at a second position following a trigger event;
 - b. a fluid dispenser configured to dispense fluid from one or more dispensing elements onto one or more independently addressable subregions of the EM sample grid in the first position or between the first and second positions;
 - c. a sample reservoir operably linked to the drop dispenser; and
 - d. a cryogen reservoir configured to position a cryogenic liquid at the second position.
2. A system according to claim 1, wherein the one or more dispensing elements dispense a picoliter sample volume by thermal inkjet printing, acoustic inkjet printing, or piezoelectric inkjet printing onto the one or more independently addressable subregions of the EM sample grid.
3. A system according to claim 1, wherein the one or more dispensing elements comprise one or more print pins that dispense a picoliter sample volume by physical contact with one or more subregions of the EM sample grid.
4. A system according to claim 1, wherein the drop dispenser is operably connected to a positioning drive configured to provide adjustment of the drop dispenser relative to the EM sample grid in the first position or between the first and second positions.
5. A system according to claim 1, wherein the drop dispenser comprises a plurality of dispensing elements configured to dispense a picoliter sample volume onto different independently addressable subregions of the EM sample grid.

6. A system according to claim 1, further comprising an environmental chamber configured to provide controlled relative humidity and temperature.
7. A system according to claim 1, further comprising one or more of: a first camera system configured to provide monitoring of fluid dispensed from the one or more dispensing elements, and a second camera system configured to provide monitoring alignment of the position of the dispensing elements relative to the EM sample grid in the first position and/or monitoring of droplet characteristics on the EM sample grid.
8. A system according to claim 1, wherein the shaft drive assembly comprises a pneumatic drive.
9. A system according to claim 1, wherein the shaft drive assembly comprises a stepper motor drive.
10. A system according to claim 1, comprising a computer interface configured to control operation of one or more system elements.
11. A method for preparing an electron microscopy sample on an EM sample grid, comprising:
 - a. positioning the EM sample grid on a plunger assembly, the plunger assembly comprising a shaft operably connected to a shaft drive assembly, a triggering mechanism, and a holder for reversibly receiving the EM sample grid at a first end of the shaft, the shaft drive assembly and triggering mechanism configured to (i) position the EM sample grid at a first position prior to a trigger event, and (ii) displace the shaft in a first direction at a predetermined rate and position the EM sample grid at a second position following a trigger event;
 - b. with the EM sample grid in the first position or between the first and second positions, dispensing one or more sample volumes onto one or more independently addressable subregions of the EM sample grid using a fluid dispenser configured to dispense fluid from one or more dispensing elements;
 - c. activating the triggering mechanism to displace the shaft to the second position, wherein the EM sample grid is immersed into a cryogenic liquid contained within a cryogen reservoir.

12. A method according to claim 11, wherein the one or more dispensing elements dispense a picoliter sample volume by thermal inkjet printing, acoustic inkjet printing, or piezoelectric inkjet printing onto the one or more independently addressable subregions of the EM sample grid.
13. A method according to claim 11, wherein the one or more dispensing elements comprise one or more print pins that dispense a picoliter sample volume by physical contact with one or more subregions of the EM sample grid.
14. A method according to claim 11, wherein the drop dispenser is operably connected to a positioning drive configured to provide adjustment of the drop dispenser relative to the EM sample grid.
15. A method according to claim 11, wherein the drop dispenser comprises a plurality of dispensing elements that dispense a picoliter sample volume onto different independently addressable subregions of the EM sample grid.
16. A method according to claim 11, further comprising maintaining the EM sample grid in a controlled relative humidity and temperature environment during at least step (b).
17. A method according to claim 11, further comprising one or more of: monitoring of fluid dispensed from the one or more dispensing elements using a first camera system, and monitoring alignment of the position of the dispensing elements relative to the EM sample grid and/or monitoring of droplet characteristics on the EM sample grid in the first position using a second camera system.
18. A method according to claim 11, wherein the shaft drive assembly comprises a pneumatic drive.
19. A method according to claim 11, wherein the shaft drive assembly comprises a stepper motor drive.

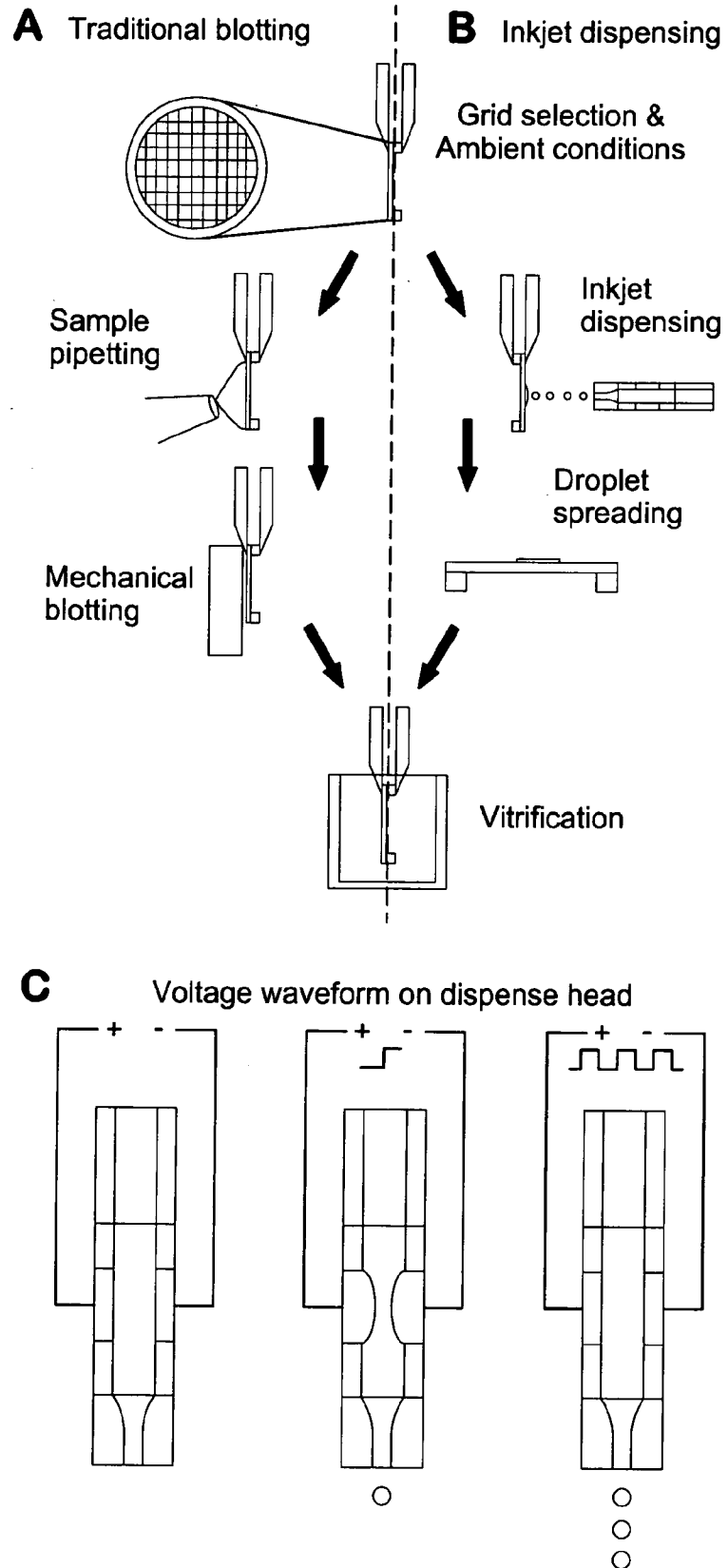

FIG. 1

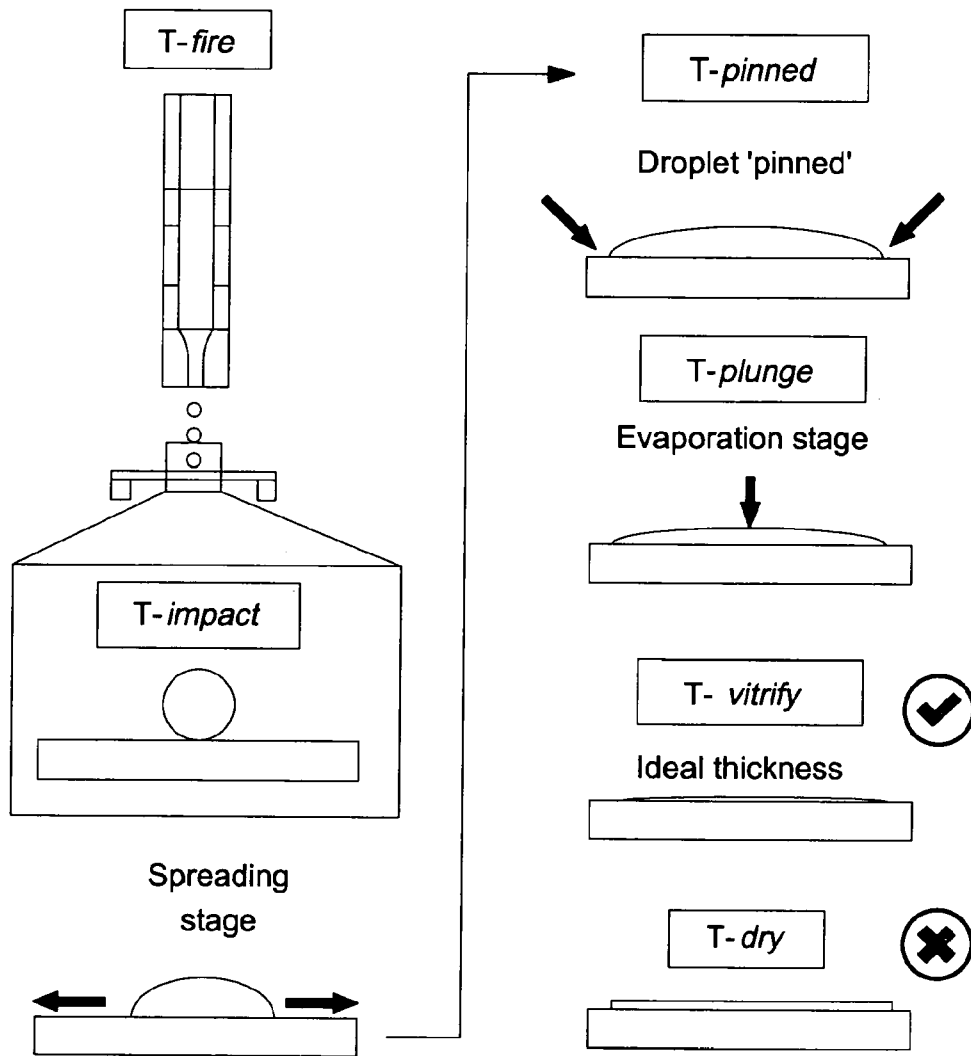

FIG. 2

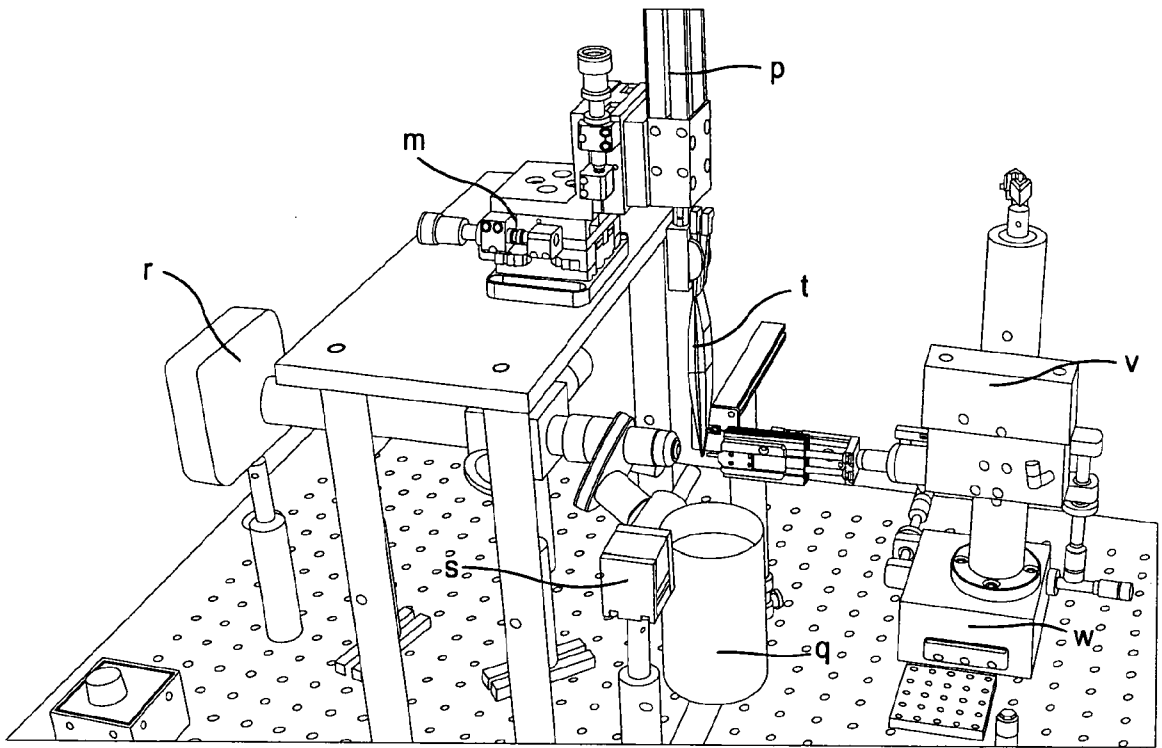

FIG. 3A

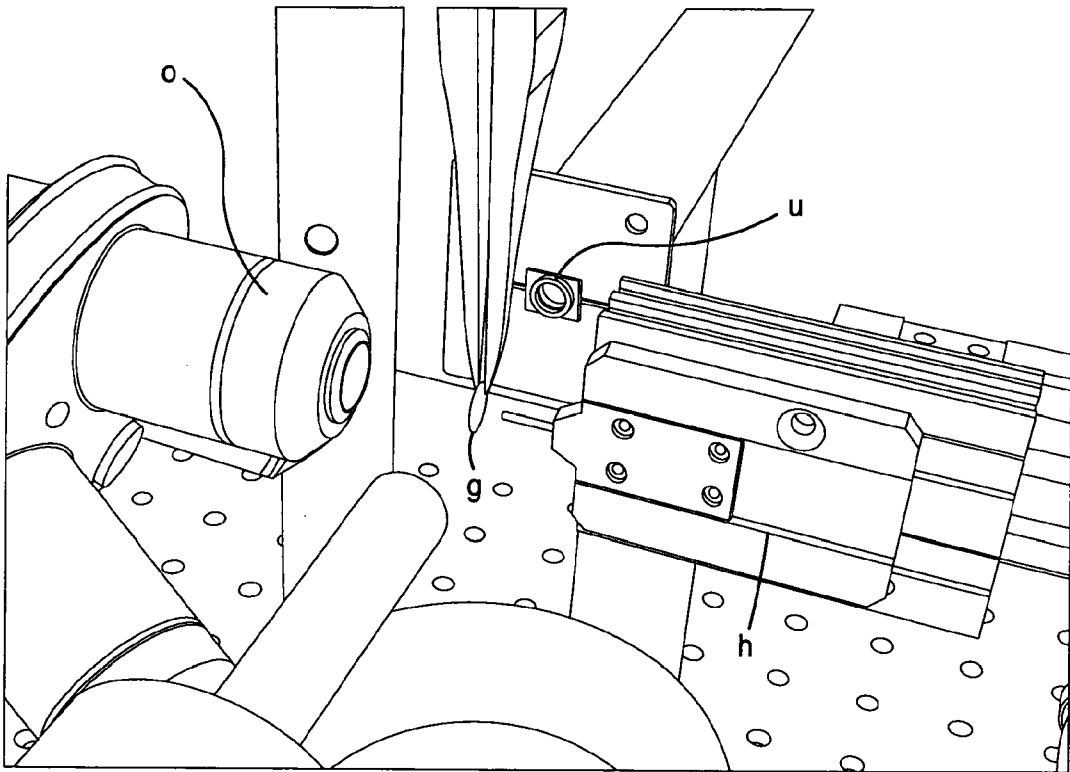
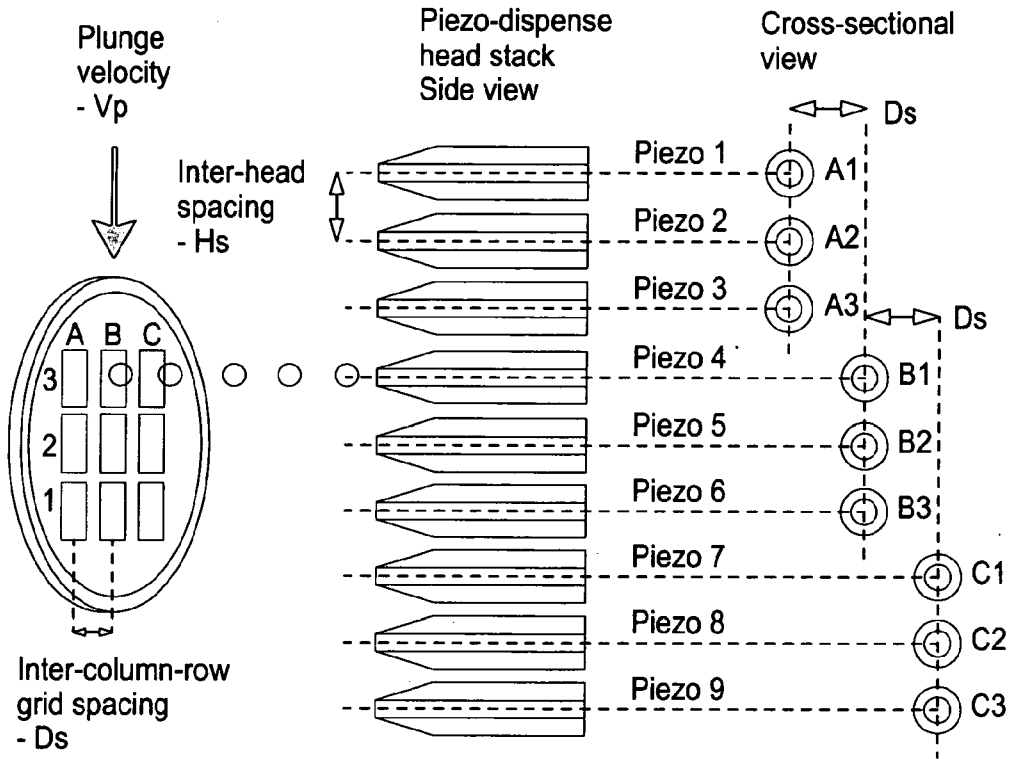

FIG. 3B



Timing diagram of dispense trigger sequence

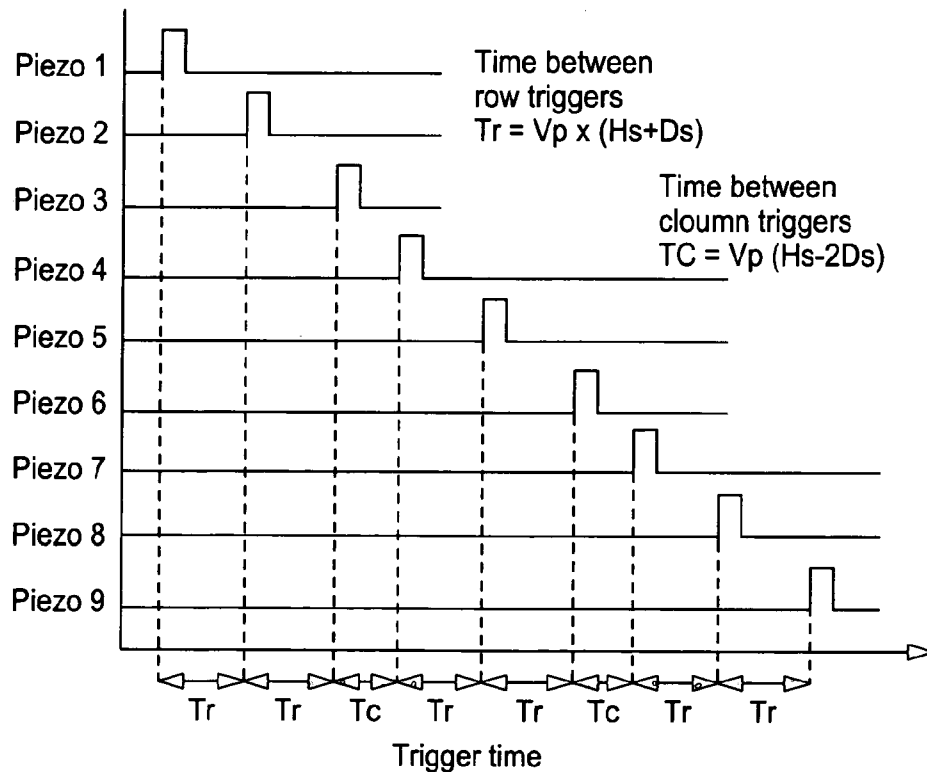

FIG. 4A

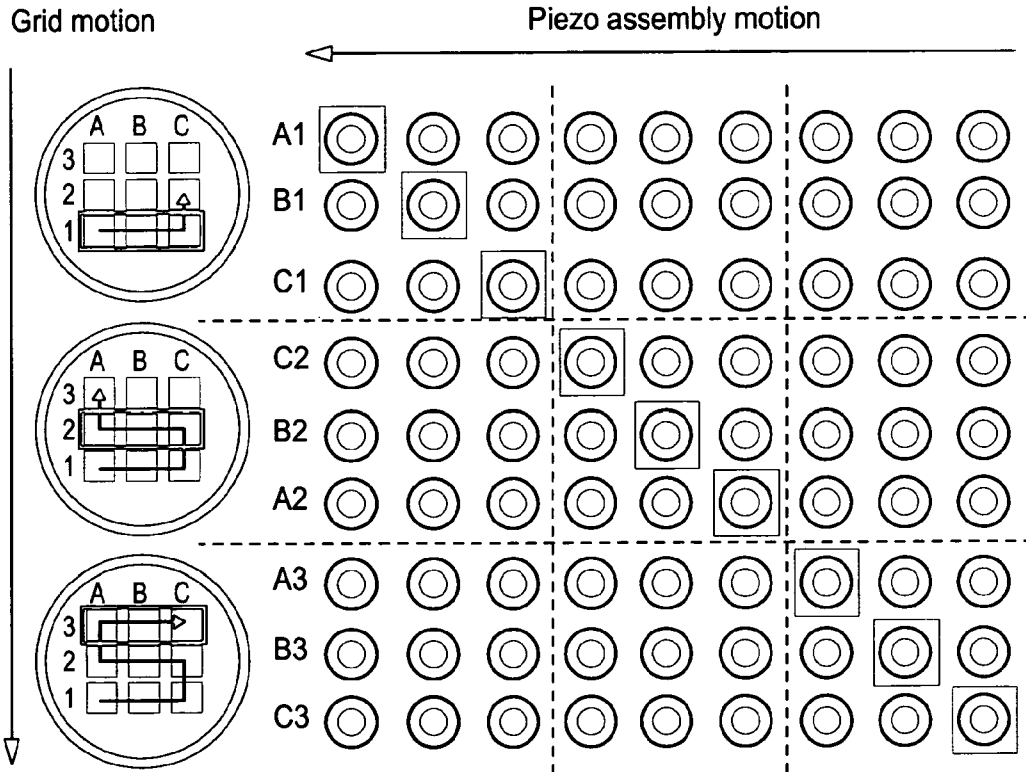
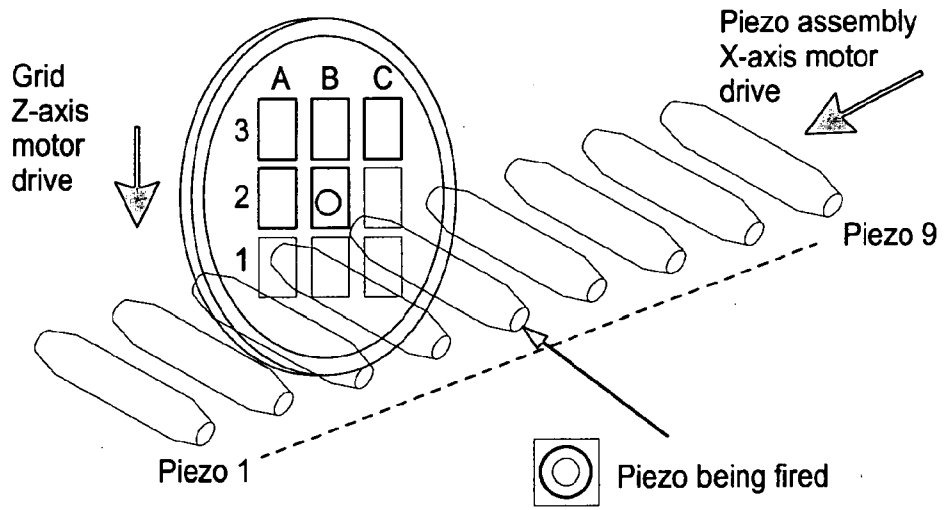

FIG. 4B

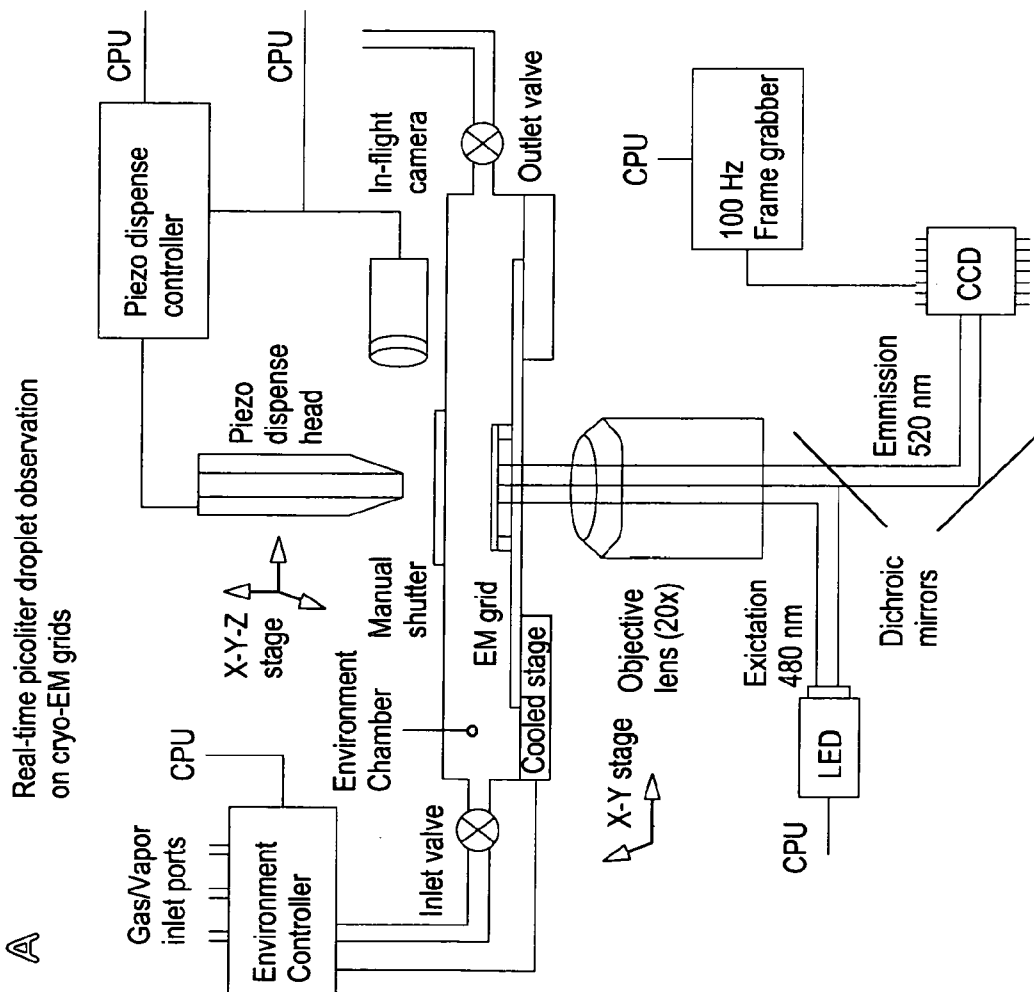
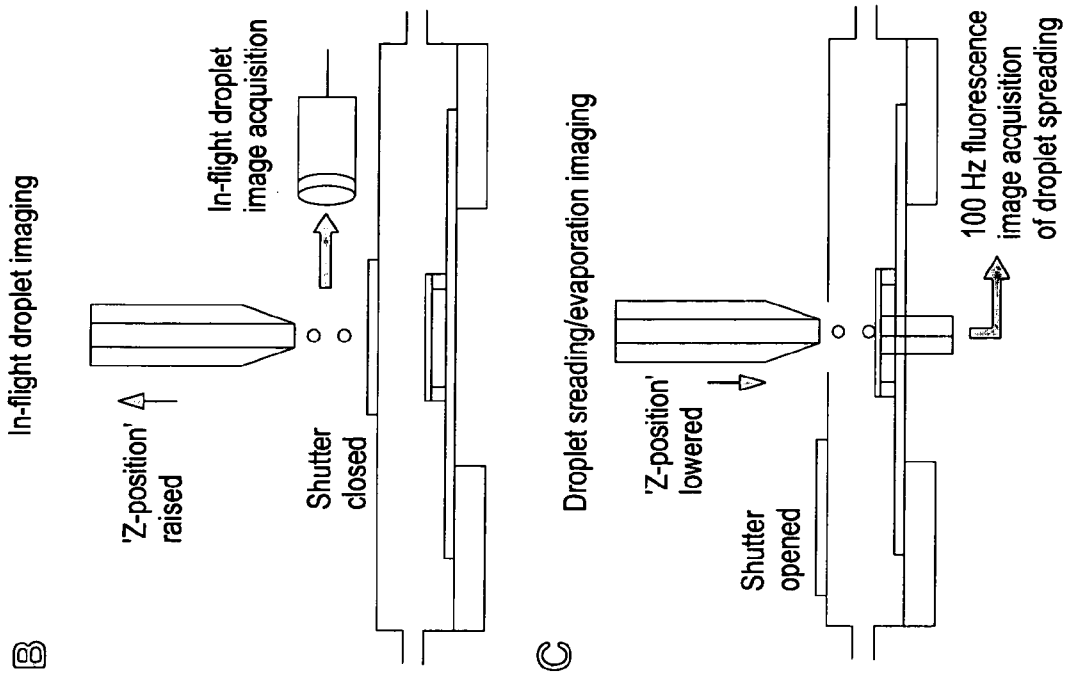

FIG. 5

INTERNATIONAL SEARCH REPORT

International application No.
PCT/US2013/000019**A. CLASSIFICATION OF SUBJECT MATTER****G01N 1/28(2006.01)i, H01J 37/26(2006.01)i**

According to International Patent Classification (IPC) or to both national classification and IPC

B. FIELDS SEARCHED

Minimum documentation searched (classification system followed by classification symbols)

G01N 1/28; G01N 1/30; B32B 3/00; B81B 7/00; G01N 1/31; G01N 33/53; G01D 15/16; C40B 40/00; C12Q 1/68; H01J 37/26

Documentation searched other than minimum documentation to the extent that such documents are included in the fields searched

Korean utility models and applications for utility models
Japanese utility models and applications for utility models

Electronic data base consulted during the international search (name of data base and, where practicable, search terms used)

eKOMPASS(KIPO internal) & Keywords: electron, microscopy, cryogen, dispenser and picoliter

C. DOCUMENTS CONSIDERED TO BE RELEVANT

Category*	Citation of document, with indication, where appropriate, of the relevant passages	Relevant to claim No.
X	US 2010-0068757 A1 (ANGROS, LEE H.) 18 March 2010	1, 11
Y	See paragraphs 3,101-110,167,200-220 and figures 24-31.	2-6,8-10,12-16 ,18-19
A		7, 17
Y	US 6794052 B2 (SCHULTZ et al.) 21 September 2004 See columns 3-4,12,22-24,30-31 and figures 1-13.	2,4-5,9-10,12 ,14-15,19
Y	US 2003-0143612 A1 (AULT-RICHE et al.) 31 July 2003 See paragraphs 196-201 and figures 1-5.	3, 13
Y	US 2005-0035983 A1 (CRUCHON-DUPEYRAT et al.) 17 February 2005 See paragraphs 258-264 and figures 2,9.	6, 16
Y	US 2010-0160181 A1 (SLIWA, JR. et al.) 24 June 2010 See paragraphs 80-85 and figures 20-21.	8, 18

 Further documents are listed in the continuation of Box C. See patent family annex.

* Special categories of cited documents:

"A" document defining the general state of the art which is not considered to be of particular relevance

"E" earlier application or patent but published on or after the international filing date

"L" document which may throw doubts on priority claim(s) or which is cited to establish the publication date of citation or other special reason (as specified)

"O" document referring to an oral disclosure, use, exhibition or other means

"P" document published prior to the international filing date but later than the priority date claimed

"T" later document published after the international filing date or priority date and not in conflict with the application but cited to understand the principle or theory underlying the invention

"X" document of particular relevance; the claimed invention cannot be considered novel or cannot be considered to involve an inventive step when the document is taken alone

"Y" document of particular relevance; the claimed invention cannot be considered to involve an inventive step when the document is combined with one or more other such documents, such combination being obvious to a person skilled in the art

"&" document member of the same patent family

Date of the actual completion of the international search

14 May 2013 (14.05.2013)

Date of mailing of the international search report

15 May 2013 (15.05.2013)

Name and mailing address of the ISA/KR

Korean Intellectual Property Office
189 Cheongsu-ro, Seo-gu, Daejeon Metropolitan
City, 302-701, Republic of Korea

Facsimile No. 82-42-472-7140

Authorized officer

AHN, Jae Yul

Telephone No. 82-42-481-8525



INTERNATIONAL SEARCH REPORT

Information on patent family members

International application No.

PCT/US2013/000019

Patent document cited in search report	Publication date	Patent family member(s)	Publication date
US 2010-0068757 A1	18.03.2010	AU 2000-60795 A1	30.01.2001
		AU 2006-249956 A1	30.11.2006
		AU 2009-285551 A1	04.03.2010
		CA 2379410 A1	18.01.2001
		CA 2609453 A1	30.11.2006
		CA 2772493 A1	04.03.2010
		CN 101228429 A	23.07.2008
		EP 1208378 A1	29.05.2002
		EP 1208378 A4	22.06.2005
		EP 1888739 A2	20.02.2008
		GB 201105321 D0	11.05.2011
		GB 2477648 A	10.08.2011
		JP 2009-506300 A	12.02.2009
		US 2003-0017075 A1	23.01.2003
		US 2003-0170144 A1	11.09.2003
		US 2005-0053526 A1	10.03.2005
		US 2005-0054079 A1	10.03.2005
		US 2005-0054080 A1	10.03.2005
		US 2006-0275861 A1	07.12.2006
		US 2006-0275889 A1	07.12.2006
		US 2006-0281116 A1	14.12.2006
		US 2007-0231889 A1	04.10.2007
		US 2008-0318305 A1	25.12.2008
		US 2009-0270599 A1	29.10.2009
		US 2009-0326621 A1	31.12.2009
		US 2010-0009429 A1	14.01.2010
		US 2010-0028978 A1	04.02.2010
		US 2010-0068096 A1	18.03.2010
		US 2010-0068102 A1	18.03.2010
		US 2011-0150725 A1	23.06.2011
		US 6534008 B1	18.03.2003
		US 6855292 B2	15.02.2005
		US 7250301 B2	31.07.2007
		US 7476362 B2	13.01.2009
		US 7622077 B2	24.11.2009
		US 7632461 B2	15.12.2009
		US 7897106 B2	01.03.2011
		US 7951612 B2	31.05.2011
		US 8007720 B2	30.08.2011
		US 8007721 B2	30.08.2011
		US 8052927 B2	08.11.2011
		US 8071023 B2	06.12.2011
		US 8092742 B2	10.01.2012
		US 8298485 B2	30.10.2012
		US 8361388 B2	29.01.2013
		US 8377377 B2	19.02.2013
		WO 01-04634 A1	18.01.2001
		WO 2006-127852 A2	30.11.2006
		WO 2006-127852 A3	29.03.2007

INTERNATIONAL SEARCH REPORT

Information on patent family members

International application No.

PCT/US2013/000019

Patent document cited in search report	Publication date	Patent family member(s)	Publication date
		WO 2006-127897 A2	30.11.2006
		WO 2006-127897 A3	14.06.2007
		WO 2010-025425 A1	04.03.2010
US 6794052 B2	21.09.2004	AU 1998-95998 A1	27.04.1999
		AU 1999-37425 A1	25.10.1999
		AU 1999-62552 A1	10.04.2000
		AU 2000-27227 A1	24.07.2000
		CA 2261305 A1	29.01.1998
		CA 2261305 C	21.03.2006
		CA 2267897 A1	16.04.1998
		CA 2267897 C	06.12.2005
		CA 2267908 A1	16.04.1998
		CA 2267908 C	09.07.2002
		CA 2290394 A1	14.10.1999
		CA 2290394 C	28.02.2006
		CA 2297657 A1	04.02.1999
		CA 2344946 A1	10.11.2001
		CA 2347326 A1	10.11.2001
		CA 2527935 A1	14.10.1999
		CA 2527935 C	12.02.2008
		CN 1082936 C	17.04.2002
		CN 1181055 A	06.05.1998
		EP 0789671 A1	08.12.2004
		EP 0789671 B1	26.07.2006
		EP 0917494 A1	04.08.2004
		EP 0923590 A1	10.10.2001
		EP 0923590 B1	10.10.2001
		EP 0934515 A1	24.04.2002
		EP 0934515 B1	08.03.2006
		EP 0943091 A1	15.05.2002
		EP 0943091 B2	29.09.2010
		EP 0978499 A2	09.02.2000
		EP 0978499 A3	05.07.2000
		EP 0978499 B1	14.11.2001
		EP 0978499 B2	05.05.2010
		EP 0983983 A2	08.03.2000
		EP 0983983 A3	05.07.2000
		EP 0983983 B1	12.12.2001
		EP 0985678 A2	15.03.2000
		EP 0985678 A3	05.07.2000
		EP 0985678 B1	05.12.2001
		EP 0989820 A1	05.04.2000
		EP 0992281 A2	12.04.2000
		EP 0992281 A3	16.08.2000
		EP 1000074 A1	17.05.2000
		EP 1002572 A2	24.05.2000
		EP 1002572 A3	20.09.2000
		EP 1002572 B1	06.12.2006
		EP 1002573 A2	24.05.2000

INTERNATIONAL SEARCH REPORT

Information on patent family members

International application No.

PCT/US2013/000019

Patent document cited in search report	Publication date	Patent family member(s)	Publication date
		EP 1002573 A3	16.08.2000
		EP 1018002 A2	12.07.2000
		EP 1019947 A2	19.07.2000
		EP 1021711 A2	26.07.2000
		EP 1062033 A1	27.12.2000
		EP 1113991 A2	11.07.2001
		EP 1113991 B1	09.06.2004
		EP 1160262 A1	05.12.2001
		EP 1280185 A1	29.01.2003
		EP 1280185 B1	22.09.2004
		EP 1308722 A2	07.05.2003
		EP 1308722 A3	04.08.2004
		EP 1308723 A2	07.05.2003
		EP 1308723 A3	11.08.2004
		EP 1310789 A2	14.05.2003
		EP 1310789 A3	04.08.2004
		EP 1310791 A2	14.05.2003
		EP 1310791 A3	04.08.2004
		EP 1361428 A2	12.11.2003
		EP 1361429 A2	12.11.2003
		EP 1442788 A2	04.08.2004
		EP 1442788 A3	15.09.2004
		EP 1442788 B1	02.11.2005
		EP 1479435 A1	24.11.2004
		EP 1479435 B1	22.02.2006
		EP 1481726 A1	01.12.2004
		EP 1481726 B1	29.03.2006
		EP 1579908 A1	28.09.2005
		EP 1579908 B1	14.10.2009
		EP 1669738 A2	14.06.2006
		EP 1669738 A3	12.12.2007
		EP 1754533 A2	21.02.2007
		EP 1754533 A3	24.09.2008
		JP 10-512840 A	08.12.1998
		JP 11-514012 A	30.11.1999
		JP 2000-503753 A	28.03.2000
		JP 2002-055105 A	20.02.2002
		JP 2002-501622 A	15.01.2002
		JP 2004-163418 A	10.06.2004
		JP 2009-155319 A	16.07.2009
		JP 2009-155633 A	16.07.2009
		JP 3893152 B2	14.03.2007
		JP 4324682 B2	02.09.2009
		JP 4814298 B2	16.11.2011
		KR 10-0407357 B1	31.05.2004
		US 2001-0010174 A1	02.08.2001
		US 2001-0033375 A1	25.10.2001
		US 2001-0049090 A1	06.12.2001
		US 2001-0053528 A1	20.12.2001
		US 2001-0055669 A1	27.12.2001

INTERNATIONAL SEARCH REPORT

Information on patent family members

International application No.

PCT/US2013/000019

Patent document cited in search report	Publication date	Patent family member(s)	Publication date
		US 2001-0055775 A1	27.12.2001
		US 2002-0098471 A1	25.07.2002
		US 2002-0119243 A1	29.08.2002
		US 2002-0178787 A1	05.12.2002
		US 2002-0197454 A1	26.12.2002
		US 2002-0197731 A1	26.12.2002
		US 2003-0007152 A1	09.01.2003
		US 2003-0041653 A1	06.03.2003
		US 2003-0086822 A1	08.05.2003
		US 2003-0100119 A1	29.05.2003
		US 2003-0129768 A1	10.07.2003
		US 2003-0134089 A1	17.07.2003
		US 2003-0138025 A1	24.07.2003
		US 2003-0219906 A1	27.11.2003
		US 2004-0014077 A1	22.01.2004
		US 2004-0023302 A1	05.02.2004
		US 2004-0074302 A1	22.04.2004
		US 2004-0074303 A1	22.04.2004
		US 2004-0154704 A1	12.08.2004
		US 2004-0175760 A1	09.09.2004
		US 2005-0009081 A1	13.01.2005
		US 2005-0164304 A1	28.07.2005
		US 2005-0260332 A1	24.11.2005
		US 2008-0011111 A1	17.01.2008
		US 2009-0002708 A1	01.01.2009
		US 5776359 A	07.07.1998
		US 5959297 A	28.09.1999
		US 5985356 A	16.11.1999
		US 6004617 A	21.12.1999
		US 6013199 A	11.01.2000
		US 6030917 A	29.02.2000
		US 6034775 A	07.03.2000
		US 6045671 A	04.04.2000
		US 6182499 B1	06.02.2001
		US 6203726 B1	20.03.2001
		US 6242623 B1	05.06.2001
		US 6248540 B1	19.06.2001
		US 6326090 B1	04.12.2001
		US 6336353 B2	08.01.2002
		US 6346290 B1	12.02.2002
		US 6373570 B1	16.04.2002
		US 6393895 B1	28.05.2002
		US 6401519 B1	11.06.2002
		US 6410331 B1	25.06.2002
		US 6419881 B1	16.07.2002
		US 6420179 B1	16.07.2002
		US 6440745 B1	27.08.2002
		US 6441901 B2	27.08.2002
		US 6494079 B1	17.12.2002
		US 6508984 B1	21.01.2003

INTERNATIONAL SEARCH REPORT

Information on patent family members

International application No.

PCT/US2013/000019

Patent document cited in search report	Publication date	Patent family member(s)	Publication date
		US 6536944 B1	25.03.2003
		US 6541271 B1	01.04.2003
		US 6576906 B1	10.06.2003
		US 6649413 B1	18.11.2003
		US 6653138 B1	25.11.2003
		US 6670298 B1	30.12.2003
		US 6686205 B1	03.02.2004
		US 6720186 B1	13.04.2004
		US 6738529 B1	18.05.2004
		US 6756195 B2	29.06.2004
		US 6828096 B1	07.12.2004
		US 6833921 B2	21.12.2004
		US 6849460 B2	01.02.2005
		US 6864201 B2	08.03.2005
		US 6872534 B2	29.03.2005
		US 6904786 B2	14.06.2005
		US 6957565 B2	25.10.2005
		US 7034091 B2	25.04.2006
		US 7073370 B2	11.07.2006
		US 7076115 B2	11.07.2006
		US 7166470 B2	23.01.2007
		US 7242000 B2	10.07.2007
		US 7320858 B2	22.01.2008
		US 7334452 B2	26.02.2008
		US 7364697 B2	29.04.2008
		US 7442665 B2	28.10.2008
		US 7551285 B2	23.06.2009
		US 7767627 B1	03.08.2010
		WO 00-40331 A1	13.07.2000
		WO 00-60529 A1	12.10.2000
		WO 96-11878 A1	25.04.1996
		WO 98-03521 A1	29.01.1998
		WO 98-15805 A1	16.04.1998
		WO 98-15813 A1	16.04.1998
		WO 98-47613 A1	29.10.1998
		WO 98-55016 A1	10.12.1998
		WO 98-56796 A1	17.12.1998
		WO 99-05154 A1	04.02.1999
		WO 99-05318 A1	04.02.1999
		WO 99-18431 A1	15.04.1999
US 2003-0143612 A1	31.07.2003	US 2002-0137053 A1	26.09.2002
US 2005-0035983 A1	17.02.2005	AU 2003-287618 A1	03.06.2004
		US 2007-0008390 A1	11.01.2007
		US 2010-0242765 A1	30.09.2010
		US 7034854 B2	25.04.2006
		US 7762638 B2	27.07.2010
		WO 2004-044552 A2	27.05.2004
		WO 2004-044552 A3	02.09.2004

INTERNATIONAL SEARCH REPORT

Information on patent family members

International application No.

PCT/US2013/000019

Patent document cited in search report	Publication date	Patent family member(s)	Publication date
US 2010-0160181 A1	24.06.2010	US 7682009 B1	23.03.2010