

J. STRANDERS.  
 ADVERTISING DEVICE.  
 APPLICATION FILED APR. 26, 1912.

1,069,494.

Patented Aug. 5, 1913.

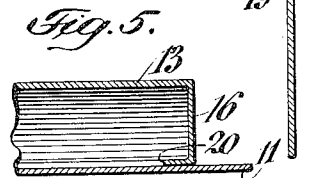
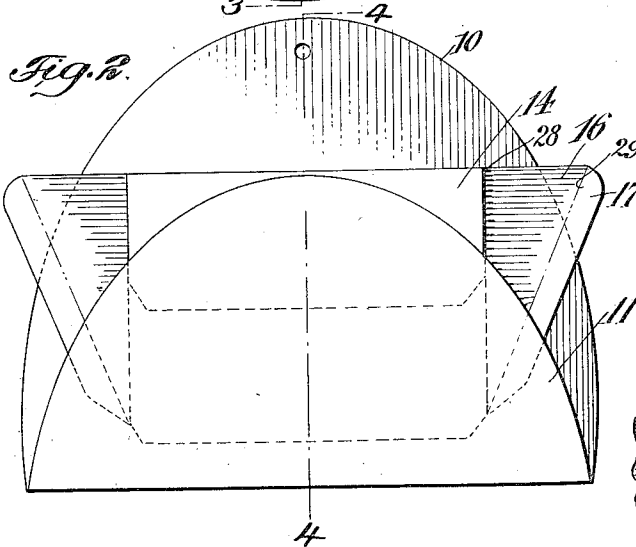
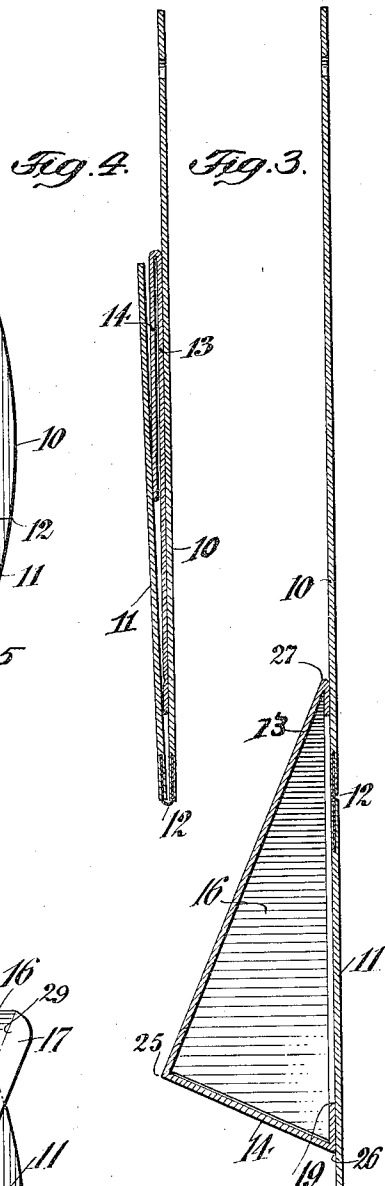
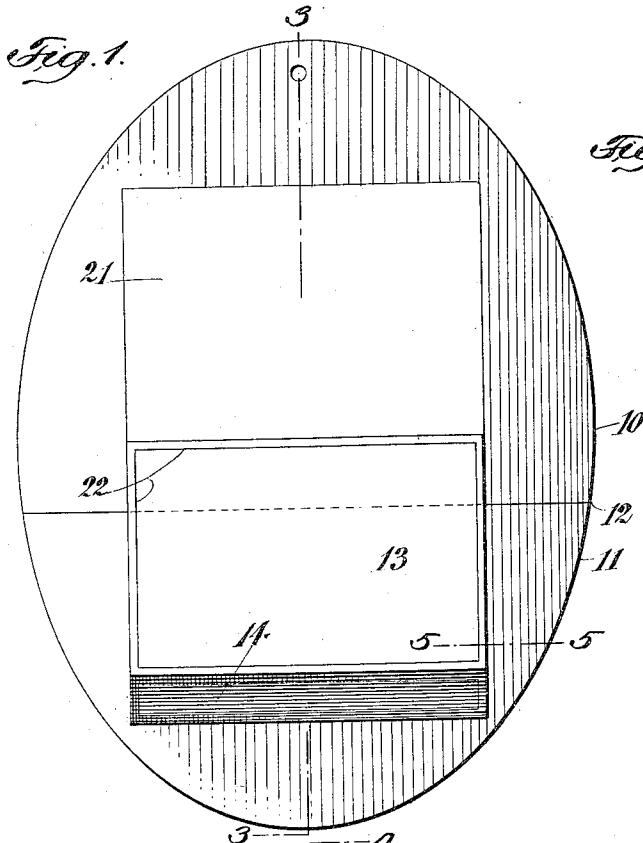

Witnesses:  
*Julius Smith*  
*John Murtagh*

Inventor  
*Julien Stranders*  
 By *Wm. L. ...*  
*Wm. L. ...*

# UNITED STATES PATENT OFFICE.

JULIEN STRANDERS, OF NEW YORK, N. Y.

ADVERTISING DEVICE.

1,069,494.

Specification of Letters Patent.

Patented Aug. 5, 1913.

Application filed April 26, 1912. Serial No. 693,450.

*To all whom it may concern:*

Be it known that I, JULIEN STRANDERS, a subject of the King of Great Britain, and a resident of New York, borough of Brooklyn, county of Kings, and State of New York, have invented certain new and useful Improvements in Advertising Devices, of which the following is a specification.

This invention relates to advertising devices, and has for its object to provide an improved device by means of which a dummy container having the goods desired to be advertised therein may be represented. Such a dummy may be a box of cigars or a box of candies, and may be shown in a manner closely resembling an original container when the device is in operation.

The object of the invention is to provide an advertising device which when in operative position will show the dummy container, while when in inoperative position it may be conveniently folded and easily shipped from place to place.

For this purpose my invention consists of an improved advertising device, comprising a foldable back part and a collapsible dummy container thereon so arranged that when in operative position the dummy container will be in extended position while when in inoperative position the dummy container will be in collapsed position.

In the accompanying drawings, Figure 1 shows a front-view of my improved advertising device, showing the same in open operative position with the dummy container extended, Fig. 2 is a view showing the collapsed parts and in inoperative position, Fig. 3 is a vertical section, taken through line 3-3 of Fig. 1, showing the dummy container in extended position, Fig. 4 is a vertical section taken through line 4-4 of Fig. 2, showing the dummy container in collapsed position, Fig. 5 is a detailed section, taken on line 5-5 of Fig. 1.

Similar characters of reference indicate corresponding parts throughout the several figures of the drawings.

Referring to the drawings, and more particularly to Fig. 1, the back part is composed of two plates 10 and 11 which are hinged at 12 by means of which the parts may be brought in operative position, as shown in Fig. 1, or in inoperative position, as shown in Fig. 4, by swinging either part in respect to the other around the hinge 12. The upper part 10 is provided with an indi-

cation thereon intended to depict the inside part of the cover of the dummy container, as is indicated by 21 and has hinged thereto at the lower part of this part 21 a face member 13 which acts as a top part of the dummy container. The face member 13 is provided with a depending portion 14 which is hinged to the face member 13 at 25 and the depending portion 14 is hinged at 26 to the back part 11. The face member 13 is hinged at 27 to the upper part 10 by any suitable means as by the folding of a suitable material, such as cardboard, etc. of which the dummy container is made. The face member 13 is provided at its sides with depending portions 16 which are hinged at 28 to the face member by means of folds or otherwise, and to these portions 16 are hinged at 29 brace-portions 17. When the dummy container is in open position as shown in Figs. 1 and 3, the folding side members 16 serve to span the hinge 12 and operate to lock the parts 10 and 11 of the base plate in said open position and also to support the parts 13 and 14 of the face member in inclined positions. When, therefore, it is desirable to collapse the device, the side-portions 16 after their brace-portions 17 are moved laterally away from the face member 13 and by reason thereof no resistance being offered to the parts, all the parts may readily collapse into the position shown in Figs. 2 and 4.

By providing the container 13 with a suitable picture, as for instance, a plurality of cigars and providing the part 21 with a picture corresponding to the trademark or label of the cigars, a device is produced which closely resembles the real box of cigars in a position intended to enable anyone to take a cigar out of the box and thus forms a very desirable advertising device. In other cases, the cover 13 might be provided with a picture corresponding to chocolates or candies and the part 21 provided with a suitable and corresponding label.

By being able to collapse the parts into their inoperative position, as shown in Figs. 2 and 4, the advertising device may be readily transported from place to place, while the extended position or operative position of the advertising device serves a very desirable purpose.

I claim:

An advertising device consisting of a collapsible dummy container comprising a fold-

110

ing base plate composed of two sections  
transversely hinged to fold one over the  
other, a folding face member secured at its  
upper and lower ends to said sections re-  
spectively within a space shorter than itself  
5 and having a transverse fold parallel with  
the fold of said base plate, and folding side  
members hinged to opposite sides of one part  
of said face member and adapted to span the

fold in said base plate and lock the device in 10  
open position.

In testimony, that I claim the foregoing  
as my invention, I have signed my name in  
presence of two subscribing witnesses.

JULIEN STRANDERS.

Witnesses:

JOHN MURTAGH,  
L. M. DORMSIE.

Copies of this patent may be obtained for five cents each, by addressing the "Commissioner of Patents,  
Washington, D. C."