

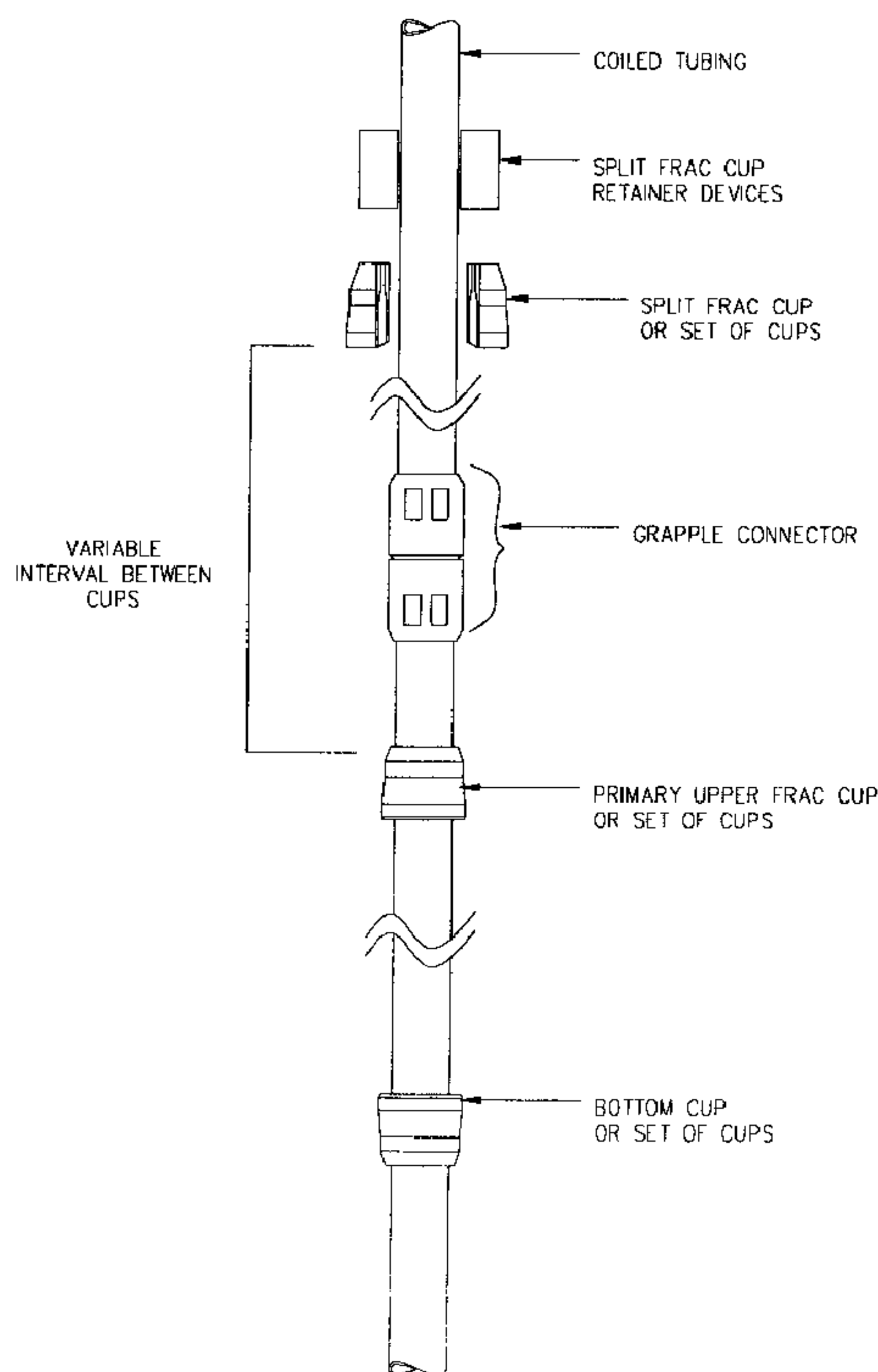

(22) Date de dépôt/Filing Date: 2006/01/06
(41) Mise à la disp. pub./Open to Public Insp.: 2007/07/06

(51) Cl.Int./Int.Cl. *E21B 33/126* (2006.01),
E21B 33/12 (2006.01)
(71) Demandeur/Applicant:
TRICAN WELL SERVICE LTD., CA
(72) Inventeurs/Inventors:
MOORE, DARYL, CA;
BROCKLEBANK, TOM, CA;
SHERMAN, SCOTT, CA
(74) Agent: STIKEMAN ELLIOTT LLP

(54) Titre : COUPELLES A PACKER
(54) Title: PACKER CUPS



CONFIGURATION WITH SECONDARY
UPPER SPLIT CUP

(57) **Abrégé/Abstract:**

Split and moveable packer cups for use above a conventional coiled tubing fracturing tool to be used for a secondary pressure containment device to avoid pressure communication with uphole formations.

Abstract

Split and moveable packer cups for use above a conventional coiled tubing fracturing tool to be used for a secondary pressure containment device to avoid pressure communication with uphole formations .

PACKER CUPS

FIELD OF THE INVENTION

This invention relates to hydraulically fracturing subterranean formations with coiled tubing for improved production of oil and gas, and in particular, to packer cups.

BACKGROUND OF THE INVENTION

Hydraulically fracturing subterranean formations to increase oil and gas production has become a routine operation in the petroleum industry. In hydraulic fracturing, a fracturing fluid is injected through a wellbore into the formation at a pressure and flow rate sufficient to overcome the overburden stress and to initiate a fracture in the formation. The fracturing fluid may be a water-based liquid, oil-based liquid, liquefied gas such as but not limited to carbon dioxide, dry gases such as but not limited to nitrogen, or combination of liquefied and dry gases, or some combination of any of these or other fluids. It is most common to introduce a proppant into the fracturing fluid, whose function is to prevent the created fractures from closing back down upon itself when the pressure is released. The proppant is suspended in the fracturing fluid and transported into a fracture. Proppants in use include 20-40 mesh size sand, ceramics, and other materials that provide a high-permeability channel within the fracture to allow for greater flow of oil or gas from the formation to the wellbore. Production of petroleum or natural gas can be enhanced significantly by the use of these techniques.

Hydraulic fracturing with coiled tubing is a common operation. It generally uses a bottomhole assembly comprised of opposing sets of one or more pressure-containing cups fixed to a length of piping typically heavier in wall thickness than the coiled tubing string. The distance between the two sets of opposing fracture cups determine the length of formation interval to be fractured by virtue of the fact

that the cups are fixed to the bottomhole assembly. In typical operations, it is desirable to leave the well in a live condition, meaning it is left to flow while operations are being conducted and is not killed with water or heavier liquids. In the case of live-well operations, coiled tubing is seen as having a significant advantage over jointed pipe operations as pressure control at surface is continuous while moving the coiled tubing in and out of the well and there are no joints to be made in the string after the tools are in the wellbore.

To effect a live-well operation, tools used for fracturing are lubricated in and out of the wellbore, a process in which the tools are attached to the coiled tubing and housed in a length of pressure-integral piping known as lubricator and attached to the wellbore above the coiled tubing blowout preventers (BOPs), which themselves are attached to a pressure control valve, commonly referred to as a master valve. After connecting the lubricator housing the coiled tubing fracturing tool and coiled tubing to the master valve, the lubricator system is tested to ensure it holds wellbore pressure without leaking. Well pressure is then contained by the coiled tubing stripper or stuffing box, situated between the lubricator and the injector. Once pressure integrity of the system has been established through testing, the master valve can be opened and the fracturing tool and coiled tubing run into the wellbore to the desired depth for fracturing operations, with the entire operation conducted under live conditions.

This conventional method of fracturing with coiled tubing is illustrated in Figures 1 and 2.

In conducting these operations, it is not uncommon for the fracture initiated in one zone or zones to breakthrough behind the casing to an upper zone or zones through open perforations in the casing, thereby reducing the effectiveness of the current fracture treatment, and also potentially impairing future fracture treatments on the upper zone or zones. This possible occurrence is illustrated in Figure 3.

DESCRIPTION OF THE INVENTION

The present invention in one embodiment is a set of opposing fracture cups for use in fracturing a subterranean formation using coiled tubing. An additional upper cup or set of cups that can be strategically placed at a location on the coiled tubing to allow a pressure barrier inside the casing to prevent pressure communication with uphole zone or zones from within the casing.

Split Cups

In one embodiment, there is provided a common coiled tubing fracturing tool with opposing solid cups or sets of cups to contain fracture pressures between the cups or sets of cups. Unlike in conventional configurations, however, a second upper cup or set of cups is placed above the first cup or set of upper cups, but the second cup or set of upper cups are not solid one-piece in design, but rather are split or two-pieced such that they can be placed on the coiled tubing while the coiled tubing is in the wellbore without access to the end of the coiled tubing or the fracturing tool. This is illustrated in Figure 4.

A split cup design, in one embodiment according to the invention, can be used in a coiled tubing fracturing process as follows:

- A traditional coiled tubing fracturing tool is connected to the coiled tubing and lubricated into the wellbore as per conventional methods;
- A coiled tubing work window is added to the wellhead assembly between the coiled tubing BOPs and lubricator. The work window is a pressure integral device that can be opened and closed to allow access to the coiled tubing while the master valve is opened and the coiled tubing is in the wellbore. Protection from well pressure when the window is open is provided by closing the annular bag and / or pipe rams of the coiled tubing BOPs, depending on the BOP configuration required;

- The fracturing tool is run into the wellbore under live conditions to a depth determined by the desired interval of secondary pressure containment to be obtained. Once at this depth, the coiled tubing BOPs (annular bag and / or pipe rams) are activated to contain wellbore pressure, the lubricator system depressured, and the work window opened to gain access to the coiled tubing;
- With the coiled tubing exposed to atmosphere, one or more sets of split cups are attached to the coiled tubing, and held in place by one or more sets of retaining or joining means. This is illustrated in more detail in Figure 5. Embodiments of a split packer cup/matrel unit according to the invention are shown in detail in Figs. 7, 8 and 9. Embodiments of split packer cups with various means for joining together the halves of the cup are shown in Figs. 10 to 28;
- Once the split cup assembly (which includes cups and retaining means) is fixed to the coiled tubing, the work window is closed, the system pressure tested, and the BOPs opened to allow the coiled tubing to be run to the desired depth for fracturing operations; and
- At the completion of the fracturing operations, the coiled tubing is pulled out of the wellbore, the upper cup or cups are landed in the work window and removed following the reverse of the procedure used to install them on the coiled tubing.

Solid Moveable Cups

A second embodiment uses a solid one-piece secondary upper cup or cups which are placed in the desired position on the coiled tubing string by way of a set of locating rams situated in the BOP stack. The procedure would still require a work window to fix the secondary upper cup or cups to the coiled tubing string, such that

the surface equipment would be the same as described above. This procedure would be as follows:

- The secondary upper cup or set of cups are placed over the coiled tubing string before the coiled tubing is attached to the fracturing tool carrying the bottom set of cup or cups and the primary upper cup or set of cups. A retaining means may also be placed over the coiled tubing at this stage, may be integral to the secondary upper cup assembly itself, or alternatively a split retaining device may be installed at a later stage in the operation. After the secondary upper cups are put onto the coiled tubing, the frac tool is connected. The secondary upper cups are manually situated on the coiled tubing above a set of locating rams, which are situated just below the work window and are designed to hold the secondary upper cup or cups stationary while the coiled tubing is run into the well;
- The fracturing tool is run into the wellbore under live conditions to a depth determined by the desired length of interval to be fractured. Once at this depth, the coiled tubing BOPs (annular bag and / or pipe rams) are activated to contain wellbore pressure, the lubricator system depressured, and the work window opened to gain access to the coiled tubing and the secondary upper cup or cups which have been held at surface by the locating rams. This is illustrated in Figure 6;
- With the coiled tubing exposed to atmosphere, one or more sets of retaining devices are, in the case where they were installed before the tool was run in hole, operated or activated such that they are fixed to the coiled tubing and hold the upper cup in place. In the case where they were not installed before the tool was run in hole, they are now attached to the coiled tubing in the work window such that the cup or cups are held securely in place on the coiled tubing. This retaining means may be a split clamp that is joined in the

window, a helical holding device that can be wound onto the coiled tubing, or another such device that holds the cup or cups in place;

- Once the secondary upper cup assembly (which includes cups and retaining means) is fixed to the coiled tubing, the work window is closed, the system pressure tested, the BOPs opened, and the locating rams opened to allow the coiled tubing and upper cup assembly to be run to the desired depth for fracturing operations; and
- At the completion of the fracturing operations, the coiled tubing is pulled out of the wellbore, the locating rams are closed such that the upper cup or cups are landed in the work window and removed following the reverse of the procedure used to install them on the coiled tubing.

It is understood that the basis of this invention is adjustable-depth or moveable fracture cups for use on coiled tubing to provide secondary pressure containment in the event of pressure breakthrough behind casing from fracture treatments of lower zones. There are several ways in which to introduce moveable or adjustable depth cups into the wellbore on coiled tubing.

The invention, in another embodiment, relates to a method comprising injecting pressurized gas, liquid, solid proppant material, or a combination of these materials, at high rate and pressure to create, open, and propagate fractures within the formation. A coiled tubing fracturing tool is used to contain the injected pressure and material across the intended formation. The invention provides a means of strategically locating a means of secondary pressure containment to protect other formations above the intended formation in the event that pressure breaks through to those formations behind and then into the wellbore casing. The invention is not intended to be limited to the embodiments disclosed herein.

In particular, modifications to the process and devices can be made including:

- The use of specially coated or treated coiled tubing between the fracturing tool and the secondary upper cup or set of cups to protect the coiled tubing from abrasion; and
- Alternative methods of introducing the top cup or cups to the coiled tubing.

Claim

1. A packer cup for sealing an annulus within a pipe comprising two elongated hollow sleeve halves with joining means for releasably joining to form an elongated hollow sleeve.

Application number/numéro de demande: 2532295

Figures: 10 à 15

Pages: _____

DRW-IP

Unscannable items
received with this application
(Request original documents in File Prep. Section on the 10th Floor)

Documents reçus avec cette demande ne pouvant être balayés
(Commander les documents originaux dans la section de préparation des dossiers au
10ième étage)

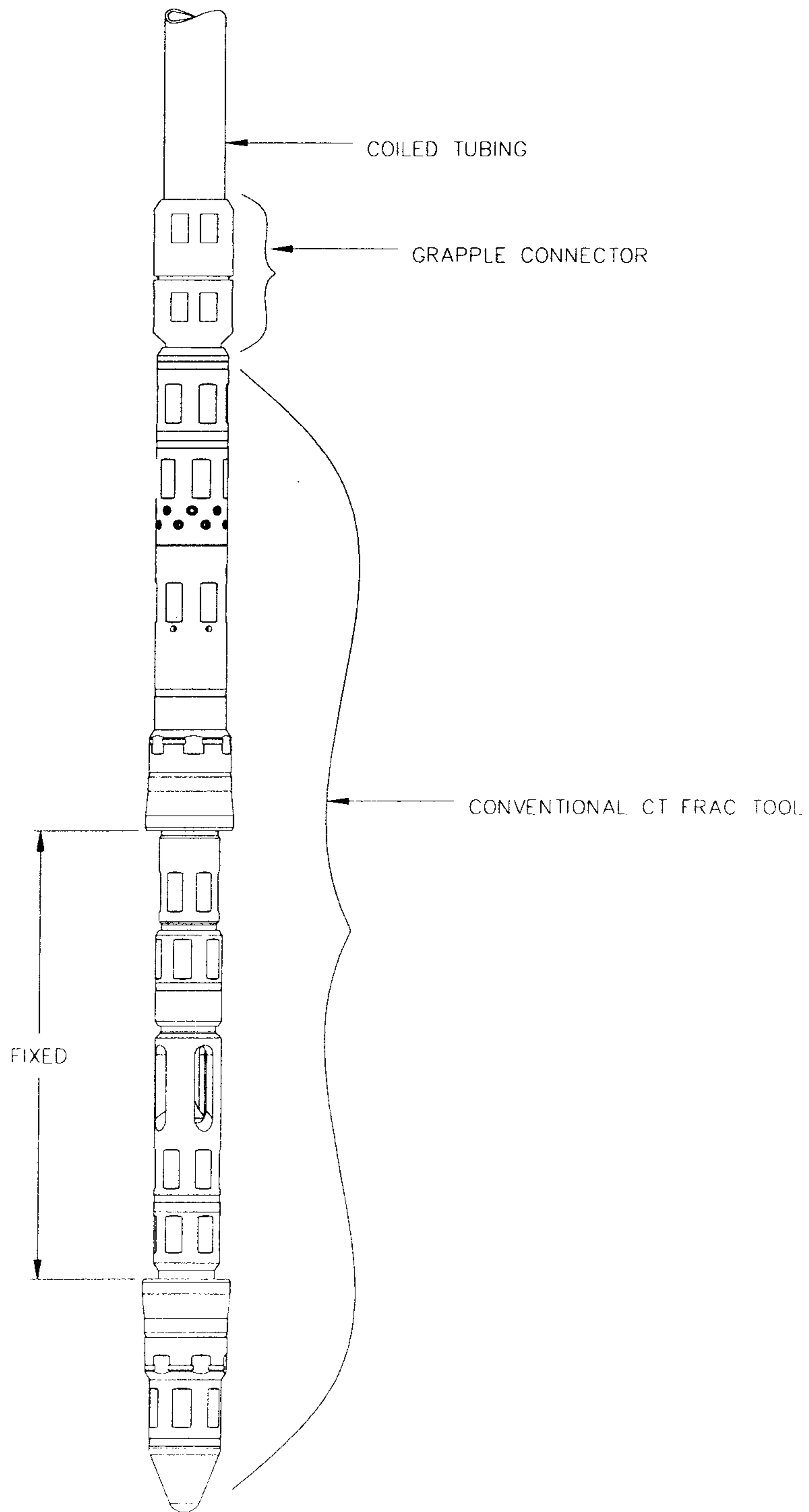

FIG. 1
CONVENTIONAL CT FRAC TOOL

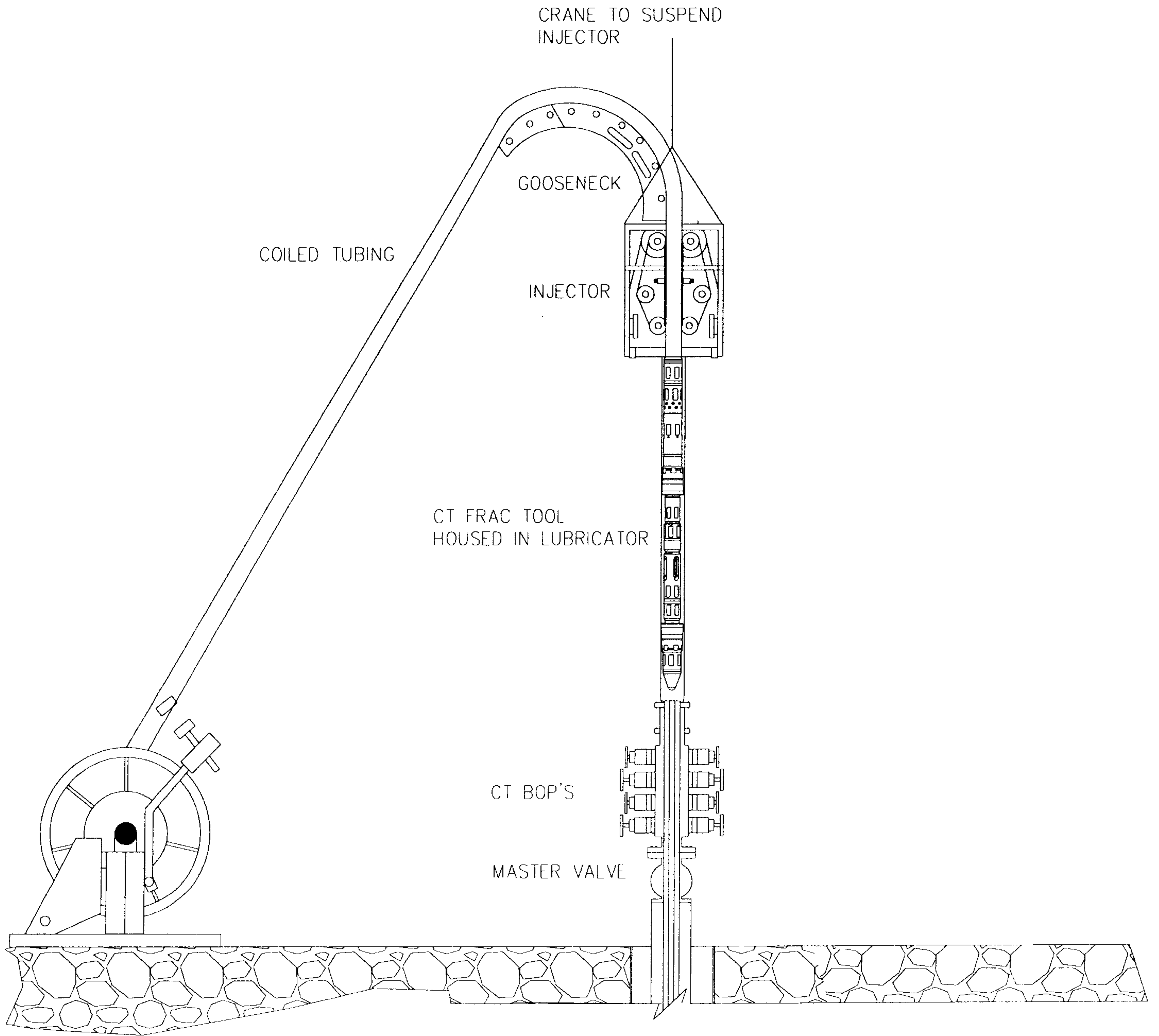

FIG. 2
CT FRACTURING EQUIPMENT LAYOUT

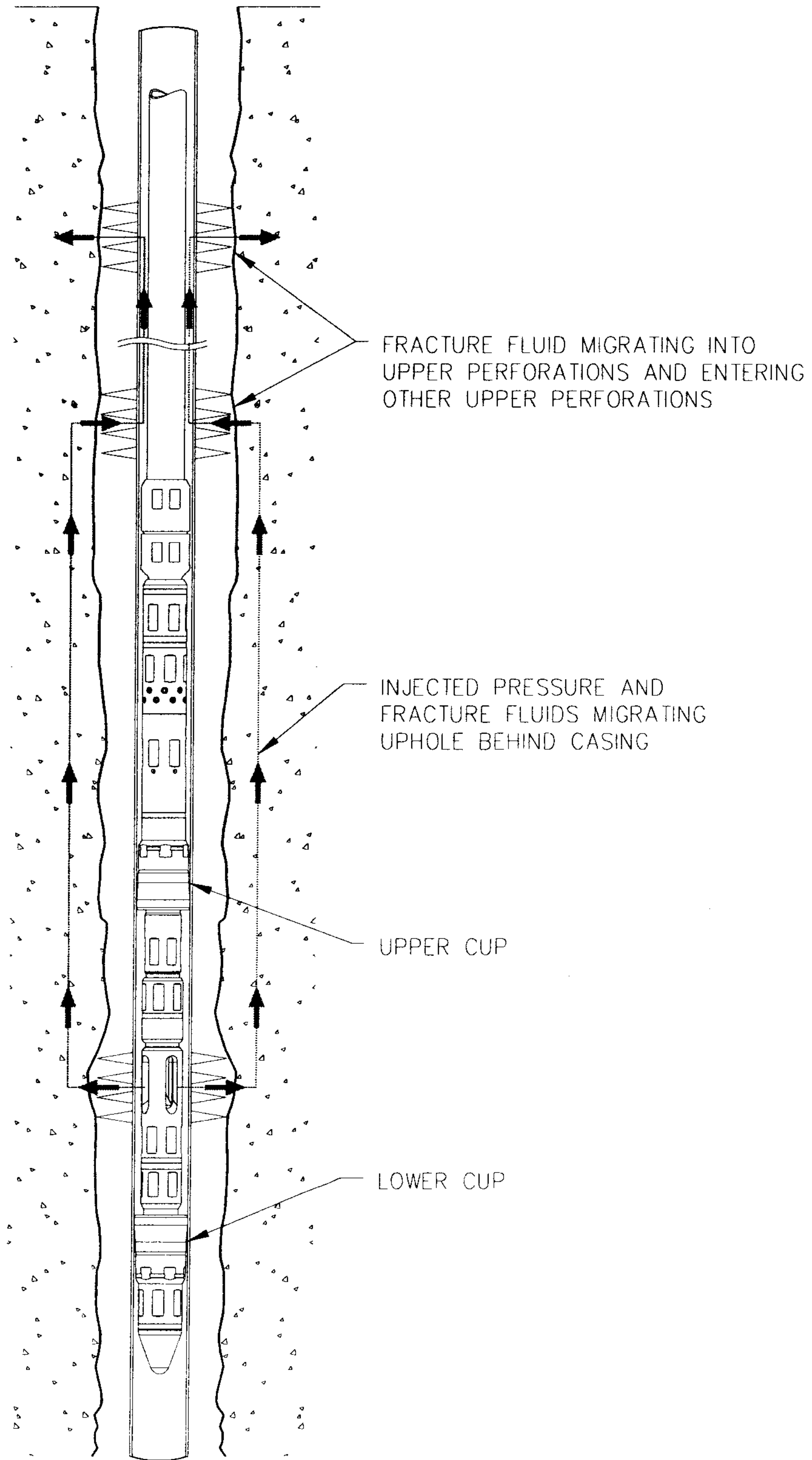

FIG. 3
CONVENTIONAL CT FRAC TOOL
WITH FRACTURE BREAKTHROUGH
TO UPPER PERFORATIONS

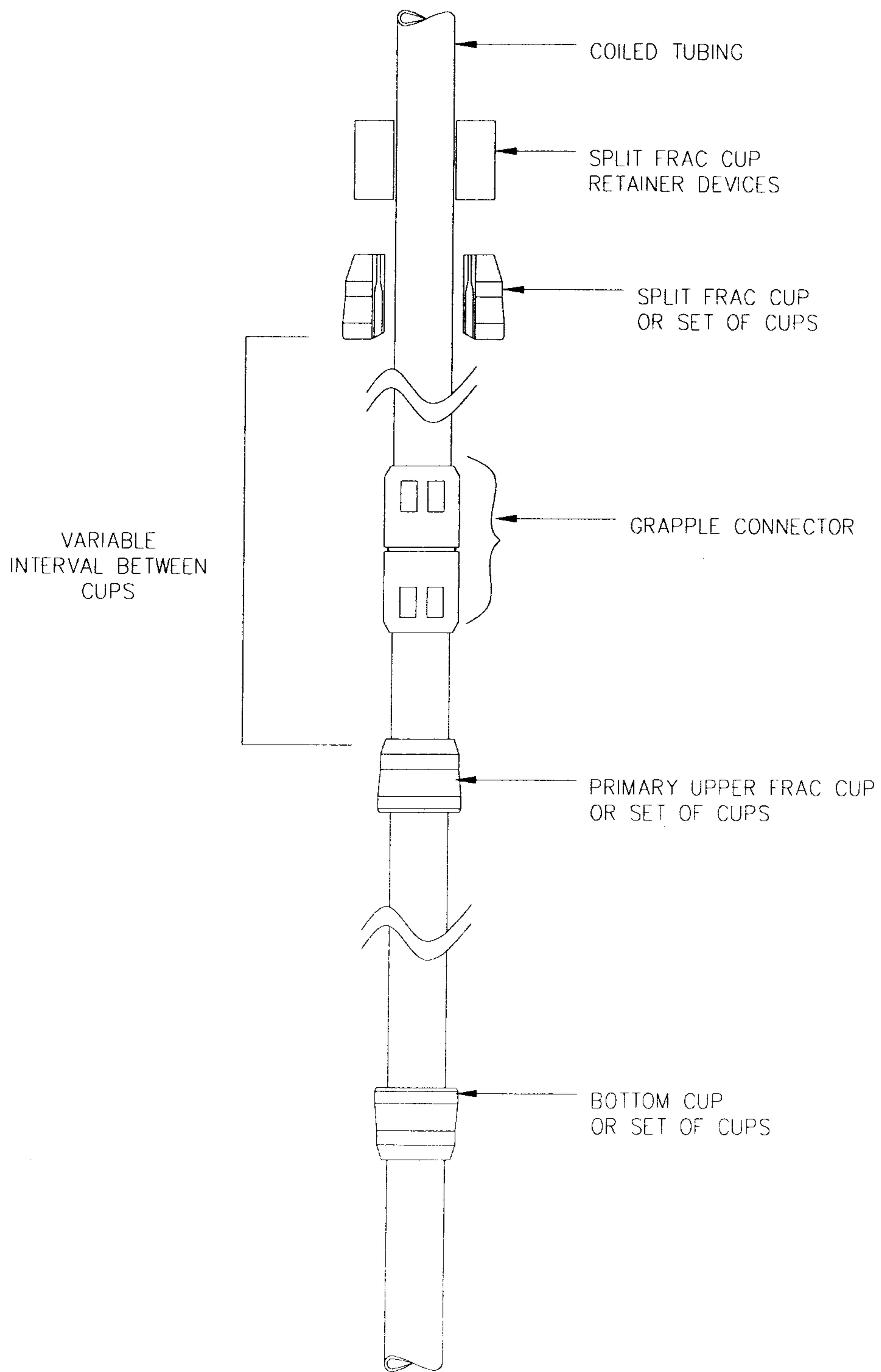

FIG. 4
CONFIGURATION WITH SECONDARY
UPPER SPLIT CUP

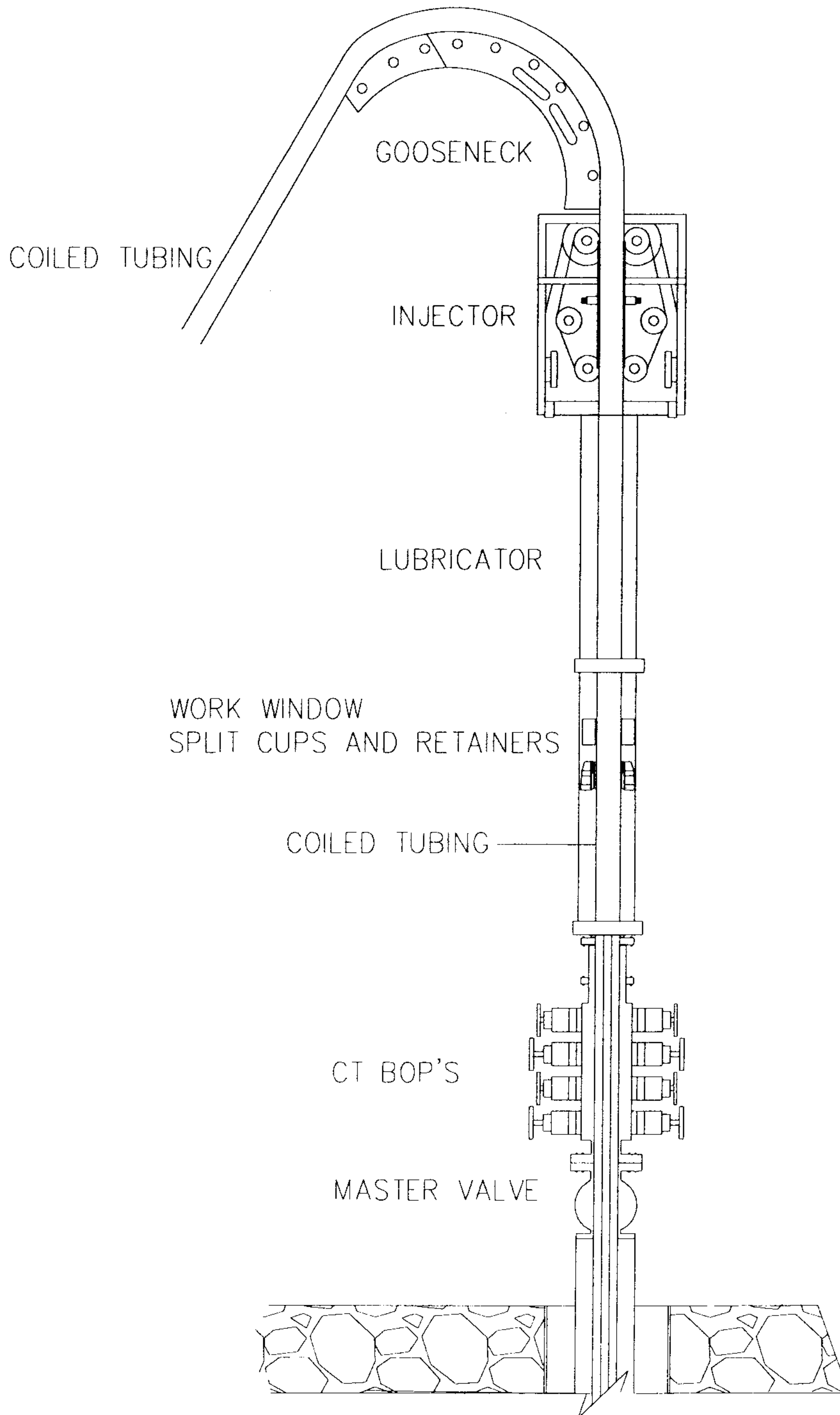

FIG. 5
INSTALLATION OF SPLIT FRAC CUPS

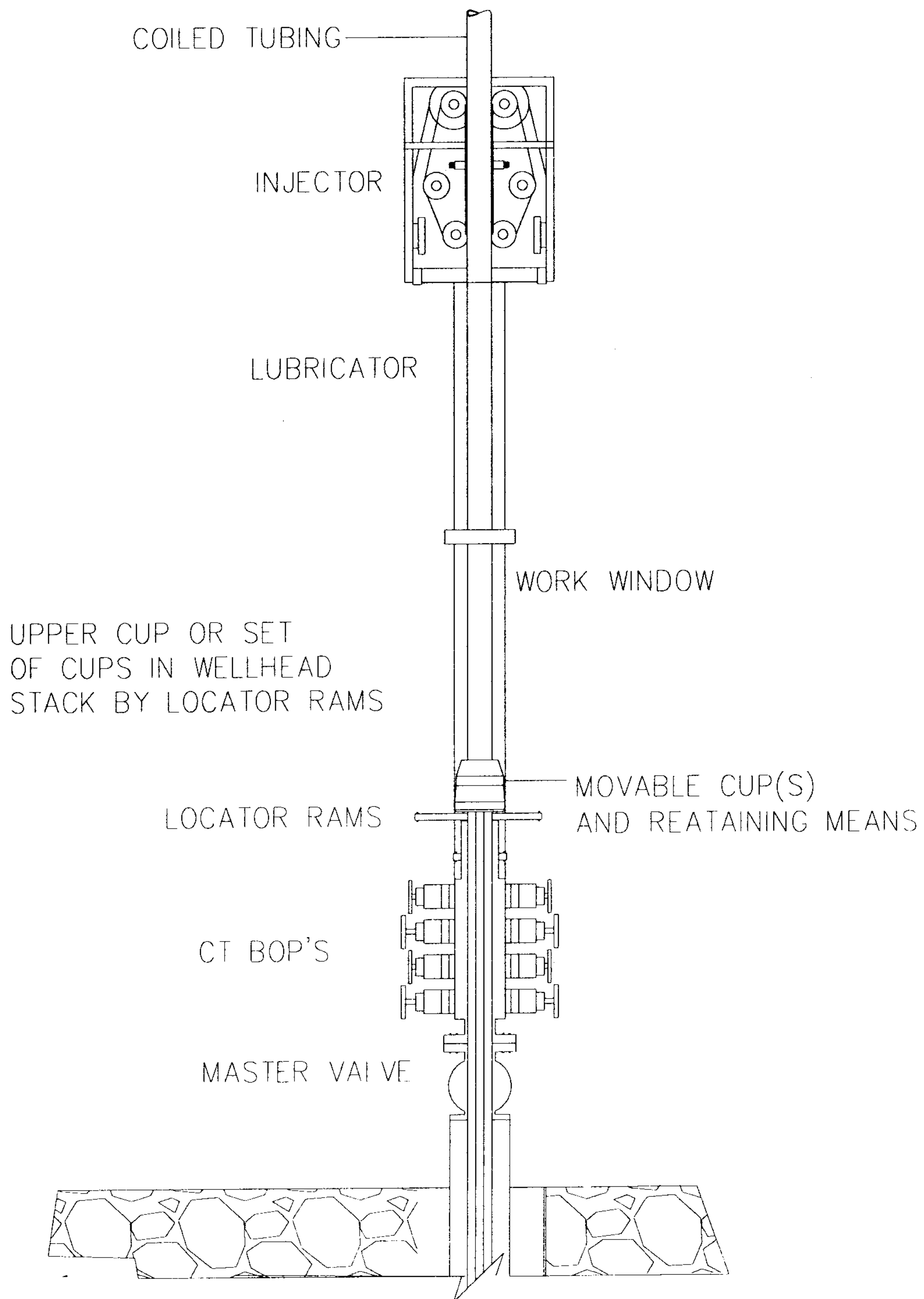

FIG. 6
INSTALLATION OF SOLID MOVABLE CUP

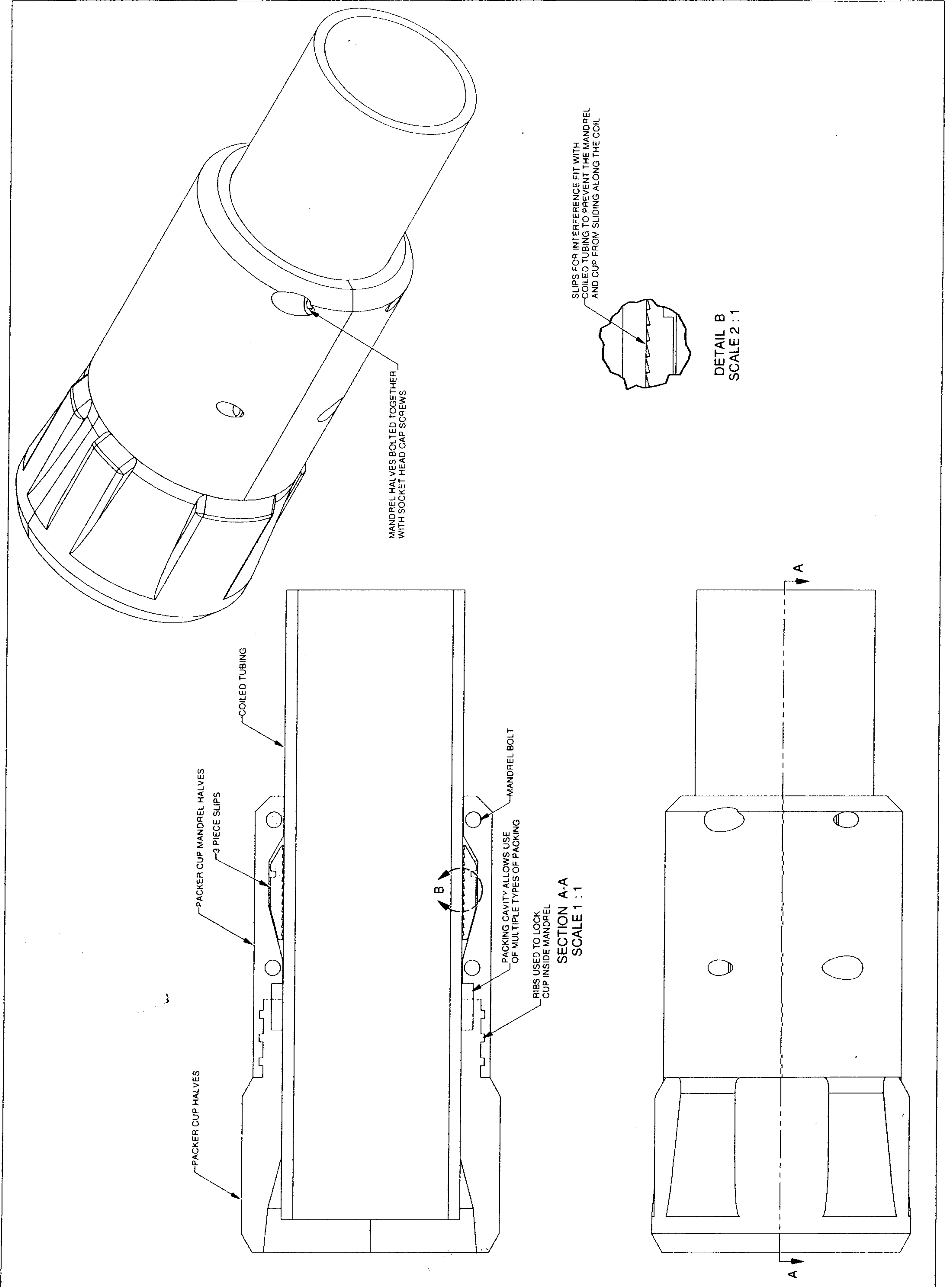

Fig. 7

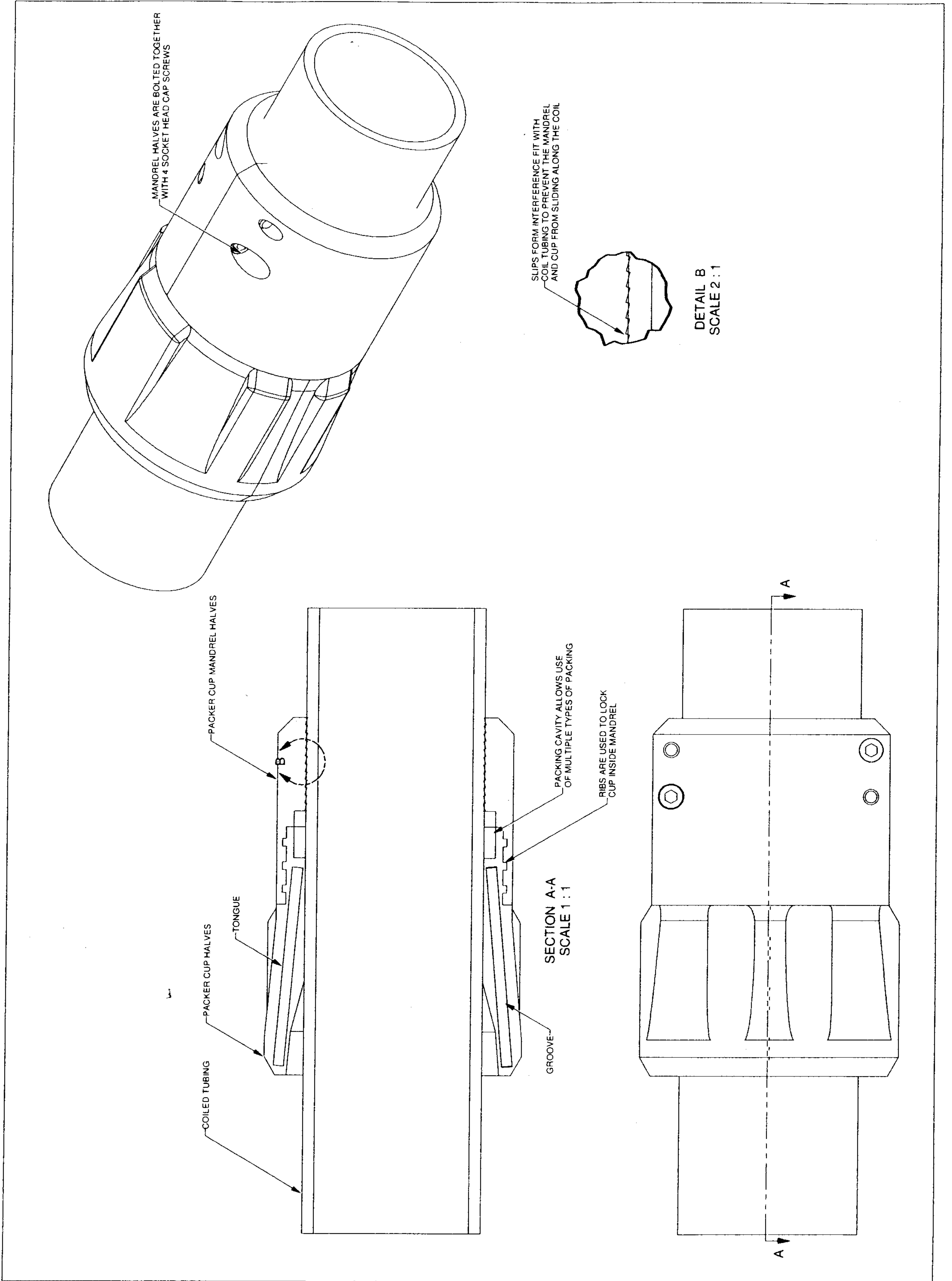

Fig. 8

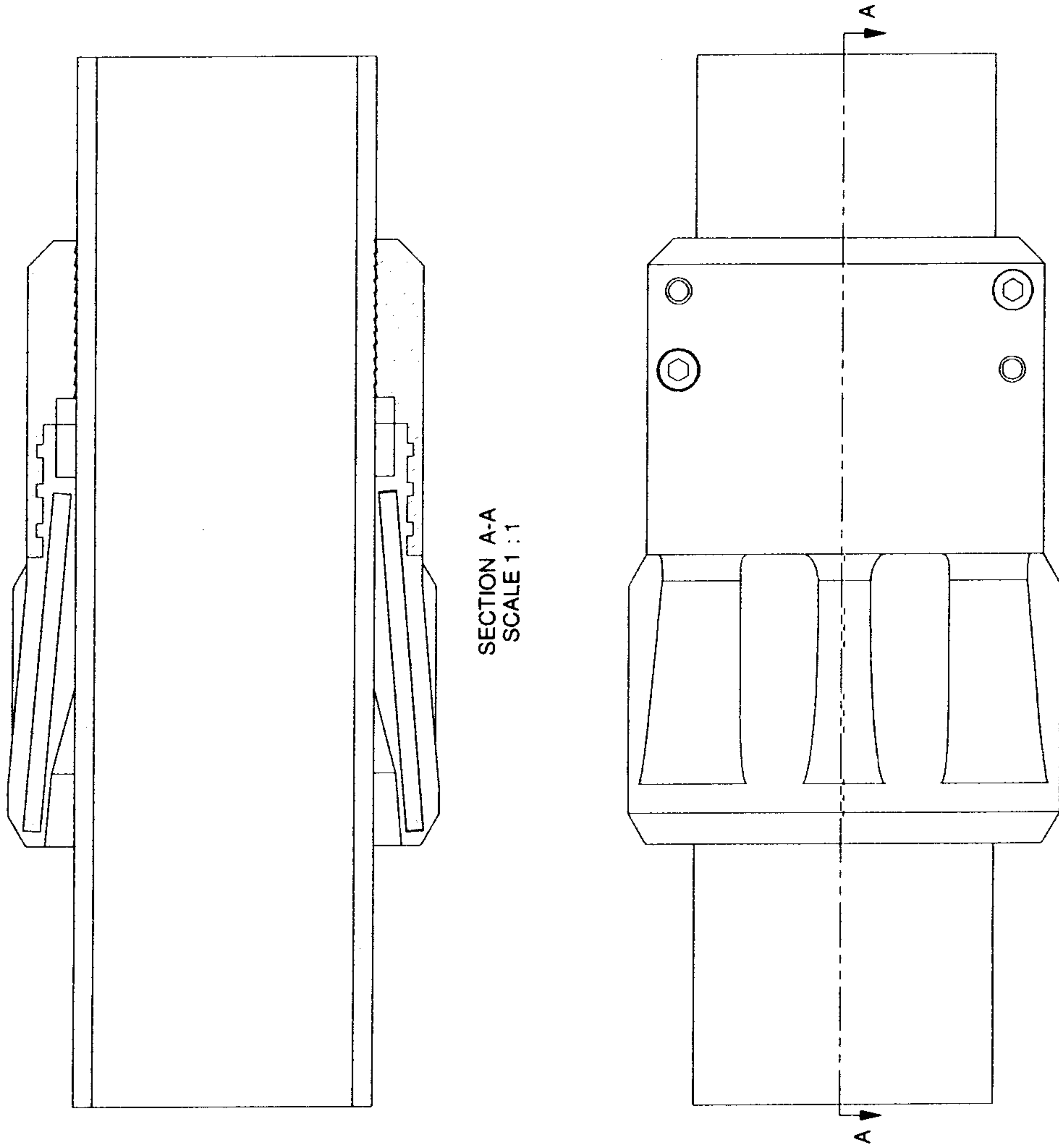
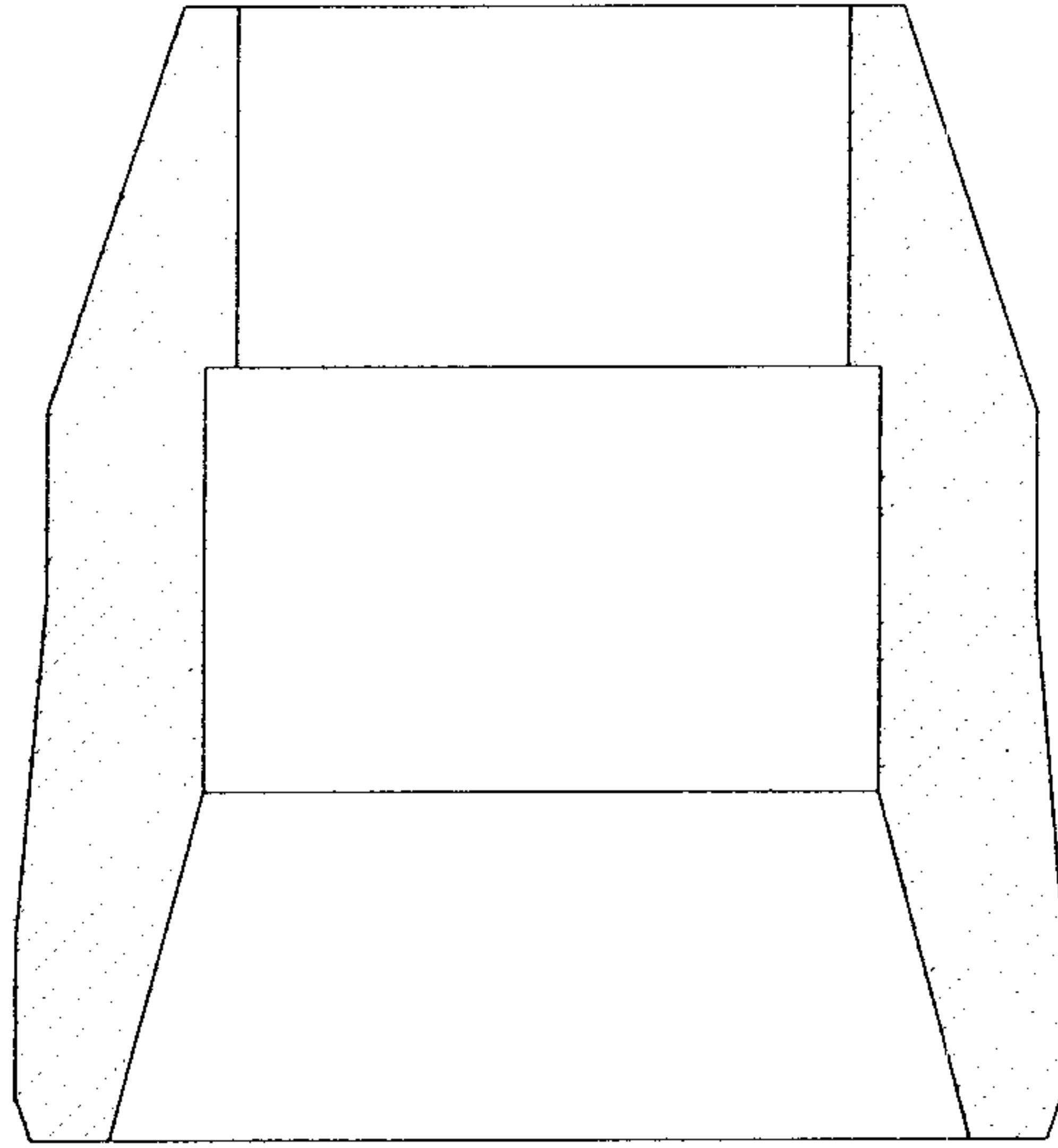

Fig. 9



SECTION C-C

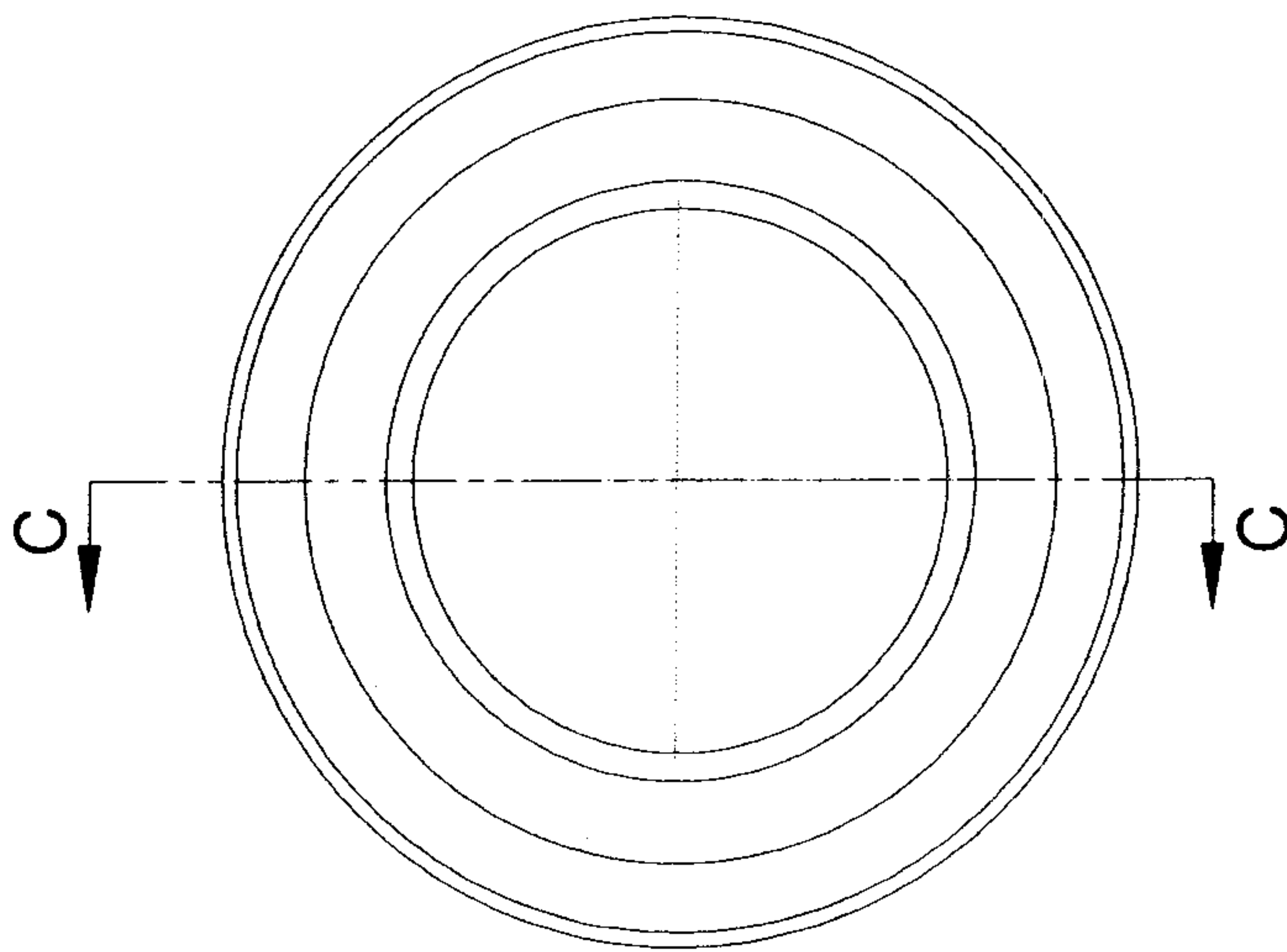
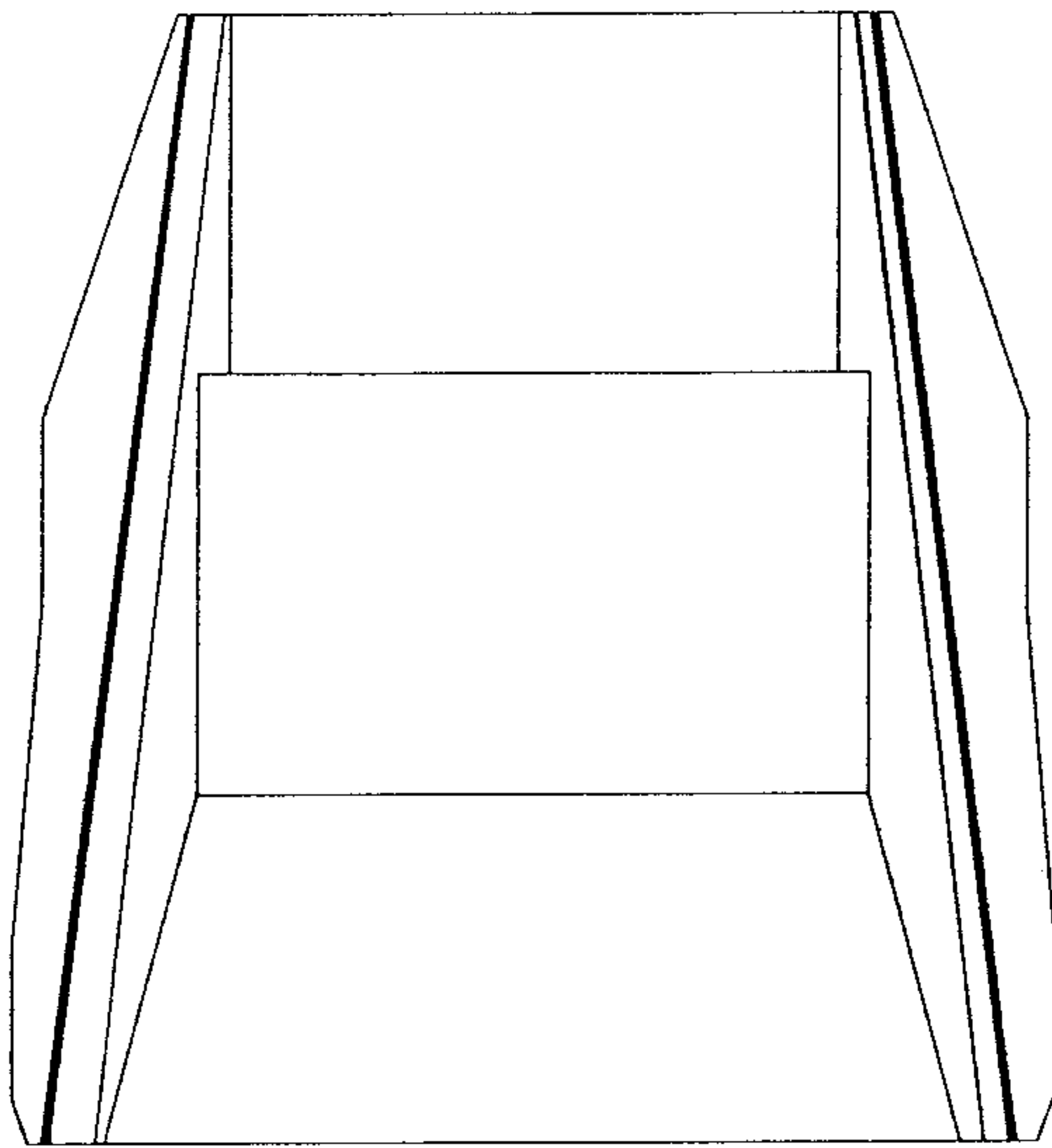
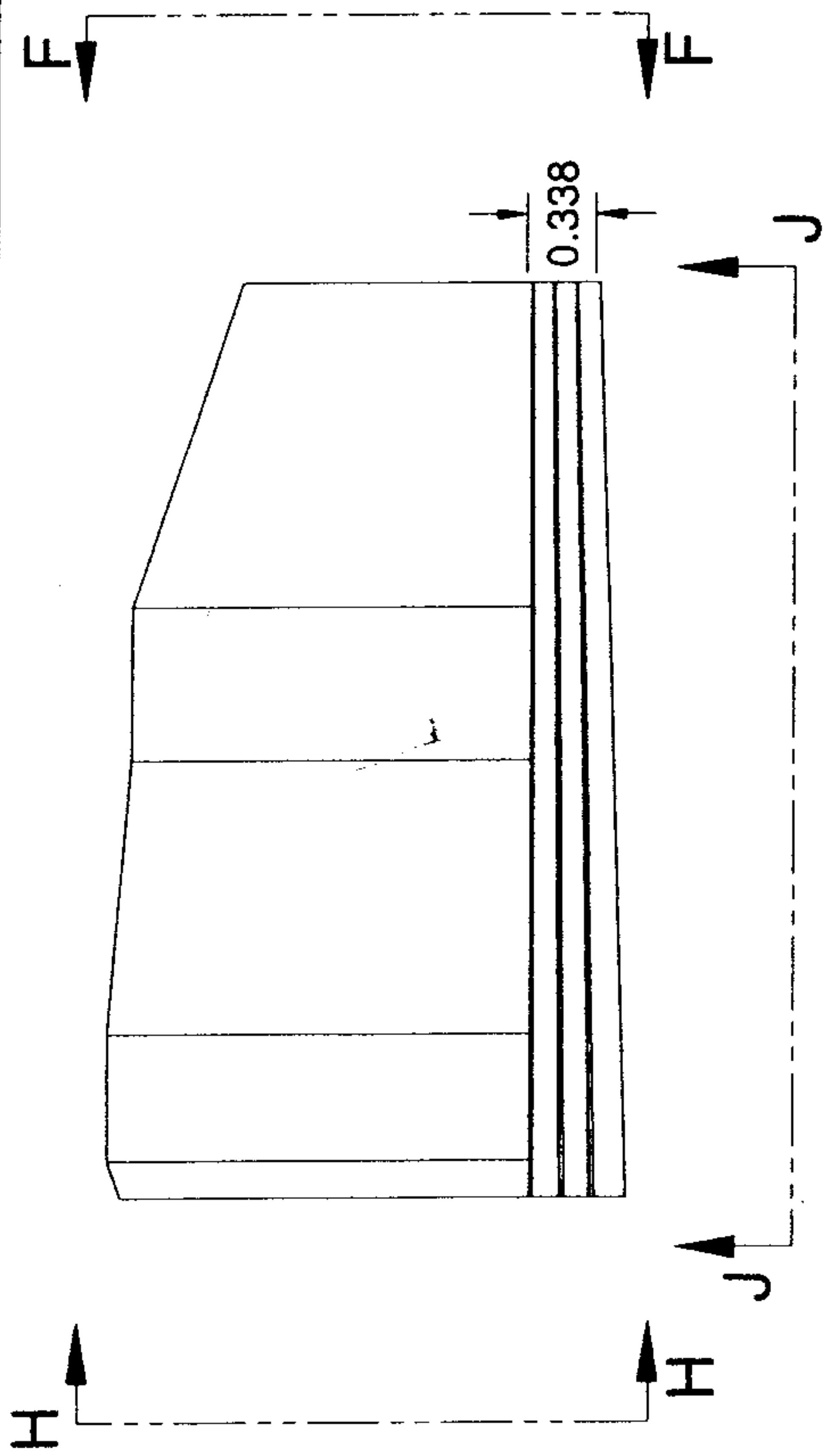

Fig. 16



VIEW J-J
SCALE 1.25 : 1

Fig. 17

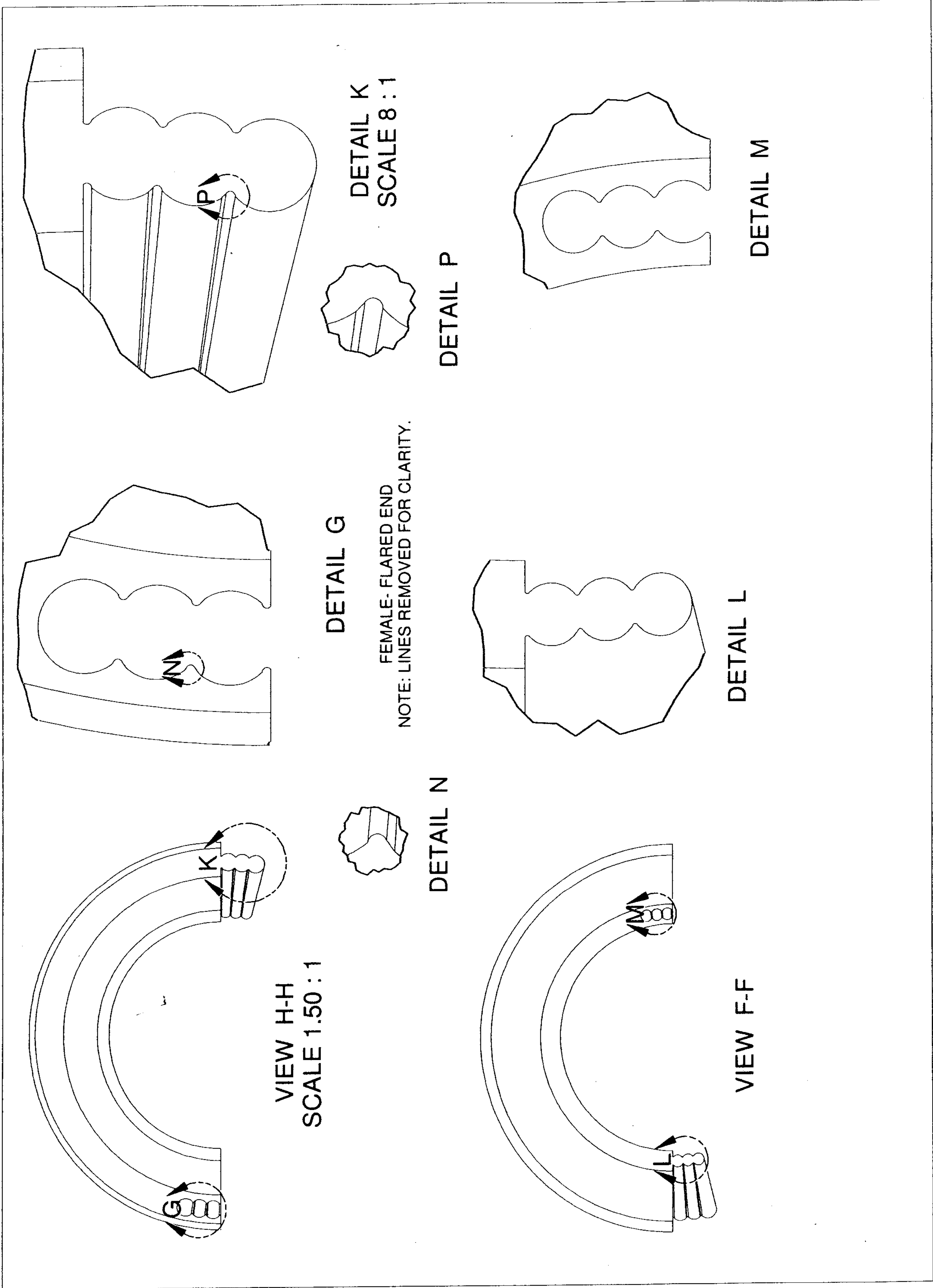
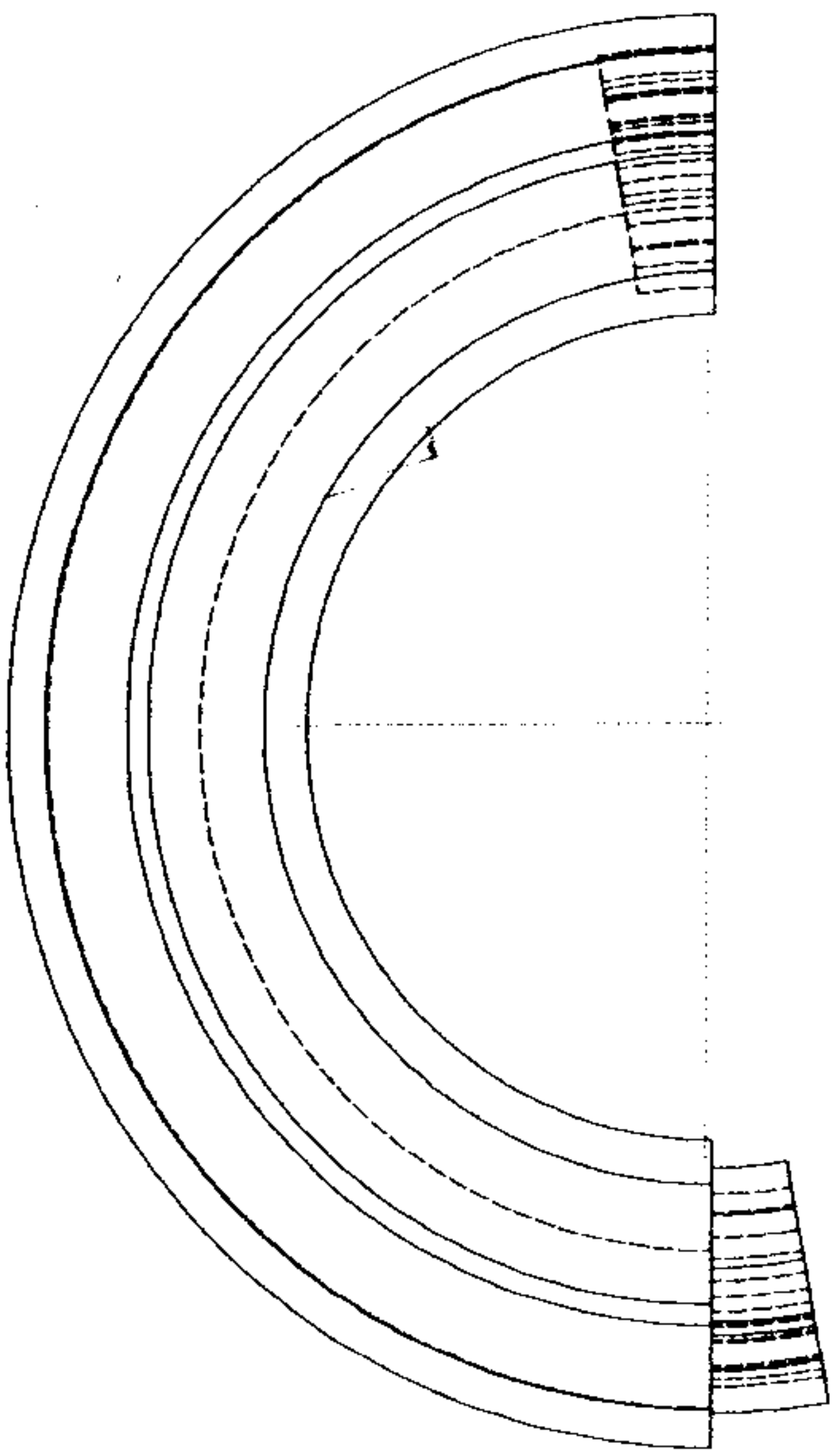
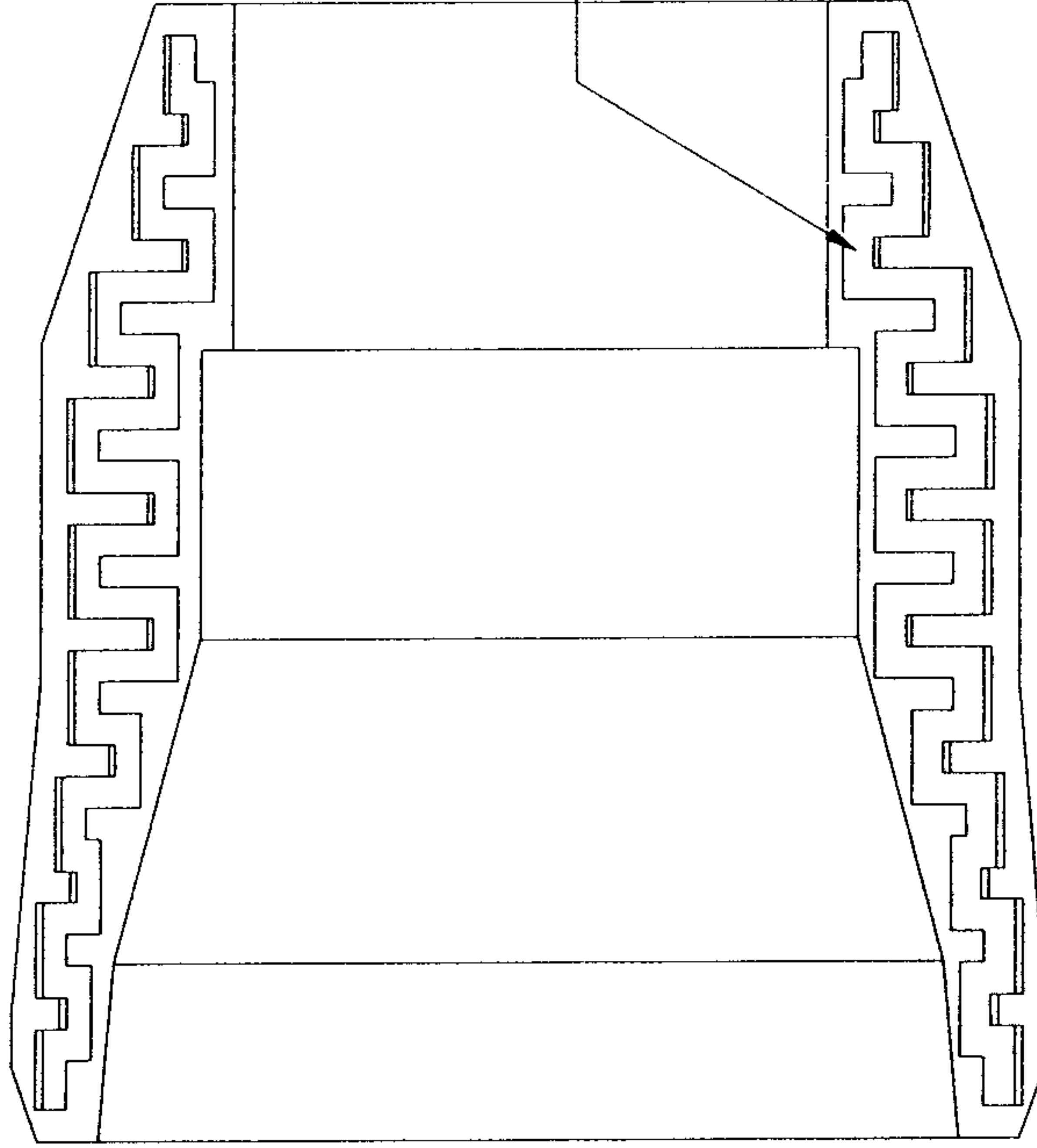
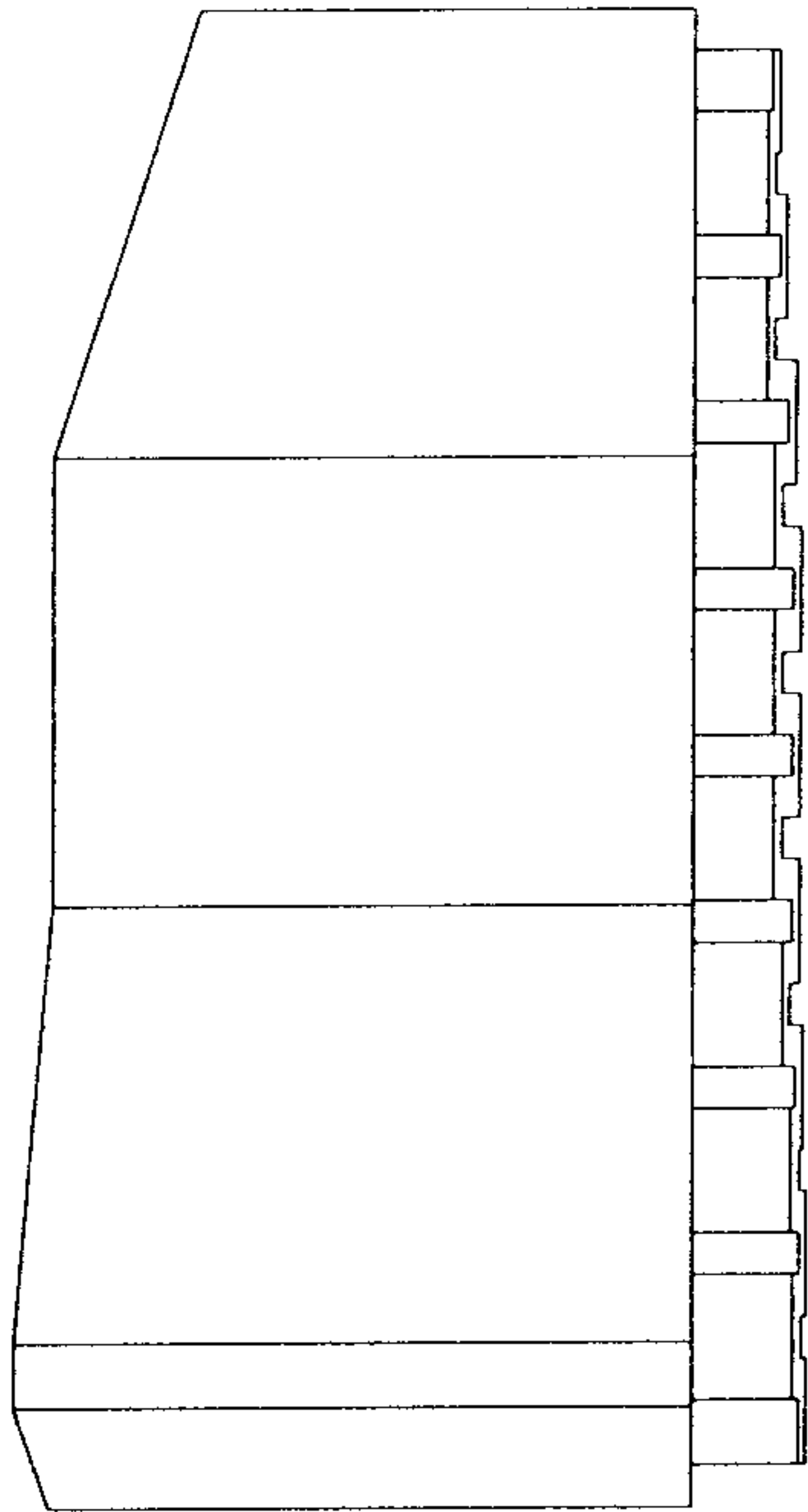

Fig. 18



NOTE: REFER TO STANDARD CUP DIMENSION DRAWING.

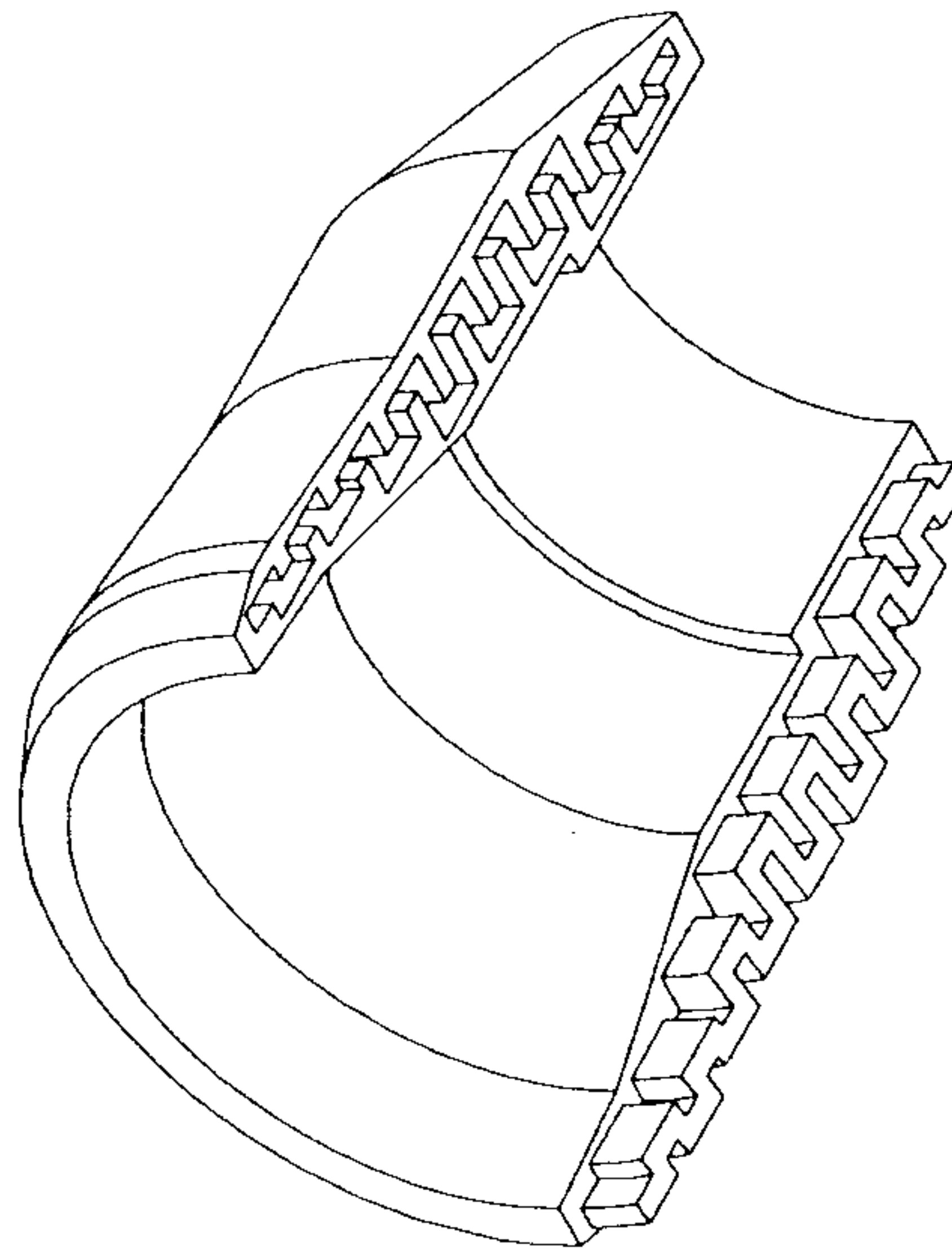

Fig. 19

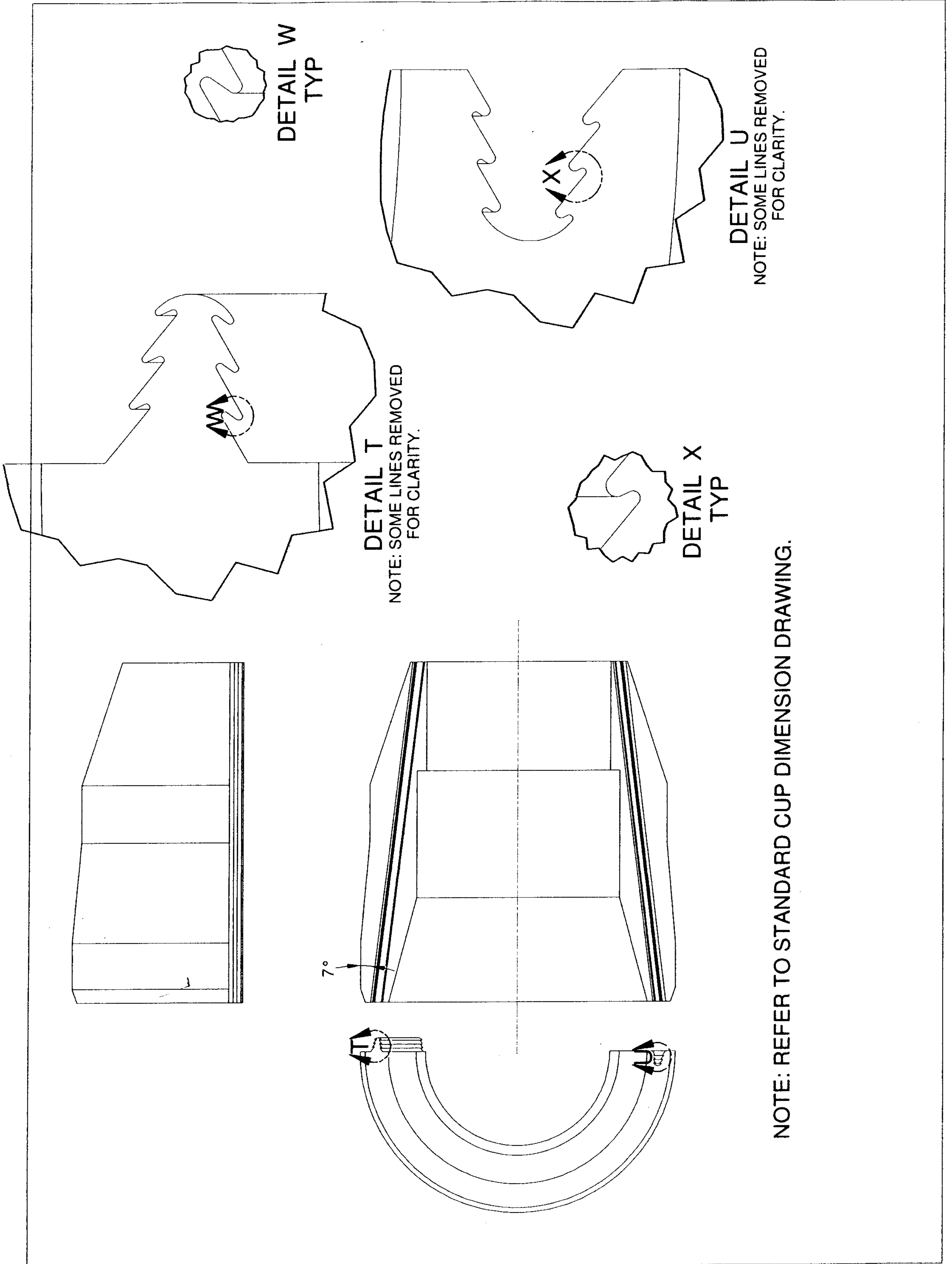
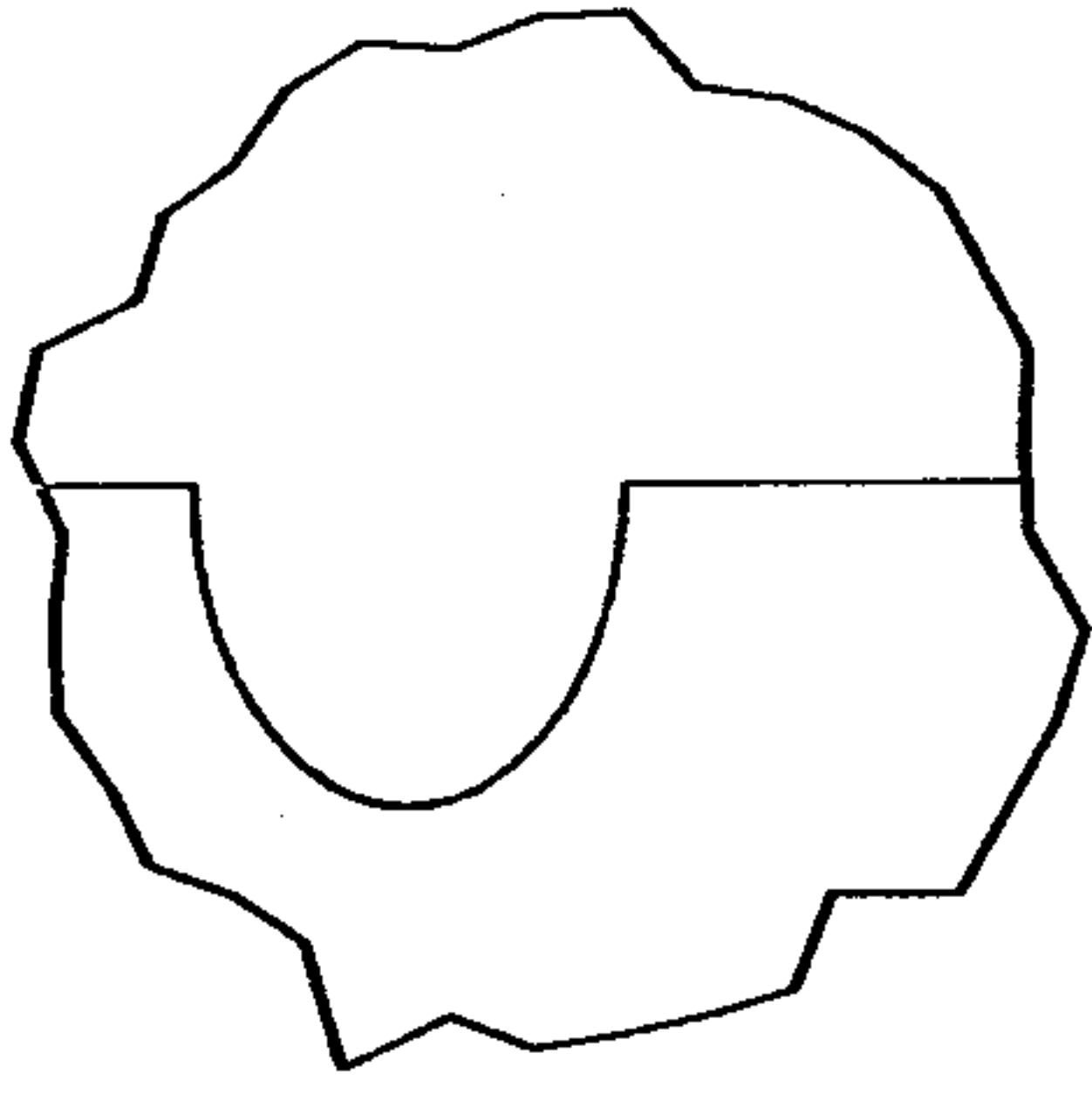
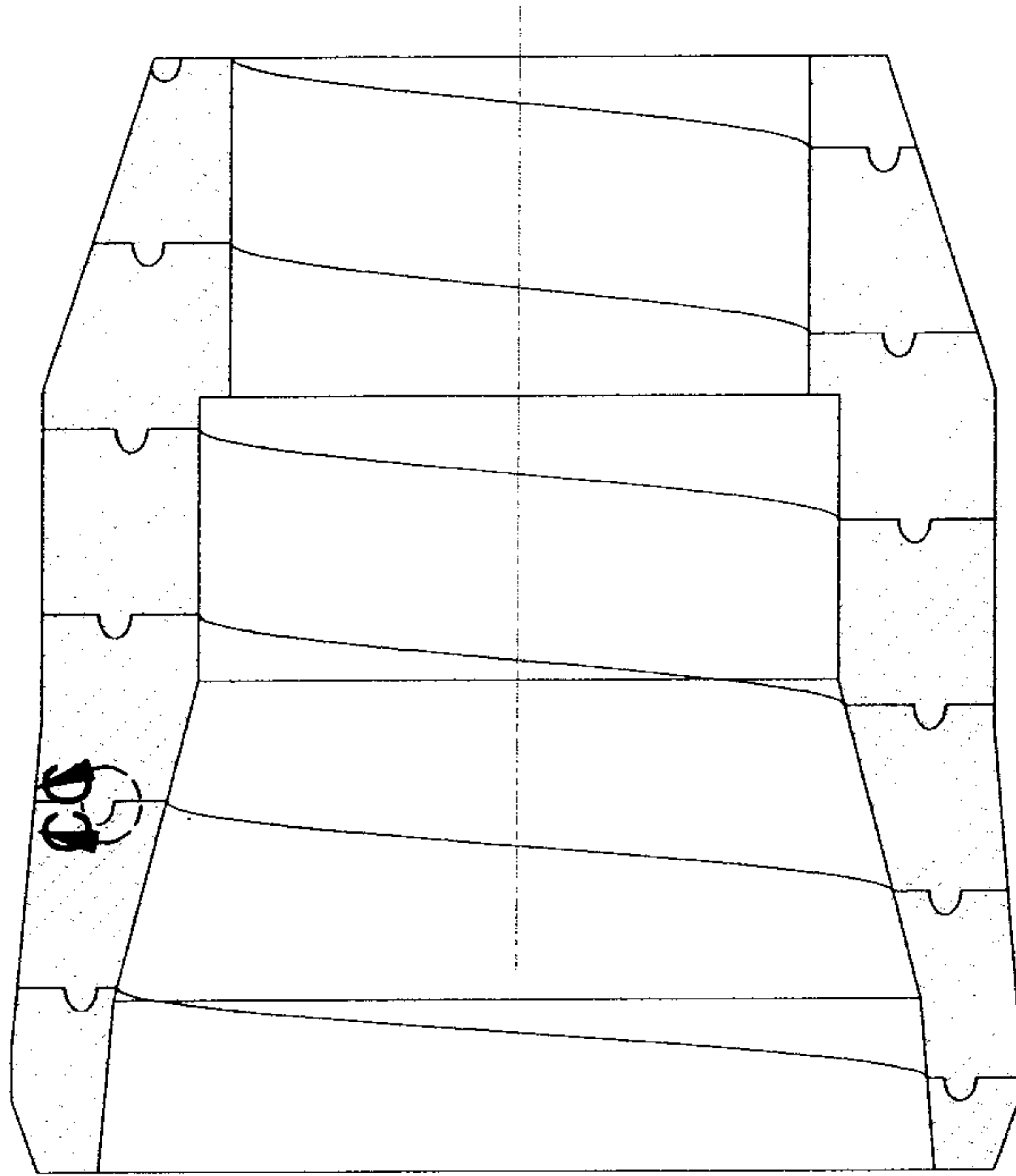

Fig. 20



DETAIL CC

NOTE: CUT COIL PROFILE AS SHOWN BEGINNING FROM EDGE OF WIDE CUP END.
COIL SPECIFICATIONS:
0.75 PITCH
6 REVOLUTIONS
TAPERED AT -5 DEG



SECTION BB-BB

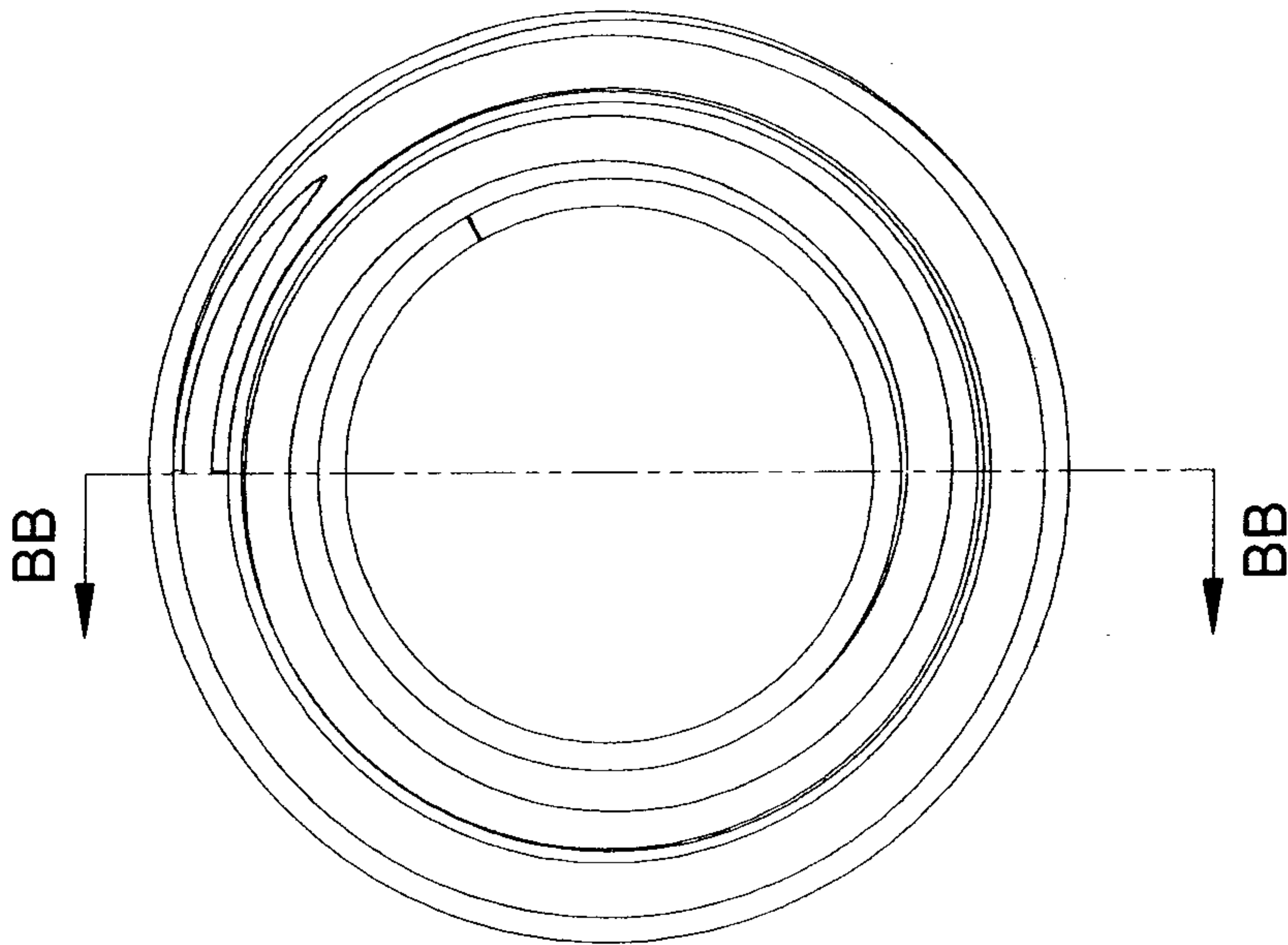

NOTE: SEE GENERAL CUP DIMENSION DRAWING.

Fig. 21

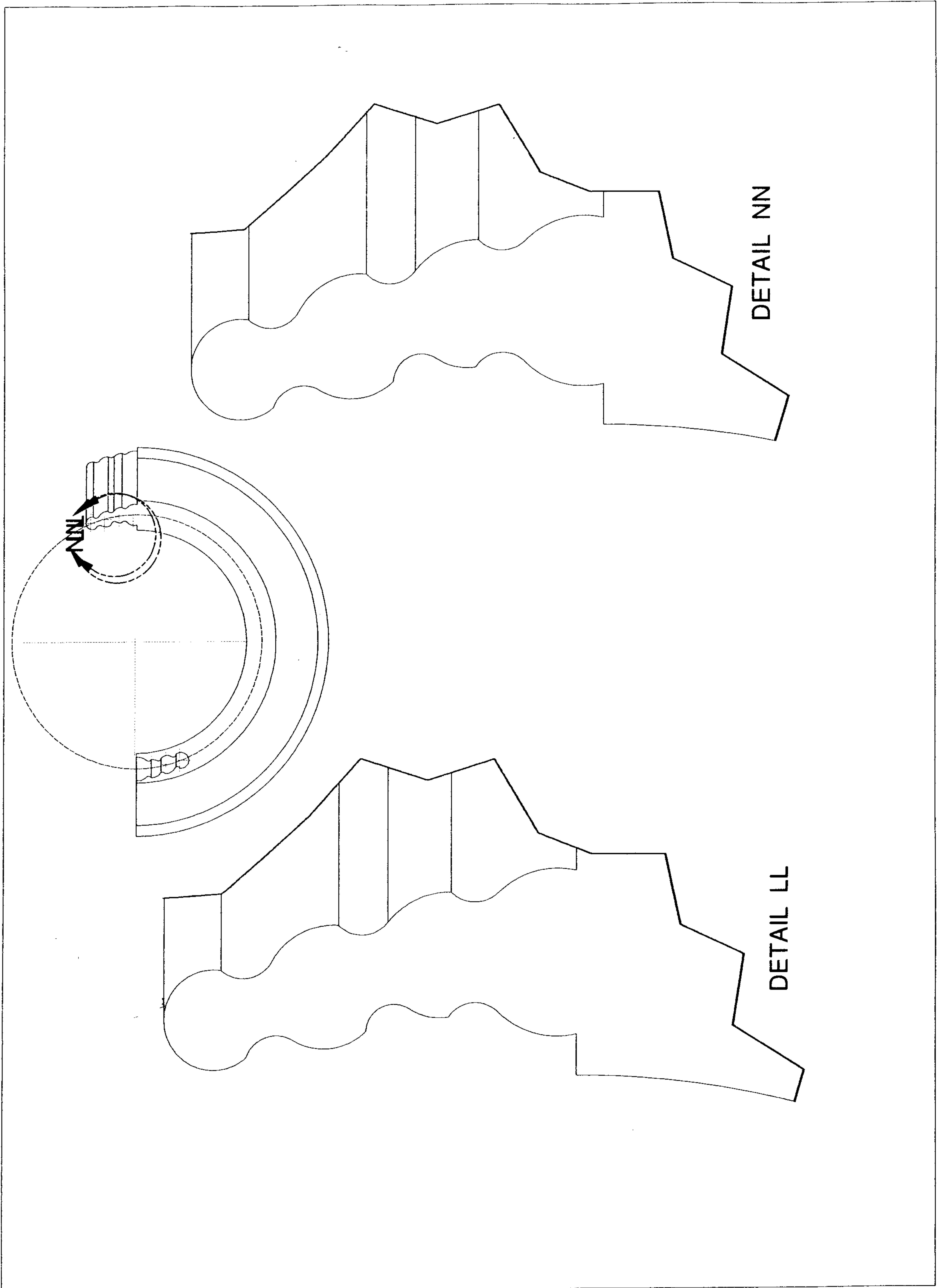

Fig. 22

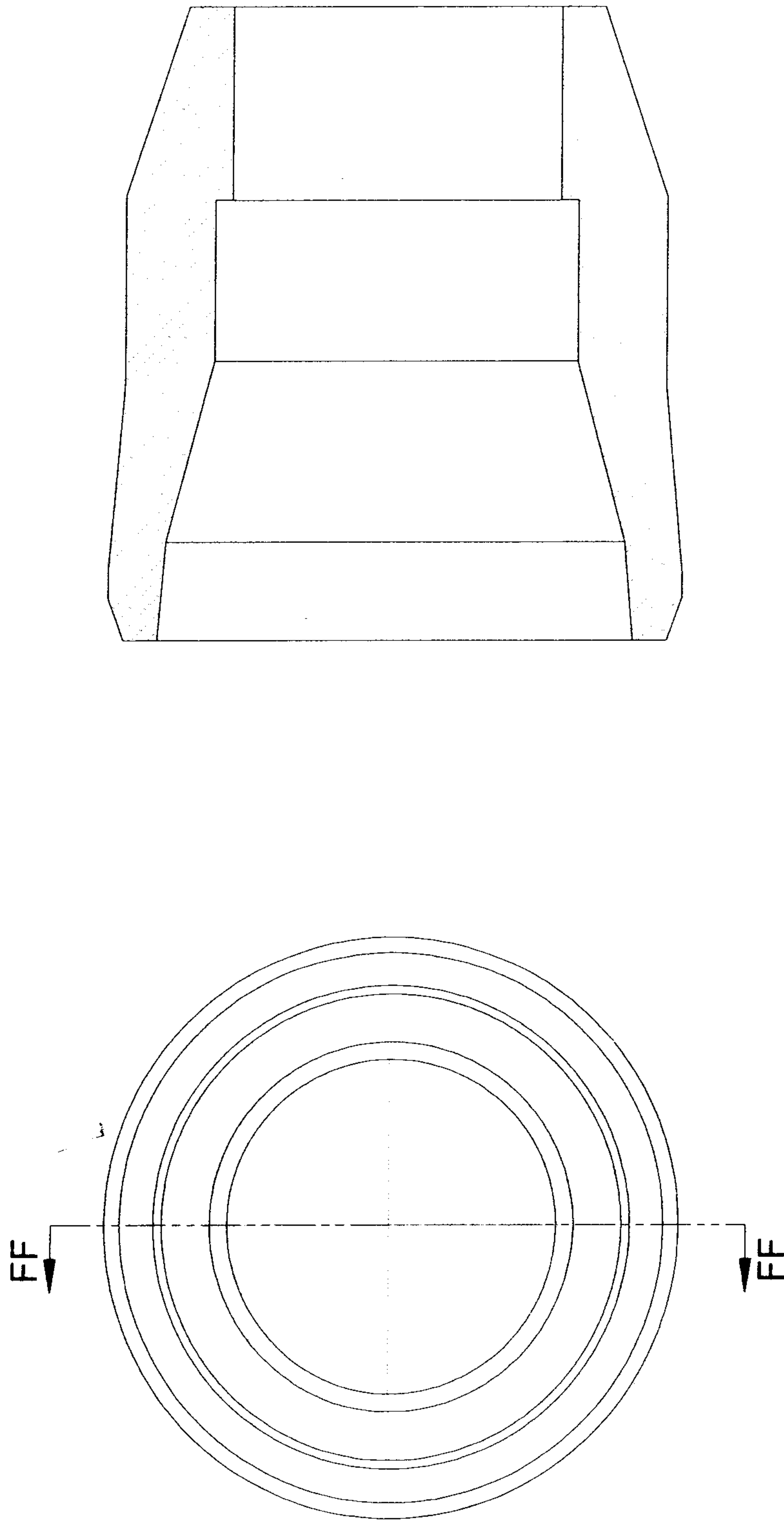

Fig. 23

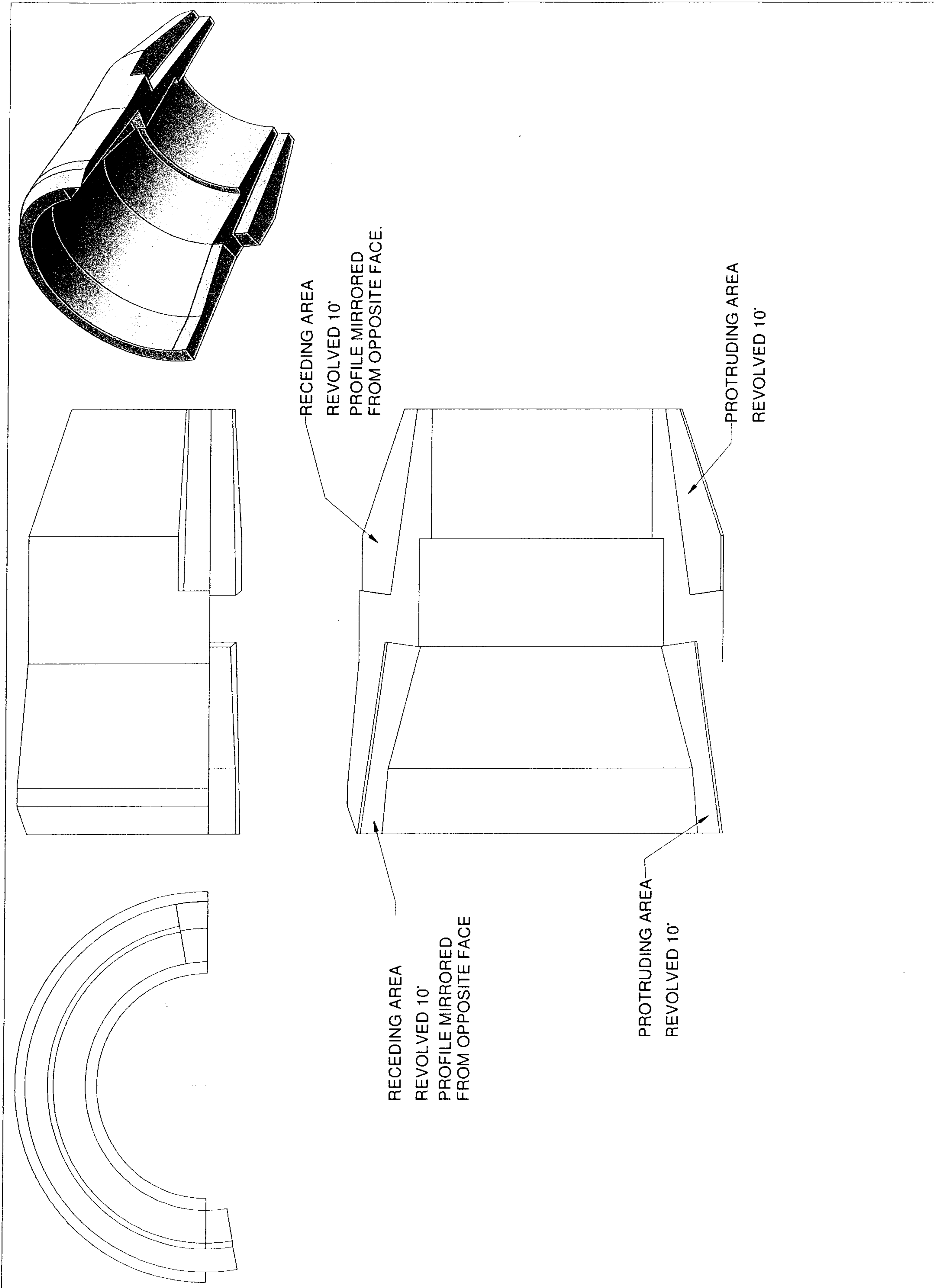

Fig. 24

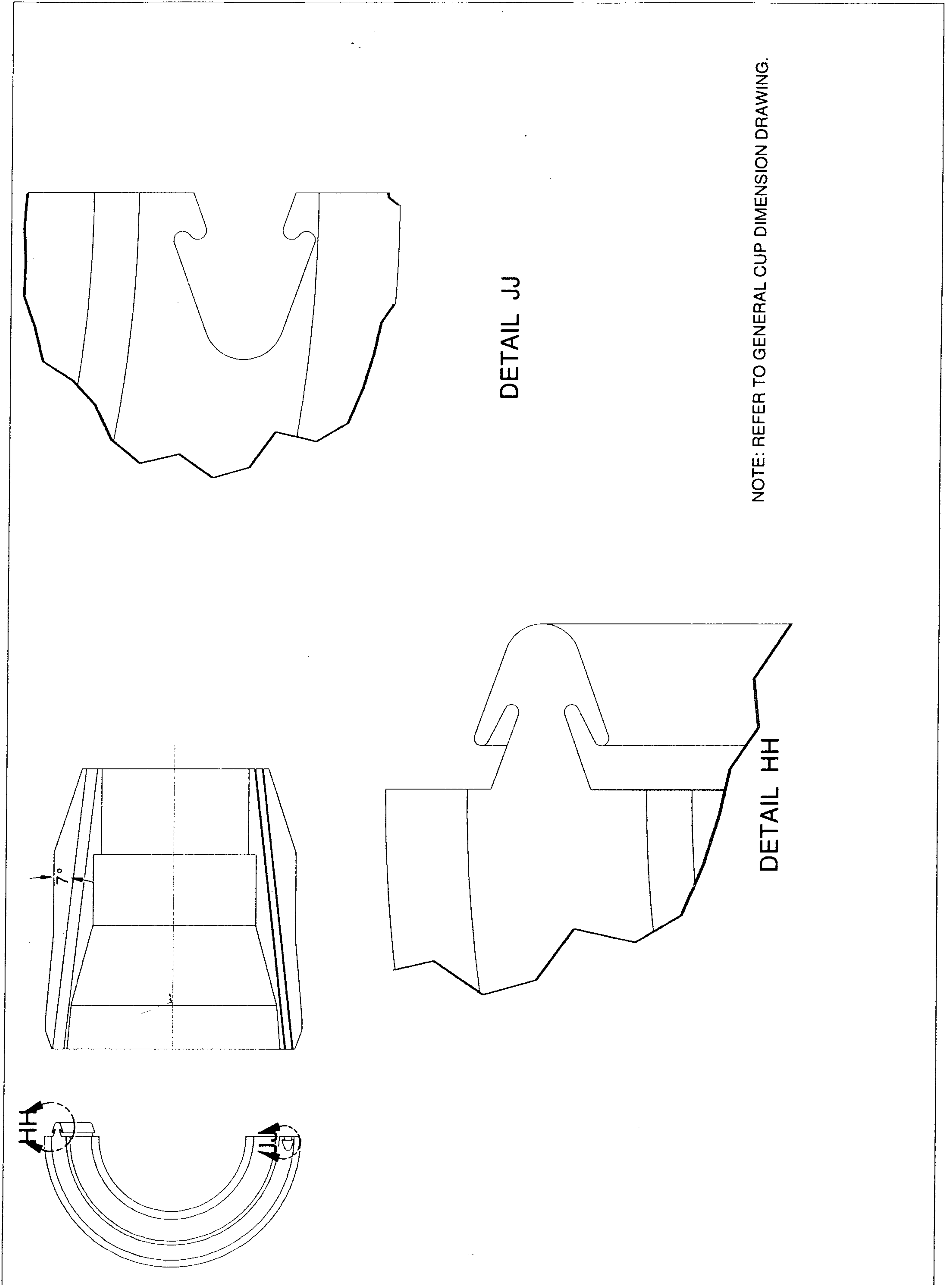

Fig. 25

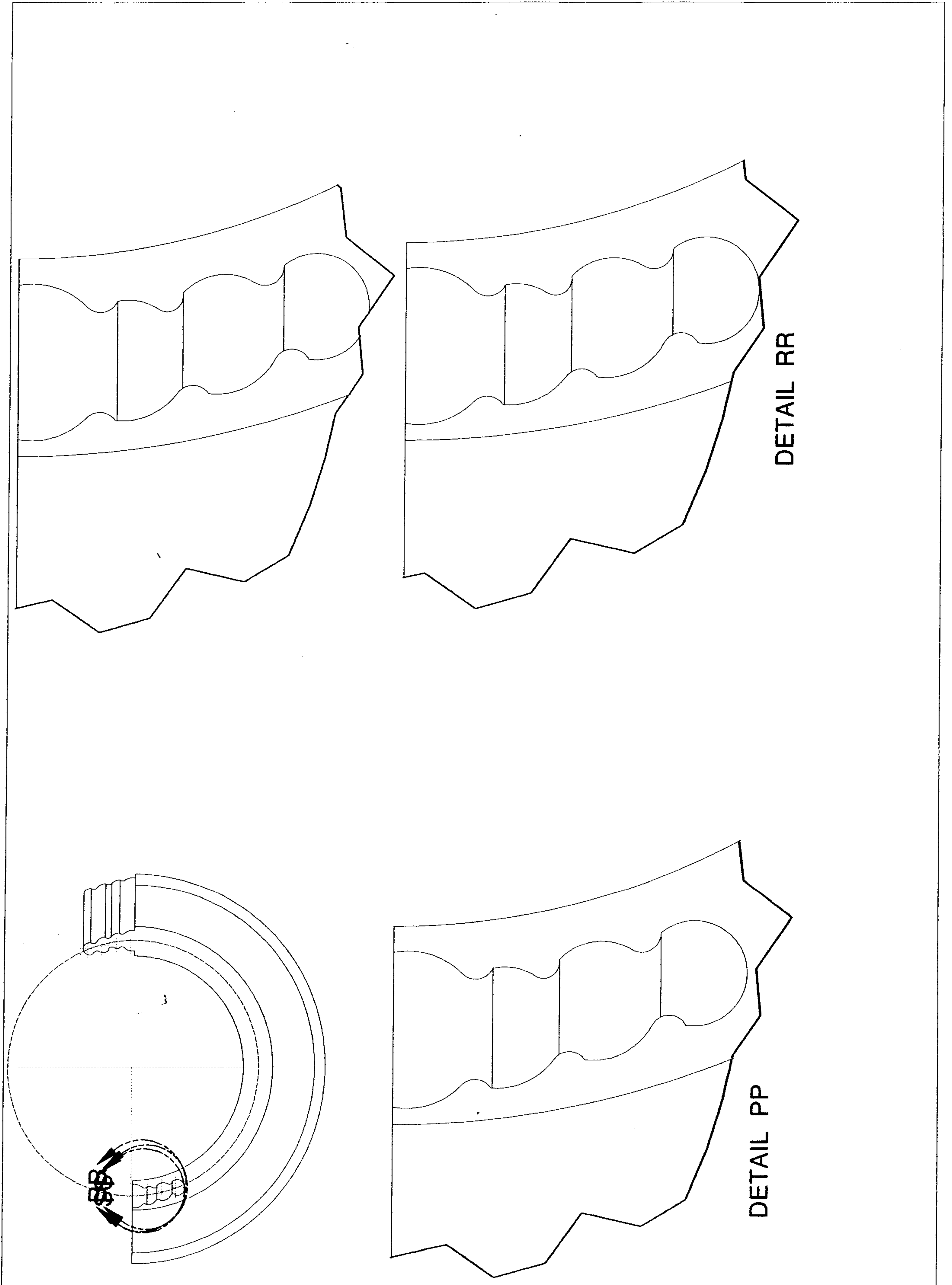
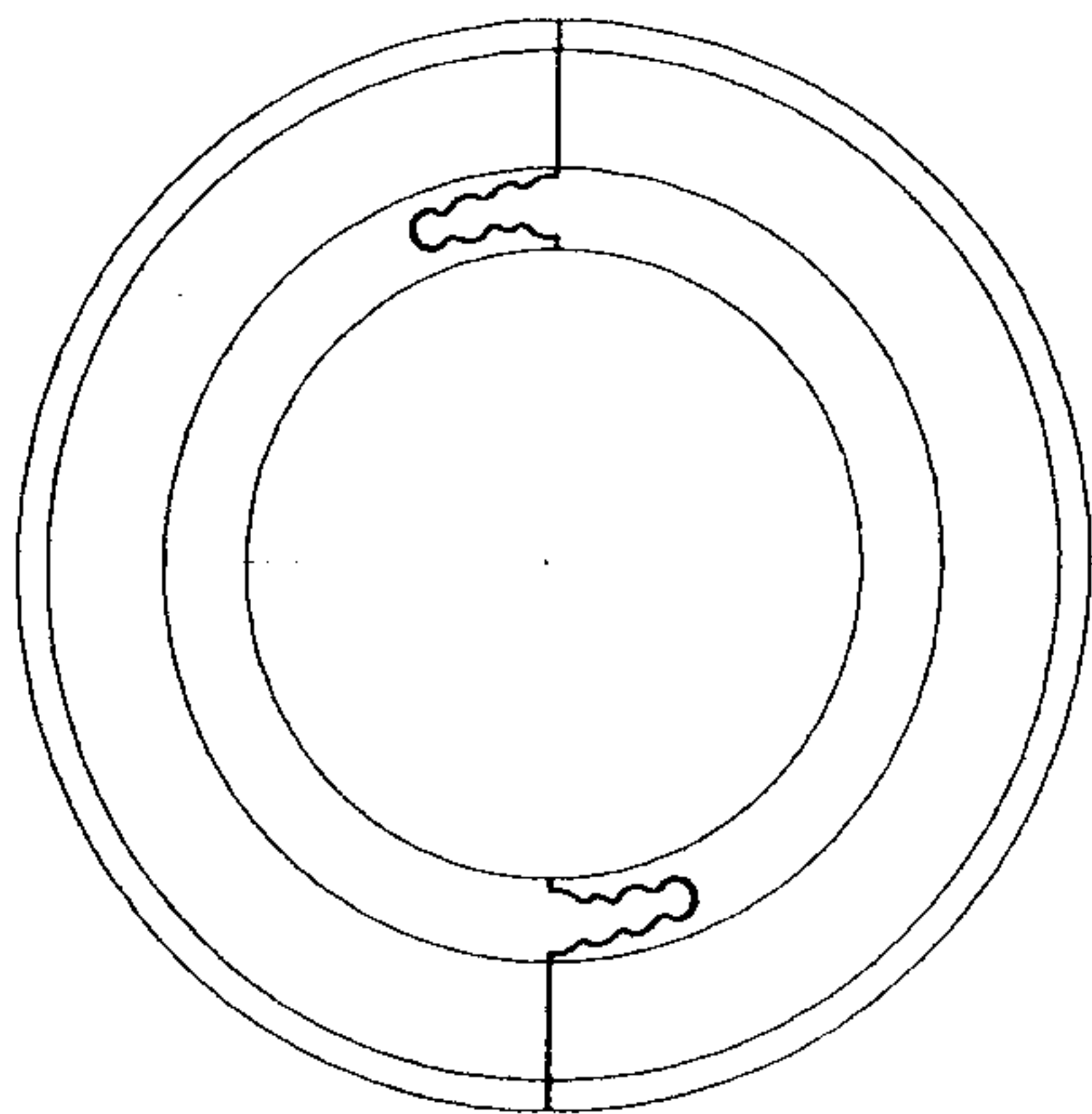
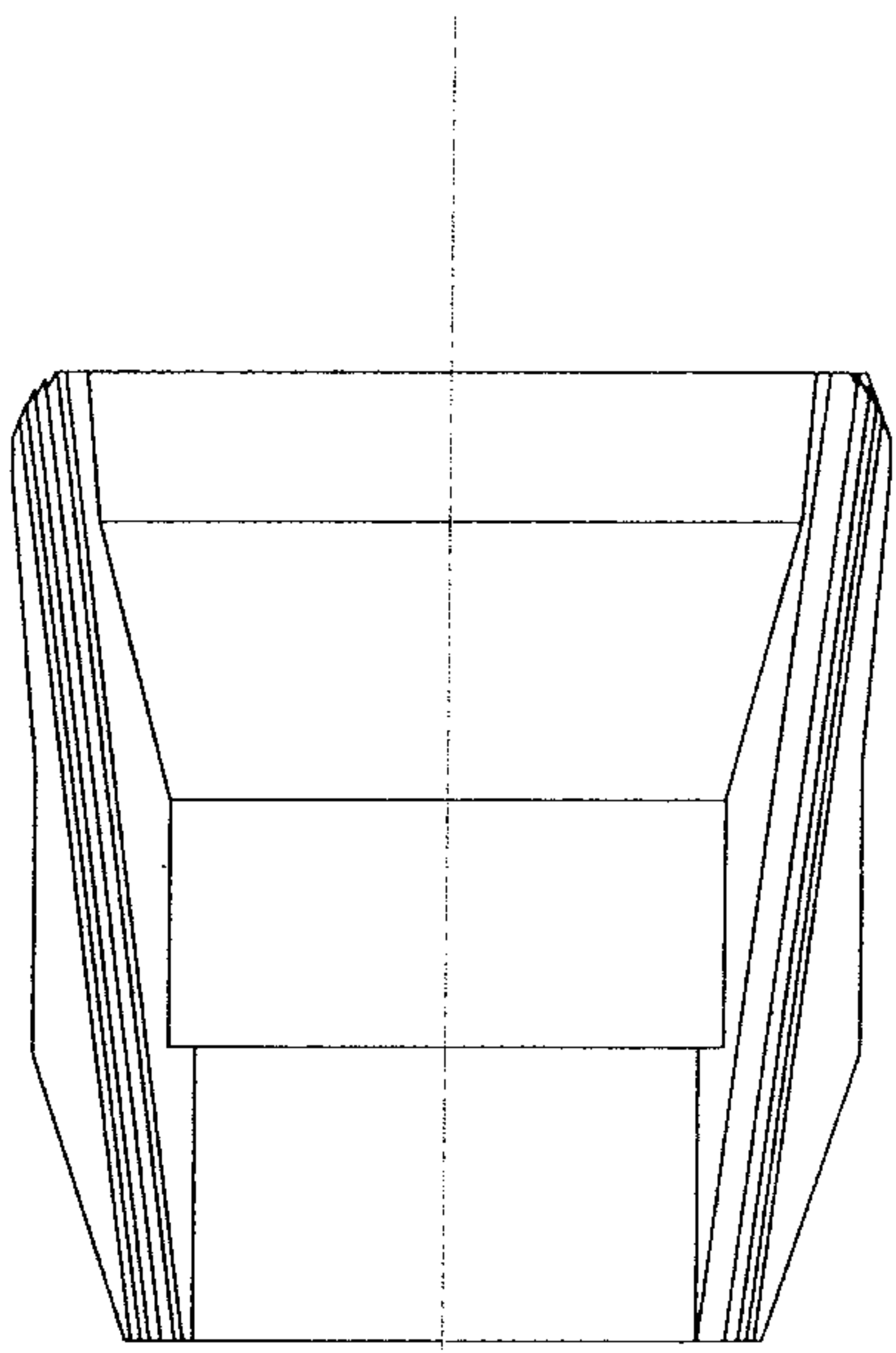
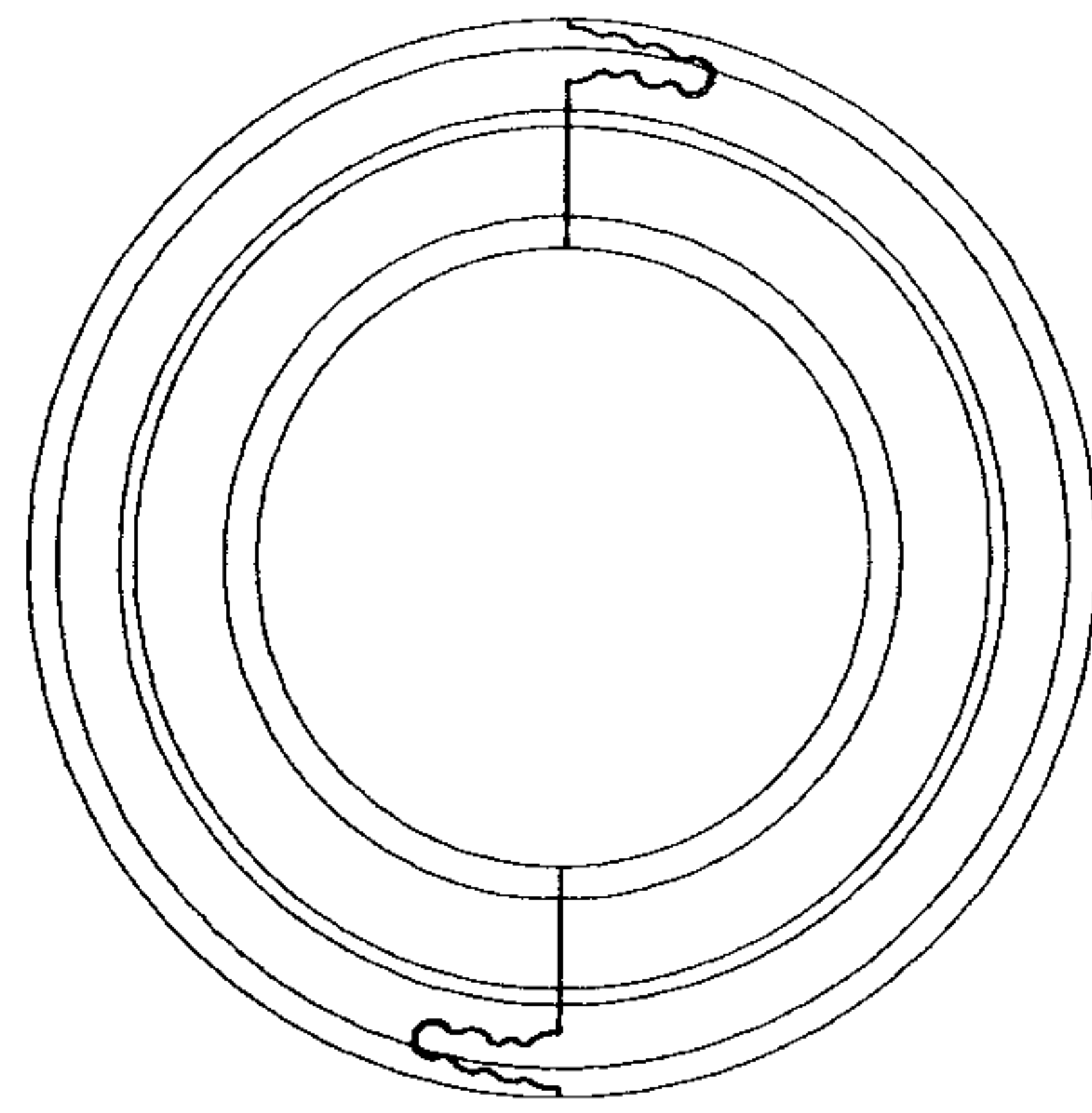
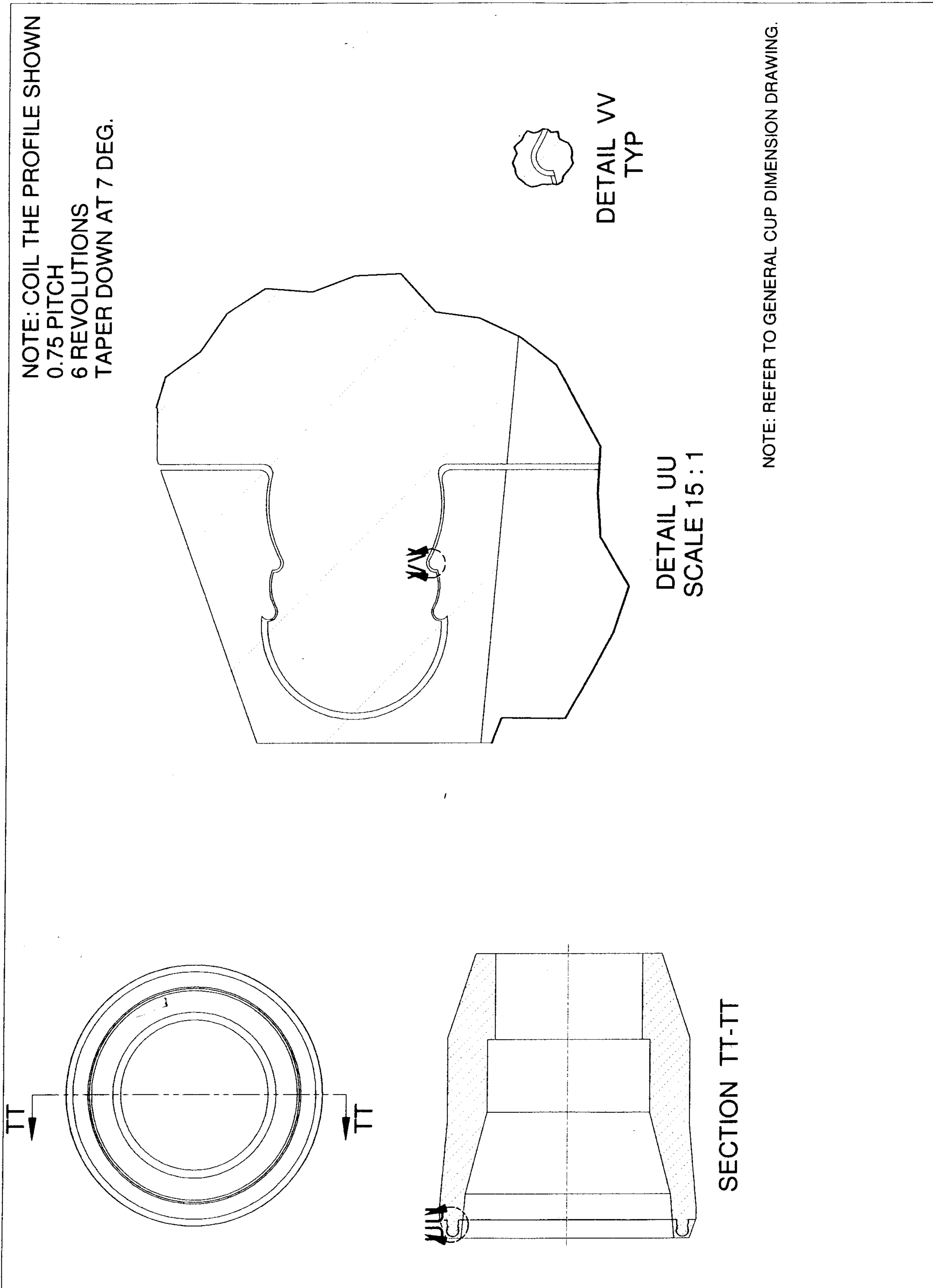

Fig. 26



NOTE: REFER TO GENERAL CUP DIMENSION DRAWING.

Fig. 27



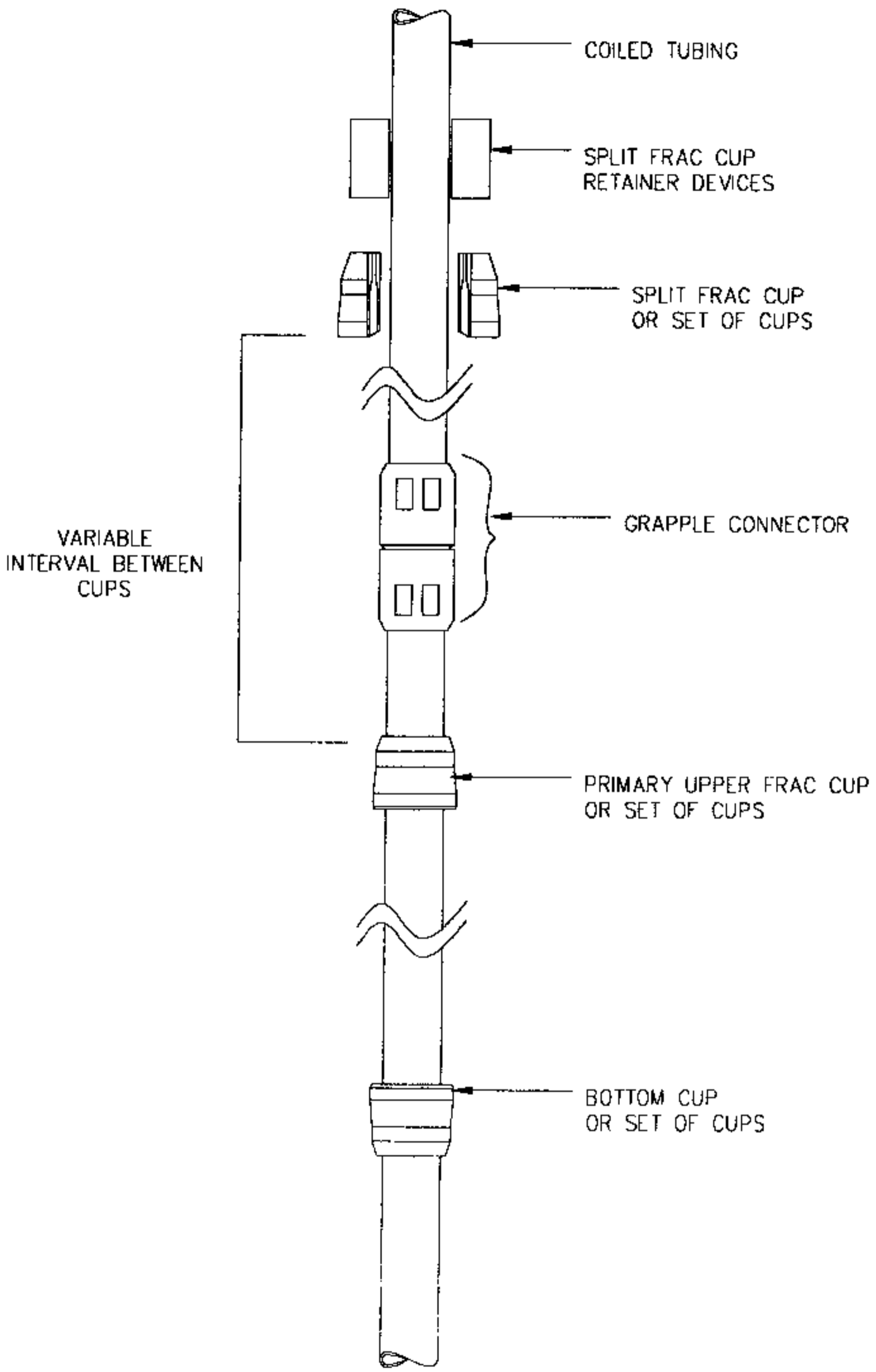

CONFIGURATION WITH SECONDARY UPPER SPLIT CUP