



US 20090041549A1

(19) **United States**

(12) **Patent Application Publication**
Stahm et al.

(10) **Pub. No.: US 2009/0041549 A1**

(43) **Pub. Date: Feb. 12, 2009**

(54) **EARTH ANCHOR**

Related U.S. Application Data

(75) Inventors: **William G. Stahm**, Brighton, CO
(US); **Dennis A. Gross**, Lake
Forest, IL (US)

(63) Continuation-in-part of application No. 11/891,090,
filed on Aug. 10, 2007.

Publication Classification

Correspondence Address:
DENNIS A. GROSS
D/B/A THE HILL FIRM
666 DUNDEE RD, SUITE 1201
NORTHBROOK, IL 60062 (US)

(51) **Int. Cl.**
E02D 5/80 (2006.01)

(52) **U.S. Cl.** **405/259.1**

(57) **ABSTRACT**

An earth anchor of the pivoting type having an essentially cylindrical body, a blind bore extending thereinto from a trailing axial end of the cylindrical body and a leading edge projecting from a leading end of the body, the leading edge being formed as a rounded surface adapted for penetration through reinforcement paths while minimizing severing of the strands of the mat.

(73) Assignee: **Foresight Products, LLC**

(21) Appl. No.: **12/152,261**

(22) Filed: **May 13, 2008**

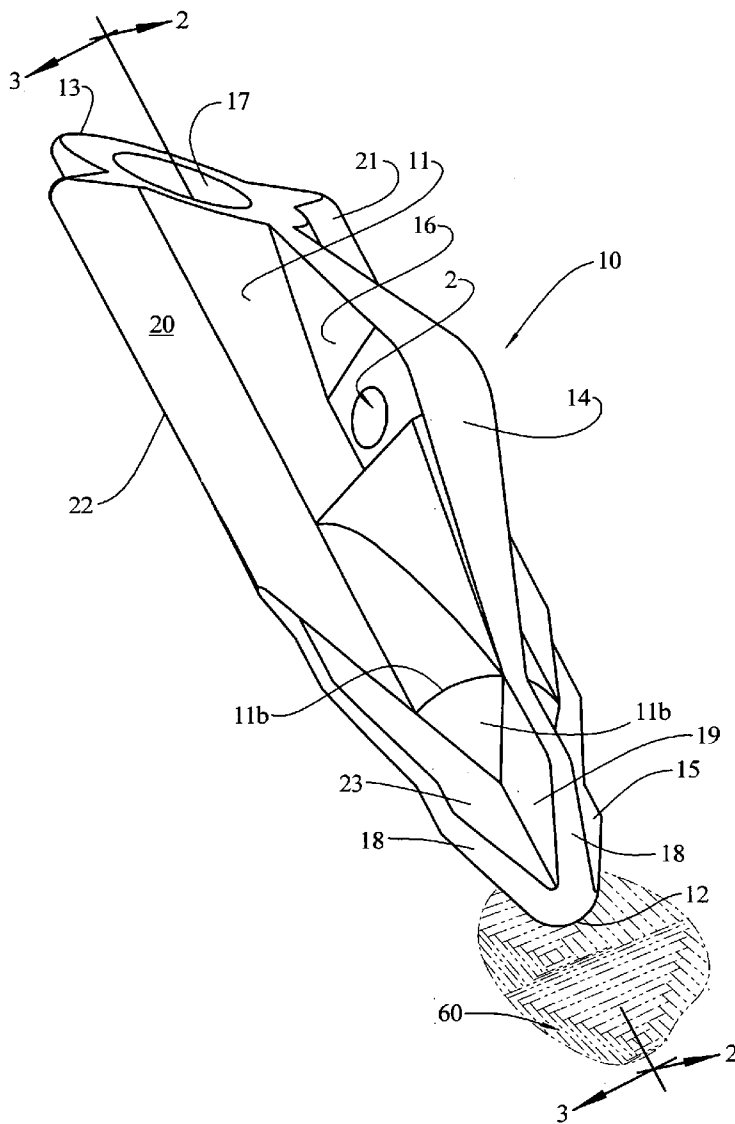

FIG. 1

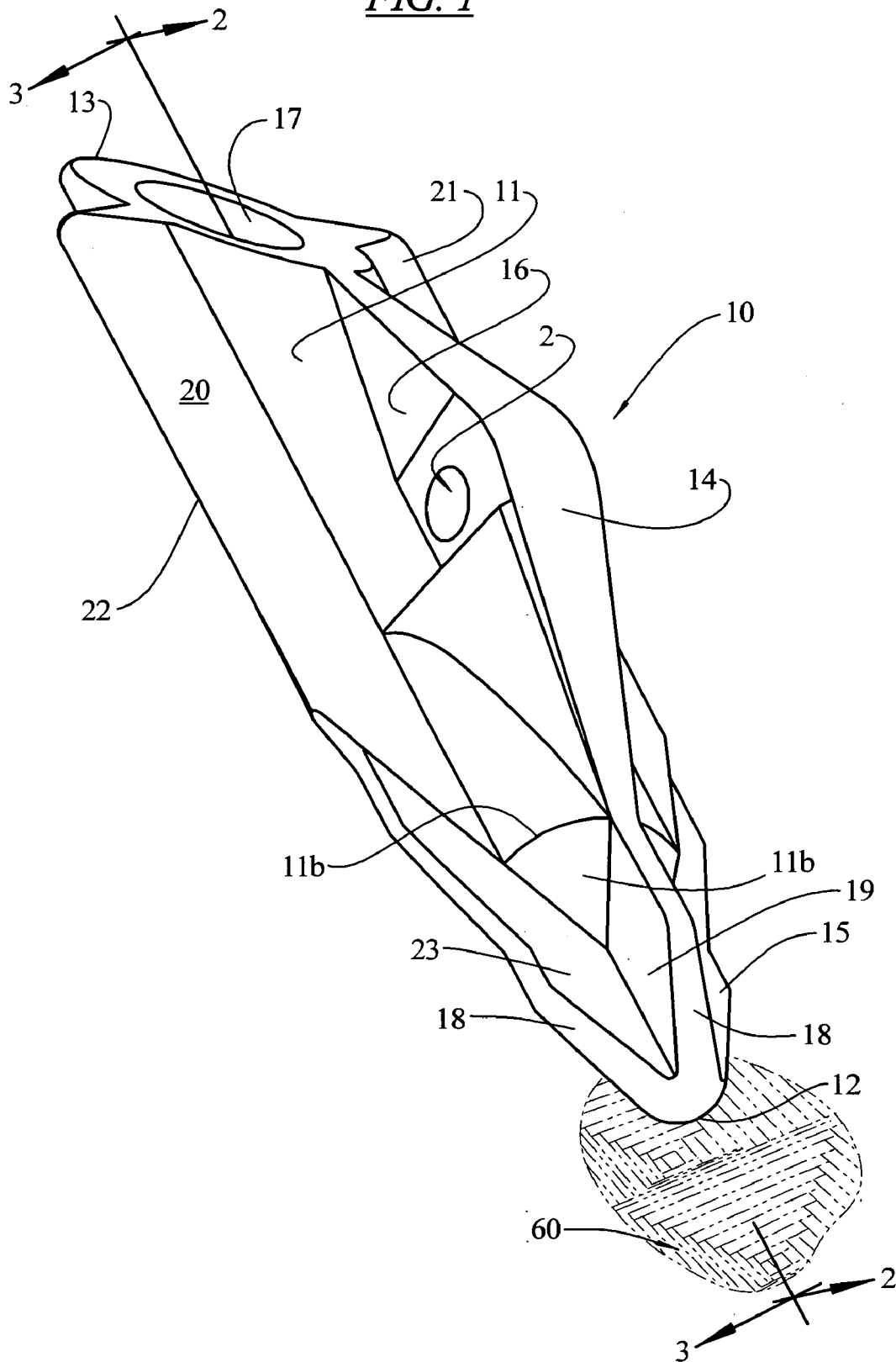

FIG. 2

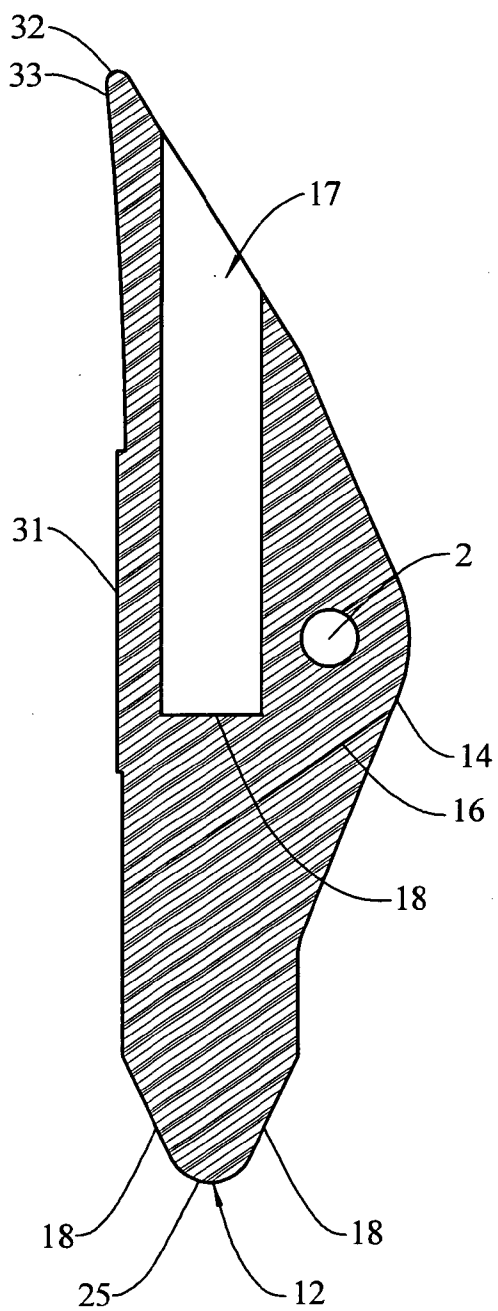
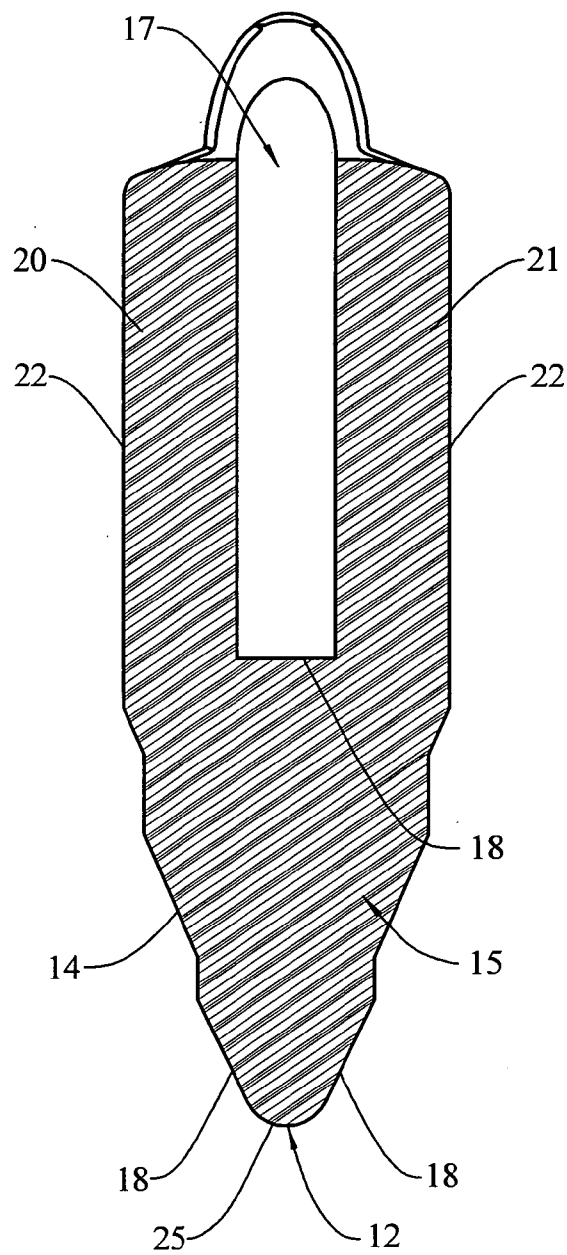
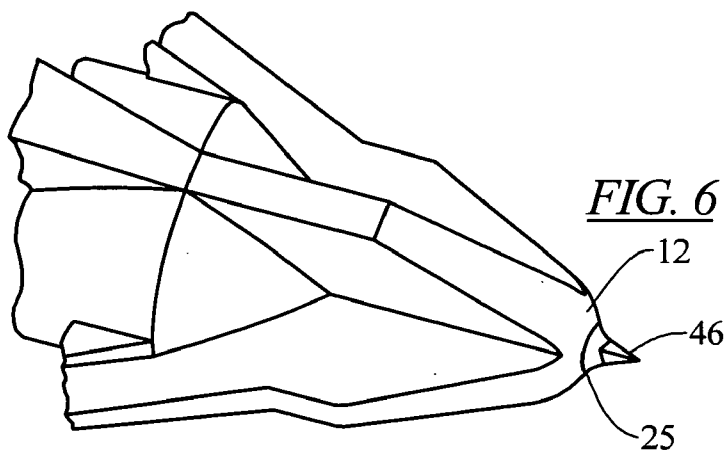
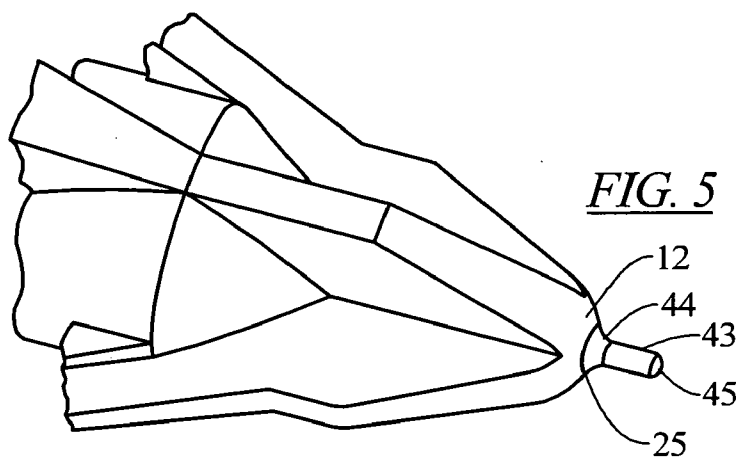
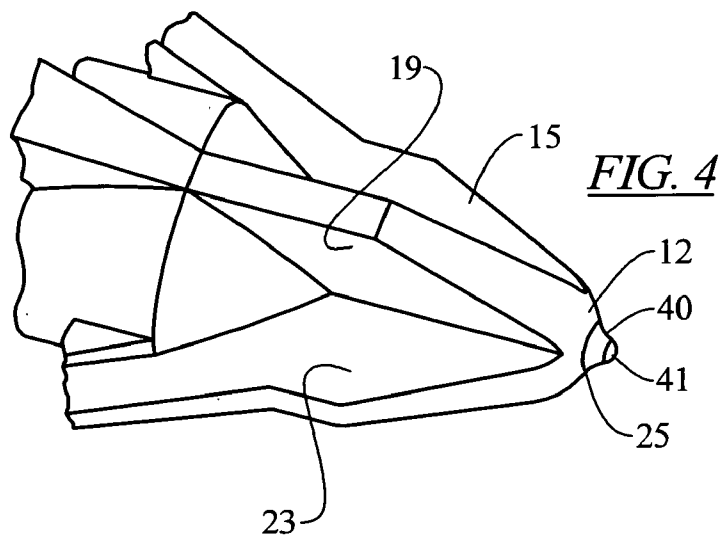

FIG. 3





EARTH ANCHOR

[0001] This application is a continuation-in-part of U.S. patent application Ser. No. 11/891,090 filed Aug. 10, 2007 entitled “Improved Earth Anchor.”

BACKGROUND OF THE INVENTION

[0002] 1. Field of the Invention

[0003] This invention relates to ground anchors, and more specifically to driven pivoting ground anchors.

[0004] 2. General Background

[0005] Ground anchors, or earth anchors, of the driven and pivoting or tilting type are well known and generally include a main body portion having a leading edge adapted to be driven into the ground, a trailing edge including an outturned lip and a cable or rod or guide wire attachment point intermediate the leading and trailing edges generally positioned from about the midpoint of the overall length of the anchor or towards the trailing edge so that upon exertion of the force on the cable or attached rod or guide wire, after insertion of the anchor into the ground, the trailing edge’s outturned lip will bite into the earth, causing the anchor to rotate or pivot to a locked position generally at a right angle to the withdrawal force.

[0006] Widely currently used driven pivoting anchors of the type described are available from the assignee of this application under its Duckbill trademark and generally employ a somewhat cylindrical main body portion having an attachment point intermediate its ends and having at its forward end a plurality of forwardly extending guiding plane surfaces which terminate in chiseled edges. The cylindrical body shaped member, at its trailing end, has a bore extending into the body of the cylindrical member for receipt of a drive rod for driving the anchor into the earth and is provided with an outturned lip on a side of the cylindrical body portion opposite the side having the cable or guide wire attachment point.

[0007] Such anchors are shown, for example, in U.S. Pat. Nos. 4,044,513 and 4,096,673, both of which are assigned to the assignee of this application. Improvements of such anchors are well known and include, for example, applicant’s pending Design application No. 29/270,187 and U.S. Utility application Ser. No. 11/803,138 filed May 14, 2007.

[0008] Other variants of such anchors are sold, for example, by Foresight Products, LLC under trademarks Manta Ray and Stingray and employ extensive side projecting wings that extend backwardly and outwardly from the leading edges to a greater or lesser degree and provide greater resistance to withdrawal of the anchor after the anchor has been driven into the ground and rotated to the point where the wings lie substantially normal to the tension direction of the cable.

[0009] Such anchors, both of the wingless, small-winged and large wing design, have found successful utility in many applications, including use in connection with revetment and soil retaining mats. However, the chiseled or sharpened leading edges which facilitate penetration into the ground can, in certain instances, cause damage to certain types of soil retaining mats which are commonly used in turf reinforcement and ground stabilization. Such mats, often known as High Performance Turf Reinforcement Mat (HPTRM) of the type available under the mark Pyramat from Propex, Inc. or of the type shown, for example, in U.S. Pat. No. 5,616,399 entitled “Geotextile Fabric Woven or a Honeycomb Weave Pattern and

having a Cusped Profile after Heating,” may consist of individual strands essentially woven or overlaid together and formed or fused to provide the mat. The strands are generally manufactured of plastics material. Other fabric-like woven mats utilizing similar or different materials are also known, as are non-woven mats. Where it is desired to anchor such mats to the underlying soil, the use of the previously known driven pivoting anchors can cause damage to the mat, particularly since the chiseled or sharpened leading edges will have a tendency to cut through the material of the mat, thereby weakening the mat.

[0010] It would therefore be an advance in the anchoring field to provide an anchor suitable for use with such turf reinforcement mats, which could be driven through the mat with a reduced likelihood of damage to the mat.

SUMMARY OF THE INVENTION

[0011] The above advances are provided by the current invention by utilizing a driven pivotal anchor where the leading end is provided with a curved or rounded non-sharp leading end and flattened or rounded guiding plane edges.

[0012] In an embodiment of the invention a plurality of ribs or guiding plane leading edges extend forwardly of a generally cylindrical main body portion of the anchor (which may include a raised rib defining the attachment feature for the cable or rod) with each edge being either blunt or rounded and with each edge converging to a common leading end which is generally rounded.

[0013] In an embodiment of the invention the leading edges projecting forward of the generally cylindrical main body portion are circumferentially spaced from one another and formed as the outside surface of ribs or guiding planes with their edges formed blunted or rounded and which converge to a common leading front end, the leading front end being rounded or covered so as to prevent a non sharp leading end.

[0014] In an embodiment of the invention the generally cylindrical body member has four leading edges formed as orthogonal ribs or planes extending forwardly of the generally cylindrical body portion and tapering to a common leading end which is rounded generally in a partial spherical configuration.

[0015] It is therefore an object of the invention to provide a ground anchor having improved utility for use with mat structures having leading edge surfaces having a reduced tendency to damage the mat during driving of the anchor through the mat structure.

[0016] It is a further and more specific object of this invention to provide a driven pivoting anchor having a curved, rounded or ball-like leading end.

[0017] It is an additional object of this invention to provide a driven-pivoting anchor having a curved leading end formed at an apex of at least three leading edges spaced circumferentially apart from one another about a longitudinal axis wherein the curved apex has an axial projection extending axially thereof forwardly of the anchor body, the projection being substantially reduced in cross section with respect to the curved leading end and providing a guide for insertion into a mat in a manner which minimizes damage to the mat.

[0018] It is a further object of this invention to provide a ground anchor of a pivoting type having a leading end, which is curved providing a non sharp or chiseled leading edge and which has projecting axially therefrom a small diameter short nib or guide member to facilitate initial insertion of the anchor into a mat.

[0019] In a further embodiment of the invention the ground anchor is provided with a main body section having a forward end from which projects a plurality of spaced apart ribs, which are spaced from one another circumferentially about a central axis of the forward portion of the anchor and which converge to a curved leading end from which projects axially a relatively small diameter, relatively short post, nib or guide member, which can be introduced into the intersects of the web of a mat to position the anchor to be driven through the mat while causing minimal damage to the mat. The forward projection functions as a leading guide.

[0020] These and other objects will be apparent to those of ordinary skill in the art from a description of the illustrated preferred embodiment, being understood that this is only one such embodiment of this invention and that many variations of shape and dimension are within the scope of this invention. Specifically the generally overall shape of the anchor, the shape of the main central body portion, the shape and extent of the side wings and the number of leading edges or ribs are all modifiable as is generally known to those of ordinary skill in the art and practice in differing commercially available embodiments of driven pivoting anchors.

BRIEF DESCRIPTION OF THE DRAWINGS

[0021] FIG. 1 is a perspective view of the anchor of this invention.

[0022] FIG. 2 is a cross sectional view of the anchor of this invention taken along the lines 2-2 of FIG. 1.

[0023] FIG. 3 is a cross sectional view of the anchor taken along the lines 3-3 of FIG. 1.

[0024] FIG. 4 is an enlarged respective view of the leading end of the anchor of FIG. 1 equipped with a guide nib.

[0025] FIG. 5 is a view similar to FIG. 5 showing a slightly axially longer extending guide nib.

[0026] FIG. 6 is a view similar to FIGS. 5 and 6 showing a guide nib which tapers to a point.

DESCRIPTION OF THE PREFERRED EMBODIMENT

[0027] FIG. 1 illustrates a ground or earth anchor 10 of the type often referred to as a driven and rotating or pivoting anchor in that the anchor is driven into the ground by force and after having being driven to the desired depth, a cable or rod attachment member attached to the anchor is pulled in a direction to withdrawal the anchor from the ground. Because of the design of the anchor and the position of the attachment of the cable or pulling rod to the anchor, the pulling of the anchor by the attachment member causes the anchor to undergo a pivoting or rotation in the ground towards a final position in which the longitudinal axis of the anchor is positioned more towards a position normal to the pulling cable or rod.

[0028] Such anchors often include a main body section 11, which may be generally cylindrically formed (other shapes are known in the art, including rectangular and oval and are included herein), a leading edge 12, a trailing edge 13, a raised section 14 having means 2 for attachment of a cable, shackle, pivot bolt or the like, which may comprise or be attached to the withdrawing force member which causes the anchor to rotate or pivot from its driven position to its final locked position. As shown in FIG. 1, oftentimes the attachment means 2 is merely an opening through a raised rib 16 on one side of the main body portion 11. The opening may receive a

looped crimped cable end or a shackle bracket or the like. Alternative structures are well known such as where the rib-like structure includes attachment means for receipt of the end of a T-shaped rod or other type of swiveling device. An open bore 17 in the trailing edge extends into the main body portion 11 terminating in a blind end 18 which may, as shown in FIGS. 2 and 3, be flat or which may be rounded or otherwise configured. A driving rod extends into the bore 17 and is used to drive the anchor into the earth. The driving rod may simply be impacted by a hammer for smaller anchors or may be driven by a pneumatic or hydraulic reciprocating power driver for larger anchors.

[0029] In the embodiment illustrated the main body portion is generally cylindrical and terminates at a leading end 11a of the main body portion in a frustoconical section 11b and four equally-distanced spaced ribs of which three, 15, 19 and 23 can be seen in FIG. 1, the fourth being on the bottom opposite the rib 19. Each of the ribs has an outer edge surface 18 and the rib surfaces 18 converge towards the leading end 12. The outer edges 18 may be flat or blunt as shown in FIG. 1 or may be outwardly curved but preferably are not provided with a sharp edge. The ribs 15, 19, 23 may have different shapes. The ribs 15 and 23 extending back behind the frustoconical portion 11b and converge into side wings 20 and 21, which also preferably have rounded or non-sharp outer edges 22. The rib 19 has its edge 18 extending back to the leading end of the generally conical section 11a and blending into the top edge surface 14 of the raised rib 16.

[0030] The four ribs, in this embodiment, converge together to a rounded nose 25 at the end 12. Although different shapes can be provided for the nose, a part spherical or partial ball shape is preferred, although a parabolic shape or some other curvature is acceptable, it being important that the leading end 12 not be provided with a sharp edge. By providing a rounded leading edge 12, the anchor is able to be driven through the mat with minimal damage to the stranding of the mat and, in fact, for smaller anchors without severing any of the strands of the mat as the ball-like nose 25 pushes its way between the strands and non-sharp, rounded or blunt edges 18 force the strands apart as the main body portion of the anchor begins to pierce through the mat.

[0031] The side 31 of the anchor opposite the raised rib 16 is provided at its trailing edge 32 with an outturned lip 33 to facilitate pivoting during drawback, as is well known in the art.

[0032] In use the mat schematically shown at 60 is placed in position on the surface to be retained or secured and the ball-like nose of the anchor is placed against the mat surface and is then begun to be driven through the mat. As the ball-like, rounded or curved nose, enters the structure of the mat it will cause the strands of the mat to be pushed aside. As the anchor is driven further into the mat, the degree by which the strands are pushed aside will increase to allow the anchor to pass through the mat. In many instances utilizing normally stranded mats and standard smaller sized anchors equipped with the rounded or ball-like nose leading edge, the entire anchor can be pushed through the mat without breaking the strands of the mat. In other instances when slightly larger anchors are used one or more of the strands may be stretched beyond its limit and separate, but damage to the mat is minimal compared to the use of sharper or chiseled or leading edges or sharper edges extending backwardly from a leading point. While the use of blunted, rounded non-sharpened nose portions and leading side edges on the ribs and along the body

may increase the resistance to driving of the anchor into the ground, when such anchors are used for soil erosion or soil stabilization, they are most often used in connection with looser or less resistant soil conditions such that the disadvantage, which may rise from an increase in resistance to driving in comparison to chiseled edged or sharpened edged anchors is minimized.

[0033] It will therefore be understood from the above that this invention improve upon the prior art driven pivoting anchors by providing an intentionally rounded non-sharp leading nose or leading end which can be pushed through a woven or non-woven retaining mat with minimal damage to the mat.

[0034] FIGS. 4, 5 and 6 illustrate a modified form of the rounded nose ground anchor of this invention. A guide nib or small protrusion 25 has been provided at the apex of the leading edge 12, which is formed at the converging area of the ribs 15, 19, 23, and the fourth rib, if present, on the underside opposite the rib 19. The leading end 12 has its rounded nose 25 provided with an axially extending nib 25, which as shown in FIG. 4 may, for example, be basically conical as at 40, having a rounded tip 41 at the apex of the cone, the cone, as shown, blending outwardly into the rounded end 12 at the nose.

[0035] FIG. 5 shows a nib 43 initially formed similar to the nib 25 having the conical section 44 at the nose 12, however the conical section 44 of FIG. 6 ends in a short rod or cylinder 43 which extends forwardly to a slightly greater distance than the nib 40 of FIG. 5. The section 43 terminates in a rounded end 45.

[0036] FIG. 6 shows yet another form of the nib 25, in this instance having a pyramidal or pointed shape 46 extending outwardly from the nose 12.

[0037] The purpose of the nibs 25 is to provide a leading guide member at the forward most portion of the anchor which is, with respect to the remainder of the anchor, extremely small and which extends only for a short distance from the rounded nose. This guide can be used to help align the anchor during initial setup with the nib inverted into the gap, opening or intersect of the weave of the mat, or in the case of a non-woven mat to a point to position an anchor at a precise point before the anchor begins to be driven through the mat. The smallness of the guide will have essentially almost no effect on the mat and will help align the curved surface of the nose with an appropriate entry point for the anchor into the body of the mat, the anchor in all other respects having the rounded, balled or curved nose of the anchor of FIGS. 1-3.

[0038] Persons of ordinary skill in the art will understand that this invention may be practiced in embodiments other than that illustrated. It is not intended that this invention be limited to the particular anchor shape shown.

I claim as my invention:

1. In a driven pivoting anchor of the type having a leading end to be driven into the ground, an intermediate main body portion and a trailing end adapted to receive a driving instrument for applying a longitudinal driving force to the anchor, the anchor having an attachment point for attaching a withdrawal member, the improvement of the leading end being

rounded and provided with an axially extending small diameter guide nib projecting from the leading end.

2. The anchor of claim 1 wherein the leading end is generally semi-spherical.

3. The anchor of claim 1 wherein the leading end is generally parabolic.

4. The anchor of claim 1 wherein a plurality of ribs extends forward of the main body portion to the leading end, the ribs having generally planer opposite sides and outer edges, the outer edges converging towards one another to the leading edge, and the outer edges being rounded or flat.

5. A driven pivoting anchor comprising a main body portion, a leading edge and a trailing edge, with a blind bore extending into the main body portion from the trailing edge, a raised rib or section on the main body portion having an attachment point for attachment of a withdrawal member, with a plurality of rib-like members extending from the main body member to the leading edge the leading edge comprising a rounded surface and the rib members having outer edge surfaces converging to the leading edge, the outer edge surfaces being generally blunted, the leading edge having a small projecting nib extending axially therefrom.

6. The anchor of claim 5 wherein four ribs are provided spaced equal distantly apart, two of the ribs extending backwardly from the leading edge beyond a forward portion of the main body portion and blending into side wings formed alongside the main body portion.

7. The method of securing a stranded soil retention mat to the soil, which comprises the steps of providing a driven and pivoting anchor having a non-sharp, curved leading edge having a protruding nib extending axially from the rounded edge, the nib being small in diameter and acting as a guide, positioning mat having openings therein on the surface of the soil to be retained, positioning the leading edge of the anchor against the mat with the nib end positioned in an opening in the mat, driving the anchor into the mat spreading the strands of the mat apart, continuing the driving of the anchor to a predetermined depth in the soil with an attachment member attached to the anchor and extending through the mat to a point opposite the mat from the driven anchor, causing rotation of the anchor by pulling on the attachment member and thereafter securing the mat to the attachment member.

8. The method of claim 7 wherein the anchor has a generally part ball-shaped leading portion defined by converging rounded rib outer edges extending forward of the main body portion of the anchor, the outer edges being blunted or curved.

9. The anchor of claim 4 wherein the outer edges curve towards one another as they converge to the leading edge, the curvature providing a rounded leading edge.

10. The anchor of claim 9 wherein the rounded leading edge is generally part spherically shaped in the areas formed by the edges of the ribs.

11. The anchor of claim 1 wherein the projecting nib is substantially conical blending into the forward edge of the leading end.

12. The anchor of claim 1 wherein the nib has a cylindrical extension extending axially forward leading end and terminating in a curved forward surface.

13. The anchor of claim 1 wherein the nib is pointed.

* * * * *