



US00D728633S

(12) **United States Design Patent**
Klassen et al.

(10) **Patent No.:** **US D728,633 S**

(45) **Date of Patent:** **** May 5, 2015**

- (54) **FUEL TANK AND RELATED ASSEMBLY**
- (71) Applicant: **CNH America LLC**, New Holland, PA (US)
- (72) Inventors: **Mark Klassen**, Lockport, IL (US); **Larry Wilson**, Racine, WI (US); **Thomas Chlystek**, Darien, IL (US); **Phetsamone Siriphong**, South Elgin, IL (US); **Michael Bunnell**, Clarendon Hills, IL (US); **Carl Fletcher**, Naperville, IL (US); **John Schrepferman**, South Elgin, IL (US); **Neil Zimmerman**, Kenosha, WI (US)

D484,893 S * 1/2004 Hsiao D15/9
 D488,757 S * 4/2004 Gough D12/196
 D537,450 S * 2/2007 Fretwell D15/4

(Continued)

Primary Examiner — Mark Goodwin
(74) *Attorney, Agent, or Firm* — Sue C. Watson

(57) **CLAIM**
The ornamental design for a fuel tank and related assembly, as shown and described.

DESCRIPTION

FIG. 1 is a perspective view of the fuel tank according to one aspect of the present invention.
 FIG. 2 is a front view of the fuel tank illustrated in FIG. 1.
 FIG. 3 is a rear view of the fuel tank illustrated in FIG. 1.
 FIG. 4 is a side view of the fuel tank illustrated in FIG. 1.
 FIG. 5 is another side view of the fuel tank illustrated in FIG. 1.
 FIG. 6 is a top view of the fuel tank illustrated in FIG. 1.
 FIG. 7 is a bottom view of the fuel tank illustrated in FIG. 1.
 FIG. 8 is a perspective view of a fuel tank assembly according to another aspect of the present invention, the fuel tank assembly including the fuel tank illustrated in FIGS. 1-8.
 FIG. 9 is a front view of the fuel tank assembly illustrated in FIG. 8.
 FIG. 10 is a rear view of the fuel tank assembly illustrated in FIG. 8.
 FIG. 11 is a side view of the fuel tank assembly illustrated in FIG. 8.
 FIG. 12 is another side view of the fuel tank assembly illustrated in FIG. 8.
 FIG. 13 is a top view of the fuel tank assembly illustrated in FIG. 8; and,
 FIG. 14 is a bottom view of the fuel tank assembly illustrated in FIG. 8.
 The surface shading and broken lines shown in FIGS. 1-14 represent portions of the fuel tank and related assembly that form no part of the claimed design.

- (73) Assignee: **CNH Industrial America LLC**, New Holland, PA (US)
- (**) Term: **14 Years**
- (21) Appl. No.: **29/460,638**
- (22) Filed: **Jul. 12, 2013**
- (51) **LOC (10) Cl.** **15-03**
- (52) **U.S. Cl.**
USPC **D15/28**; D12/218
- (58) **Field of Classification Search**
USPC D15/1, 3, 5, 17, 28; D12/218; D23/202;
220/564, 524, 555, 567.2; 280/830,
280/833-835; 180/314, 69.4, 69.5, 900,
180/225; 123/518-520
See application file for complete search history.

(56) **References Cited**

U.S. PATENT DOCUMENTS

4,480,845 A * 11/1984 Hansen 280/834
 D433,425 S * 11/2000 SurrIDGE et al. D15/17
 D435,503 S * 12/2000 Gukeisen et al. D12/218
 D441,710 S * 5/2001 Moehle et al. D12/218

1 Claim, 14 Drawing Sheets

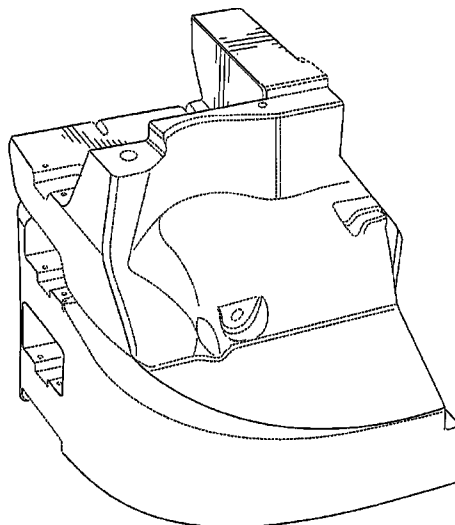

(56)

References Cited

U.S. PATENT DOCUMENTS

D551,153 S *	9/2007	Oury	D12/218	D644,161 S *	8/2011	Fries et al.	D12/218
D556,094 S *	11/2007	May	D12/126	D647,166 S *	10/2011	Kimball et al.	D23/202
D556,214 S *	11/2007	Fretwell	D15/5	D655,372 S *	3/2012	Kimball et al.	D23/202
D643,796 S *	8/2011	Heinemann et al.	D12/218	D663,325 S *	7/2012	Thunstrom et al.	D15/28
D644,160 S *	8/2011	Fries et al.	D12/218	D669,099 S *	10/2012	Ringer et al.	D15/28
					D669,100 S *	10/2012	Ringer et al.	D15/28
					D673,587 S *	1/2013	Truan et al.	D15/28

* cited by examiner

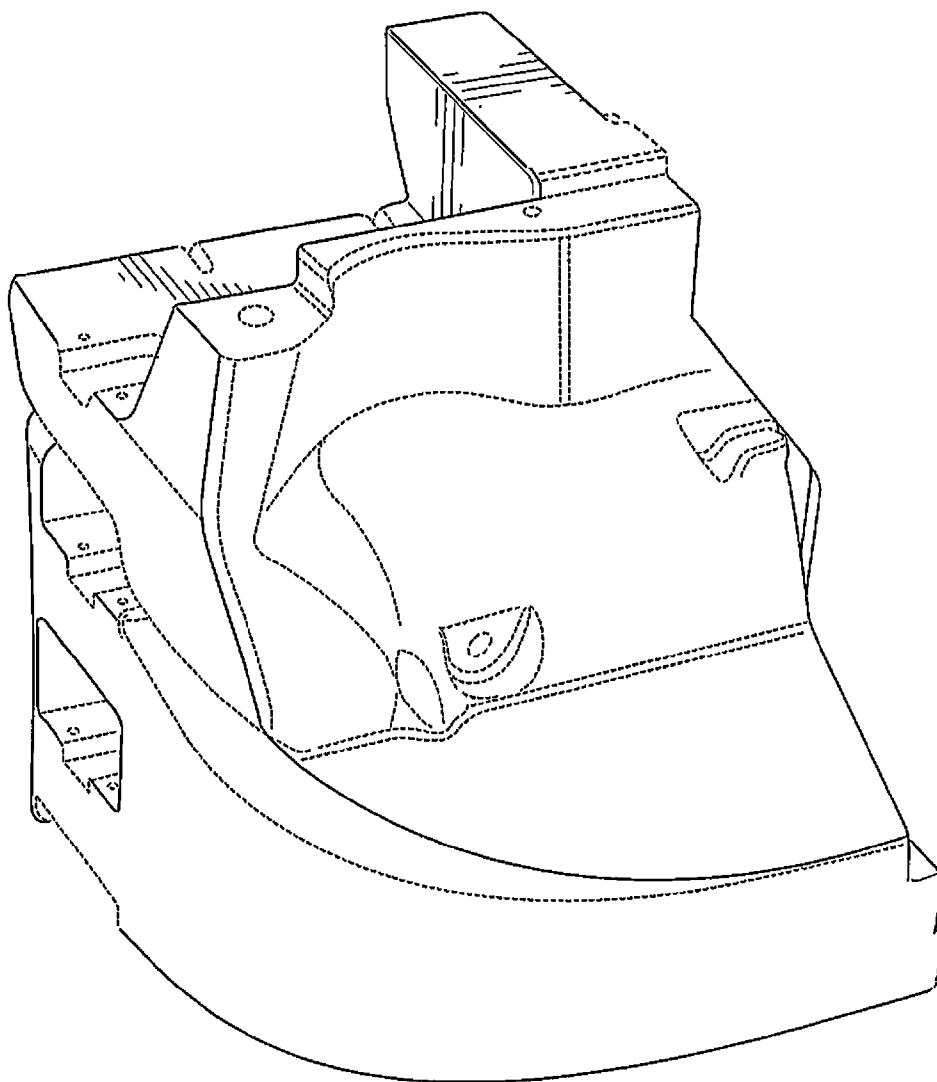

FIG. 1

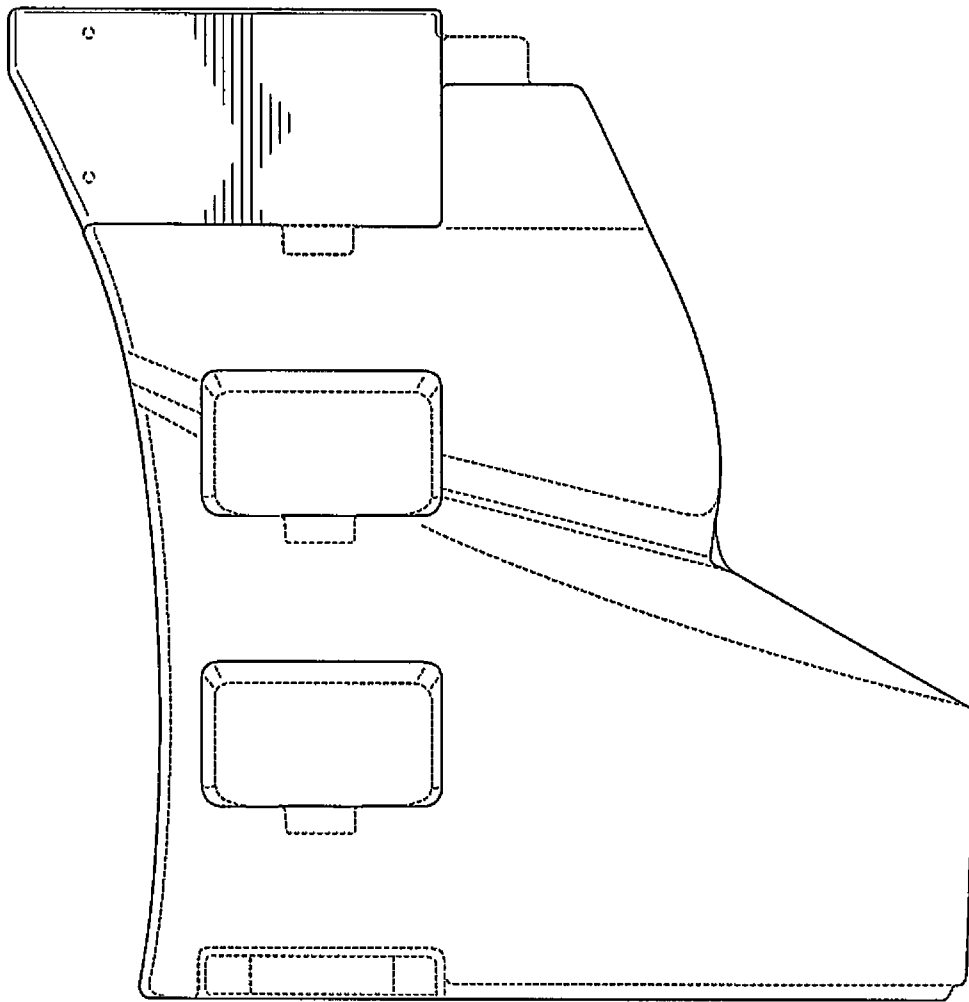

FIG. 2

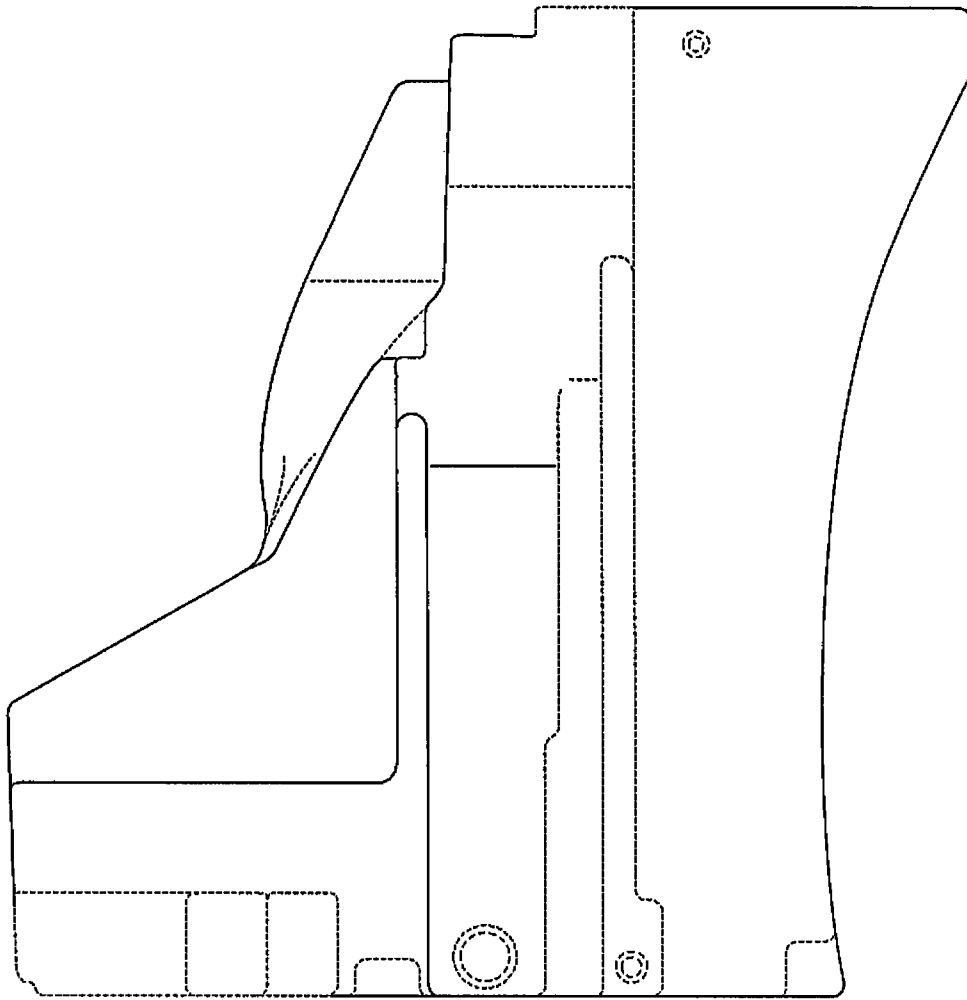

FIG. 3

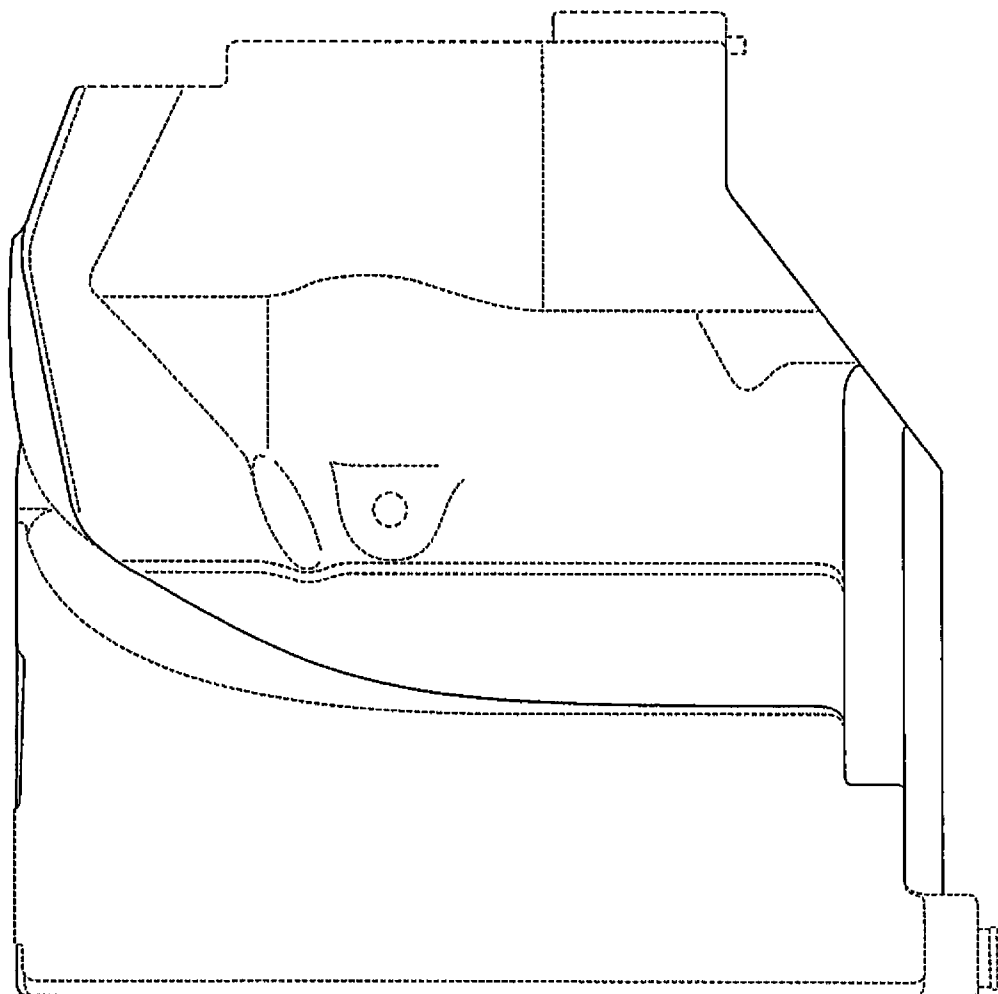

FIG. 4

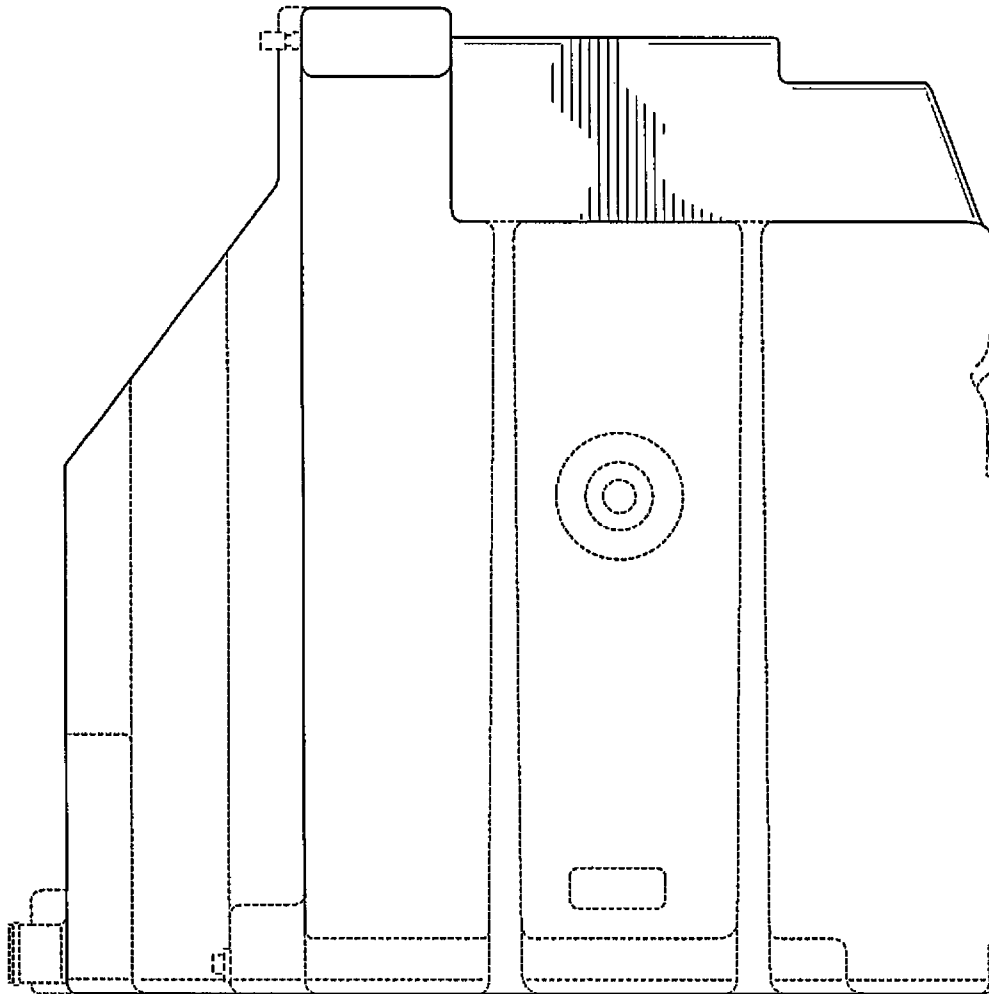

FIG. 5

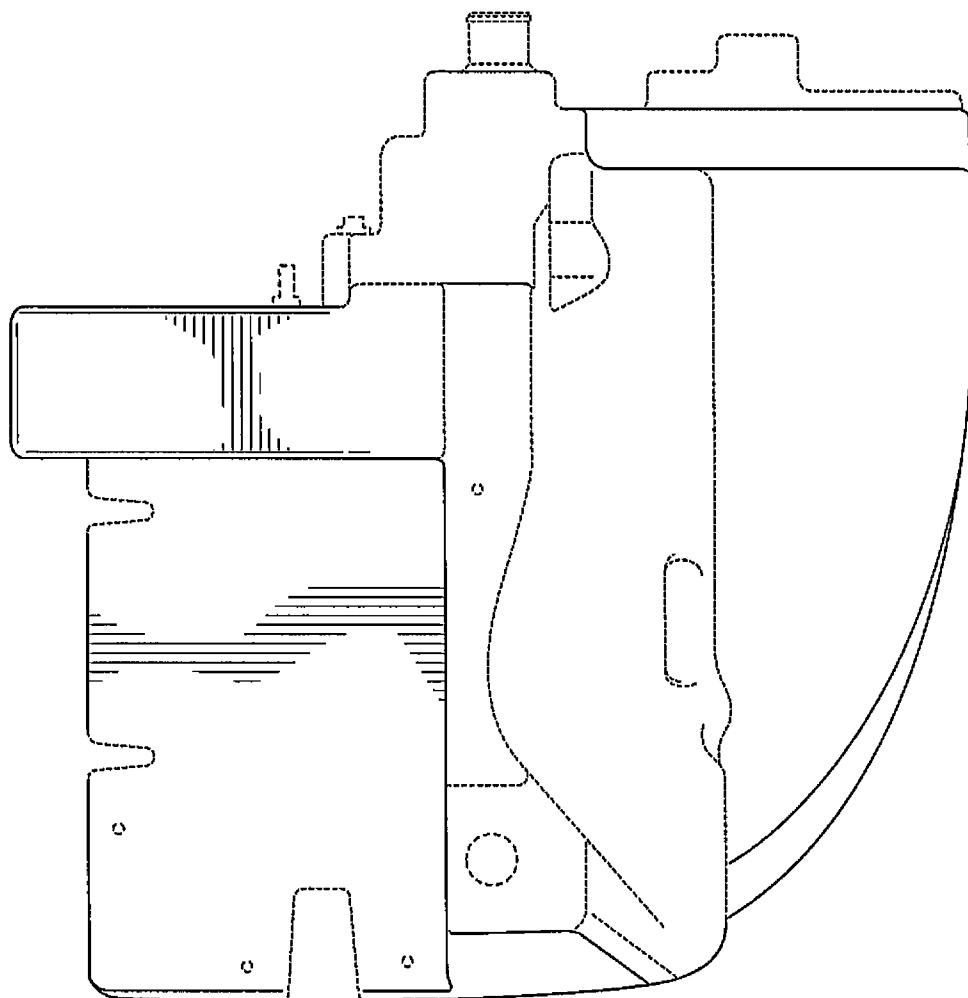

FIG. 6

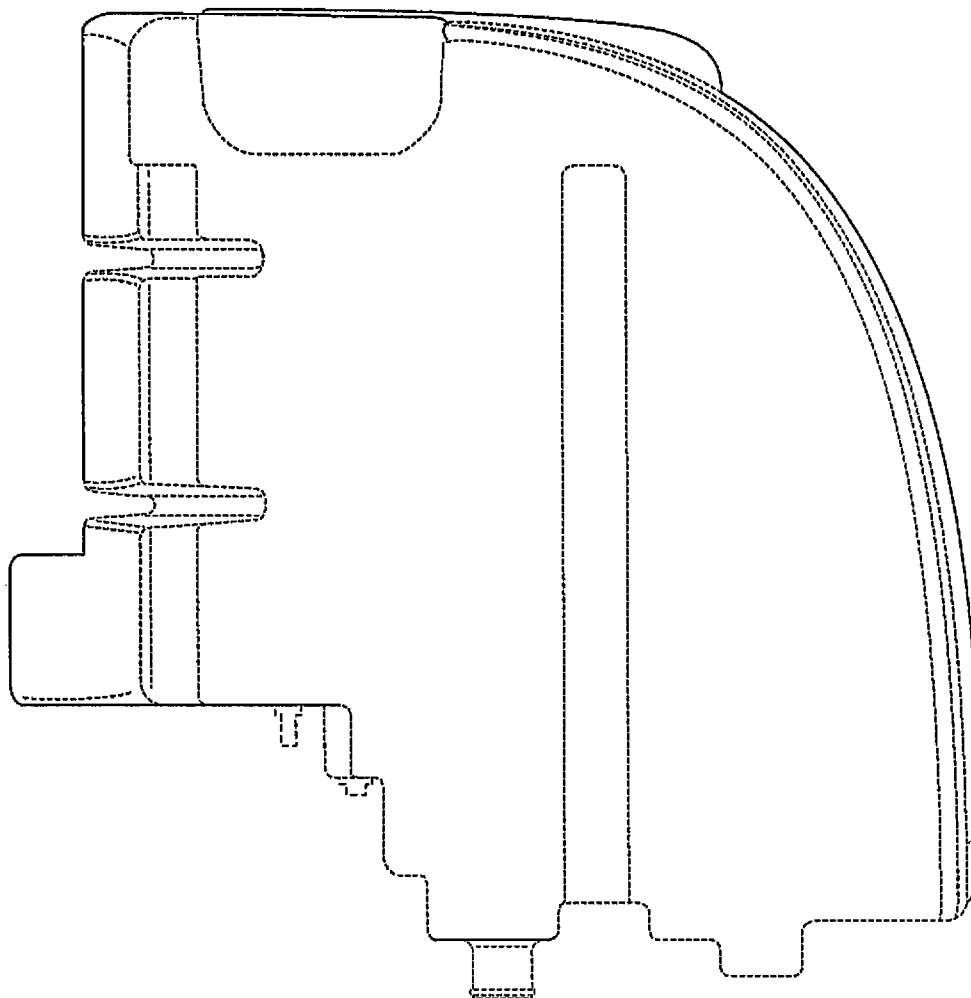

FIG. 7

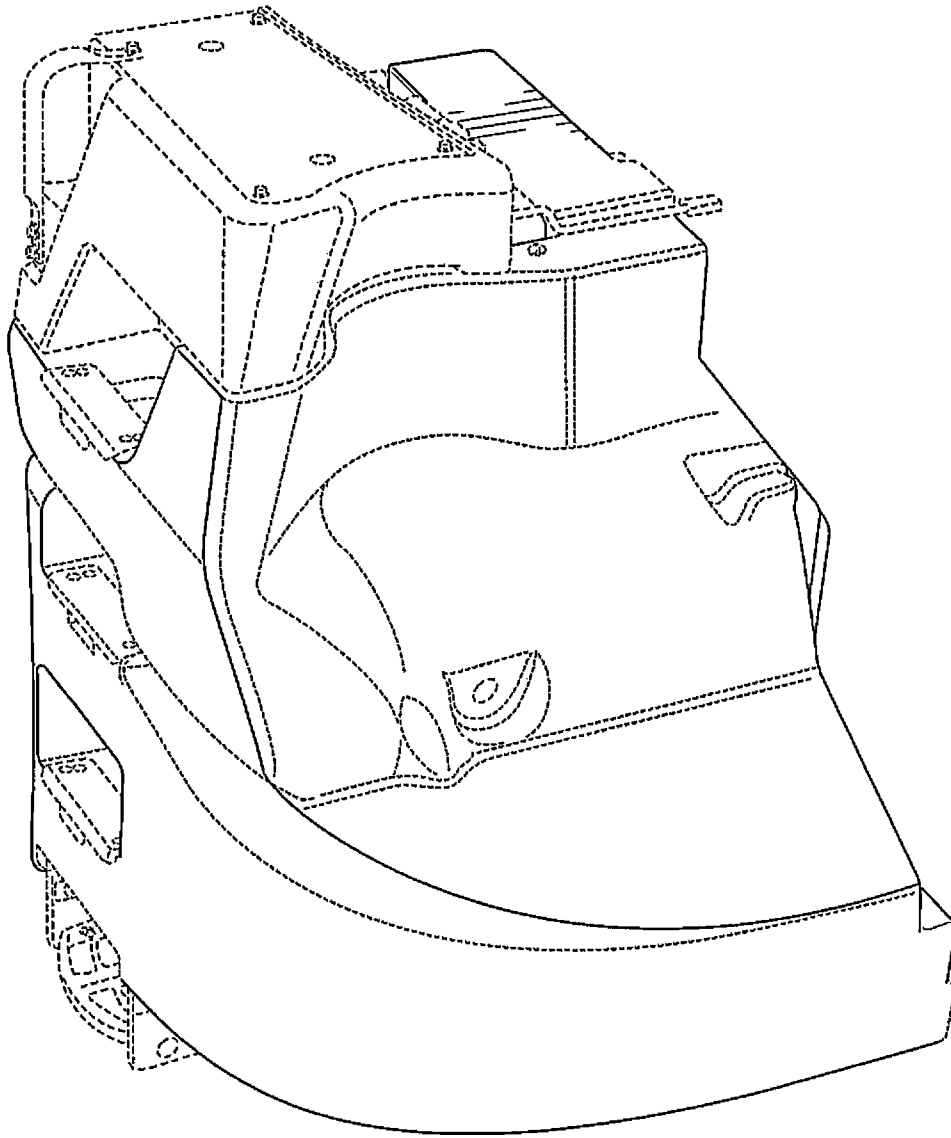

FIG. 8

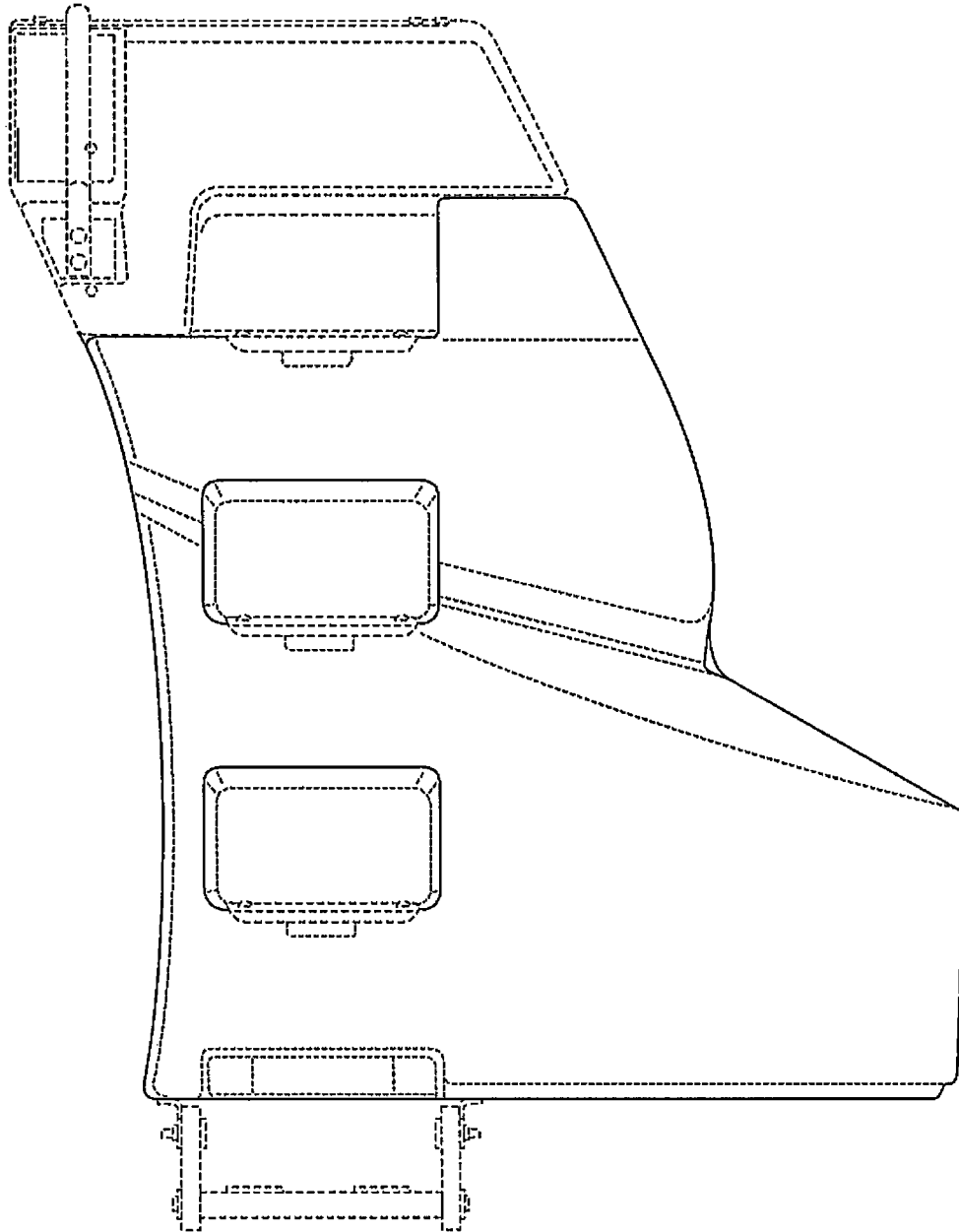

FIG. 9

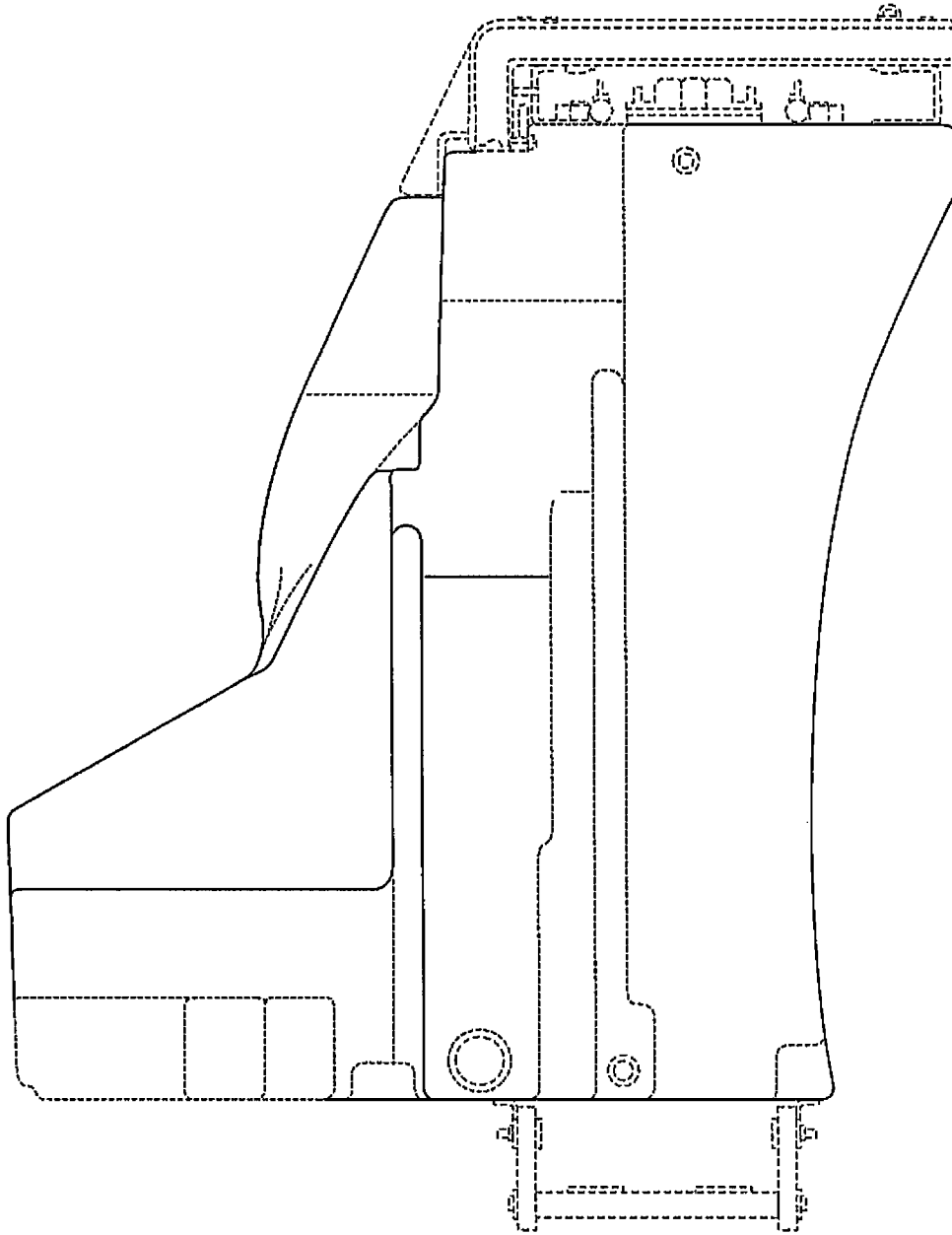

FIG. 10

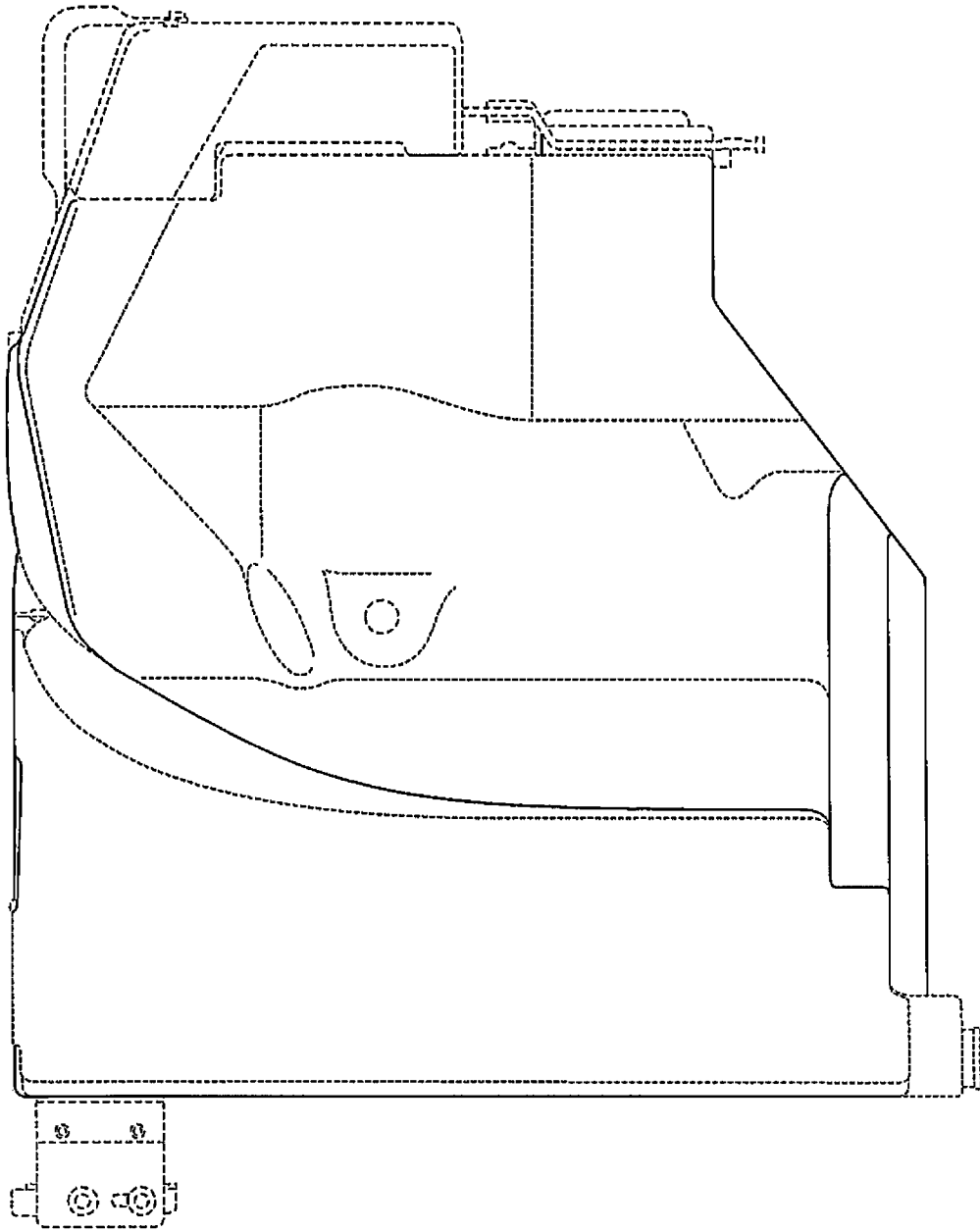

FIG. 11

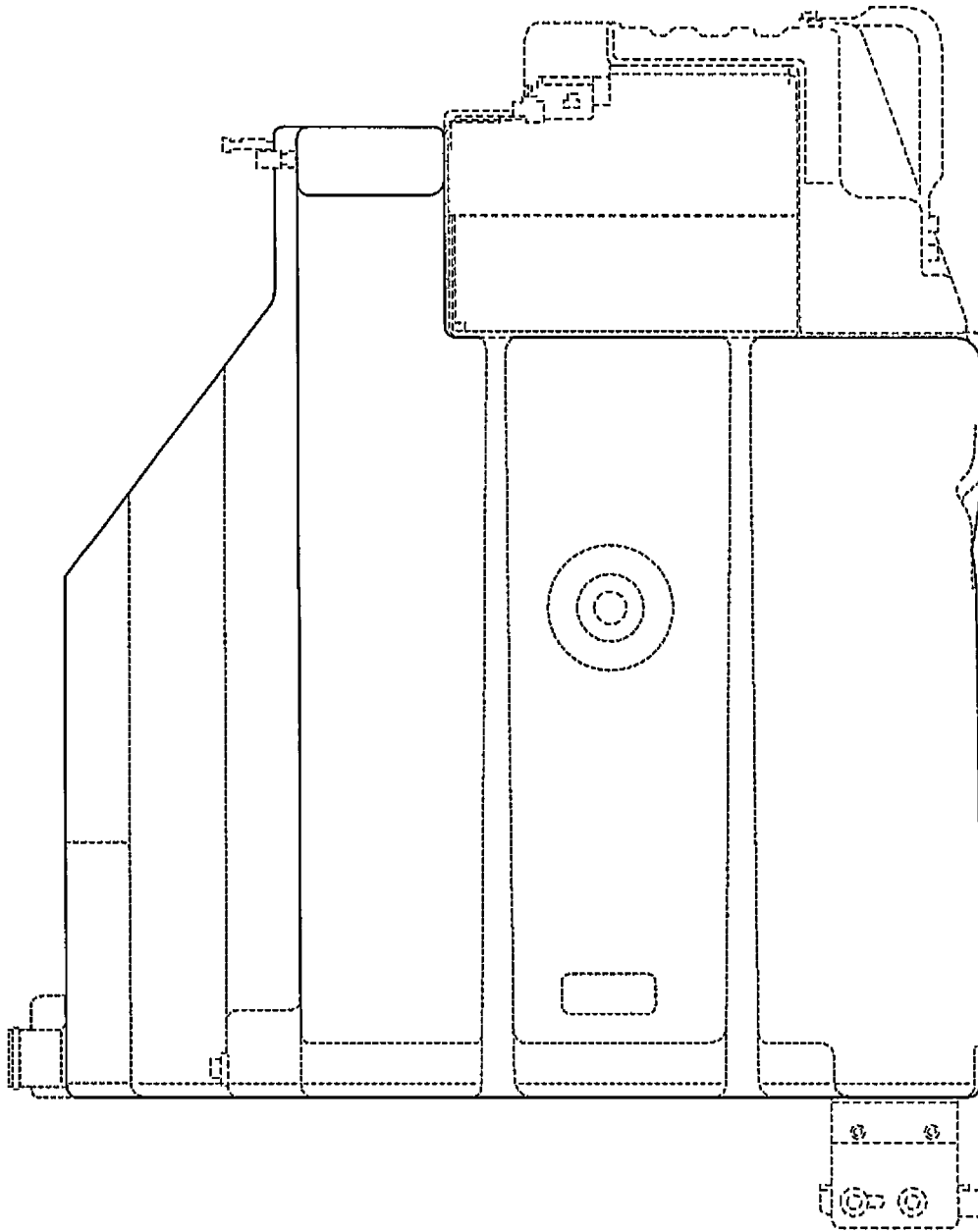

FIG. 12

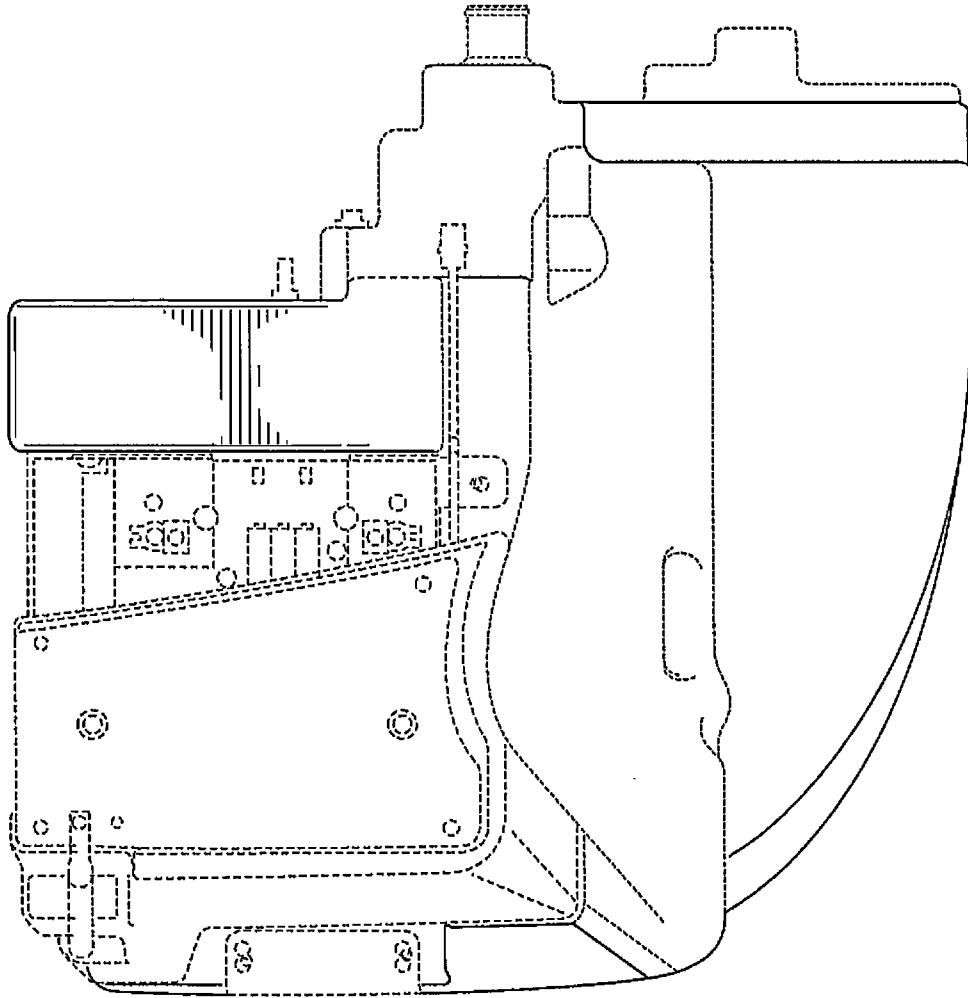

FIG. 13

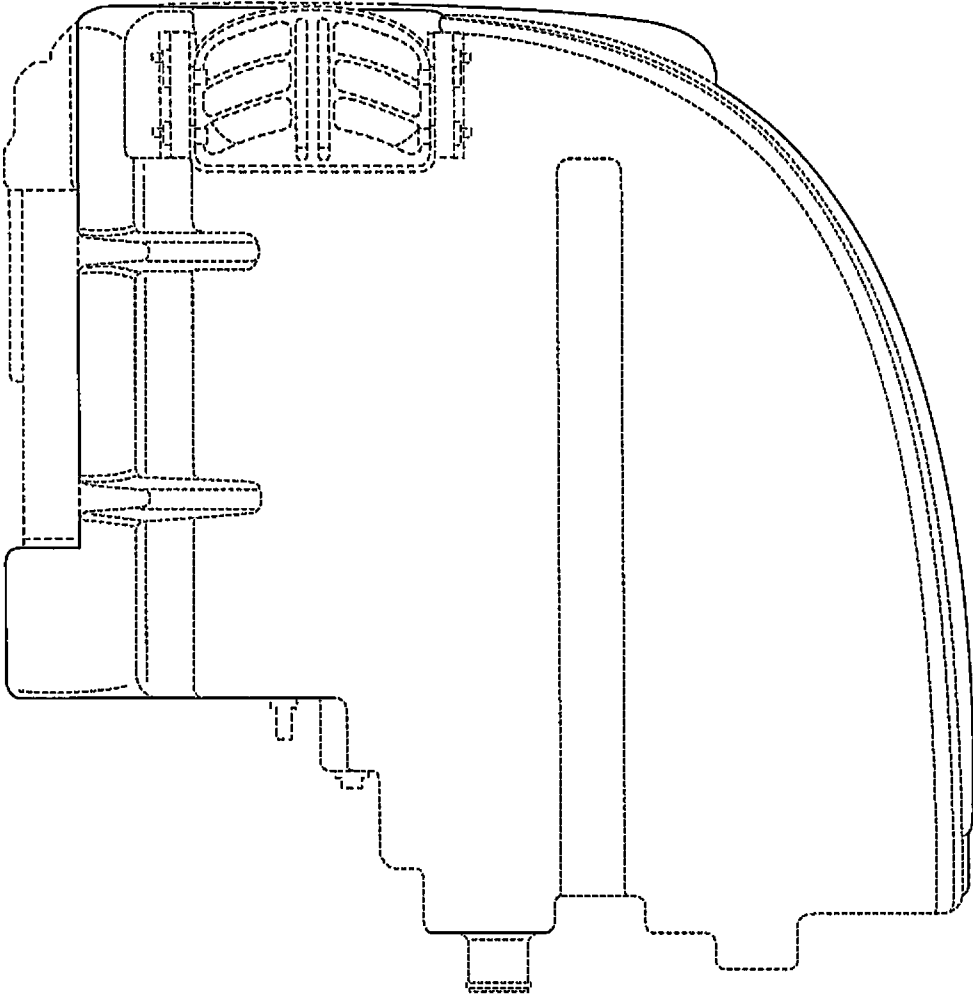

FIG. 14