

No. 802,273.

PATENTED OCT. 17, 1905.

D. G. EIKENBERRY.
CORN SHELLER.

APPLICATION FILED MAR. 8, 1905.

3 SHEETS—SHEET 1.

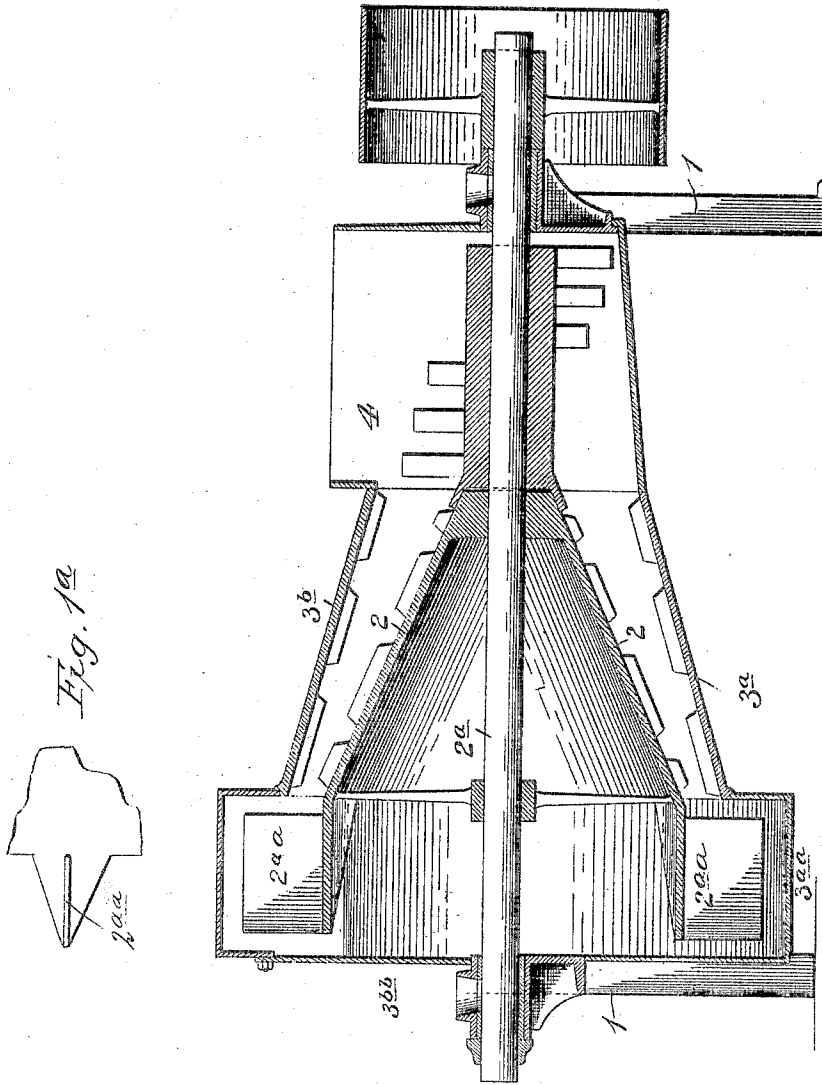
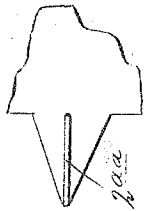

Fig. 1a



WITNESSES:

J. W. Foster
W. H. Cunard

Fig. 1.

INVENTOR
D. G. Eikenberry,

BY
Sam. Baggett Co.
Attorneys

D. G. EIKENBERRY.
CORN SHELLER.

APPLICATION FILED MAR. 8, 1905.

3 SHEETS—SHEET 2.

Fig. 2.

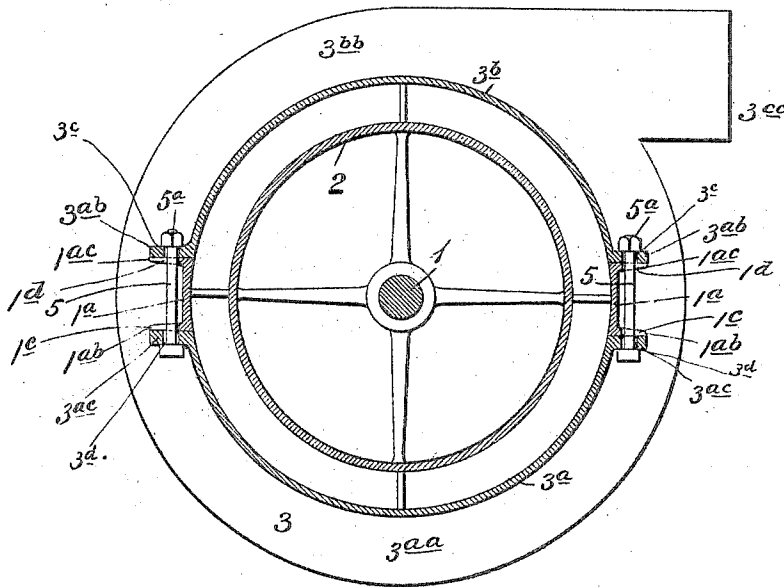
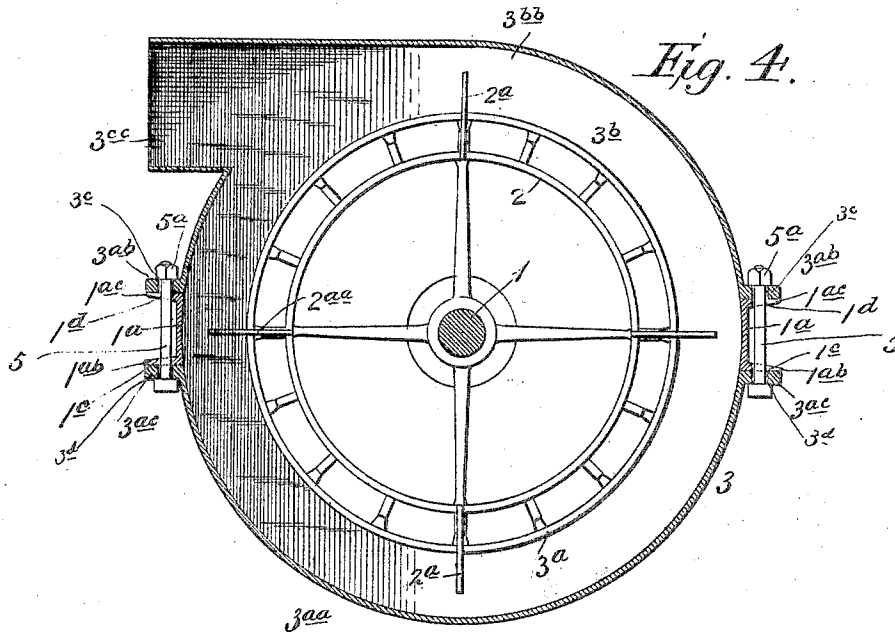

Fig. 4.



WITNESSES:

W. H. Curand.
J. H. Myster

INVENTOR:

D. G. Eikenberry,

By
Lawyer & Co.
Attorneys

D. G. EIKENBERRY.
CORN SHELLER.

APPLICATION FILED MAR. 8, 1905.

3 SHEETS—SHEET 3.

Fig. 3.

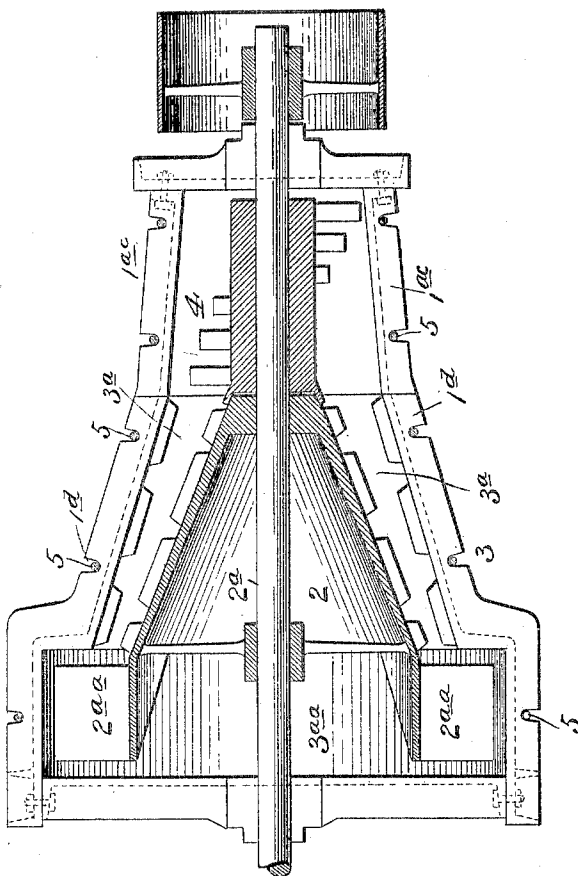

WITNESSES:

W. H. Curran

J. W. Foster

INVENTOR:

D. G. Eikenberry,

By

Sam. Rogers & Co.
Attorneys.

UNITED STATES PATENT OFFICE.

DANIEL G. EIKENBERRY, OF BLOOMINGTON, ILLINOIS, ASSIGNOR OF ONE-HALF TO B. S. CONSTANT COMPANY, OF BLOOMINGTON, ILLINOIS.

CORN-SHELLER.

No. 802,273.

Specification of Letters Patent.

Patented Oct. 17, 1905.

Application filed March 8, 1905. Serial No. 249,052.

To all whom it may concern:

Be it known that I, DANIEL G. EIKENBERRY, a citizen of the United States, residing at Bloomington, in the county of McLean and State of Illinois, have invented new and useful Improvements in Corn-Shellers, of which the following is a specification.

My invention relates to improvements in corn-shellers.

It has for its object, primarily, to simplify the construction of parts, especially with the view to greatly reduce or lessen the expense or cost required to repair or renew any of said parts; also, to provide for the direct delivery or passage of the shelled corn, &c., from the sheller to the usual elevating means and to carry out these ends with facility and effectiveness.

Said invention consists of certain structural features substantially as hereinafter fully disclosed, and particularly pointed out by the claims.

In the accompanying drawings, illustrating the preferred embodiment of my invention, Figure 1 is a vertical longitudinal section thereof. Fig. 1^a is a fractional detailed plan view of one of the blades of one of the sheller members. Fig. 2 is a cross-section produced through the conical or shelling portion of the machine. Fig. 3 is a view, partly in plan and partly in horizontal section thereof; and Fig. 4 is a vertical transverse section taken through the trunk or delivery end of the machine.

In the disclosure of my invention I suitably mount upon a framing 1, of peculiar construction, as presently more fully described, the shaft 2^a of the usual conical member 2 of a sheller and secure to the lower sides or surfaces of the longitudinal pieces or bars 1^a of said framing the lower half member or section 3^a of the casing 3, inclosing said sheller member 2. Said lower casing member or section 3^a is in continuation formed with what constitutes the hopper-bottom or the member forming the bottom of the hopper, presently noted. To the upper surfaces of said longitudinal bars or pieces 1^a is secured the upper half member or section 3^b of said casing 3. Also to the same surfaces of said bars is secured the usual hopper 4 for receiving the ear-corn for feeding to sheller. Said lower and upper casing members are adapted, as shown and as well known, to cooperate with said conical sheller member

in effecting the shelling operation. Heretofore the ordinary form of hopper has had its bottom, which is longitudinally slotted, as well known, secured to the upper surfaces of the framing longitudinal bars and said hopper secured directly upon said bottom, making it necessary to remove all of these in event the bottom member required repairing or renewal. I obviate the necessity of displacing or removing the hopper with the removal of the bottom member by securing said bottom member to the under sides of the framing longitudinal bars, thus separating it from said hopper. In effecting the foregoing connections the longitudinal bars or pieces 1^a of the framing 1 are provided along their upper and lower edges with lateral or outstanding flanges 1^{ab} 1^{ac} and providing said upper and lower casing or sheller members 3^a 3^b along their longitudinal edges with corresponding flanges 3^{ac} 3^{ab} and suitably securing said members to said longitudinal bars by passing bolts 5 through holes 3^c 3^d in said flanges 3^{ab} 3^{ac} and slots 1^c 1^d in said flanges 1^{ab} 1^{ac}, as seen particularly in Fig. 3, said bolts of course being held in place by nuts 5^a, applied to their threaded end portions. Said longitudinal bars 1^a of the framing are also suitably adapted or equipped, as shown especially in Fig. 3, for coaction with the conical sheller member 2 in effecting the shelling operation.

Both the lower casing-section and that part thereof forming the bottom of the hopper 4 are imperforate throughout, as distinguished from the corresponding parts of the ordinary form of sheller. Said lower casing member or section has its flared or delivery end enlarged into a semicircular or arcuate trough-like terminal 3^{aa} and the upper casing member or section similarly enlarged or terminated at its corresponding end, with the arcuate trough-like terminal thereof, 3^{bb}, thus formed opposed to and forming a continuation of the part 3^{aa}, thus conjointly constituting a circular chamber to receive the shelled corn and cobs from the sheller as the same are thrown thereinto by the centrifugal action of the latter. Said upper part 3^{bb} is provided with a trunk-like outlet or chute 3^{cc}, which in practice connects with and delivers into a corresponding length of conductor.

The sheller member 2 is equipped or armed at the peripheral edge of its enlarged or flared end with outstanding right-lined blades, lugs,

or flanges 2^{aa}, spaced apart at certain intervals and adapted to engage the corn and cobs as they issue from the sheller and effective to direct the same in the plane of the circular end chamber formed by the parts 3^{aa} 3^{bb} and expedite the delivery of said corn and cobs out through the chute or outlet 3^{cc} for the advantageous disposal thereof, as is apparent. The sheller has its shaft driven by any means for effecting the shelling operation.

It will be noted that by the foregoing construction and arrangement of parts the making, as heretofore practiced, of an excavation or "pit" is avoided, into which to locate or sink the base end of an "elevator-boot" to provide for delivering therein by gravity the contents from the sheller, which pit or excavation has usually had arranged therein a steel or cast-iron tank or been lined with cement for protection of the elevator, &c., from water, &c., all of which is expensive and unnecessarily elaborate.

Latitude is allowed regarding details herein, since they may be changed as circumstances suggest without departing from the spirit of my invention.

I claim—

1. A machine of the character described, comprising two casing members, practically semiconical in general outline the greater portion of their lengths, with the outer flared portions thereof terminating in lateral semi-circular enlargements conjointly forming a circular discharging chamber, lower and upper rectangular hopper sections or members, lateral longitudinal bars of corresponding outline with said casing and hopper sections or members, respectively, and effective for attachment to the latter, and a rotary sheller member arranged within said casing members and adapted for coaction therewith, and car-

rying at its flared end radial outstanding flanges or blades arranged to extend into the aforesaid circular chamber of said casing members.

2. A machine of the character described, comprising casing members, having their flared ends provided with arcuate offset portions conjointly forming an annular chamber having a right-lined outlet or chute, one of said casing members forming the hopper-bottom, and the other hopper member serving to support said hopper-bottom and the hopper, a rotary sheller member having its flared end provided with outstanding blades or flanges, arranged in said chamber, in radial lines with relation to the axis of said sheller member, and a supporting-frame having its longitudinal bars provided at their upper and lower edges with lateral flanges having securing bolts or fastenings passing therethrough, also inserted through flanges of said casing members.

3. A machine of the character described, comprising a sheller member having outstanding from its delivery end flanges, blades or lugs, an inclosing casing therefor having an enlarged annular chamber receiving said flanges, blades or lugs, said casing embracing the hopper-bottom member provided with lateral flanges, a supporting-frame having its longitudinal bars or pieces provided along their longitudinal edges with lateral flanges and fastening-bolts passing through openings, and slots produced in said flanges, respectively.

In testimony whereof I affix my signature in presence of two subscribing witnesses.

DANIEL G. EIKENBERRY.

Witnesses:

F. Y. HAMILTON,
IONA G. CONSTANT.