



(11) **EP 2 415 371 B1**

(12) **EUROPEAN PATENT SPECIFICATION**

(45) Date of publication and mention of the grant of the patent:  
**13.03.2013 Bulletin 2013/11**

(51) Int Cl.:  
**A47F 1/12 (2006.01)**

(21) Application number: **11187314.7**

(22) Date of filing: **22.01.2009**

(54) **Product management display system with trackless pusher mechanism**

Produktverwaltungsanzeigesystem mit schienenlosem Schiebemechanismus

Système d'affichage de gestion de produits doté d'un mécanisme de poussée sans rail

(84) Designated Contracting States:  
**AT BE BG CH CY CZ DE DK EE ES FI FR GB GR HR HU IE IS IT LI LT LU LV MC MK MT NL NO PL PT RO SE SI SK TR**  
Designated Extension States:  
**RS**

(30) Priority: **25.01.2008 US 62571 P**

(43) Date of publication of application:  
**08.02.2012 Bulletin 2012/06**

(62) Document number(s) of the earlier application(s) in accordance with Art. 76 EPC:  
**09703688.3 / 2 242 401**

(73) Proprietor: **RTC INDUSTRIES, INC.**  
**Rolling Meadows, IL 60008 (US)**

(72) Inventor: **Hardy, Stephen N.**  
**Wadsworth**  
**Ohio 44281 (US)**

(74) Representative: **Lucas, Brian Ronald**  
**Lucas & Co.**  
**135 Westhall Road**  
**Warlingham,**  
**Surrey CR6 9HJ (GB)**

(56) References cited:  
**EP-A- 1 857 021 US-A1- 2005 199 564**  
**US-A1- 2005 199 565 US-A1- 2006 226 095**

**EP 2 415 371 B1**

Note: Within nine months of the publication of the mention of the grant of the European patent in the European Patent Bulletin, any person may give notice to the European Patent Office of opposition to that patent, in accordance with the Implementing Regulations. Notice of opposition shall not be deemed to have been filed until the opposition fee has been paid. (Art. 99(1) European Patent Convention).

**Description**

## FIELD OF THE INVENTION

**[0001]** The exemplary embodiments of the invention relate generally to a shelf assembly for use in merchandising product and more particularly to a shelf assembly having improved mechanisms for displaying and pushing product on the shelves.

## BACKGROUND OF THE INVENTION

**[0002]** It is known that retail and wholesale stores, such as convenience stores, drug stores, grocery stores, discount stores, and the like, require a large amount of shelving both to store product and to display the product to consumers. In displaying product, it is desirable for the product on the shelves to be situated toward the front of the shelf so that the product is visible and accessible to consumers. In the case of coolers or refrigerators that are used to store and display such products as soft drinks, energy drinks, bottled water, and other bottled or canned beverages, it is desirable for these products to also be situated toward the front of the shelf and visible and accessible to the consumers.

**[0003]** To accomplish this placement of product, known systems may include inclined trays or floors that through gravity will cause the product to move toward the front of the shelf. Many of these systems include floors or shelves made of a plastic material such as polypropylene that due its low coefficient of friction permit the product to easily slide along the inclined floor or surface. However, over time, these surfaces can become obstructed with debris or sticky substances that inhibit the product from properly sliding, sometimes causing several products to tip over thus blocking additional product from moving to the front of the shelf.

**[0004]** Other systems include the use of a pusher system to push the product toward the front of the shelf as the product at the front of the shelf is removed. The known pusher systems are typically mounted to a track and include a pusher paddle and a coiled spring to urge the product forward. Occasionally, as the system is used, and over time, the track becomes obstructed with dirt or sticky materials that hinder the proper operation of the pusher system in the track. In addition, depending on the size, shape and weight of the product to be merchandised, the known pusher paddles may occasionally tip or bend backwards, thereby causing a binding of the pusher mechanism in the track. In those situations, the pusher mechanism may not properly push product toward the front of the shelf

**[0005]** One exemplary embodiment is directed at improving upon existing merchandising systems by providing a trackless pusher system that works with gravity-fed merchandise systems (i.e., inclined shelves or trays) and non-gravity-fed merchandise systems.

**[0006]** US Patent Specification 2005/0199564 de-

scribes a two tier merchandising system.

## SUMMARY OF THE INVENTION

**[0007]** According to the present invention there is provided a product management display system comprising a first tray (402) and a second tray (404) each having a first wall and a second wall, the first (402) and second (404) tray each adapted to receive a pusher mechanism (412), and a retainer mechanism (410); a plurality of spacers (406, 408) mountable to the first and second trays (402, 404) for stacking the first tray (402) above the second tray (404) wherein each of the plurality of spacers (406, 408) further comprise a plurality of detents (416), the first tray (402) and the second tray (404) each having a plurality of correspondingly shaped sockets (418) on an outer surface, wherein each of the plurality of sockets (418) is configured to receive one of the plurality of detents (416) and characterized by the retainer mechanism (410) being attached to a front portion of the tray and including a floor and a two curved sidewalls.

**[0008]** One exemplary embodiment is directed to a product management display system for merchandising product on a shelf. This embodiment includes using a trackless pusher mechanism that travels along a surface on which product is placed. The trackless system overcomes the known problems with the use of tracks to hold and guide the known pusher mechanisms. It should be understood however that the teachings of this embodiment may be used with systems that include tracks for mounting a pusher mechanism or the like.

**[0009]** The pusher mechanism can include a pusher paddle and a floor that extends forward of the pusher paddle. A flat coiled spring or biasing element can extend across the divider to the front of the shelf assembly. With this configuration, the pusher paddle is prevented from tipping or bending backwards during operation.

**[0010]** An exemplary embodiment also includes the use of a pushing mechanism with the merchandising of product on horizontal or non-inclined shelves or surfaces, as well as with gravity-fed systems, or systems that use gravity as a mechanism to urge product toward the front of the shelf.

**[0011]** In accordance with an exemplary illustrative embodiment of the invention, the pusher paddle may define a concave pushing surface for pushing cylindrical products, such as soft drink bottles or cans, and to keep the paddle centered on the track and behind the product. Alternatively, the pusher paddle may define a flat pushing surface that may further include at its upper edge a curved rib or similar structure that can also be used to push cylindrical products.

**[0012]** In accordance with another exemplary illustrative embodiment of the invention, the floor of the pusher mechanism can include a notched or cut-out portion to align the pusher mechanism relative to the coiled spring. Also, the floor of the system also can include a notch or cut-out portion for receiving and mounting a flat end of

the coiled spring to the floor. A spring tip may be placed on the end of the coiled spring to mount the coiled spring to the floor of the system. Alternatively, the end of the coiled spring can mount to the divider of the assembly.

**[0013]** In accordance with yet another exemplary embodiment, an adaptor for a product management display system may be positioned on a floor surface of the display system. The adaptor may include a planar surface with at least two ribs extending outwardly from the planar surface and across the planar surface in a substantially parallel manner. A coiled spring may be positioned between the parallel extending ribs. With this configuration, product to be merchandised may sit on the ribs, and not directly on the coiled spring, to enhance the forward movement of certain types of product, such as cans of a beverage.

**[0014]** In yet another alternative aspect, a mounting member may be used to mount the end of the coiled spring to the floor of the system. For those systems that include spaced-apart glide rails that are joined together by connecting ribs, the mounting member may be snap-fit to or otherwise mounted on the floor and between the glide rails.

**[0015]** In yet another alternative aspect, the trackless pusher system is retrofitted into an existing shelf assembly. This allows for the placement of the trackless pusher system in an existing shelving system as a low cost alternative to purchasing the entire trackless pusher assembly.

**[0016]** In another exemplary embodiment, the coil spring can be mounted to the retainer. An end of the coil spring can be directly mounted to the retainer or alternatively the end can be mounted to the retainer via an adapter. The adapter can have a curved portion which is received in a correspondingly shaped curved slot in the retainer to secure the end of the spring to the display assembly.

**[0017]** In another exemplary embodiment, the trays can be attached via a dovetail connection to form a shelf assembly. Additionally the dividers can be adjusted such that the width of the product rows can be adapted to receive different sized products.

**[0018]** In accordance with yet another exemplary embodiment, the product management display system can be arranged in a stackable arrangement. The assembly can be provided with a first tray and a second tray each having a first wall and a second wall. The first and second trays are each adapted to receive a pusher mechanism, and a retainer mechanism. First and second spacers are mounted to the first and second trays for stacking the first and second trays on top of one another. The first and second spacer can be provided with a plurality of detents, and the first tray and the second tray can each be provided with a plurality of correspondingly shaped sockets for receiving the plurality of detents.

## BRIEF DESCRIPTION OF THE DRAWINGS

### [0019]

5 Figure 1 depicts an isometric exploded view of an exemplary embodiment of a product management display system of the present invention.

10 Figure 2 depicts an isometric view of an exemplary pusher mechanism mounted to an exemplary tray or product channel of the present invention.

15 Figure 3 depicts another isometric view of the system of Figure 2 with product placed in the system.

20 Figure 4 depicts another isometric view of the system of Figure 2 with multiple product placed in the system.

25 Figure 5 depicts an isometric rear view of the system of Figure 4.

30 Figure 6 depicts an alternative embodiment of the tray or product channel of the present invention.

35 Figure 7 depicts an exemplary tip for an end of a coiled spring that may be used with the product management display system of the invention.

40 Figure 8 depicts the exemplary tip of Figure 7 being mounted to a surface of a tray or product channel.

45 Figure 9 depicts the exemplary tip of Figure 7 being mounted to an end of a coiled spring.

50 Figure 10 depicts the exemplary tip of Figure 7 mounted to an end of a coiled spring.

55 Figure 11 depicts an isometric view of an alternative exemplary embodiment of a product management display system of the present invention.

60 Figure 12 depicts another isometric view of the system of Figure 11.

65 Figure 13 depicts a front view of the system of Figure 11.

70 Figure 14 depicts a top view of the system of Figure 11.

75 Figure 15 depicts a rear view of the system of Figure 11.

80 Figure 16 depicts an isometric view of an adaptor that may be used with the invention.

85 Figure 17 depicts a front view of the adaptor of Figure

16.

Figure 18 depicts an exemplary installation of the adaptor of the invention.

Figure 19 depicts an isometric view of an installed adaptor of the invention.

Figure 20 depicts a front view of an installed adaptor of the invention.

Figure 21 depicts an isometric view of an alternative exemplary embodiment of a product management display system of the present invention.

Figure 22 depicts an isometric bottom view of an exemplary mounting member that may be used to mount the end of the coiled spring to the floor of the display system.

Figure 23 depicts an isometric top view of the exemplary mounting member of Figure 22.

Figure 24 depicts the exemplary mounting member of Figure 22 mounted to the end of the coiled spring with the coiled spring mounted to an exemplary pusher paddle.

Figure 25 depicts another view of the exemplary mounting member of Figure 22 mounted to the end of the coiled spring with the coiled spring mounted to an exemplary pusher paddle.

Figure 26 depicts the exemplary mounting member of Figure 22 with attached coiled spring being mounted to the floor of the system.

Figure 27 depicts the exemplary mounting member of Figure 22 installed on the floor of the system.

Figure 28 depicts an isometric view of an alternative exemplary embodiment of a product management display system of the present invention.

Figure 29 depicts a close-up isometric view of the tray of the exemplary embodiment of Figure 28.

Figure 29A depicts a cross-sectional view of the exemplary embodiment of Figure 28 illustrating a first securing method.

Figure 29B depicts a cross-sectional view of the exemplary embodiment of Figure 28 illustrating a second securing method.

Figure 30 depicts a close-up isometric view of the embodiment of Figure 28 illustrating a rivet attaching the spring to the tray.

Figure 31 depicts an isometric view of the embodiment of Figure 28 being assembled in a preexisting wire shelf.

Figure 32 depicts an isometric view of the embodiment of Figure 28 assembled in a preexisting wire shelf.

Figure 33 depicts an isometric view of an exemplary embodiment of the display system.

Figure 34 depicts an isometric view of an exemplary embodiment of the display system.

Figure 35 depicts an isometric view of an exemplary embodiment of an adapter.

Figure 36 depicts an isometric view of an exemplary embodiment of a retainer.

Figure 37 depicts a side view of an exemplary embodiment of the display system.

Figure 38 depicts an isometric view of an exemplary embodiment of the display system.

Figure 39 depicts an isometric view of an exemplary embodiment of the display system.

Figure 40 depicts an isometric view of an exemplary embodiment of the display system.

Figure 41 A depicts a sectional side view of an exemplary embodiment of a divider.

Figure 41 B depicts a front view of an exemplary embodiment of the display system.

Figure 41 C depicts a close up view of a section of Figure 41 B.

Figure 41D depicts a front view of an exemplary embodiment of a divider.

Figure 42 depicts an isometric view of an exemplary embodiment of the display system.

Figure 43 depicts an isometric view of an exemplary embodiment of the display system.

Figure 44 depicts an isometric view of an exemplary embodiment of a product management display system.

Figure 45 depicts another isometric view of an exemplary embodiment of a product management display system with product in the system.

Figure 46 depicts a top view of another exemplary embodiment of a product management display system with product in the system.

Figure 47 depicts an isometric-rear view of an exemplary embodiment of a product management display system with product in the system.

Figure 48 depicts an isometric view of an exemplary embodiment of the pusher mechanism mounted to a divider.

Figure 49 depicts another isometric view of the divider and pusher mechanism being assembled to the product management display system.

Figure 50 depicts an isometric view of yet another exemplary embodiment of the product management display system.

Figure 51 depicts another isometric view of the exemplary embodiment of the product management display system of Figure 50 without product.

Figure 52 depicts an exploded isometric view of the exemplary embodiment of the product management display system of Figure 50.

**[0020]** Before the embodiments of the invention are explained in detail, it is to be understood that the invention is not limited in its application to the details of construction and the arrangement of the components set forth in the following description or illustrated in the drawings. The invention is capable of other embodiments and of being practiced or being carried out in various ways. Also, it is to be understood that the phraseology and terminology used herein are for the purpose of description and should not be regarded as limiting. The use of "including" and "comprising" and variations thereof is meant to encompass the items listed thereafter and equivalents thereof as well as additional items and equivalents thereof. Further, the use of the term "mount," "mounted" or "mounting" is meant to broadly include any technique or method of mounting, attaching, joining or coupling one part to another, whether directly or indirectly.

#### DETAILED DESCRIPTION OF THE EMBODIMENTS

**[0021]** The invention may be embodied in various forms. Referring to the Figures wherein like numerals indicate like elements, there is depicted in Figure 1 an isometric exploded view of an exemplary embodiment. Exemplary merchandise system 10 includes a product dispensing tray 12 in which is mounted an exemplary trackless pusher mechanism 14. As described in more detail below, the pusher mechanism 14 will fit in the tray 12 and will slide along the surface of the tray without the use of tracks, rails, or guides typically used to hold a

conventional pusher mechanism to the tray or floor of the tray. The pusher mechanism defines a pusher paddle and a pusher floor that extends forward of the pusher paddle. A coiled spring may extend across the pusher floor and operatively connect to the tray at a forward position on the tray. In one aspect of the invention, product to be merchandised may be placed in the tray in front of the pusher paddle and may sit on the pusher floor as well as the coiled spring. With this configuration, the weight of the product will prevent the pusher paddle from tipping to ensure proper pushing of the product. In addition, the problems associated with debris or sticky materials hindering the effectiveness of known pusher systems that use tracks, rails or guides have been eliminated. Other aspects, embodiments and features of the invention and its teachings are set forth in more detail below.

**[0022]** The exemplary tray 12 may define a surface 16 and one or more dividing panels or dividers 18 to separate the tray into numerous rows for placement of product. In an alternative aspect, the tray 12 may be a shelf or any other surface on which products may be placed for merchandising. The surface 16 may be a solid surface or a surface defining a plurality of spaced-apart apertures 20 separated by a plurality of support ribs 22. The apertures 20 and ribs 22 provide a surface that permits the slidable movement of product placed on this surface and also permits liquids and dirt to pass through the apertures 20 so that they do not collect on the surface 16. The surface 16 may be made of any suitable material that permits the slidable movement of product on the surface 16. Other surface or floor configurations are known and may be used with the principles of the invention.

**[0023]** As depicted in Figures 9 and 10, the surface 16 may define a rounded end portion 24 that includes a notch or cut-out portion 26. The end portion 24 may be rounded to match the shape of the product that is placed on the tray. For example, the depicted end portion 24 is rounded or defines a semi-circular shape to match the contour of a bottle or can that may be placed in the tray and on the end portion 24. Other shapes of the end portion may be used with the invention depending on the product to be merchandised.

**[0024]** The notch 26 may be used to receive and mount an end 29 of a coiled spring 30 or similar biasing element. The notch 26 may define opposing angled edge surfaces 32 that are joined by edge 34. The edge 34 is preferably centered across the width of the product row formed in the tray 12 and extends perpendicular to the length of the tray. This configuration will center the coiled spring 30 relative to the tray 12 and will permit the spring to extend in a substantially parallel manner relative to the length of the tray. In other words, the depicted edge 34 of the notch 26 will permit the spring 30 to extend along the length of the tray 12 at or near the center of the product row formed by the tray. One skilled in the art will appreciate that the location and configuration of the notch may vary depending on the desired placement of the spring.

**[0025]** The coiled spring 30 may define an end 29 that

is configured to be placed across the notch 26 and onto the edge 34. In one aspect, the end 29 of the coiled spring may be V-shaped and function as a hook such that the end 29 will wrap around the edge 34 with a portion of the end 29 of the coiled spring extending beneath the end portion 24 of the surface 16. This configuration permits an easy installation of the coiled spring onto the tray.

**[0026]** In another aspect, and referring to Figure 7, a spring tip 60 may be added to the end 29 of the spring 30 to assist with the mounting of the spring to the system. The spring tip 60 may define numerous shapes and configurations depending on the configuration of the tray and the surface on which the spring end needs to attach. The spring tip 60 may be permanently attached to the end 29 of the coiled spring 30 or it may be detachable to permit the interchange or replacement of the spring tip 60. The spring tip 60 may be made of plastic and may define one or more apertures. Aperture 61 may be used to receive the end 29 of the coiled spring 30. A second aperture 63 may be used to receive a mating tongue or mounting member 65 extending from the surface 16 of the tray 12, as discussed below. With this configuration, the end 29 of the coiled spring 30 may be operatively connected to the tray 12.

**[0027]** In another aspect, the end 29 of the coiled spring may snap-fit into an aperture formed in the surface 16, or may be otherwise inserted and secured to an aperture or opening in the tray, thereby securing the end 29 of the coiled spring 30 in position.

**[0028]** Referring back to Figure 1, dividers 18 may also be used to separate product into rows. The dividers 18 extend substantially upwardly from the surface 16 and as illustrated in Figure 1, may be positioned on opposing sides of the surface 16. Alternatively, the dividers 18 may be positioned at any desired position on the tray 12 or to the surface 16. The dividers 18 may be formed as a unitary structure with the surface 16, or the dividers 18 may be detachable to provide added flexibility with the system. The dividers may be attached to a front or back rail depending on the system. The dividers 18 may define numerous configurations and may extend upwardly any desired distance to provide the desired height of the dividers between the rows of product to be merchandised. This height may be adjustable by adding divider extenders or the like.

**[0029]** Located at the front of the tray 12 and extending between the dividers 18 may be one or more product-retaining members 44. The product-retaining members 44 serve as a front retaining wall or bar to hold the product in the tray 12 and to prevent the product from falling out of the tray 12. These members are also configured to permit the easy removal of the forward-most product positioned in the tray 12. The product-retaining member 44 may be one or more curve-shaped retaining ribs as depicted in Figure 1. These illustrated retaining ribs may extend from one divider to another divider thereby joining the dividers. The retaining ribs may also extend part-way between the dividers, as also shown in Figure 1 as rib

46, to also assist in retaining the product in the tray. Alternatively, and as shown in Figure 6 the product-retaining member 44 may be a curve-shaped solid retaining wall 48 that extends between dividers. The retaining wall 48 may be transparent or semi-transparent to permit visualization of the product on the shelf. In another aspect, the retaining wall 48 may also extend part-way between the dividers 18. In yet another embodiment depicted in Figures 11-15, the retaining wall 100 may be attached to the surface of the tray and not connect to the dividers. In this embodiment, the retaining wall 100 may form an opening 102 defined by an upper member 104, opposing, curved side walls 106 that further define an angled edge 108, and a floor member 110. The side walls 106 may also be straight and not curved depending on the system. The end of the coiled spring may also snap-fit into the floor 110 or otherwise attached to the tray using any of the techniques described herein. One of skill in the art will readily appreciate that there are numerous shapes and configurations possible for the product-retaining member 44 and that the depicted configurations are merely exemplary embodiments of these numerous configurations.

**[0030]** Referring back to Figure 1, the exemplary trackless pusher mechanism 14 defines a pusher paddle 50 and a pusher floor 52. The pusher paddle 50 and pusher floor 52 may be formed as a single, unitary structure or may be separate structures that are joined together using known techniques. In addition, the pusher paddle 50 and pusher floor 52 may be made of any known suitable plastic or metal material. The pusher paddle and pusher floor may be reinforced using any known reinforcing techniques.

**[0031]** In one aspect, the pusher paddle 50 forms a curved-shape pusher surface or face 54 that is configured to match the shape of the product to be merchandised, such as plastic bottles or cans containing a beverage, as depicted in Figures 3-5. The curve-shaped pusher surface 54 permits the pusher to remain centrally aligned with the last product in the tray. This configuration reduces friction and drag between the pusher and the divider walls. In an alternative aspect, the pusher surface or face may be a flat surface. In yet another aspect, the flat pusher surface may be accompanied by a curved shaped rib that is positioned near or on the top of the pusher paddle and that may be used to center and align product in the tray, in a manner similar to the curve-shaped pusher surface 54 depicted in Figure 1. The curve shaped rib may define other shapes and configurations that permit cylindrical or similar shaped products to be properly pushed in the tray. Advertisement, product identification or other product information may be placed on the pusher surface 54.

**[0032]** Positioned behind the pusher surface or face 54 may be one or more support members 58, such as ribs, walls, or gussets. The support members 58 are configured to support the pusher surface 54 and further connect the pusher paddle 50 to the pusher floor 52. As can

be seen in Figure 5, positioned between the support members 58 is the coiled spring 30, and more specifically the coiled end 57 that is used to urge the pusher paddle 50 forward and along the tray 12, as understood in the art. Any technique used to operatively connect the coiled spring to the pusher paddle 50 may be used with the invention.

**[0033]** As shown in Figure 1, the pusher floor 52 may be positioned below the pusher paddle 50 and may extend forward of the pusher surface 54 of the pusher paddle. The pusher floor 52 may extend any predetermined distance and at any predetermined angle. For example, the pusher floor 52 may extend substantially perpendicular to the pusher surface 54. In the exemplary embodiment, the pusher floor 52 may extend a sufficient distance to permit one product, such as a single bottle or can, to be placed on the pusher floor. In another aspect, the pusher floor 52 may be configured to permit more than one product to be placed on the pusher floor. The pusher floor 52 may define any shape, including the depicted round shape and may define any product retaining features on the surface of the pusher floor, such as ribs, walls, or the like, to further hold the product on the pusher floor.

**[0034]** As can be seen in Figure 2, the pusher floor 52 may define an elongated channel, groove or recessed portion 59 that is sized, shaped and configured to seat the coiled spring 30. In the exemplary embodiment, the channel or groove 59 may extend across the floor 52 and in a substantially perpendicular manner relative to the pusher paddle 50. In an alternative aspect, the groove or channel may extend part-way or across the entire pusher floor 52, as shown in Figure 19. Such configuration permits the proper alignment and positioning of the pusher paddle 50 in the tray. The groove 59 may define a depth that matches or exceeds the thickness of the coiled spring 30. With this configuration, the coiled spring 30 will seat at or below the pusher floor surface such that product will not sit directly on the coiled spring, rather, such product will sit on the pusher floor surface. As shown in Figure 19, the pusher floor may include apertures and openings through which debris or other items may pass. Alternatively, the floor may be a solid surface.

**[0035]** In an alternative aspect of the invention, as shown in Figures 16-20, an adaptor 180 may be positioned on the surface 16. Referring to Figures 16 and 17, the adaptor 180 may include one or more raised ribs 182 on which a product may sit. The raised ribs 182 may extend longitudinally along the length of the adaptor 180. The adaptor 180 may be a flat extrusion of plastic material (or any other suitable material) defining a planar surface 184 with the one or more ribs 182 extending outwardly from the planar surface 184. The adaptor 180 may define a rounded end 185 and include a notch or cut-away portion 186 through which or across which the coiled spring may extend. The rounded end 185 may be configured to match the shape of the product that is placed on the tray. Other shapes of the end 185, notch 186 and adaptor 180

may be used with the invention depending on the product to be merchandised. The adaptor 180 may be a separate, insertable piece or, alternatively, a piece formed integral with the surface 16.

**[0036]** Referring to Figure 18, the adaptor 180 may be easily insertable onto the surface 16 and between the dividers 18. Referring to Figure 19, once the adaptor 180 is installed, the pusher mechanism 14 may be positioned on top of the adaptor 180 and may slide freely across the ribs 182 of the adaptor 180. The coiled spring 30 may extend in a parallel manner between the ribs 182 and may seat at or below the top surface of the ribs 182, as more clearly shown in Figure 20. With this configuration, the product to be merchandised may sit on, and slide along, the ribs 182 and not on the coiled spring 30.

**[0037]** In an alternative aspect, the ribs 182 may be a raised bead or raised beads, or a series of fingers that may be used to facilitate the movement of the product on the surface 16. In yet another alternative embodiment, the ribs 182 may be product moving members, such as runners or one or more rollers or rolling members that permit the product to roll across the rolling members and toward the front of the product display system. Exemplary roller assemblies include those disclosed and described in United States Application Serial No. 11/257,718 filed October 25, 2005 and assigned to RTC Industries, Inc, which application is incorporated herein by reference. As should be appreciated by those skilled in the art, there are many possible techniques that may be used with the described pusher mechanisms for facilitating the movement of the product on the shelf or floor.

**[0038]** The underneath side of the pusher floor 52 may be a smooth planar surface that will slide freely along the surface 16. Alternatively, and similar to above, the pusher floor 52 may include beads, runners, rollers or the like that will permit the pusher floor to slide along the surface yet raise the pusher floor up off of the surface 16. In another alternative embodiment, the underneath side of the pusher floor may be configured with rail mounting members to permit the mounting of the pusher to a track or rail, as understood in the art.

**[0039]** The pusher floor further defines a notch or cut-out portion 62 through which will pass the coiled spring 30. The end 29 of the coiled spring 30 will pass through the notch 62 and through the notch 26 of the surface 16 and will mount to the tray using any of the techniques described above.

**[0040]** In use, as the pusher mechanism 14 is urged rearward in the tray 12, the end 29 of the coiled spring 30 will be held in position as described above and the coiled end 57 of the spring 30 will begin to uncoil behind the pusher paddle 50. If the pusher 14 is allowed to move forward in the tray 14, such as when product is removed from the front of the tray, the coiled end 57 of the spring 30 will coil and force the pusher paddle 50 forward in the tray 12, thereby urging product toward the front of the tray.

**[0041]** In an alternative embodiment, the coiled spring

30 may extend below and underneath the pusher floor 52 as opposed to above and across the pusher floor, as depicted in the figures. With this configuration, the groove 59 and notch 62 may not be necessary.

**[0042]** The coiled spring 30 may be any biasing element including, without limitation, a flat coil spring commonly used with pusher systems. The present invention may use one or more coiled springs to urge the pusher mechanism 14 forward depending on the desired application. The coil tension of the spring 30 may also vary depending on the particular application.

**[0043]** Referring to Figure 2, the trackless pusher mechanism 14 is shown mounted to the tray 12. As illustrated, the pusher mechanism 14 fits in the tray 12 between the dividers 18. End 29 of the coiled spring 30 extends through the notch in the pusher floor and mounts to the tray as described above. In use, the pusher mechanism 14 will slide along the surface 16 of the tray 12 without the use of tracks, rails, or guides. As depicted in Figure 2, the pusher mechanism 14 is shown in a forward position.

**[0044]** Referring to Figure 3, the pusher mechanism 14 is shown merchandising one product 70 in the merchandise system 10. The product is prevented from tipping out of the tray by the product-retaining member 44. The product 70 may be any product to be merchandised including the depicted soft drink bottle. As shown in this Figure, the product 70 sits on the pusher floor 52 and the coiled spring 30 that extends below the product. The weight of the product on the floor 52 and the positioning of the product across the spring 30 prevent the paddle 50 from tipping in the tray 12.

**[0045]** Referring to Figure 4, the pusher mechanism 14 is shown merchandising multiple products 70 in the merchandise system 10. As shown in this Figure, the product next to the pusher paddle 50 sits on the pusher floor 52 and the coiled spring 30 that extends below the product. The other products will sit on the coiled spring 30 that will extend below these products. Alternatively, the adaptor 180 may be positioned in the system in which case the product may sit on the ribs 182 of the adaptor as opposed to the coiled spring. Again, the weight of the product on the pusher floor 52 and the positioning of the products across the spring 30 prevent the paddle 50 from tipping in the tray. In use, as one product is removed from the front of the tray near the product-retaining member 44, the pusher mechanism 14 (through the urging of the coiled spring 30) will push the remaining product forward in the tray 12 until the forward-most product contacts the product-retaining member 44. As additional products are removed, the pusher mechanism 14 will continue to push the remaining product toward the product-retaining member 44.

**[0046]** Referring to Figure 5, a rear view of the pusher mechanism 14 shows the pusher mechanism 14 merchandising multiple products 70 in the merchandise system 10. Again, the product next to the pusher paddle 50 sits on the pusher floor 52 and the coiled spring 30 that

extends below the product. The other products will sit on the coiled spring that will extend below these products. Alternatively, the adaptor 180 may be positioned in the system in which case the product may sit on the ribs 182 of the adaptor as opposed to the coiled spring. As one product is removed from the front of the tray near the product-retaining member 44, the coiled end 57 of the spring 30 will urge the pusher paddle 50 of the pusher mechanism 14 forward in the tray 12 until the forward-most product contacts the product-retaining member 44. As can be seen in this Figure, the coiled end 57 may be positioned between two support members 58. The support members will retain the coiled spring between these members. As can be seen in this Figure, the pusher floor 52 may also extend below the support members 58.

**[0047]** Referring to Figure 6, an alternative embodiment of the pusher tray is depicted. With this embodiment, multiple trays 12 may be formed into a single multi-tray assembly 80. The multi-trays may have a common floor with dividers 18 extending upwardly from the floor to create the multiple trays or rows. In this embodiment, the product-retaining member 44 may be a solid member that extends between two dividers, as discussed above. One or more of the multi-tray assemblies 80 may be coupled or joined together in a side-by-side manner using any known technique, including clips, dovetailing, fasteners, or the like. With this configuration, numerous rows of product can be provided for the merchandising of numerous products.

**[0048]** As stated above, the trackless pusher mechanism 14 may be used with gravity-fed systems, that is, systems having trays or product channels that are mounted on an incline to permit gravity to assist with the merchandising of the product. Alternatively, the trackless pusher mechanism 14 may be used with systems that are mounted in a non-inclined or in a horizontal manner where gravity will provide little or no assistance with the merchandising of the product. The trackless pusher mechanism 14 may also be used to push various shaped products.

**[0049]** Figure 7 depicts an exemplary tip 60 for the end 29 of a coiled spring 30 that may be used with the merchandise system 10. As illustrated, the tip 60 defines an aperture 61 for receiving the end 29 of the coiled spring and an aperture 63 for mounting to the surface 16 of the tray. As can be seen in Figure 7, in one aspect of an alternative embodiment, extending beneath the surface 16 may be a tongue or mounting member 65 that may be configured to mate with the aperture 63 and to snap-fit the tip 60 onto the tongue 65 and thus to the surface 16.

**[0050]** Referring to Figure 8, the exemplary tip 60 of Figure 7 is shown being mounted to the tongue or mounting member 65. The tongue 65 may include an elongated outwardly extending rib 67 that is used to snap-fit the tip 60 onto the tongue 65. One skilled in the art will appreciate that other techniques may be used to mount the tip 60 to the surface 16 and that the depicted technique is merely an exemplary embodiment of one such technique.

**[0051]** Referring to Figure 9, the exemplary tip 60 is shown fully mounted in a snap-fit manner to the surface 16, and more specifically to the end portion 24 of the surface 16 of the tray 12. Also depicted is the mounting of the end 29 of the coiled spring 30 to the aperture 61 of the tip 60. As shown in Figure 9, the end 29 of the coiled spring may be inserted into the aperture 61. The aperture 61 is configured to receive the end 29 of the coiled spring and hold the end 29 in position, and to also permit the removal of the end 29 of the coiled spring from the aperture 61 in those circumstances where it is desirable to disconnect the coiled spring from the tip to permit the removal of the pusher mechanism 14 from the system.

**[0052]** Referring to Figure 10 there is shown the end 29 of the coiled spring fully mounted to the exemplary tip 60. As illustrated in this figure, the coiled spring 30 is now operatively connected to the surface 16 of the tray 12. As a result, the pusher mechanism 14 is now mounted to the tray 12.

**[0053]** Referring to Figures 21-27 there is shown an alternative technique for mounting the end 29 of the coiled spring 30 to the merchandise display system. A mounting member 130 may be used to mount the end 29 of the coiled spring to the floor 131 of the system. For those systems that include spaced-apart glide rails 132 that are joined together by connecting ribs 134 (Figures 26-27), the mounting member 130 may be snap-fit to or otherwise mounted on the floor 131 and between the glide rails 132. The mounting member will thus hold the end of the coiled spring in position and to the floor of the system.

**[0054]** Referring to Figures 22-23, the mounting member 130 may include one or more legs 136 on one or more sides of the member 130. The legs may be configured to snap-fit to the underside of the rails 132 to thereby hold the mounting member 130 to the floor of the system. The legs 136 may include legs ends 137 defining an L-shape or angled surfaces that are configured to contact the underside of the rail 132 and prevent the mounting member 130 from being lifted up from the floor, except by the intentional flexing of the legs out from the underside of the rail 132. The legs 136 may contact the connecting ribs 134 which will prevent slidable movement of the mounting member 130 relative to the floor. Referring to Figure 26, the mounting member 130 is shown being mounted to the floor of the system and more specifically to the rails. Figure 27 illustrates that the mounting member 130 remains in position as the pusher paddle 141 is pulled away from the front of the system. The mounting member 130 may be connected to this type of system floor 131 using other techniques. For example, a separate mounting clip, one or more fasteners, adhesives, or other techniques may be used to secure the mounting member 130 to the floor 131.

**[0055]** Referring to Figures 22-23, the mounting member 130 may also include an aperture or opening or slot 138 that will receive the end 29 of the spring. The spring

may be mounted using any of the techniques described herein, or other techniques. The configuration of the aperture 138 and mounting member 130 will hold the spring in position on the mounting member 130, similar to the technique described above.

**[0056]** The mounting member 130 may also include glide ribs 139 on a top surface that allow product placed thereon to slide more easily across the mounting member after the mounting member is installed to the floor of the system. The mounting member 130 may also include an elongated flat body 140 that extends forward of the location of the legs 136 to provide stability to the mounting member 130 after it is mounted to the floor of the system.

**[0057]** Referring to Figures 24-25 and 27, the pusher paddle or pusher mechanism 141 may include a pusher face 143 configured to match the shape of the product against which it pushes. As illustrated, the pusher face 143 may be curve shaped to match the shape of a bottle or other cylindrical object. The pusher paddle 141 may also include a pusher floor 145 similar to the pusher floor configurations described above. The pusher floor 145 may further include a spring sleeve 147 that receives the coiled spring 30 to shield and protect the spring. The spring sleeve 147 may extend partly or fully across the pusher floor 145 and in the direction of the spring 30. The spring sleeve 147 may have a relatively short height and a flat surface 149 to permit product to sit thereon without significant tipping or leaning of the product.

**[0058]** The pusher paddle 141 may be positioned on top of the floor 131 to glide on top of the surface, as describe above. The pusher paddle may be positioned between two product divider walls 153 that are joined together by a product retaining member 155. Additional product retaining members 157 may extend outwardly from the product dividers.

**[0059]** Referring to Figures 28 and 29 there is shown yet another alternative technique for mounting the end 29 of the coiled spring 30 to the merchandise display system. In this embodiment, the end 29 is riveted to the tray 216.

**[0060]** Referring to Figures 28-32 in an alternative embodiment, the trackless pusher system may be retrofitted to an existing shelf assembly 230, which may have product dividers already built in. For example, in one embodiment, the trackless pusher system may be retrofitted to an existing wire shelf assembly. Referring to Figures 30-32, a tray or adaptor 216 may have a glide floor 222 that may be sized to a single lane of the shelf 234 or sized to an entire shelf width. The glide floor 222 may include several raised ribs 224, which help to reduce friction for the products merchandised on the tray 216. It should be understood that one or more raised ribs 224 may be used with the glide floor 222. Alternatively, the glide floor 222 may be a flat, planar surface without raised ribs. The tray or adaptor 216 may be configured similar to the adaptor 180 of Figure 16.

**[0061]** As shown in Figures 28 and 30, the end 29 of coiled spring 30 may be riveted, via a rivet 229, to the

front end 228 of the tray 216, or may be attached by any other attachment technique. The tray 216 can be retained to the shelf by any attachment technique suitable for the particular shelf. In one embodiment, and as illustrated in Figures 29-32, the tray 216 may include one or more outwardly extending fingers or snaps 220, which may engage one or more individual wires 232 of the shelf 234 to retain the tray 216 on the shelf 234. The fingers or snaps 220 may extend longitudinally along the length of the tray 216, or may be spaced apart along the length of the tray. The snaps 220 may be used to snap-fit the tray 216 to the existing wire shelf. As depicted in Figures 29A and 29B, the snaps 220A and 220B may define numerous configurations that permit the tray 216 to be snap fit to the shelf. The embodiment depicted in Figures 28-32 allows for the placement of the trackless pusher system in an existing shelving system, such as a wire shelf system, as a low cost alternative to the entire trackless pusher assembly. It should be understood that with this embodiment, any pusher mechanism described herein may be used.

**[0062]** As depicted in FIGS. 33 and 44, in another exemplary embodiment, the display management system comprises one or more pusher mechanisms 286, one or more dividers 266, one or more trays 306, and one or more retainers 250. The pusher mechanisms 286 can be formed of a pusher paddle 287 and a pusher floor 288. Product is placed on the pusher floor 288 and guided to the front of the display management system via the dividers 266 and the pusher paddle 287. The coiled spring 30 biases the pusher mechanism 286 toward the retainer 250 such that product moves to the front of the system.

**[0063]** In one exemplary embodiment, depicted in FIG. 33, the coiled spring 30 can be mounted to the retainer 250. Alternatively, the coiled spring 30 can be mounted to a divider 266 (also shown in FIGS. 48 and 49). The coiled spring 30 can be directly mounted to the retainer 250, as depicted in FIG. 33, or can be mounted to the retainer 250 via a separate adapter 252, as depicted in FIG. 34.

**[0064]** As depicted in FIG. 35, the adapter 252 has a wall 254 proximate a first end 256. The first end 256 has a curved portion 262, which curves upwardly. The middle portion of the adapter 252 may be provided with a curved slot 260, which is adapted to receive a correspondingly shaped spring end (not shown).

**[0065]** The coiled spring 30 at one end can be secured to the middle portion of the adapter 252. In an exemplary embodiment, the curved slot 260 corresponds in shape and size of the first spring end. Additionally, the first spring end of the coiled spring 30 can be crimped or bent to provide for additional fastening. Nevertheless, any sufficient fastening method can be used to fix the first spring end of the coiled spring 30 to the adapter 252.

**[0066]** In an exemplary embodiment, shown in FIGS. 36 and 37, the retainer 250 has a curved slot 284 corresponding in shape and size to the curved portion 262 of the adapter 252. The curved slot 284 extends the length

of the retainer to allow for unlimited positioning of the adapter 252 along the length of the retainer 250.

**[0067]** To secure the first spring end of the coiled spring 30 to the retainer 250, the curved portion 262 of the adapter 252 is placed into the curved slot 284 of the retainer 250. The curved slot 284 secures the adapter 252 and the first spring end of the coiled spring 30 to the retainer 250 and provides for a quick and easy assembly of the display system. The wall 254 provides additional stability in the connection between the retainer 250 and the adapter 252. Other methods, however, can be used to secure the adapter 252 and/or the first spring end of the coiled spring 30 to the retainer 250.

**[0068]** Alternatively, as depicted in FIGS. 33 and 44 the coiled spring 30 of the pusher paddle 287 can be mounted directly to the front of the tray 306. The first spring end 290 of the coiled spring 30 is provided with a curved portion. The curved portion curves downwardly from the pusher floor 288 and is adapted to be received in a recess 316 (shown in FIG. 33) defined by a lip 318 of the front surface of the dispensing tray 306 and the retainer 250. A vertically oriented surface of the retainer 250 and the lip 318 are spaced such that a gap is formed between the vertically oriented surface and a front edge of the lip 250. To secure the coiled spring 30 and the pusher mechanism 286 to the assembly, the first spring end 290 is inserted into the gap formed between the vertically oriented surface of the retainer 250 and the front edge of the lip 318 and placed into the recess 316 formed by the lip 318 of the dispensing tray 306 and the retainer 250.

**[0069]** In another exemplary embodiment depicted in FIGS. 38, 39, 48 and 49, the coiled spring 30 can be directly mounted to a divider 266. In addition, in this exemplary embodiment the coiled spring 30 can be mounted perpendicular to the pusher floor 288 such that the axis, about which the coiled spring 30 is coiled, is perpendicular to the pusher floor 288. This orientation has the benefit of preventing the pusher paddle from tipping back. The first spring end 290 can be provided with an angled portion 292 and a tip portion 296. In one exemplary embodiment, the angled portion 292 can be bent perpendicular to the coiled spring body 294. The divider can be provided with a slot 298, which is adapted to receive the tip portion 296 of the first spring end 290.

**[0070]** To secure the coiled spring to the divider, the tip portion 296 is inserted into the slot 298. Once the tip portion 296 is fully inserted into the slot 298, the angled portion 292 engages the slot 298 so as to secure the first spring end 290 to the divider 266.

**[0071]** As depicted in FIG. 33, various pusher mechanism designs can be implemented. The pusher paddle 287 can be formed flat to accommodate correspondingly shaped product. Alternatively, the pusher paddle 286 can have a curved first end and a flat second end. This serves to accommodate a variety of cylindrical products having a variety of different sized diameters and to facilitate the operation of the pusher mechanism 286. During opera-

tion, the product in the pusher mechanism 286 and the curved first end together force the pusher mechanism against the divider 266, such that the coil spring 30 remains flat against the divider 266 holding the first spring end 290, while in tension or in operation. This allows for a smoother operation of the pusher mechanism and ensures that the product is properly dispensed as users remove the product from the system.

**[0072]** In another exemplary embodiment depicted in FIGS. 40-41D, the distance between the dividers 266 can be adjusted to accommodate different sized containers. The dividers 266 can be provided with connecting portions 272. The connecting portions 272 can be provided with a first elongated angled surface 268 and a second elongated angled surface 270. Additionally, the connecting portions 272 can be provided with a plurality of projections 274. As depicted in FIG. 41B, the rails can be formed of teeth 278 having face surfaces 280 and flank surfaces 282.

**[0073]** When assembled, as depicted in FIG. 41C, the connecting portions 272 are received between the teeth 278 of the rails. Additionally, the elongated angled surfaces 268 and 270 and the projections 274 are wedged between the teeth 278. Also as shown in FIG. 41C, the elongated angled surfaces 268 and 270 engage the face surfaces 280, and the projections 274 engage the lower surfaces of the teeth 278. Flank surfaces 282 contact the connecting portion 272.

**[0074]** In an exemplary embodiment depicted in FIG. 42, the trays 306 are provided with dovetail connections. A first side 308 of the trays 306 is provided with tongues 312 adapted to fit within grooves 314 located on a second side 310 of the trays 306. To connect the trays, the grooves 314 are aligned with tongues 312 such that the tongues 312 are firmly secured within the grooves 314.

**[0075]** In an exemplary embodiment depicted in FIG. 43, the trays 306 are configured to receive the retainer 250 at a front end. The retainer can be provided with rectangular holes 300, and the retainer is provided with correspondingly shaped and sized projections 302. To secure the retainer 250 to the tray 306, the projections 302 fit into holes 300 to lock the retainer into place on the tray 306.

**[0076]** As depicted in FIGS. 45-47, after the product management display system is assembled, product is loaded into the system. By adjusting the dividers 266 a wide variety of product sizes and shapes can be loaded into the system. As shown in FIGS. 46 and 47, the coil spring 30 in conjunction with the pusher paddle 287 push the product toward the retainer 250. As a user takes product out of the system, the pusher paddle 287 pushes the remaining product such that the product slides along the floor 264 to the retainer 250. This assures that all product remains at the front of the display system.

**[0077]** As depicted in Figures 50-52, the product management display system 400 can be arranged such that trays 402, 404 can be stacked on top of one another. This embodiment can consist generally of a first tray 402,

a second tray 404, a first spacer 406, and a second spacer 408.

**[0078]** The trays 402, 404 are each arranged to house product to be dispensed. The first tray 402 and the second tray 404 can be each provided with a clear retainer 410, a pusher mechanism 412, first and second guiding walls, and a coil spring 414.

**[0079]** The pusher mechanism 414 is arranged in a similar fashion as the embodiments discussed above, such that it slides product along the surface of the trays 402, 404, while product is removed. Additionally, any of the alternative arrangements of the pusher mechanism discussed above may be implemented in a stackable tray arrangement.

**[0080]** To provide for an easy assembly and disassembly, the stackable product management display system can be provided with a dovetail connection or any other suitable connection, such as a snap-fit connection, screw-thread connection, or a rivet connection. The first and second trays are provided with detents 416 for assembling the first and second spacers 406, 408 to the first and second trays 402, 404. Each of the first and second trays 402, 404 can be provided with sockets 418 on their respective outside surfaces for receiving the correspondingly shaped detents 416 located on the first and second spacers 406, 408.

**[0081]** To assemble the stackable product management display system, the detents 416 located on the first and second spacers 406, 408 are placed into the correspondingly shaped sockets 418 on the outside surfaces of the first and second trays 402, 404 in a locking arrangement. This provides for a stackable arrangement that can be implemented in conjunction with any of the embodiments discussed above.

**[0082]** Variations and modifications of the foregoing are within the scope of the present invention. For example, one of skill in the art will understand that multiples of the described components may be used in stores and in various configurations. The present invention is therefore not to be limited to the single system 10, nor the upright pusher configuration, depicted in the Figures, as the system 10 is simply illustrative of the features, teachings and principles of the invention. It should further be understood that the invention disclosed and defined herein extends to all alternative combinations of two or more of the individual features mentioned or evident from the text and/or drawings. All of these different combinations constitute various alternative aspects of the present invention. The embodiments described herein explain the best modes known for practicing the invention and will enable others skilled in the art to utilize the invention. The claims are to be construed to include alternative embodiments to the extent permitted by the prior art.

**[0083]** Various features of the invention are set forth in the following claims.

**Claims****1.** A product management display system:

a first tray (402) and a second tray (404) each having a first wall and a second wall, the first (402) and second (404) tray each adapted to receive a pusher mechanism (412), and a retainer mechanism (410);

a plurality of spacers (406, 408) mountable to the first and second trays (402, 404) for stacking the first tray (402) above the second tray (404) wherein each of the plurality of spacers (406, 408) further comprise a plurality of detents (416), the first tray (402) and the second tray (404) each having a plurality of correspondingly shaped sockets (418) on an outer surface, wherein each of the plurality of sockets (418) is configured to receive one of the plurality of detents (416) **characterized by** the retainer mechanism (410) being attached to a front portion of the tray and including a floor and a two curved sidewalls.

**2.** The product management display system of claim 1, wherein one or more of the plurality of spacers (406, 408) are mounted to both the first wall of the first tray (402) and the first wall of the second tray (404).

**3.** The product management display system of claim 1 or claim 2, wherein one or more of the plurality of spacers (406, 408) are mounted to both the second wall of the first tray (402) and the second wall of the second tray (404).

**4.** The product management display system of any one of claims 1 to 3, and provided with a dovetail connection.

**5.** The product management display system of any one of claims 1 to 3, wherein the plurality of spacers (406, 408) have a snap fit connection with the first and second tray (402, 404).

**6.** The product management display system of any one of claims 1 to 3, wherein the plurality of spacers (406, 408) are secured to the first and second tray (402, 404) by screw thread or rivet connection.

**7.** The product management display system of any one of the preceding claims, wherein each of the first and second tray (402, 404) has a pusher mechanism (412) the pusher mechanism (412) comprising a coiled spring (414) configured to urge the pusher mechanism (412) toward a front portion of the first tray (402) or the second tray (404).

**8.** The product management display system of claim 7, wherein the coil spring (414) has a first spring end (290) having an angled portion (292) and a tip portion (296).

**9.** The product management display system of claim 7 or claim 8, wherein the pusher mechanism (412) has a pusher surface and a pusher floor, the pusher floor extending forwardly from the pusher surface.

**10.** The product management display system of claim 9, wherein the pusher floor includes a channel extending across at least a portion of the pusher floor that receives the coiled spring (414) to permit proper alignment and positioning of the pusher mechanism in the tray.

**11.** The product management display system of claim 9 or claim 10, wherein the product is configured to sit on the pusher floor and the product is configured to sit on the coiled spring such that weight of the product on the pusher floor and the coiled spring prevent the pusher mechanism from tipping in the tray.

**12.** The product management display system of any one of claims 9 to 11, further comprising a plurality of support members that are configured to support the pusher surface and connect the pusher surface to the pusher floor, and wherein the coiled spring is positioned between the plurality of support members.

**13.** The product management display system of any one of claims 9 to 12, wherein the pusher surface includes a curved shaped rib on a top portion of the pusher surface to center and align product in the tray.

**14.** The product management display system of any one of the preceding claims, wherein the retainer mechanism (410) is transparent.

**15.** The product management display system of any one of the preceding claims, wherein the first tray (402) and second tray (404) have a surface that has a plurality of spaced-apart apertures (20) separated by a plurality of support ribs (22) to permit liquid and dirt to pass through.

**50 Patentansprüche****1.** Produktmanagement-Auslegesystem:

eine erste Ablage (402) und eine zweite Ablage (404), wovon jede eine erste Wand und eine zweite Wand aufweist, wobei sowohl die erste (402) als auch die zweite (404) Ablage ausgelegt sind, um einen Schiebermechanismus

- (412) und einen Haltemechanismus (410) aufzunehmen;  
mehrere Abstandshalter (406, 408), die an der ersten und zweiten Ablage (402, 404) montiert sein können, um die erste Ablage (402) oberhalb der zweiten Ablage (404) zu stapeln, wobei jeder der mehreren Abstandshalter (406, 408) ferner mehrere Zapfen (416) umfasst und die erste Ablage (402) und die zweite Ablage (404) auf einer äußeren Oberfläche jeweils mehrere entsprechend geformte Buchsen (418) aufweisen, wobei jede der mehreren Buchsen (418) konfiguriert ist, um einen der mehreren Zapfen (416) aufzunehmen, **dadurch gekennzeichnet, dass** der Haltemechanismus (410) an einem vorderen Abschnitt der Ablage befestigt ist und einen Boden und zwei gekrümmte Seitenwände aufweist.
2. Produktmanagement-Auslagesystem nach Anspruch 1, wobei einer oder mehrere der mehreren Abstandshalter (406, 408) sowohl an die erste Wand der ersten Ablage (402) als auch an die erste Wand der zweiten Ablage (404) montiert sind.
  3. Produktmanagement-Auslagesystem nach Anspruch 1 oder Anspruch 2, wobei einer oder mehrere der mehreren Abstandshalter (406, 408) sowohl an die zweite Wand der ersten Ablage (402) als auch an die zweite Wand der zweiten Ablage (404) montiert sind.
  4. Produktmanagement-Auslagesystem nach einem der Ansprüche 1 bis 3 und versehen mit einer Schwalbenschwanzverbindung.
  5. Produktmanagement-Auslagesystem nach einem der Ansprüche 1 bis 3, wobei die mehreren Abstandshalter (406, 408) eine Schnappverbindung mit der ersten und zweiten Ablage (402, 404) aufweisen.
  6. Produktmanagement-Auslagesystem nach einem der Ansprüche 1 bis 3, wobei die mehreren Abstandshalter (406, 408) an der ersten und zweiten Ablage (402, 404) durch eine Schraubgewinde- oder Nietverbindung befestigt sind.
  7. Produktmanagement-Auslagesystem nach einem der vorhergehenden Ansprüche, wobei sowohl die erste als auch die zweite Ablage (402, 404) einen Schiebermechanismus (412) aufweist, wobei der Schiebermechanismus (412) eine Schraubenfeder (414) umfasst, die konfiguriert ist, um den Schiebermechanismus (412) zu einem vorderen Abschnitt der ersten Ablage (402) oder der zweiten Ablage (404) zu drängen.
  8. Produktmanagement-Auslagesystem nach Anspruch 7, wobei die Schraubenfeder (414) ein erstes Federende (290) aufweist, das einen abgewinkelten Abschnitt (292) und einen Spitzenabschnitt (296) aufweist.
  9. Produktmanagement-Auslagesystem nach Anspruch 7 oder Anspruch 8, wobei der Schiebermechanismus (412) eine Schieberoberfläche und einen Schieberboden aufweist, wobei sich der Schieberboden von der Schieberoberfläche nach vorne erstreckt.
  10. Produktmanagement-Auslagesystem nach Anspruch 9, wobei der Schieberboden einen Kanal enthält, der sich über wenigstens einen Abschnitt des Schieberbodens erstreckt und der die Schraubenfeder (414) aufnimmt, um eine korrekte Ausrichtung und Positionierung des Schiebermechanismus in der Ablage zu ermöglichen.
  11. Produktmanagement-Auslagesystem nach Anspruch 9 oder Anspruch 10, wobei das Produkt konfiguriert ist, um auf dem Schieberboden aufzusitzen, und das Produkt konfiguriert ist, um auf der Schraubenfeder aufzusitzen, so dass das Gewicht des Produkts auf dem Schieberboden und der Schraubenfeder verhindert, dass der Schiebermechanismus in die Ablage kippt.
  12. Produktmanagement-Auslagesystem nach einem der Ansprüche 9 bis 11, das ferner mehrere Stützelemente umfasst, die konfiguriert sind, um die Schieberoberfläche zu stützen und die Schieberoberfläche mit dem Schieberboden zu verbinden, und wobei die Schraubenfeder zwischen den mehreren Stützelementen positioniert ist.
  13. Produktmanagement-Auslagesystem nach einem der Ansprüche 9 bis 12, wobei die Schieberoberfläche einen gebogen geformten Steg enthält, um das Produkt in der Ablage zu zentrieren und auszurichten.
  14. Produktmanagement-Auslagesystem nach einem der vorhergehenden Ansprüche, wobei der Haltemechanismus (410) durchsichtig ist.
  15. Produktmanagement-Auslagesystem nach einem der vorhergehenden Ansprüche, wobei die erste Ablage (402) und die zweite Ablage (404) eine Oberfläche aufweisen, die mehrere beabstandete Öffnungen (20) aufweist, die durch mehrere Stützstege (22) getrennt sind, um zu ermöglichen, dass Flüssigkeit und Schmutz hindurchtreten.

## Revendications

### 1. Système d'affichage de gestion de produits :

un premier plateau (402) et un second plateau (404) présentant, chacun, une première paroi et une seconde paroi, le premier (402) et le second (404) plateaux étant conçus, chacun, pour recevoir un mécanisme de poussée (412) et un mécanisme de retenue (410) ;

une pluralité de dispositifs d'écartement (406, 408) pouvant être fixés sur le premier et le second plateaux (402, 404) dans le but d'empiler le premier plateau (402) au-dessus du second plateau (404), dans lequel chaque dispositif de la pluralité des dispositifs d'écartement (406, 408) comporte, de plus, une pluralité de positionneurs (416), le premier plateau (402) et le second plateau (404) comportant, chacun, une pluralité d'éléments de raccordement configurés de façon correspondante (418) sur une surface extérieure, dans lequel chaque logement de la pluralité de logements de raccordement (418) est configuré de façon à recevoir l'un de la pluralité des positionneurs (416), **caractérisé par** le mécanisme de retenue (410) qui est fixé à une partie avant du plateau et comportant un plancher et deux parois latérales courbes.

2. Système d'affichage de gestion de produits selon la revendication 1, dans lequel l'un ou plusieurs de la pluralité des dispositifs d'écartement (406, 408) sont fixés à la fois sur la première paroi du premier plateau (402) et sur la première paroi du second plateau (404).

3. Système d'affichage de gestion de produits selon la revendication 1 ou la revendication 2, dans lequel l'un ou plusieurs de la pluralité des dispositifs d'écartement (406, 408) sont fixés à la fois sur la seconde paroi du premier plateau (402) et sur la seconde paroi du second plateau (404).

4. Système d'affichage de gestion de produits selon l'une quelconque des revendications 1 à 3, et doté d'un raccordement à queue d'aronde.

5. Système d'affichage de gestion de produits selon l'une quelconque des revendications 1 à 3, dans lequel la pluralité des dispositifs d'écartement (406, 408) possède un raccordement à ajustement par encliquetage avec le premier et le second plateau (402, 404).

6. Système d'affichage de gestion de produits selon l'une quelconque des revendications 1 à 3, dans lequel la pluralité des dispositifs d'écartement (406, 408) est fixée aux premier et au second plateaux

(402, 404) par un filetage de vis ou un raccordement par rivet.

7. Système d'affichage de gestion de produits selon l'une quelconque des revendications précédentes, dans lequel chacun des premier et second plateaux (402, 404) possède un mécanisme de poussée (412), le mécanisme de poussée (412) comportant un ressort en spirale (414) configuré pour presser le mécanisme de poussée (412) vers une partie avant du premier plateau (402) ou du second plateau (404).

8. Système d'affichage de gestion de produits selon la revendication 7, dans lequel le ressort en spirale (414) présente une première extrémité de ressort (290) ayant une partie inclinée (292) et une partie de tête (296).

9. Système d'affichage de gestion de produits selon la revendication 7 ou la revendication 8, dans lequel le mécanisme de poussée (412) présente une surface de poussée et un plancher de pousoir, le plancher de pousoir s'étendant vers l'avant à partir de la surface de poussée.

10. Système d'affichage de gestion de produits selon la revendication 9, dans lequel le plancher de pousoir comporte une gorge s'étendant à travers au moins une partie du plancher de pousoir qui reçoit le ressort en spirale (414) afin de permettre un alignement et un positionnement corrects du mécanisme de poussée dans le plateau.

11. Système d'affichage de gestion de produits selon la revendication 9 ou la revendication 10, dans lequel le produit est configuré en vue d'être posé sur le plancher de pousoir et dans lequel le produit est configuré pour être posé sur le ressort en spirale de telle sorte que le poids du produit sur le plancher de pousoir et le ressort en spirale empêchent le mécanisme de poussée de chavirer dans le plateau.

12. Système d'affichage de gestion de produits selon l'une quelconque des revendications 9 à 11, comportant, de plus, une pluralité d'éléments de support qui sont configurés pour supporter la surface de poussée et raccorder la surface de poussée au plancher de pousoir, et dans lequel le ressort en spirale est positionné entre la pluralité d'éléments de support.

13. Système d'affichage de gestion de produits selon l'une quelconque des revendications 9 à 12, dans lequel la surface de poussée comporte une nervure de configuration incurvée sur une partie supérieure de la surface de poussée afin de centrer et d'aligner un produit dans le plateau.

14. Système d'affichage de gestion de produits selon l'une quelconque des revendications précédentes, dans lequel le mécanisme de retenue (410) est transparent.

5

15. Système d'affichage de gestion de produits selon l'une quelconque des revendications précédentes, dans lequel le premier plateau (402) et le second plateau (404) présentent une surface qui possède une pluralité d'ouvertures placées de façon espacée (20) séparées par une pluralité de nervures de support (22) pour permettre à un liquide et à la saleté de passer à travers.

10

15

20

25

30

35

40

45

50

55

FIG. 1

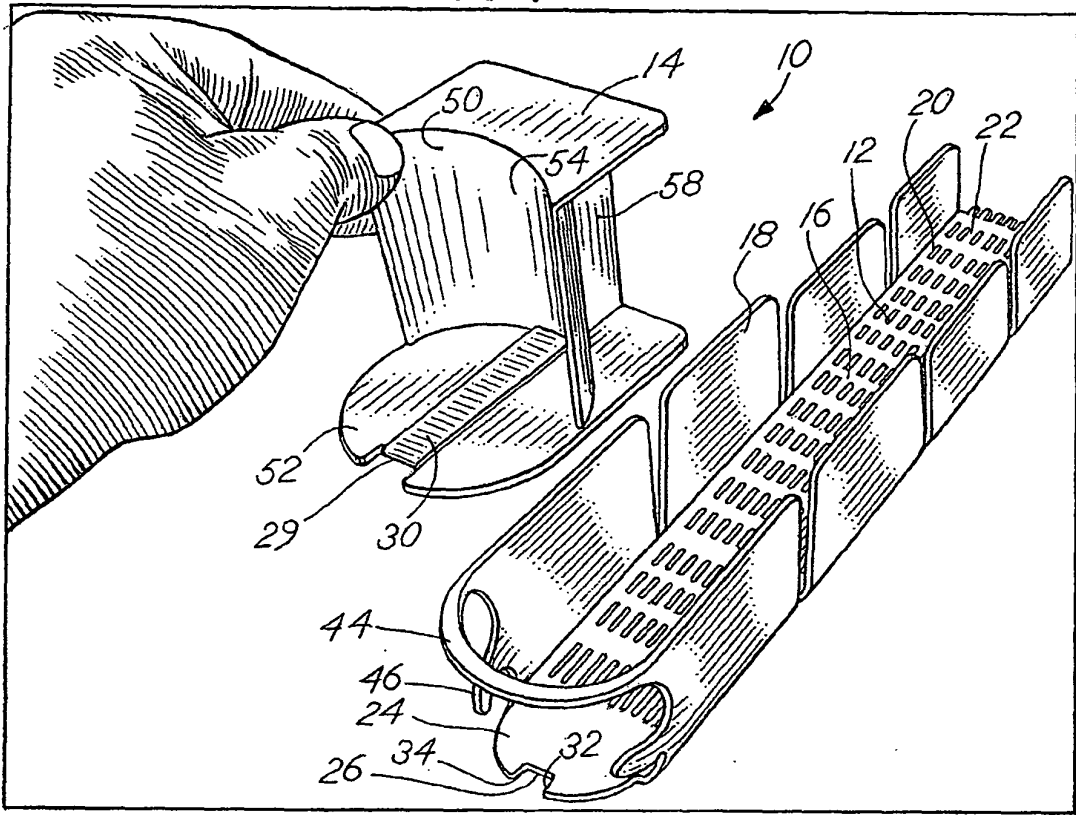
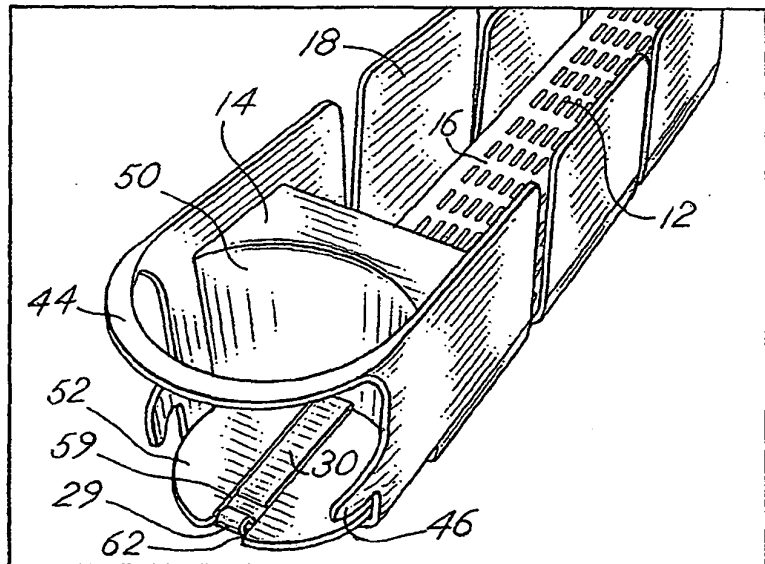
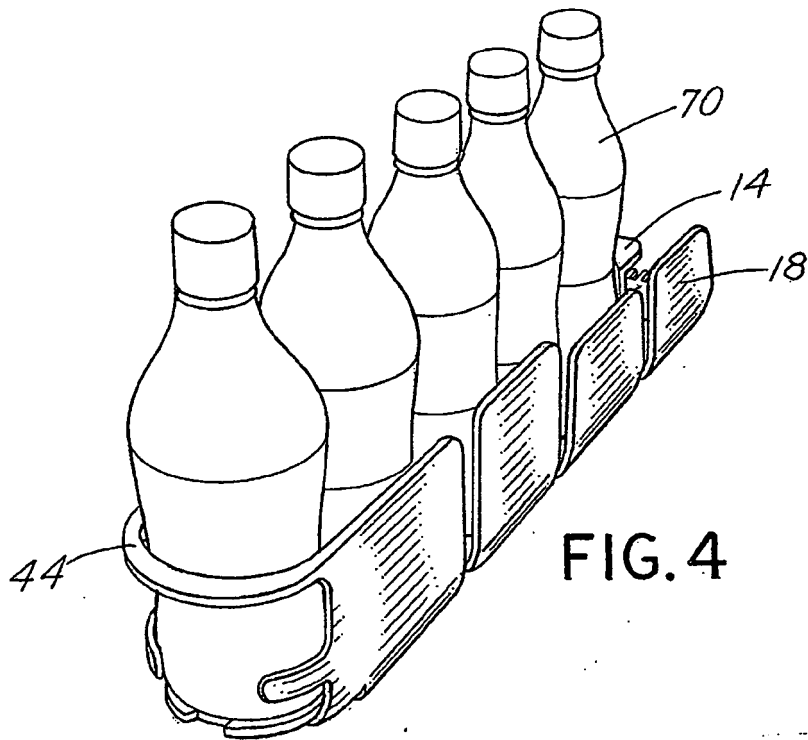
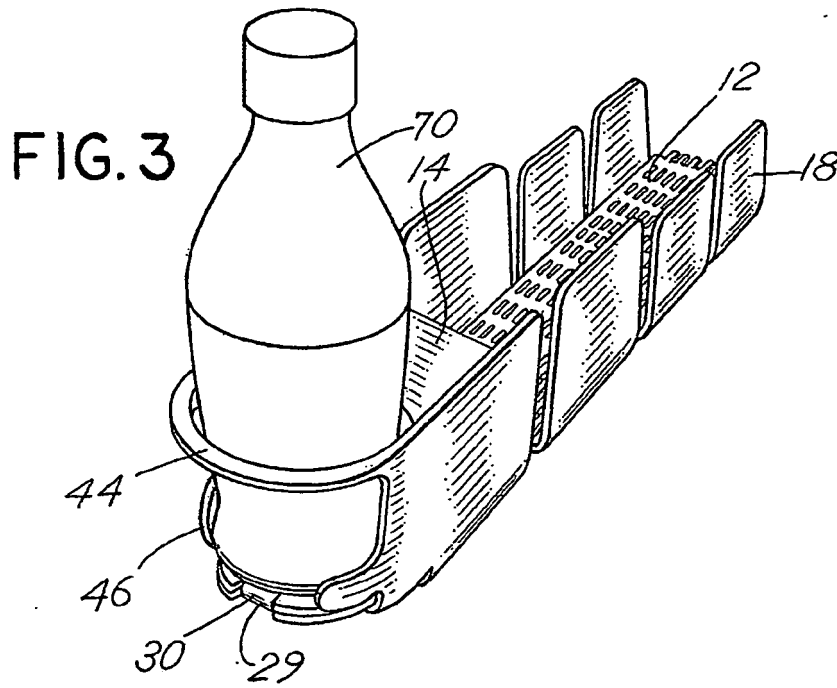

FIG. 2





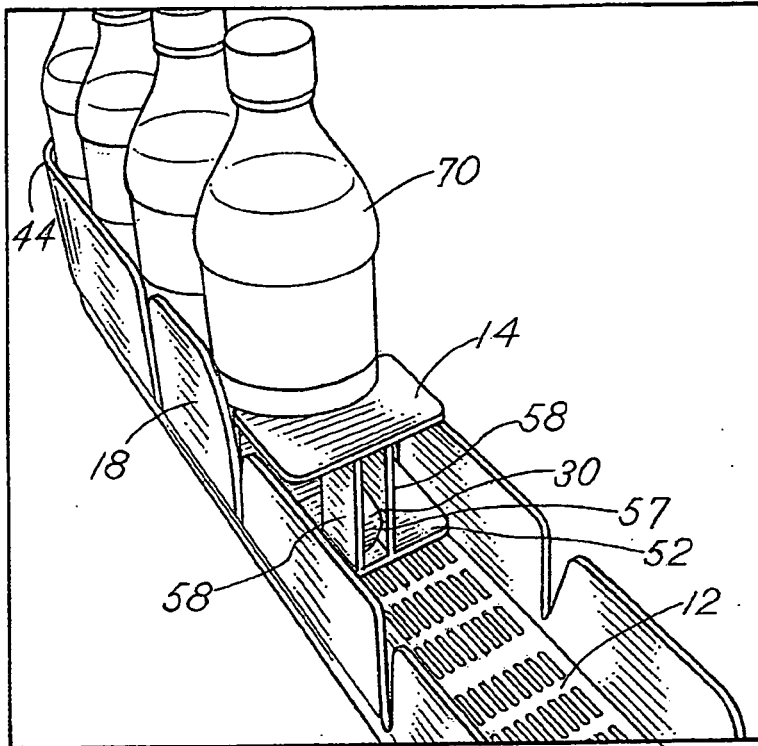

FIG. 5

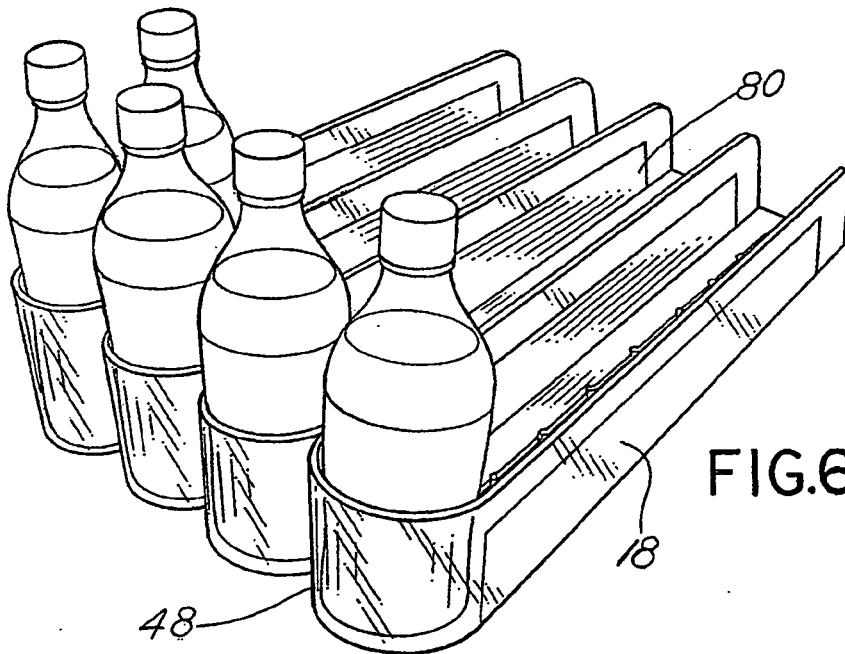

FIG. 6

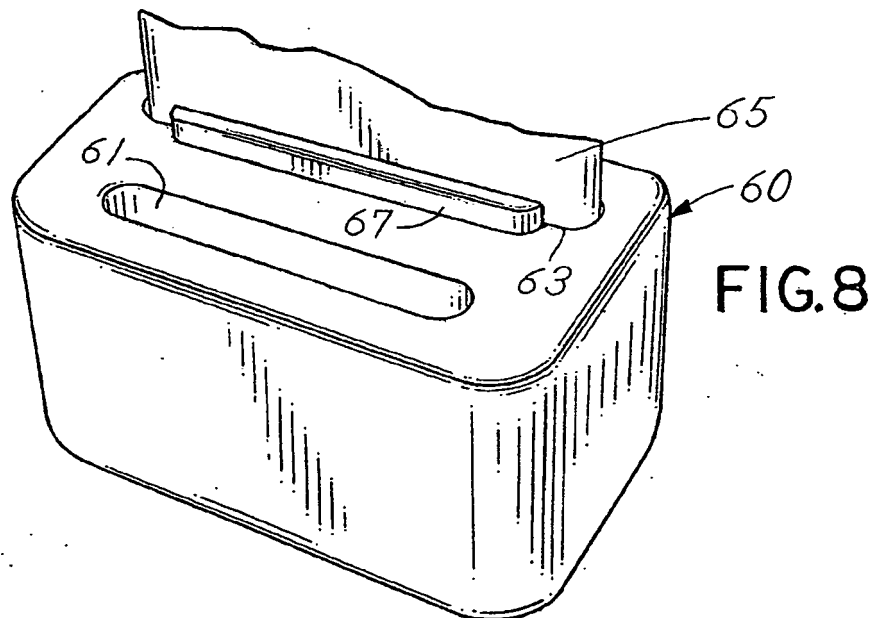
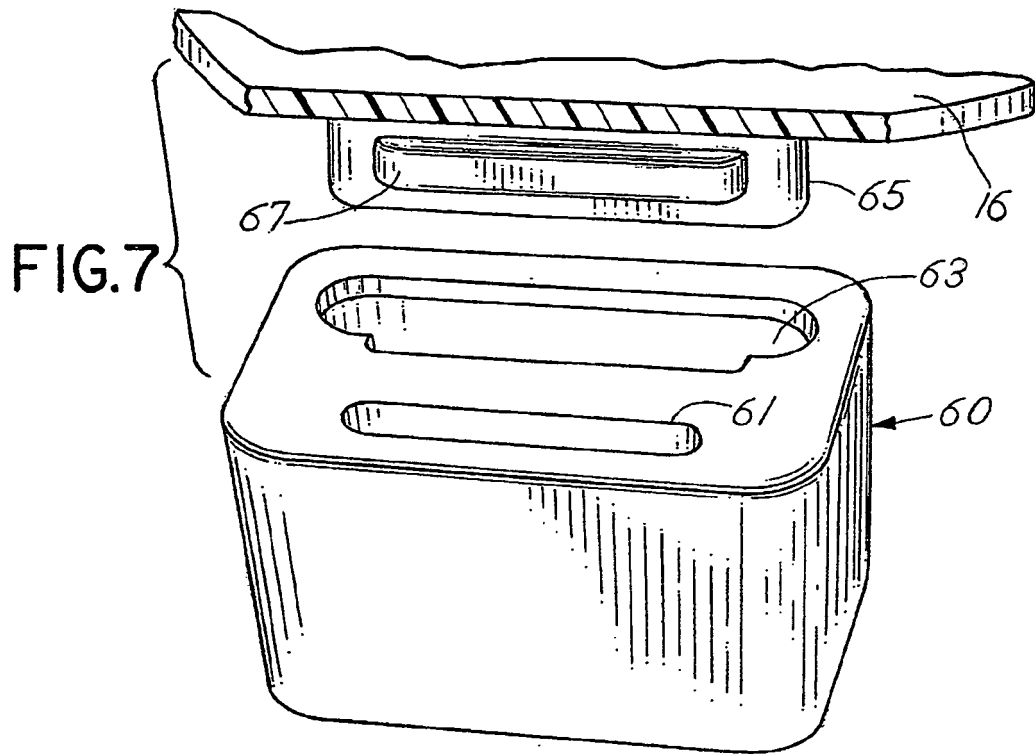

FIG.9

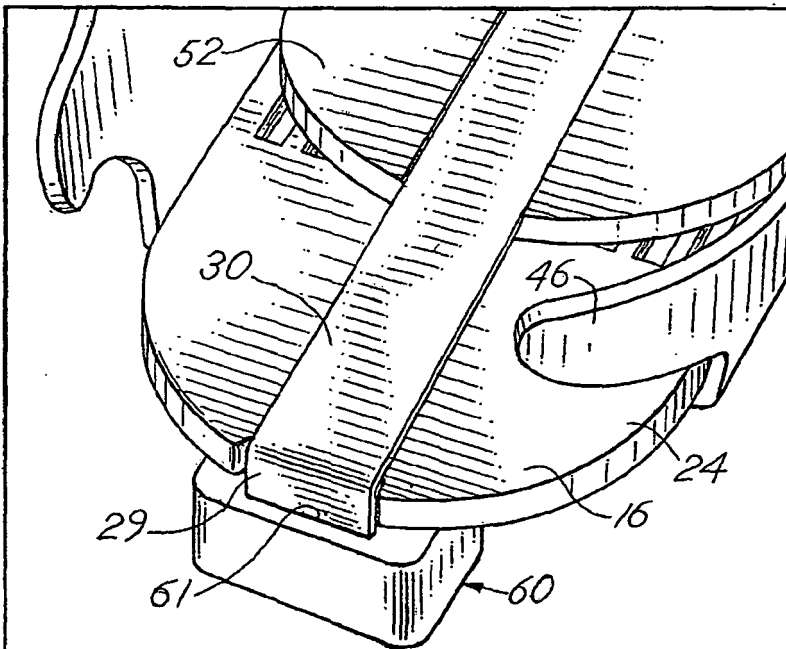
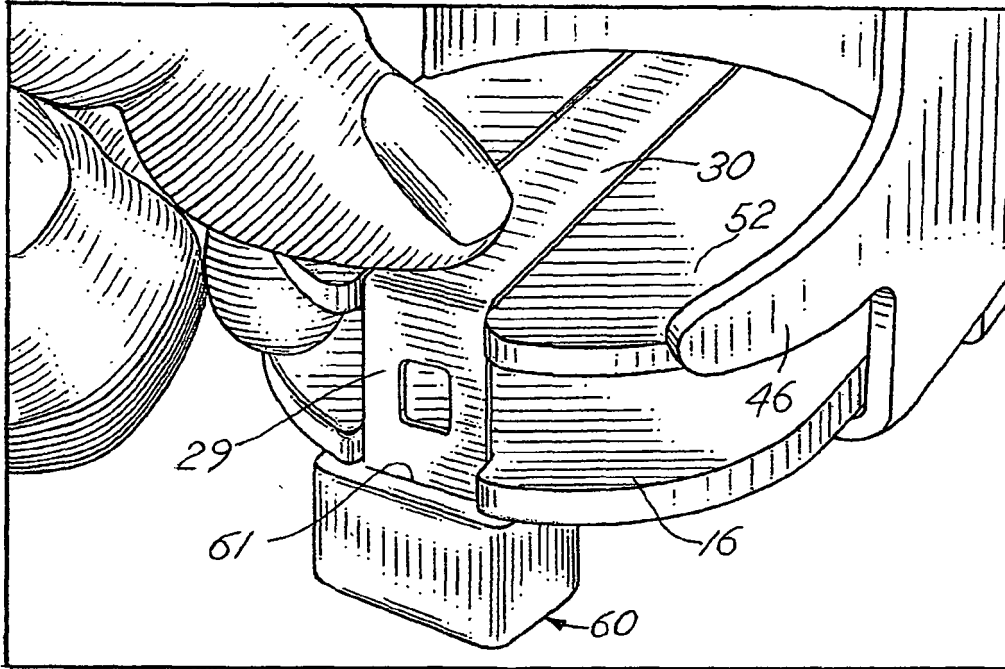

FIG.10

FIG. II

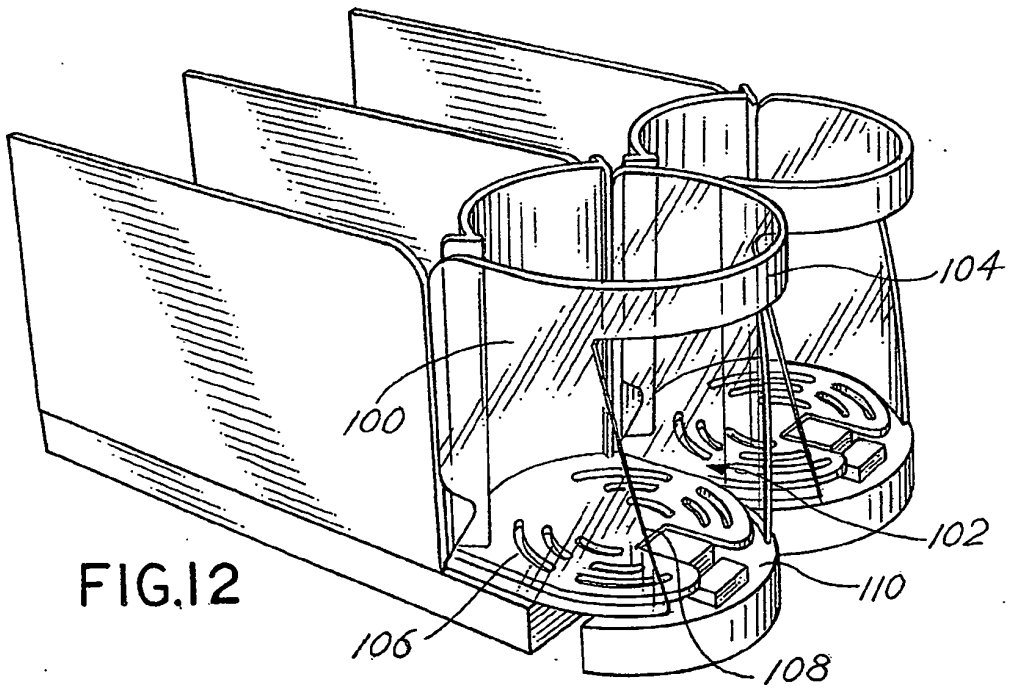
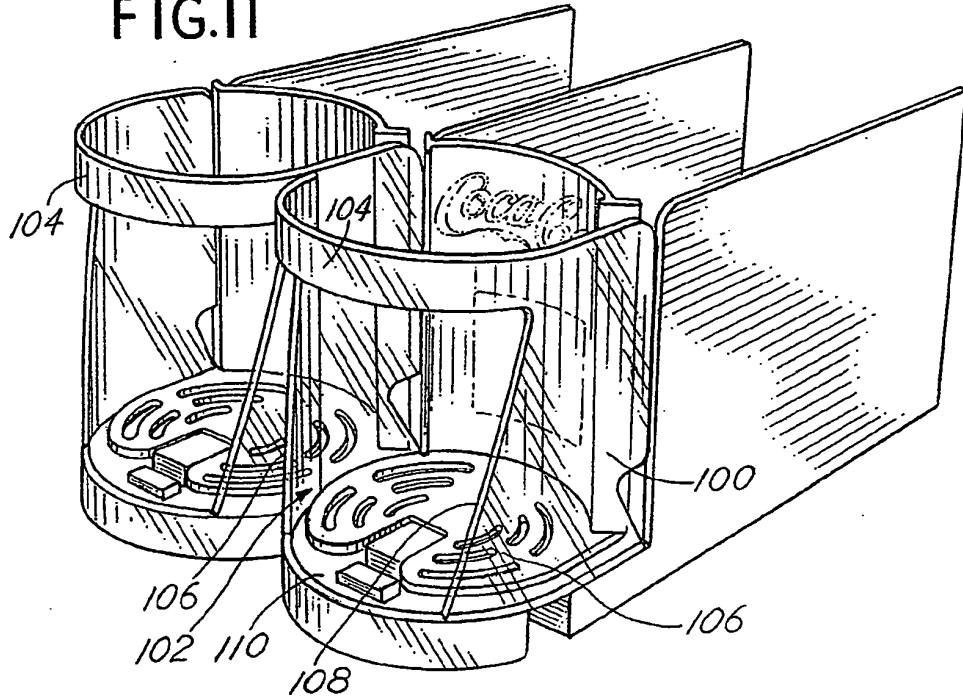

FIG. 12

FIG.13

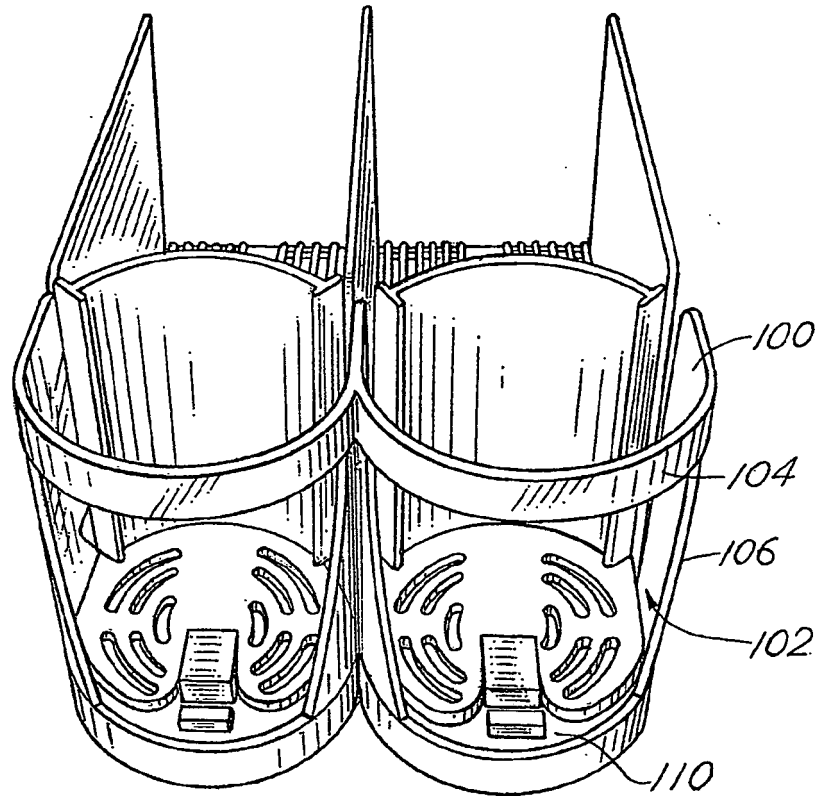

FIG.14

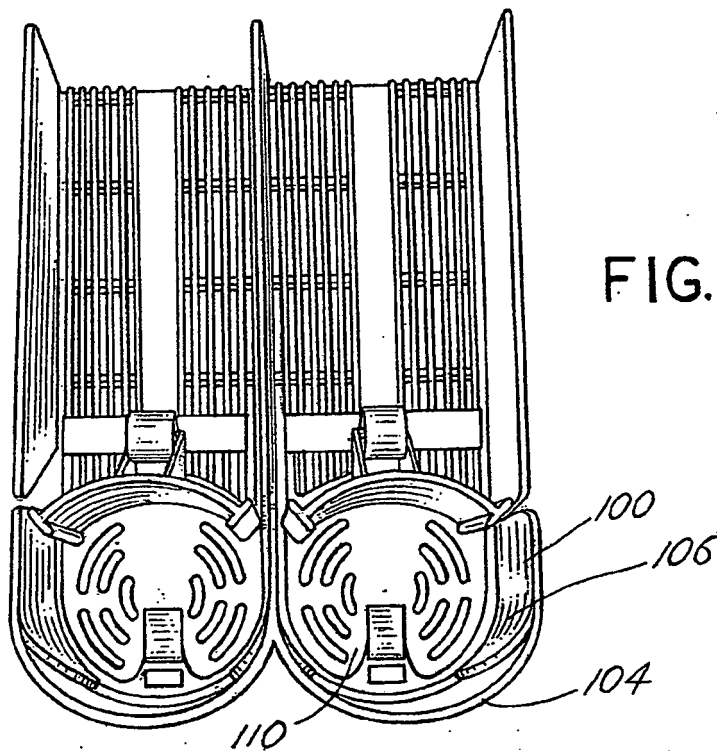

FIG.15

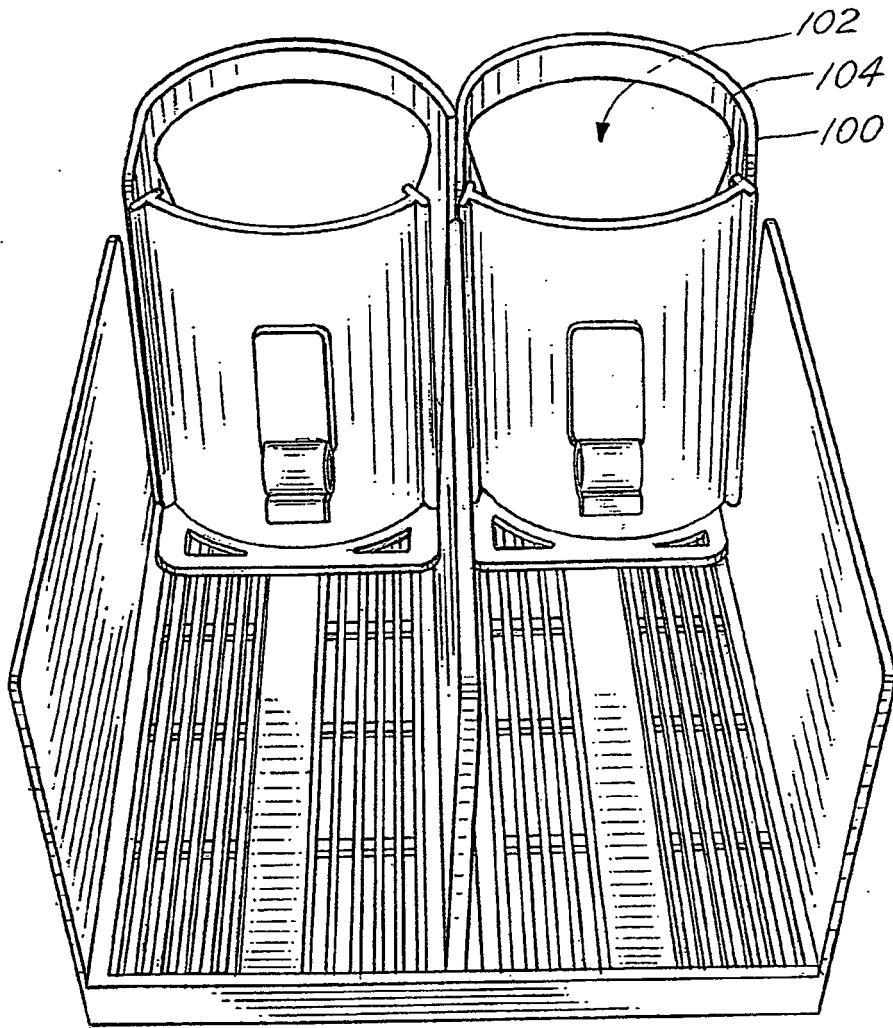

FIG.16

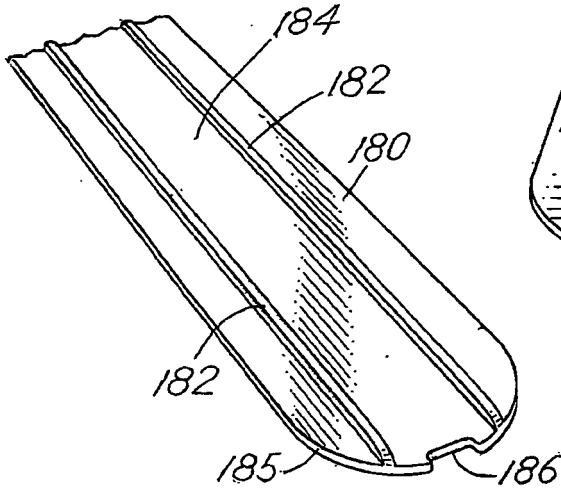

FIG.17

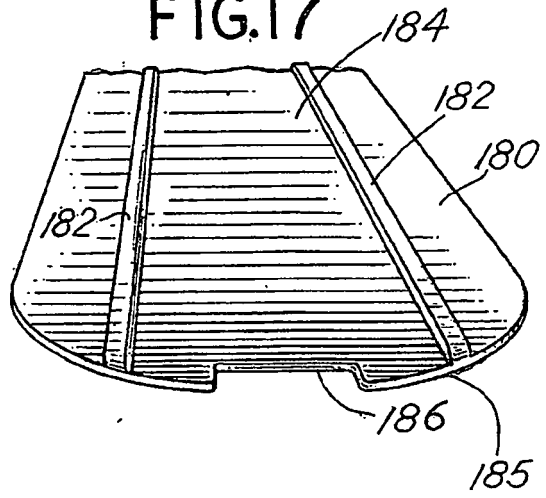

FIG.18

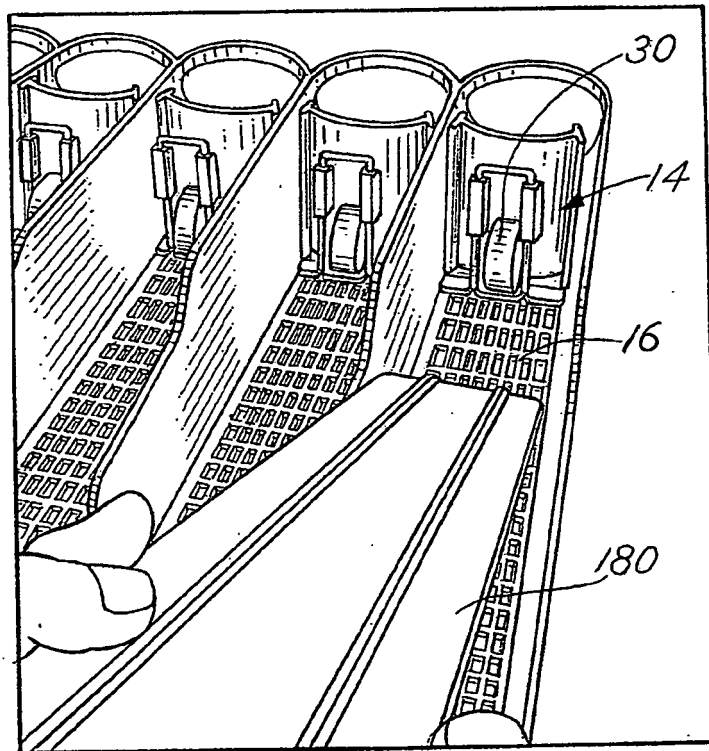

FIG.19

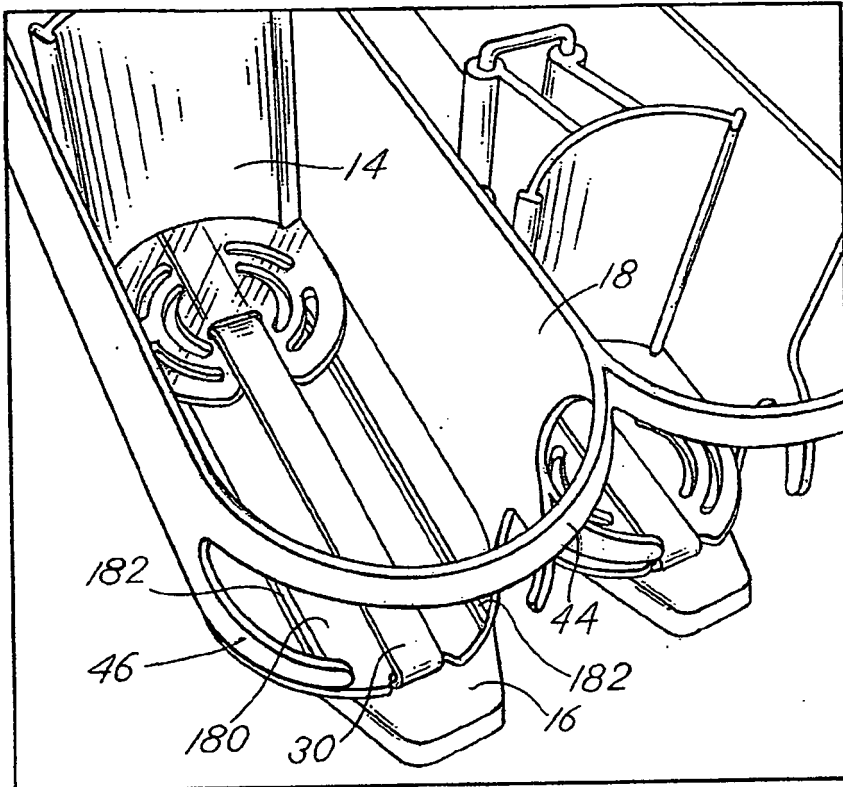

FIG.20

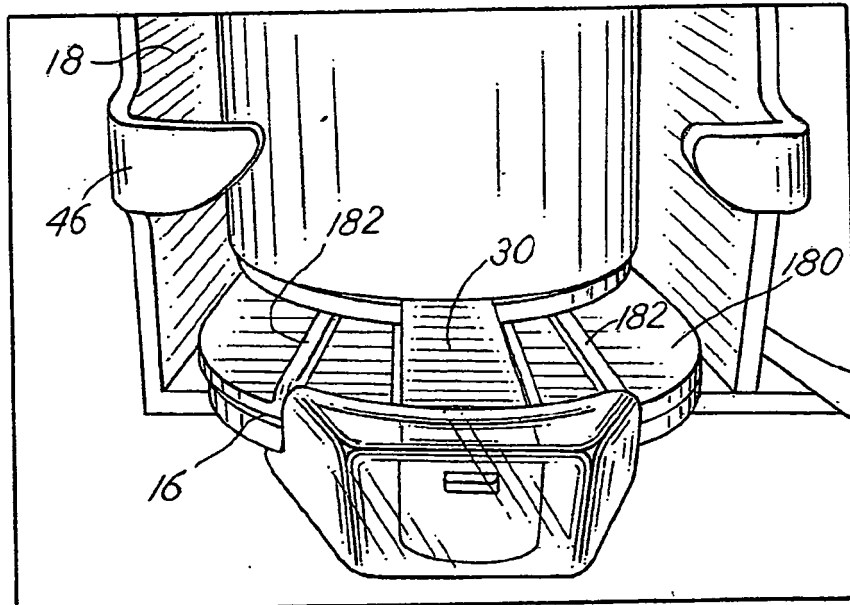

FIG.21

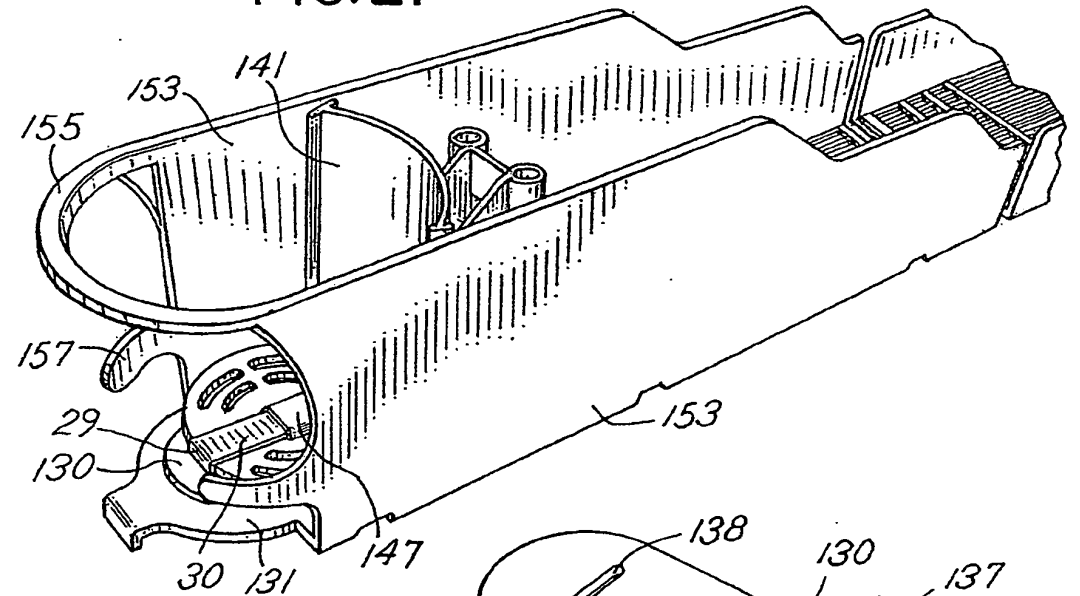

FIG.22

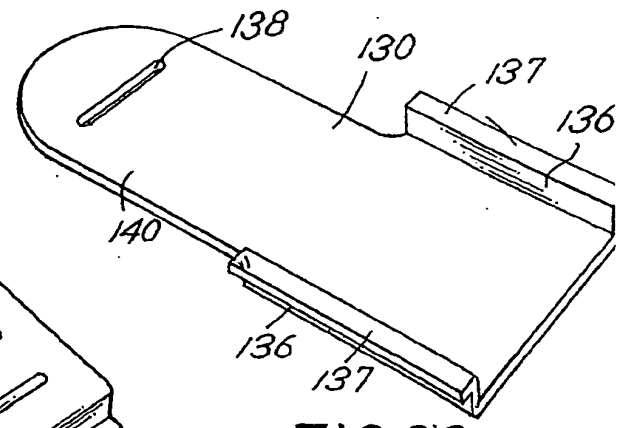

FIG.23

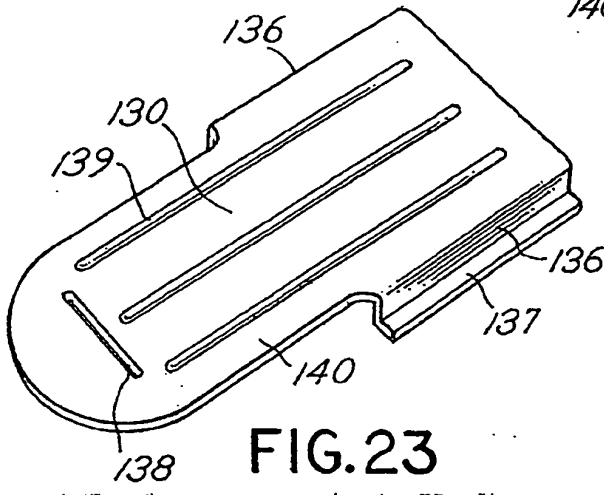

FIG.24

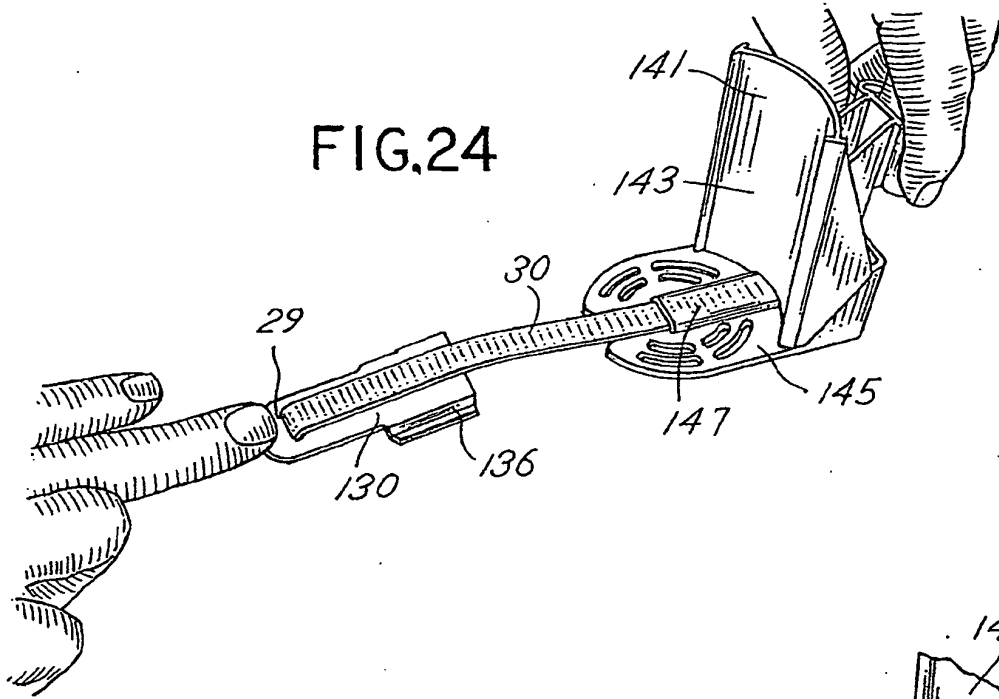

FIG.25

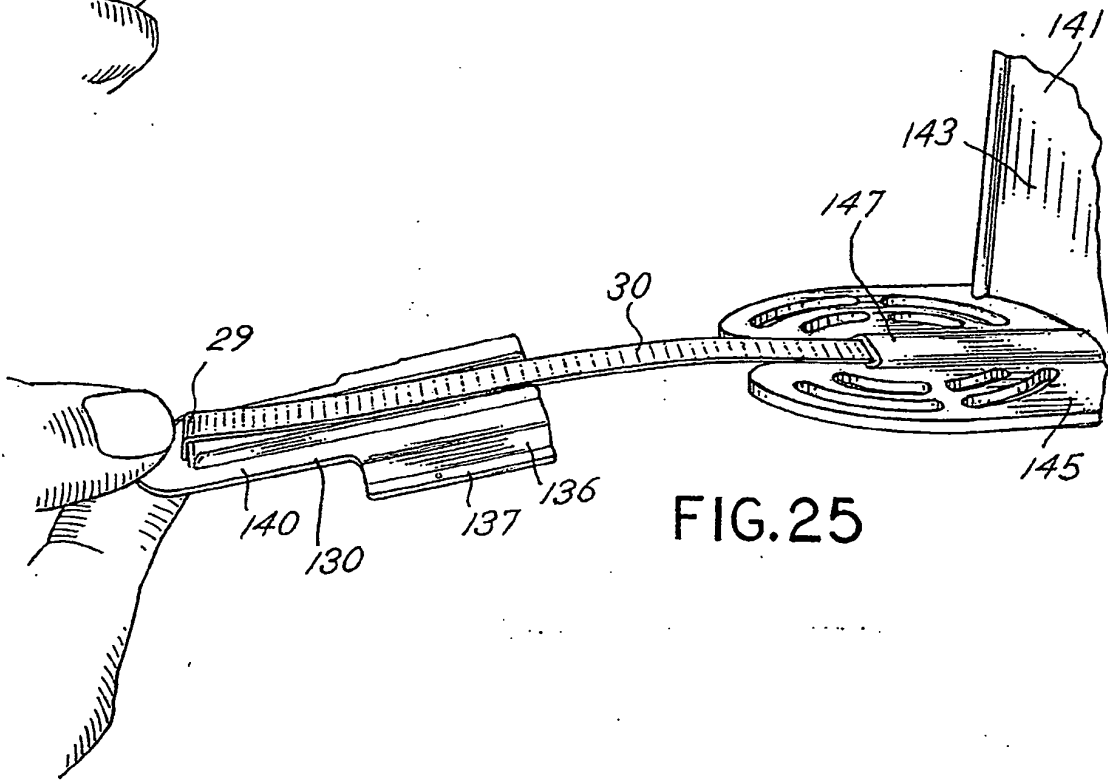

FIG.26

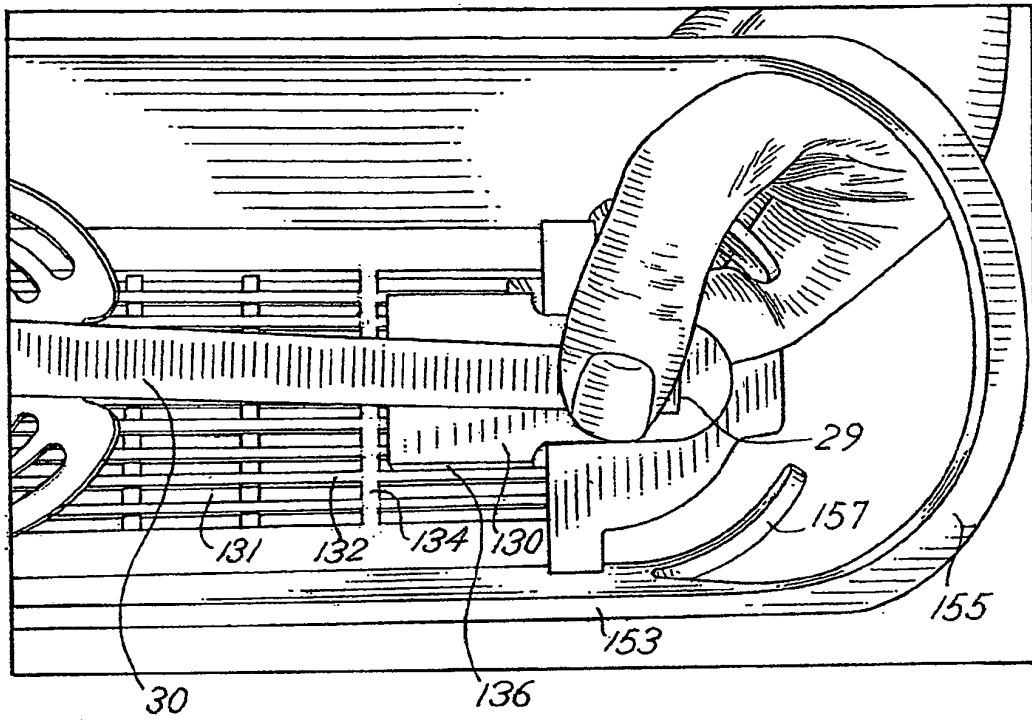
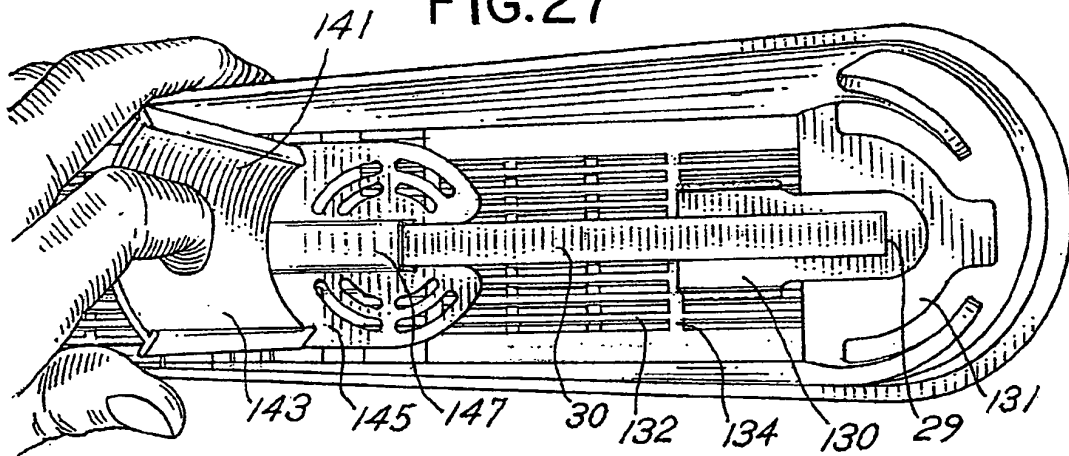

FIG.27



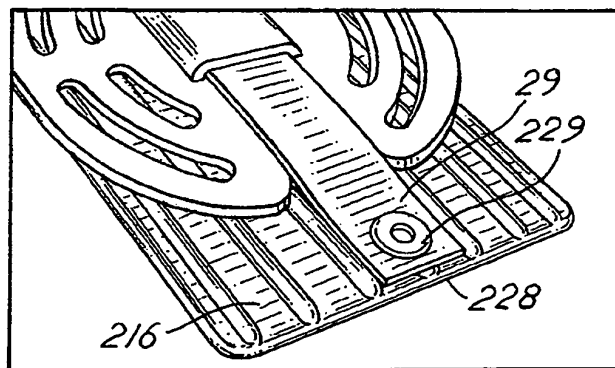
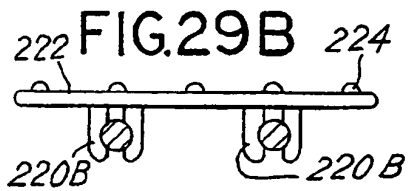
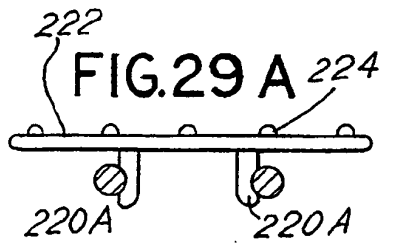
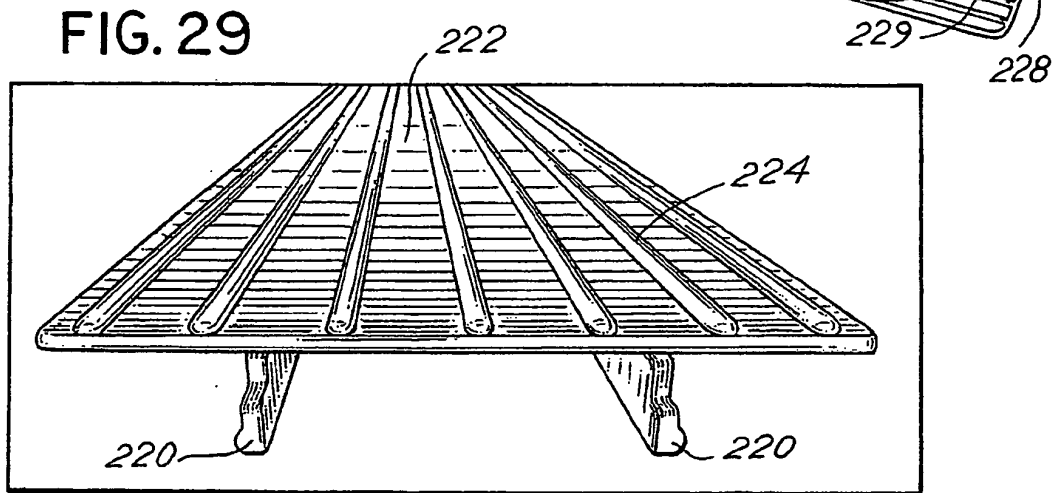
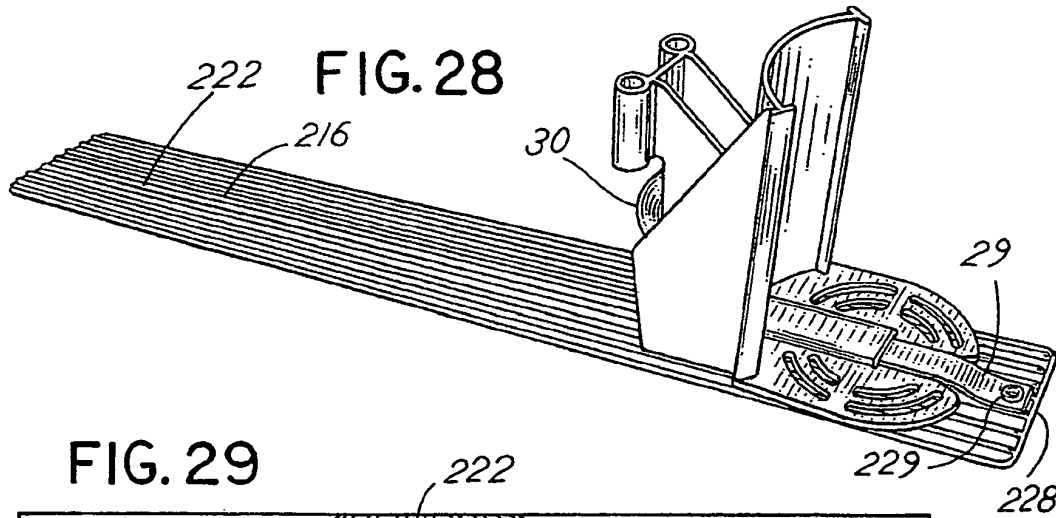

FIG.31

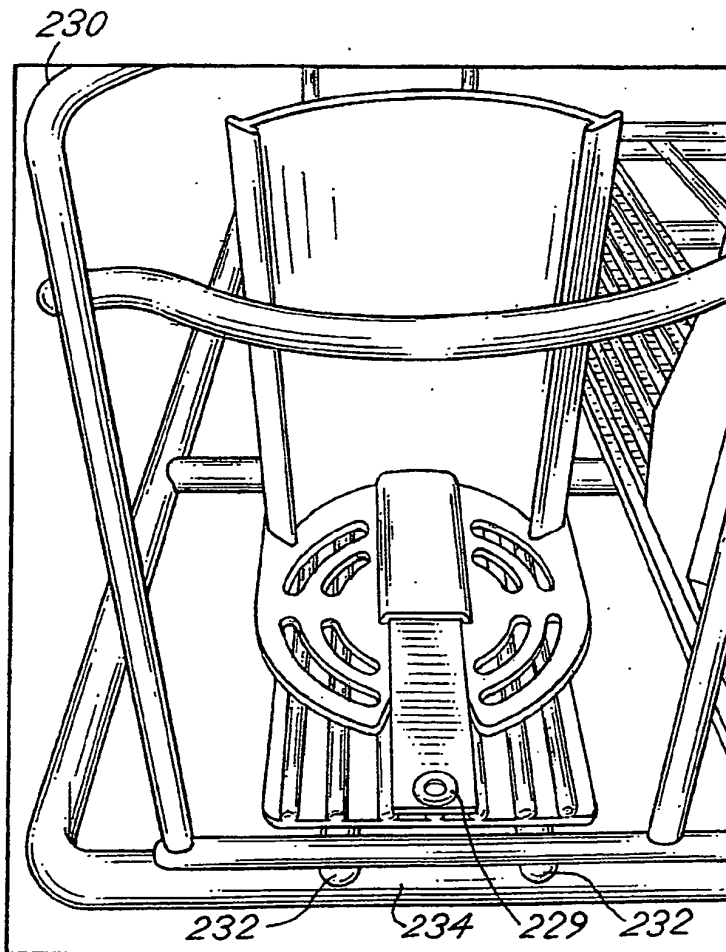
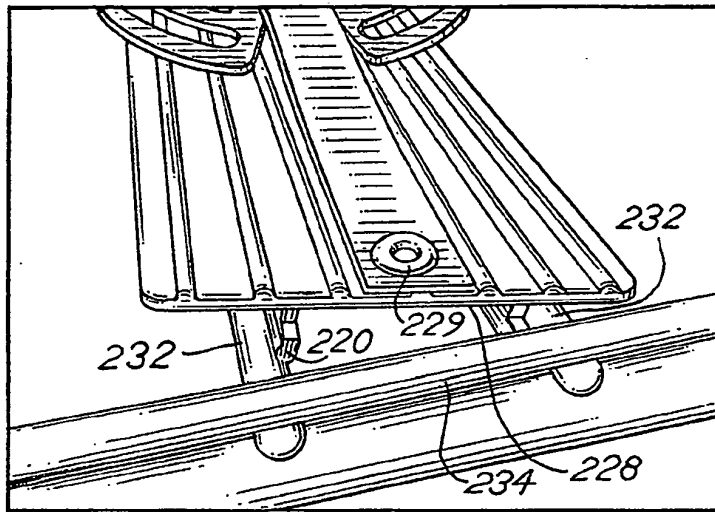

FIG.32

FIG. 33

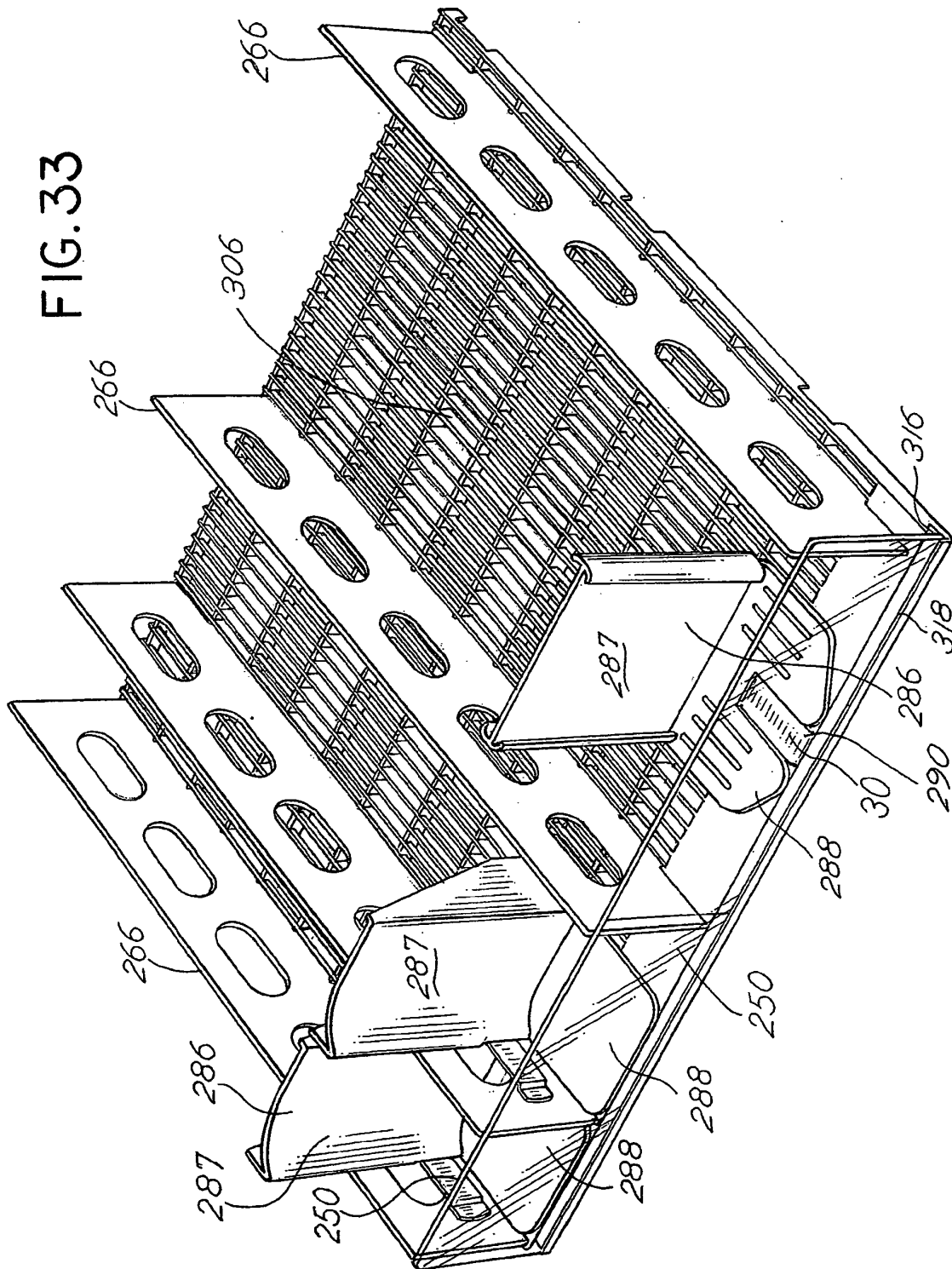
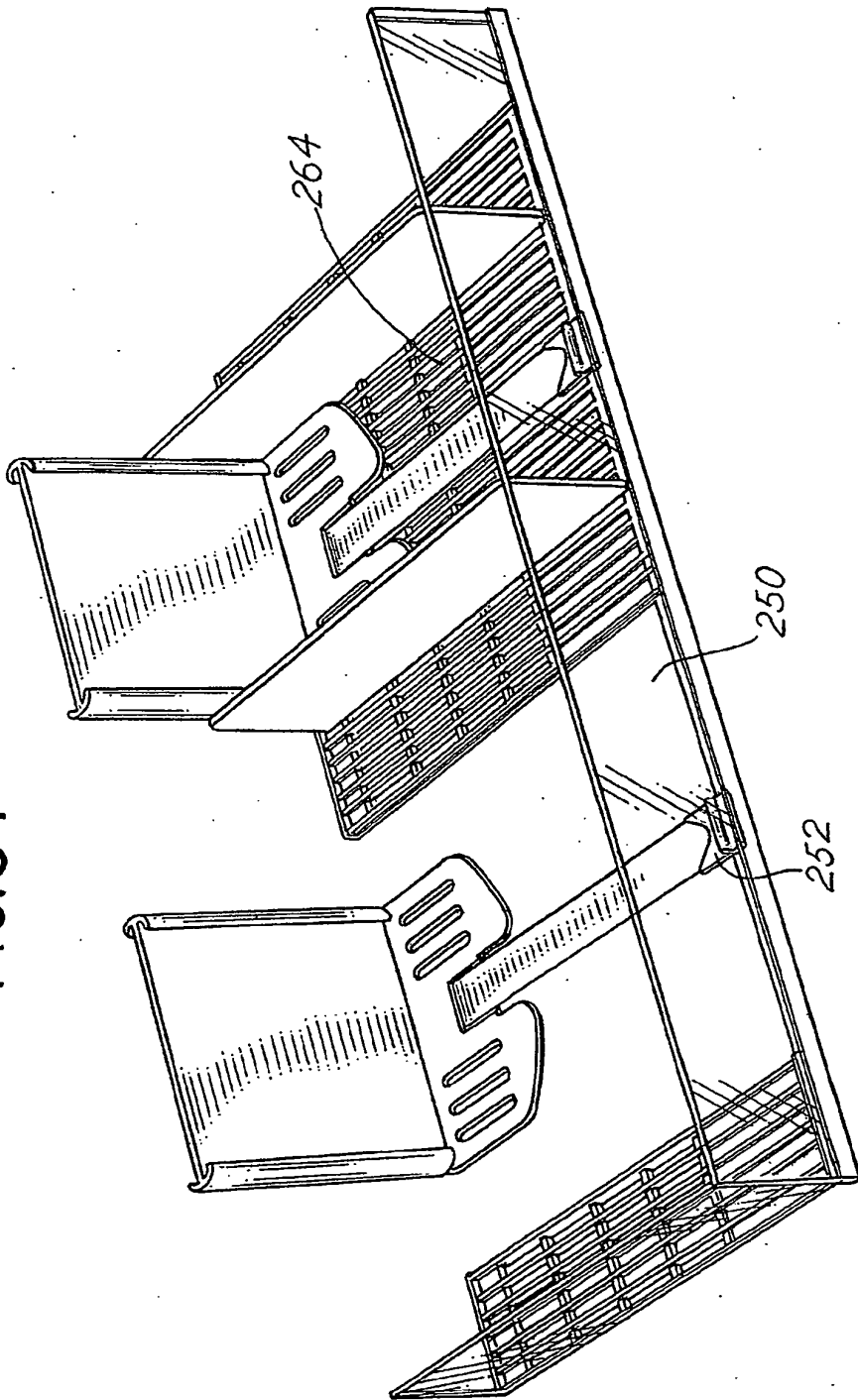

FIG. 34



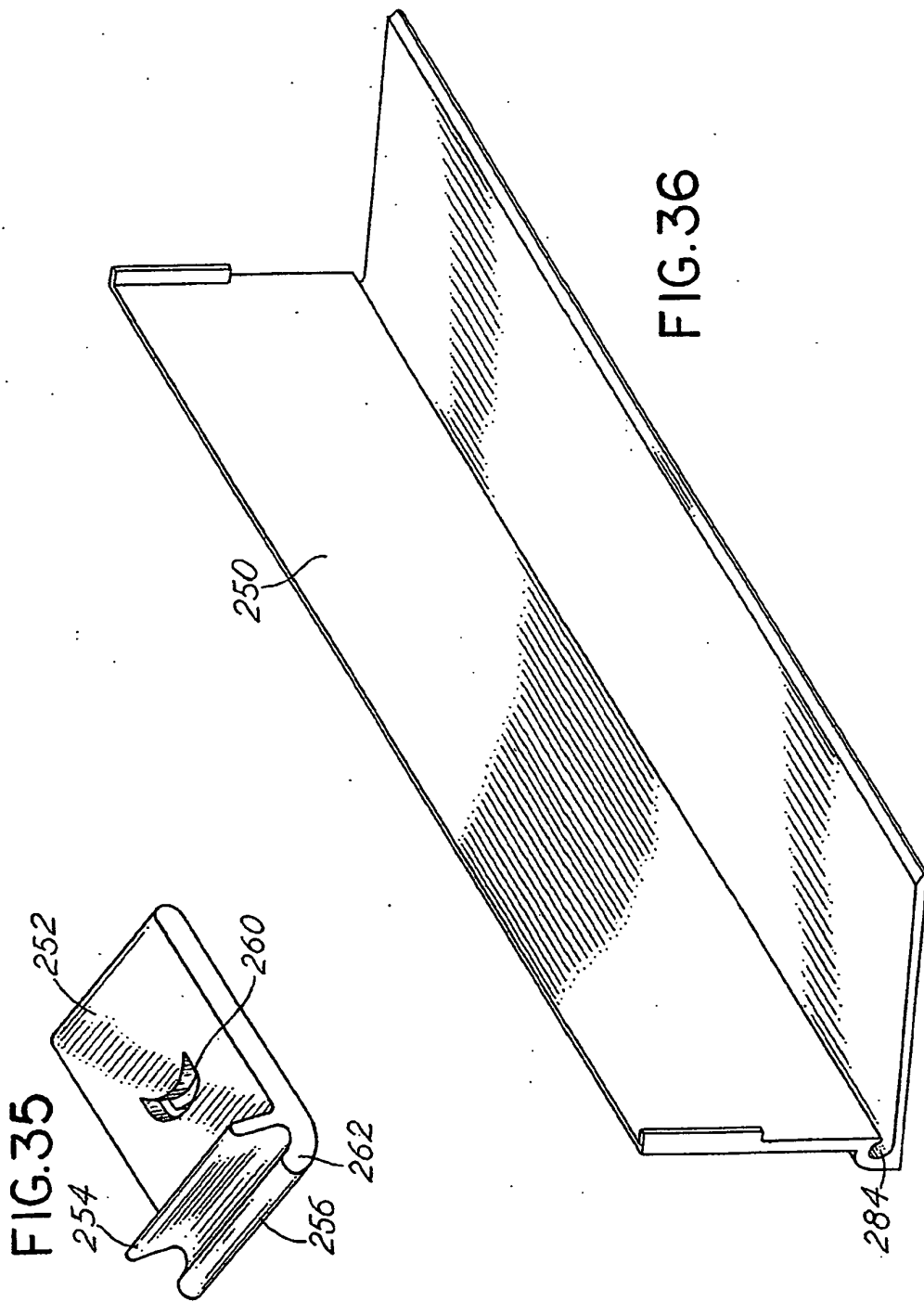

FIG. 37

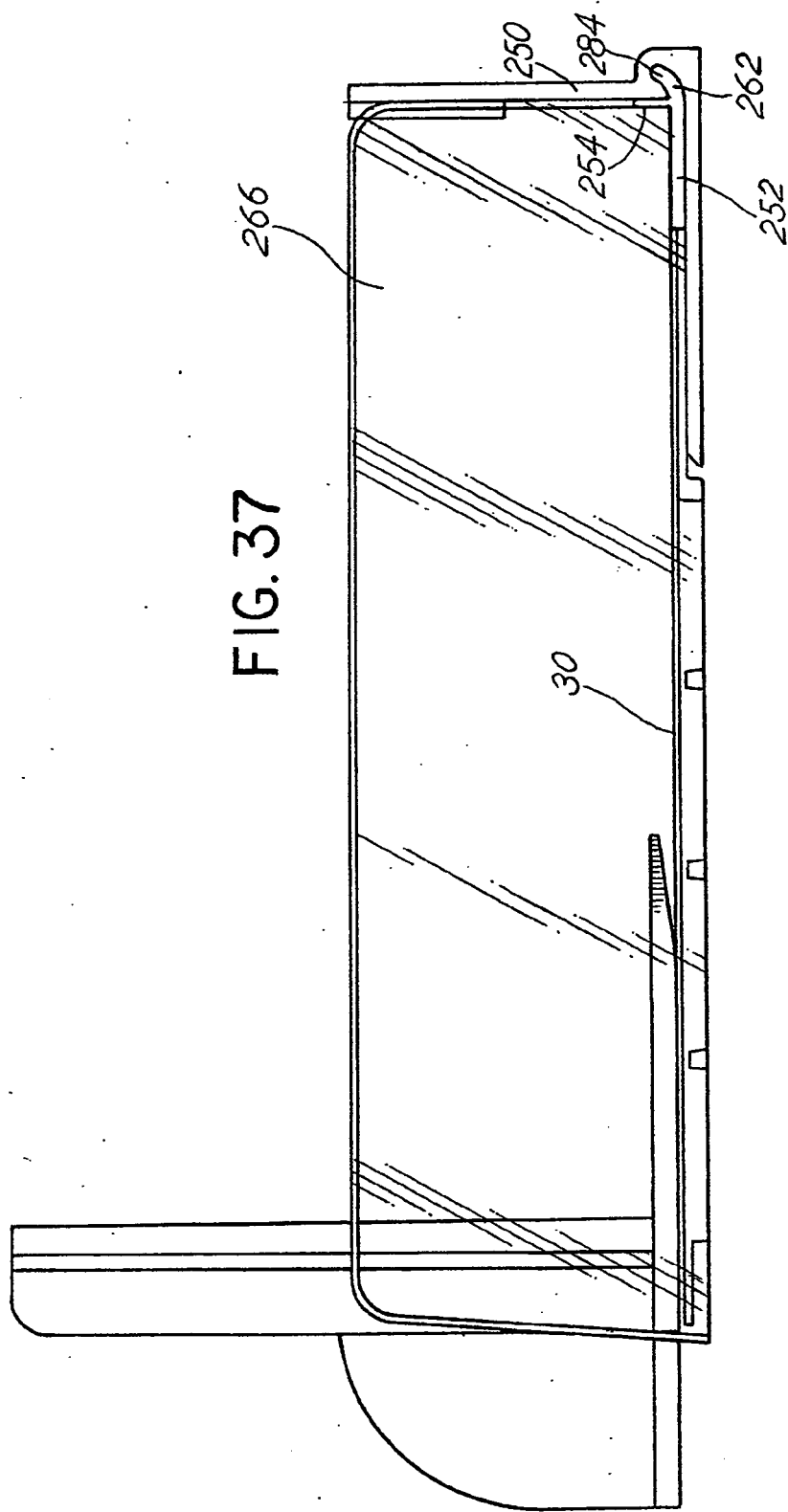

FIG. 38

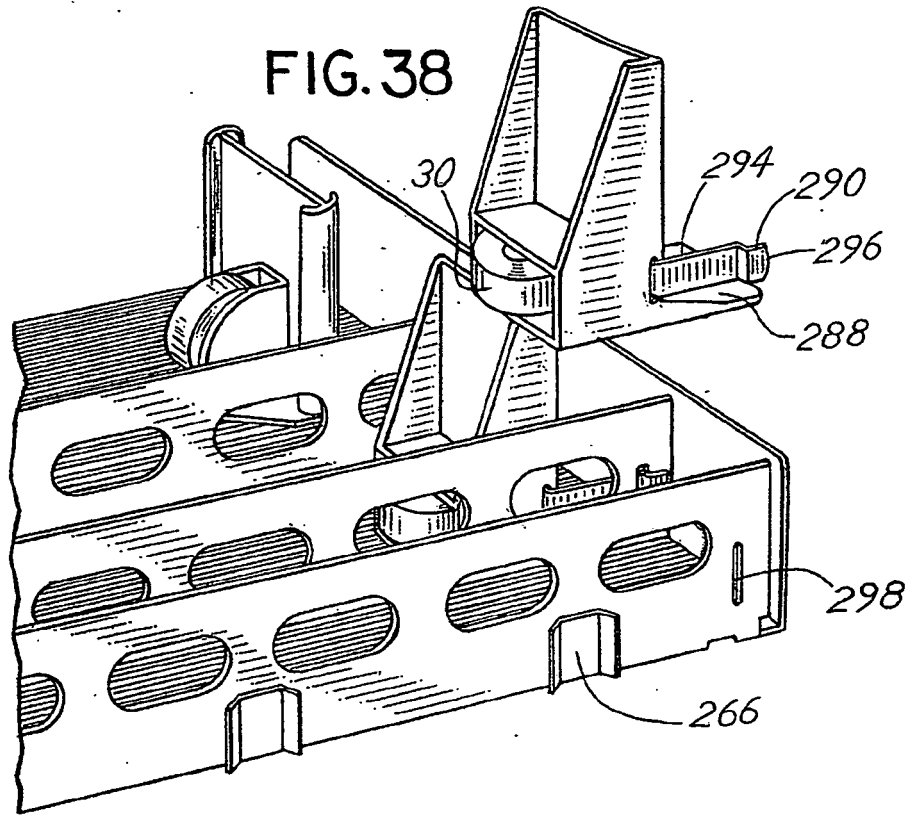
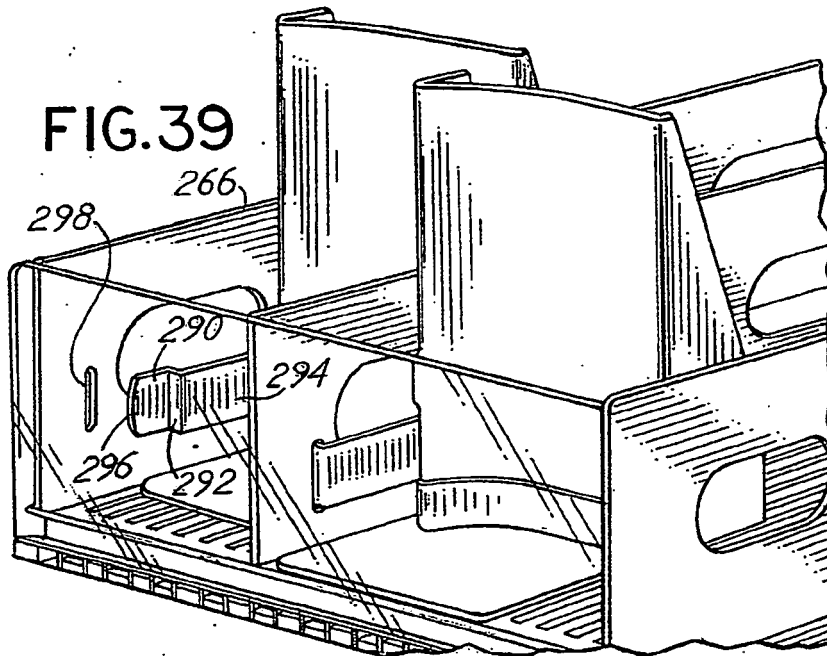

FIG. 39



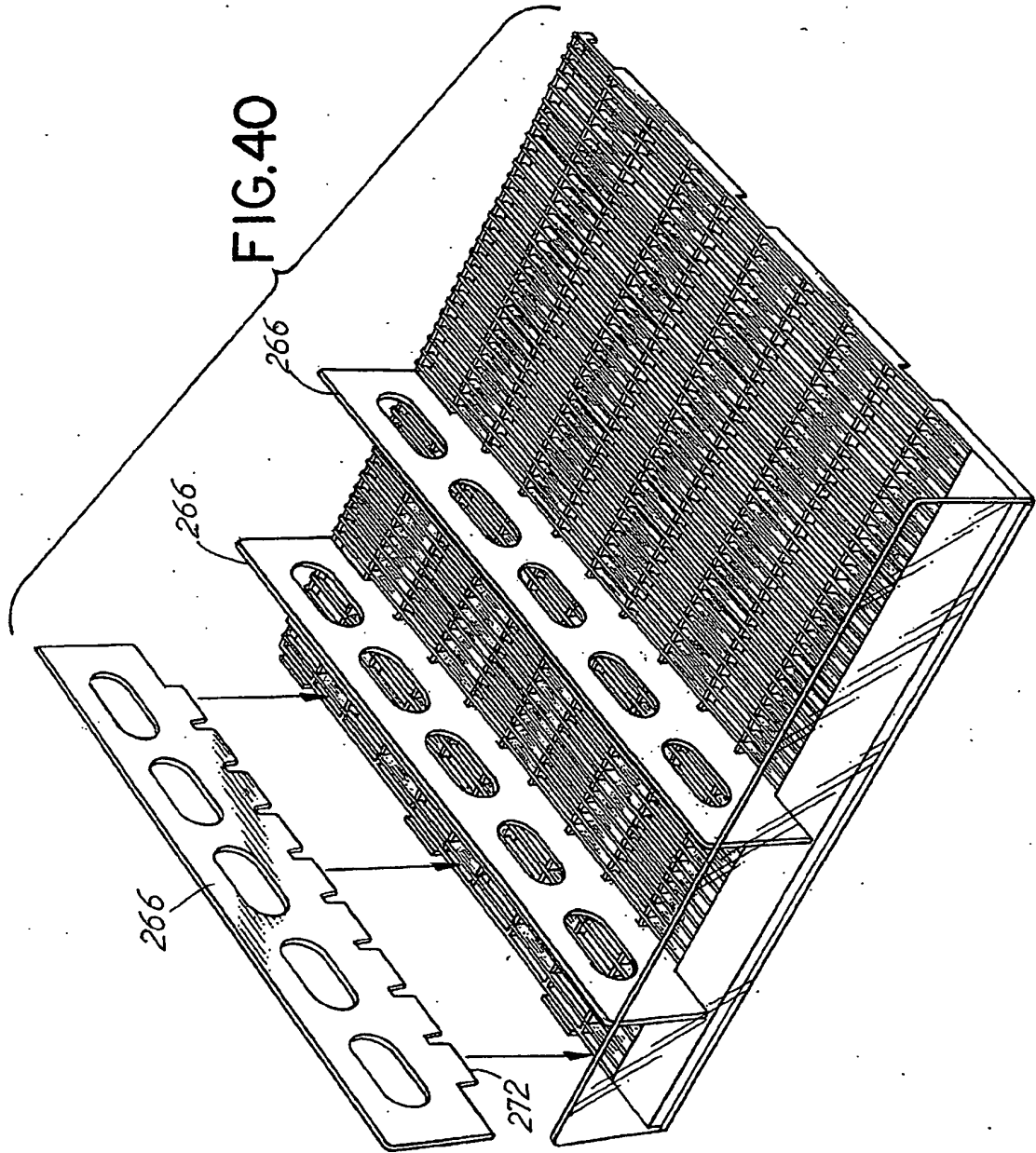

FIG.4IA

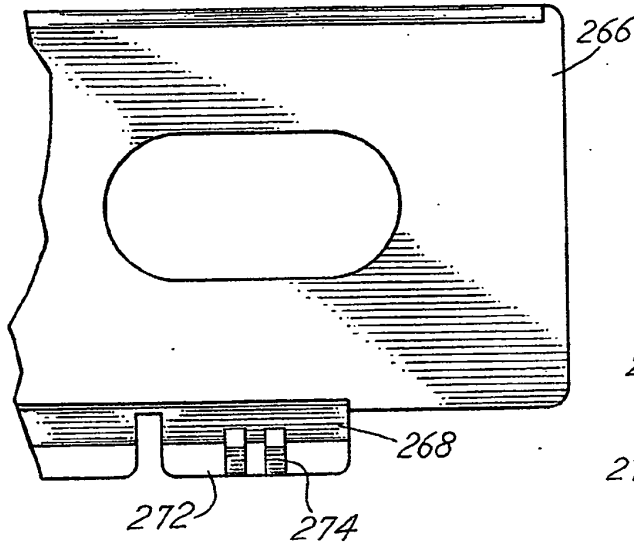

FIG.4ID

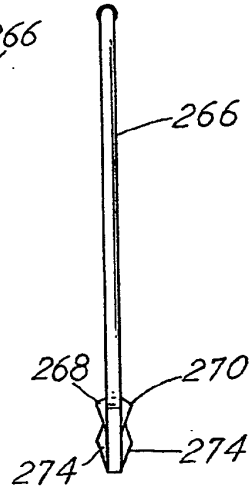
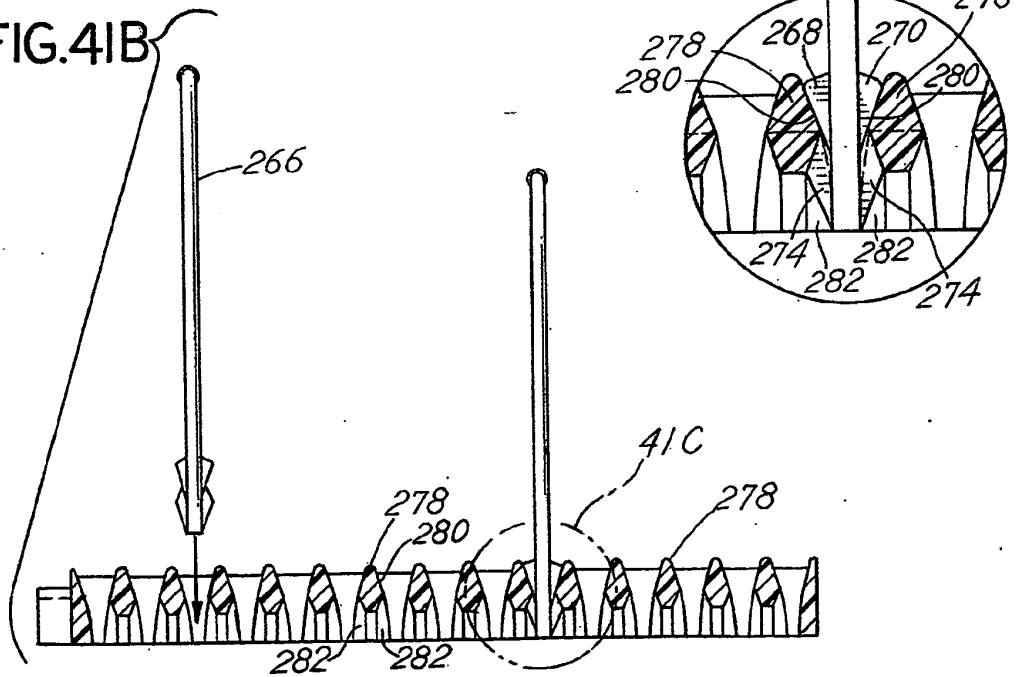
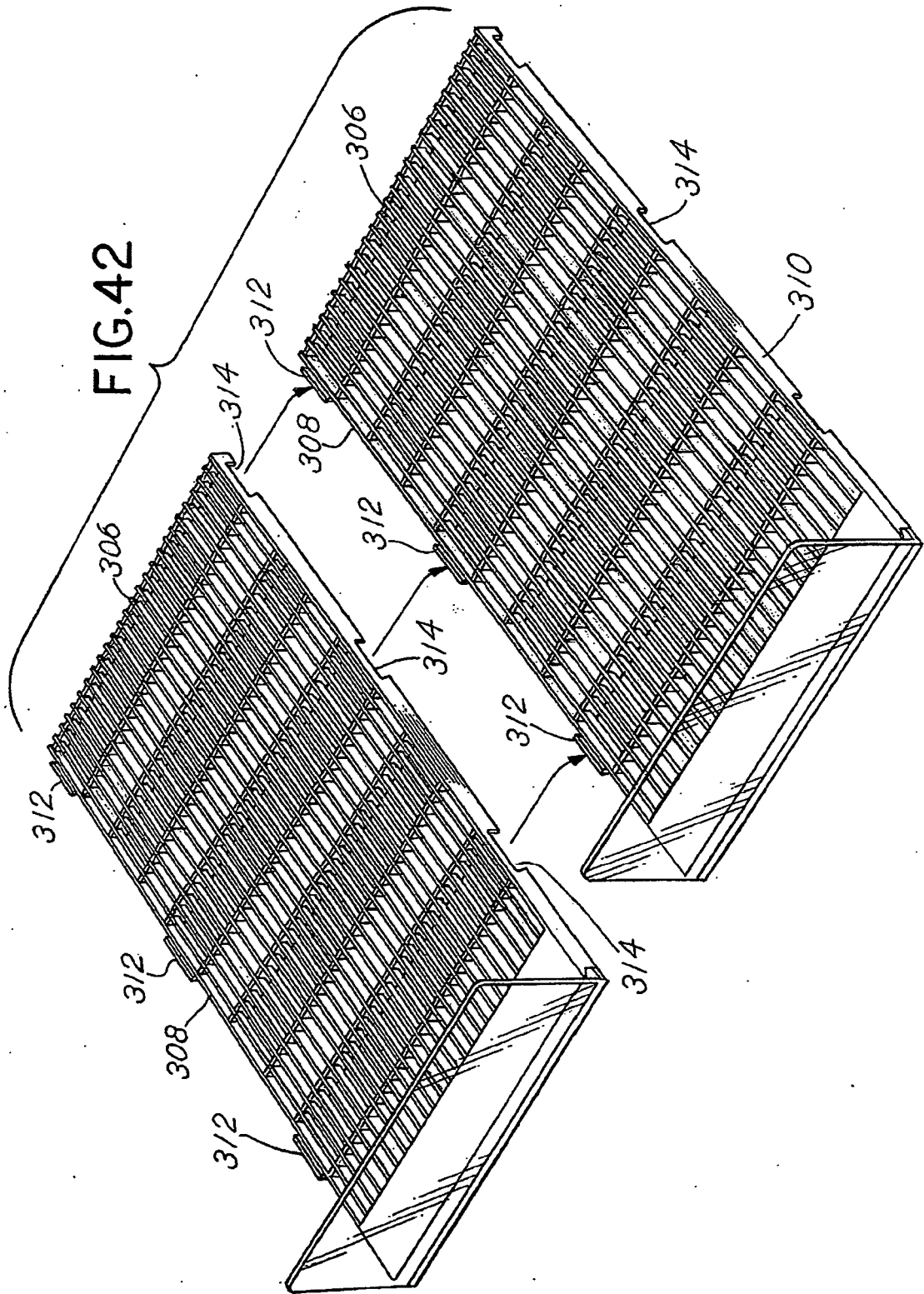
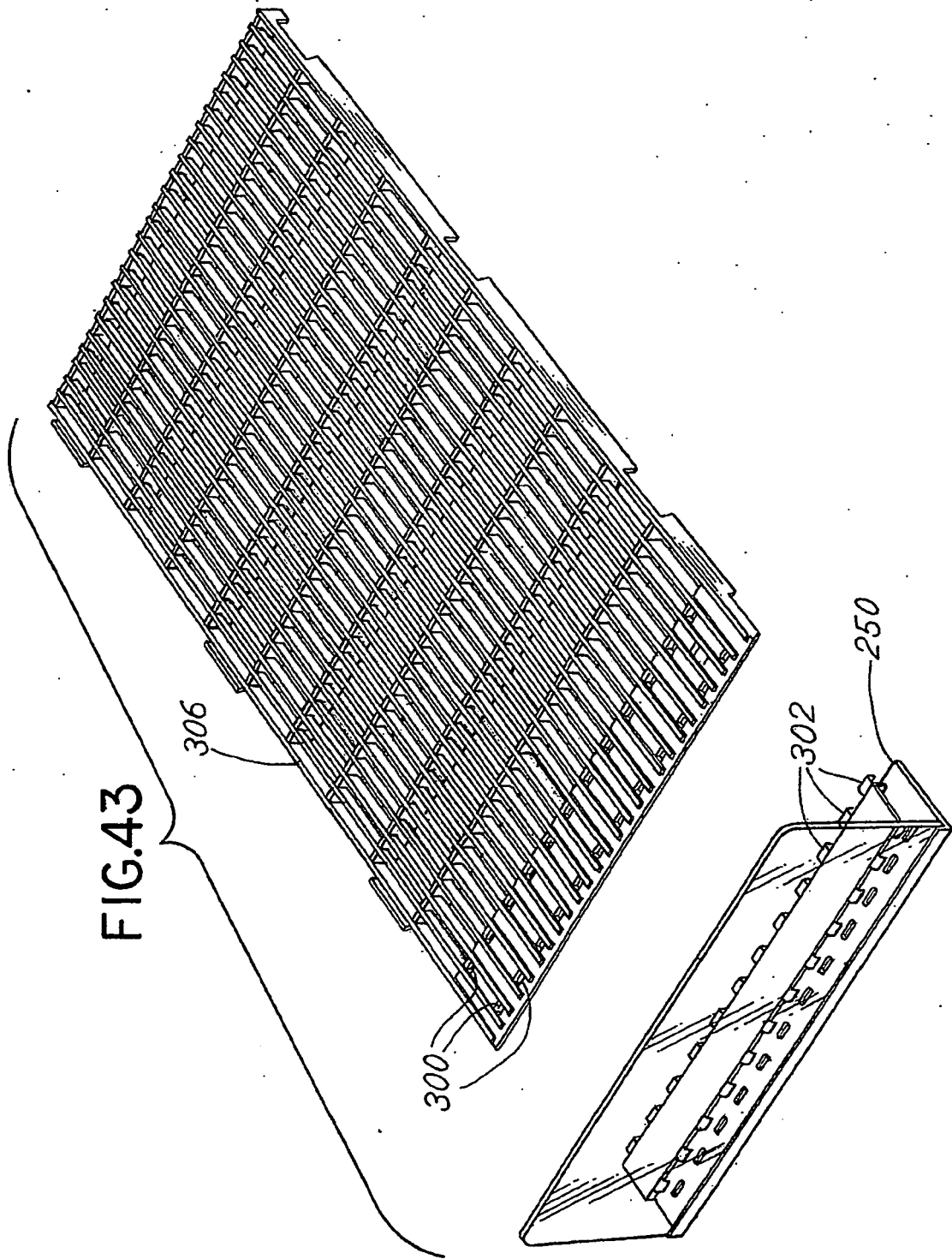

FIG.4IC

FIG.4IB







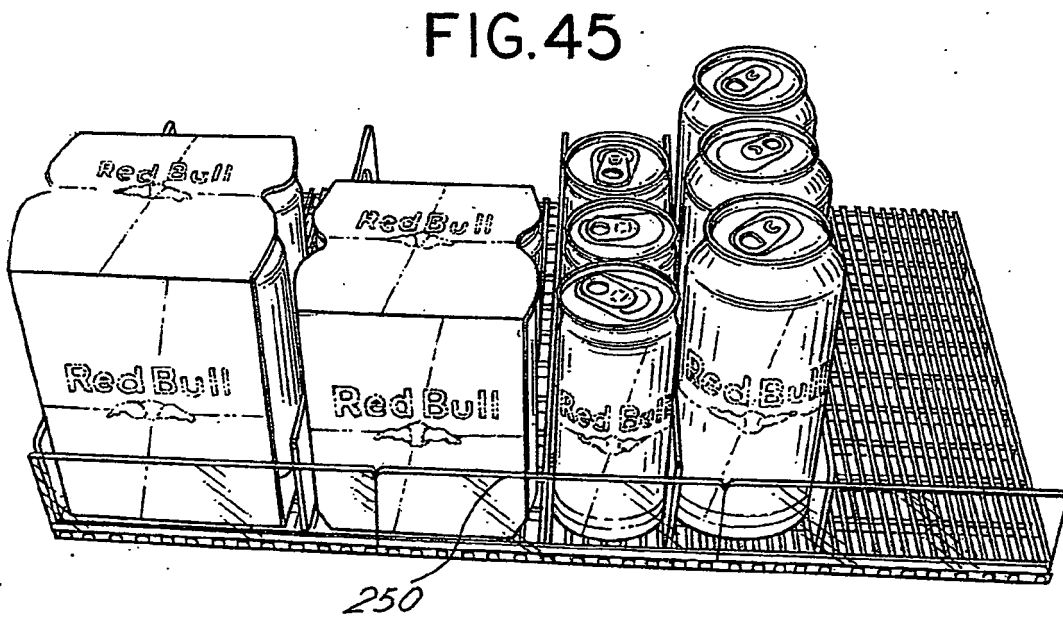
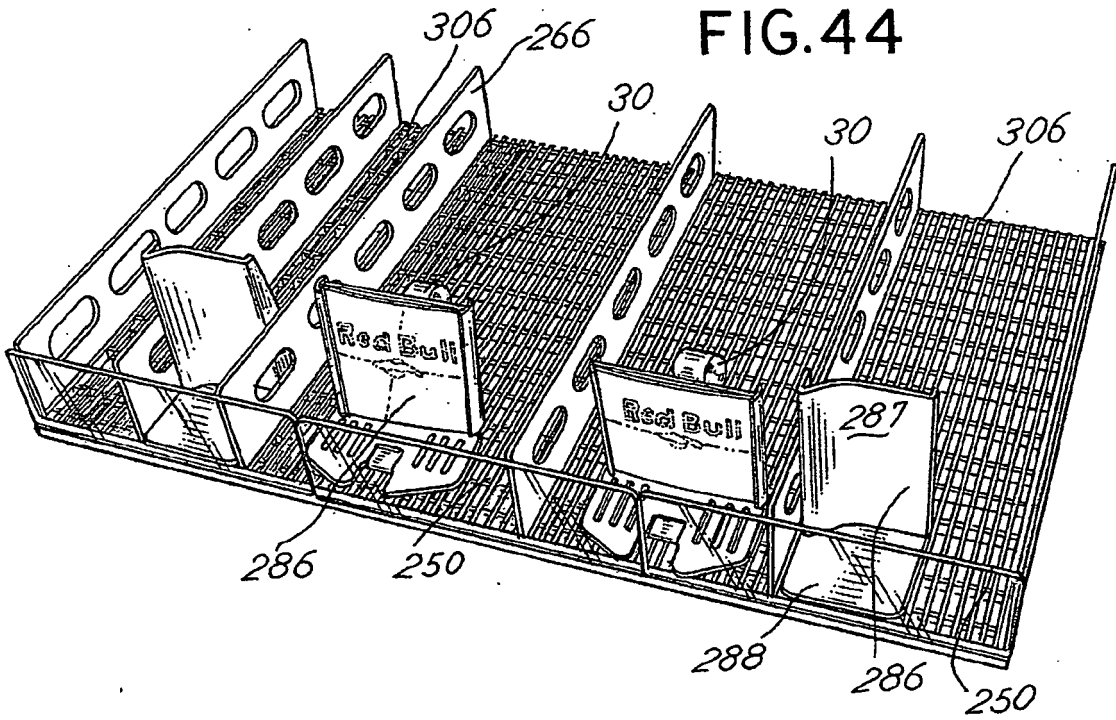

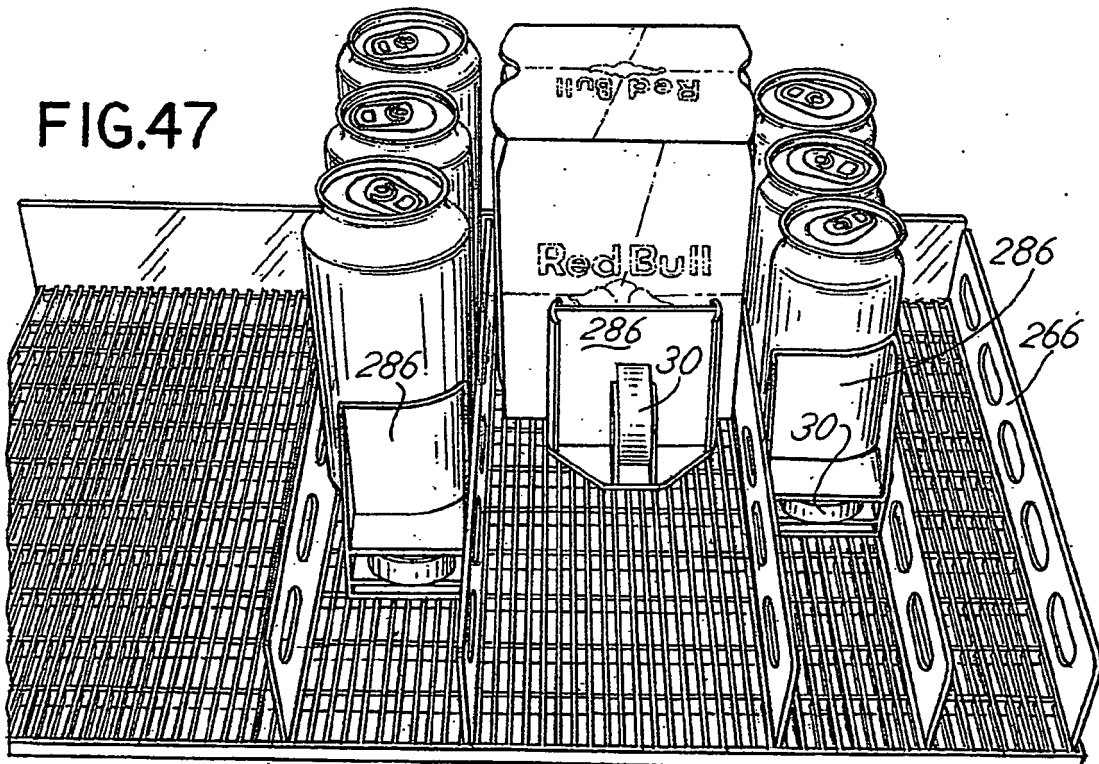
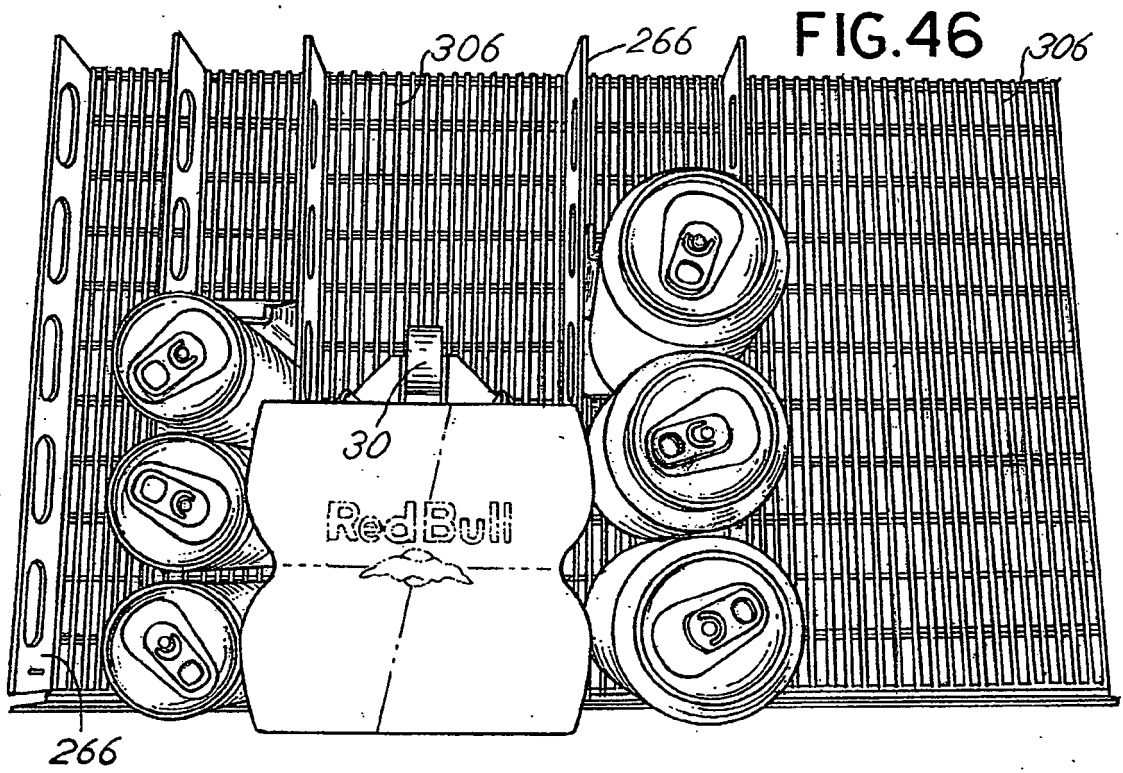

FIG.48

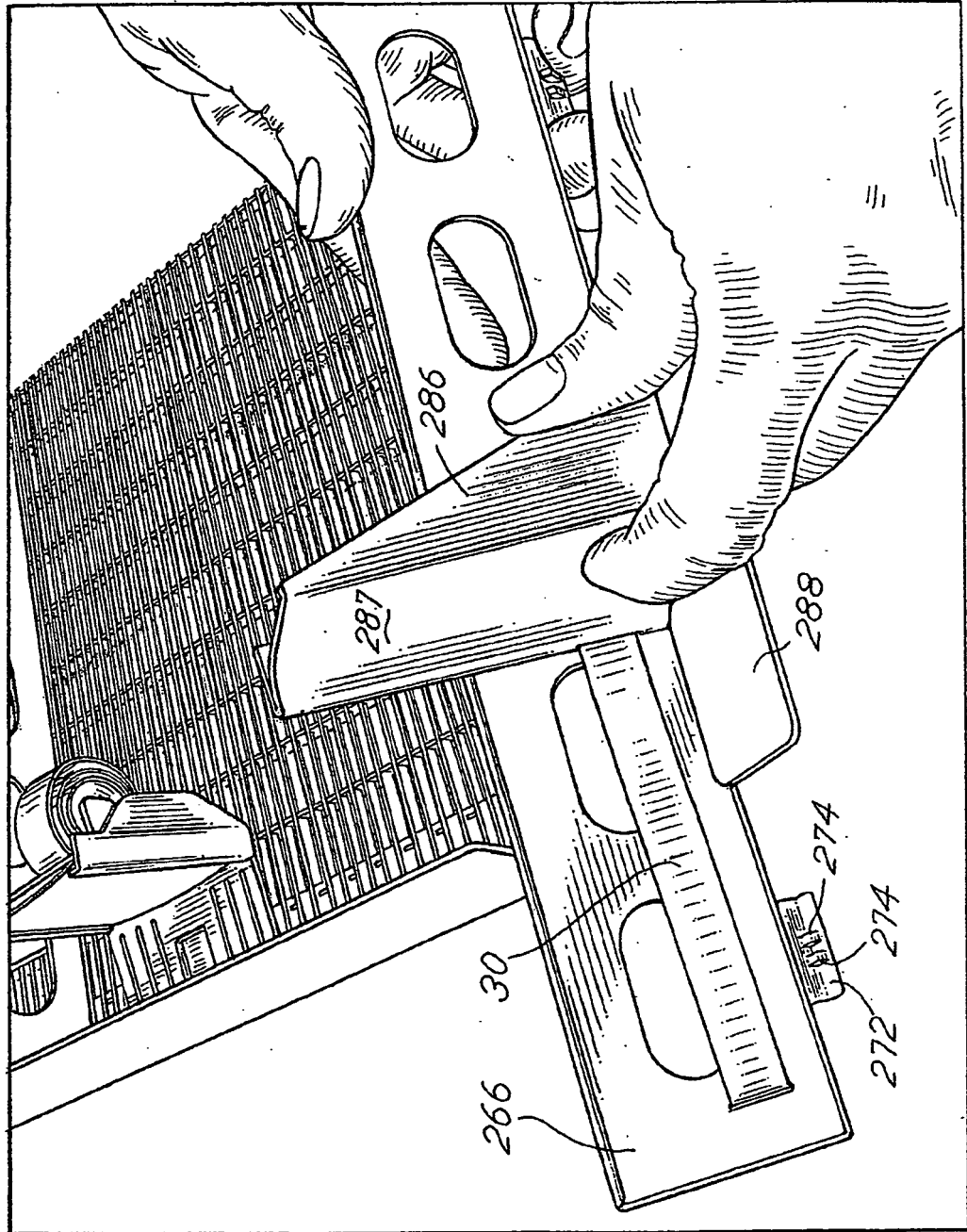
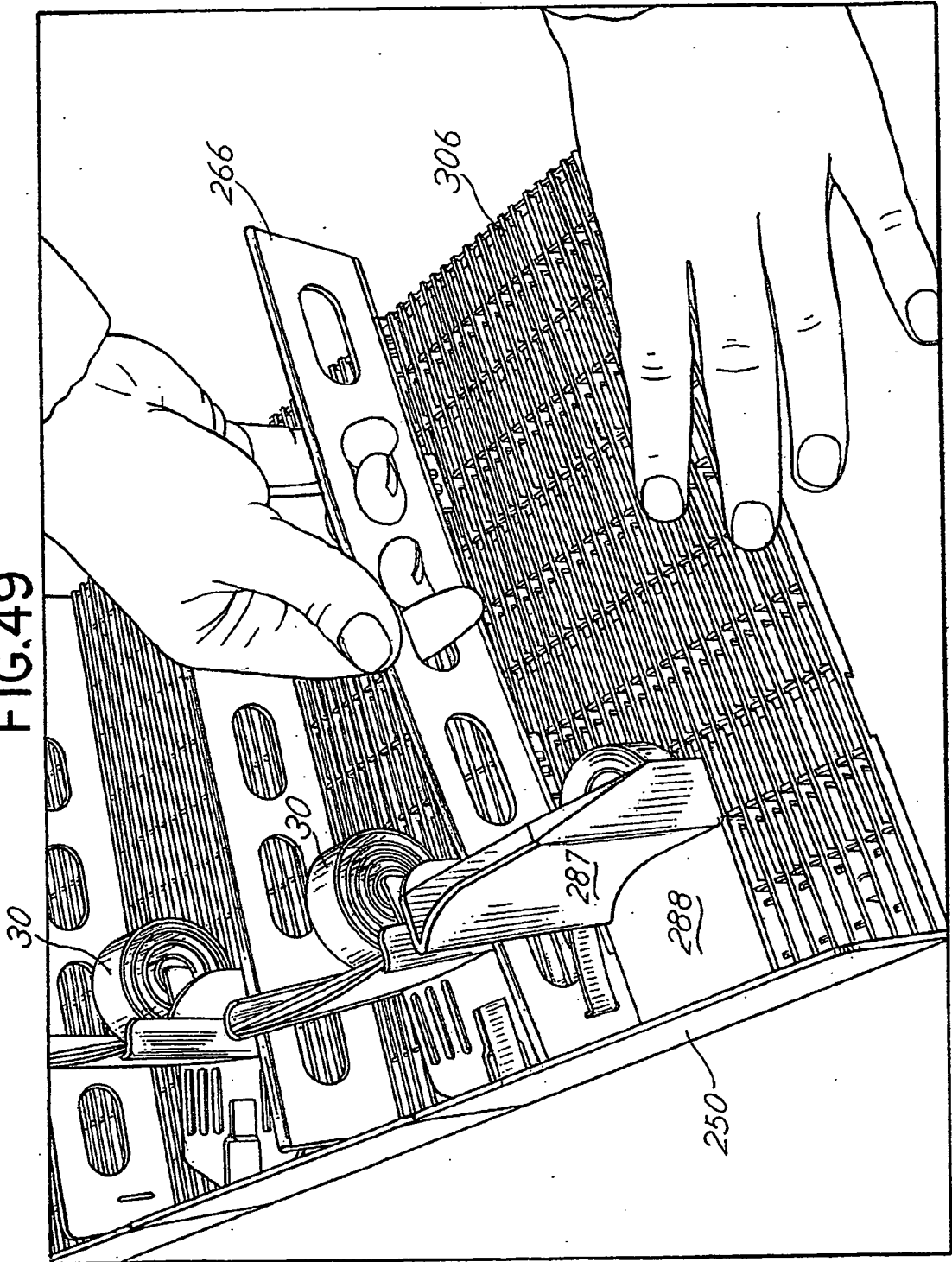
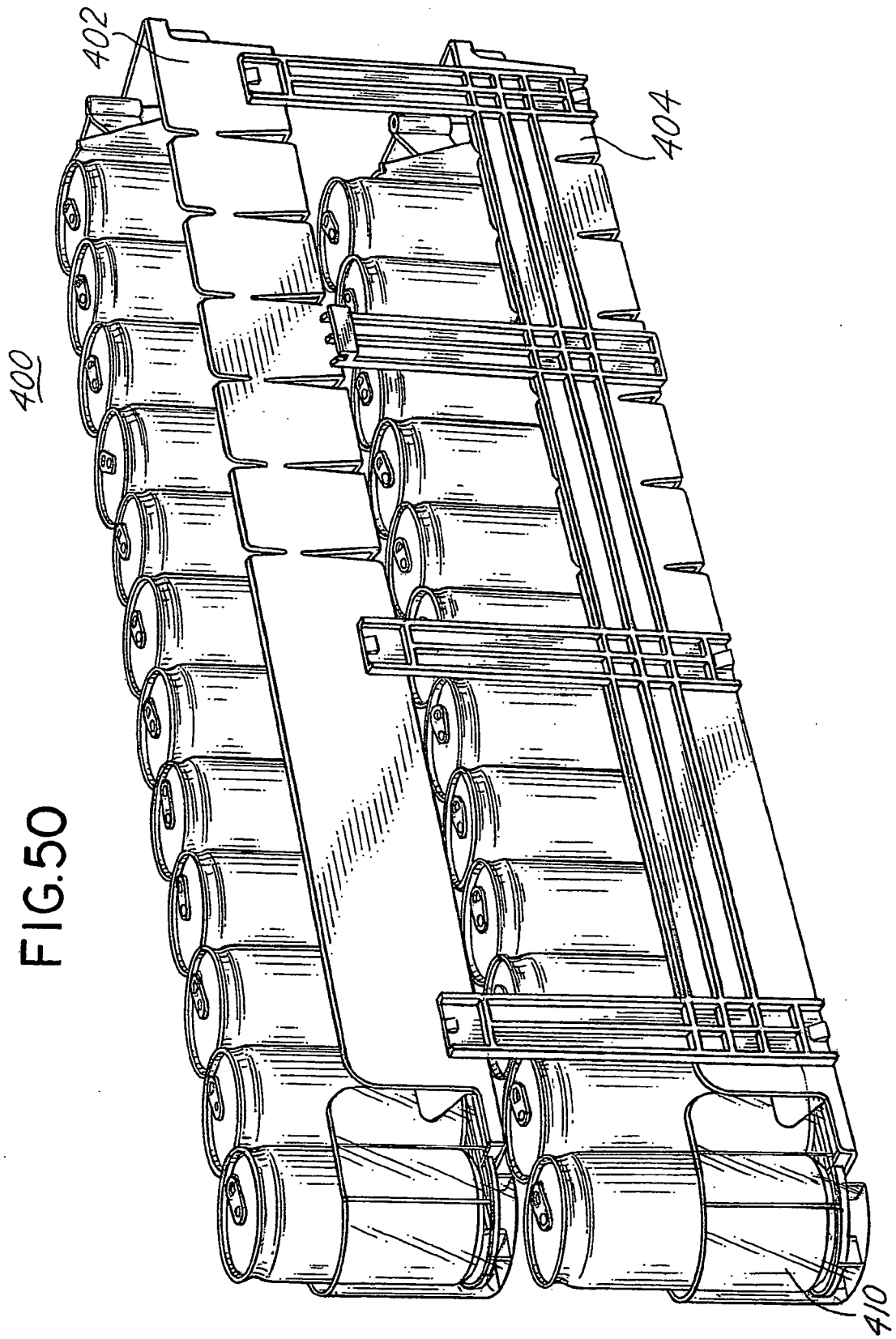

FIG.49





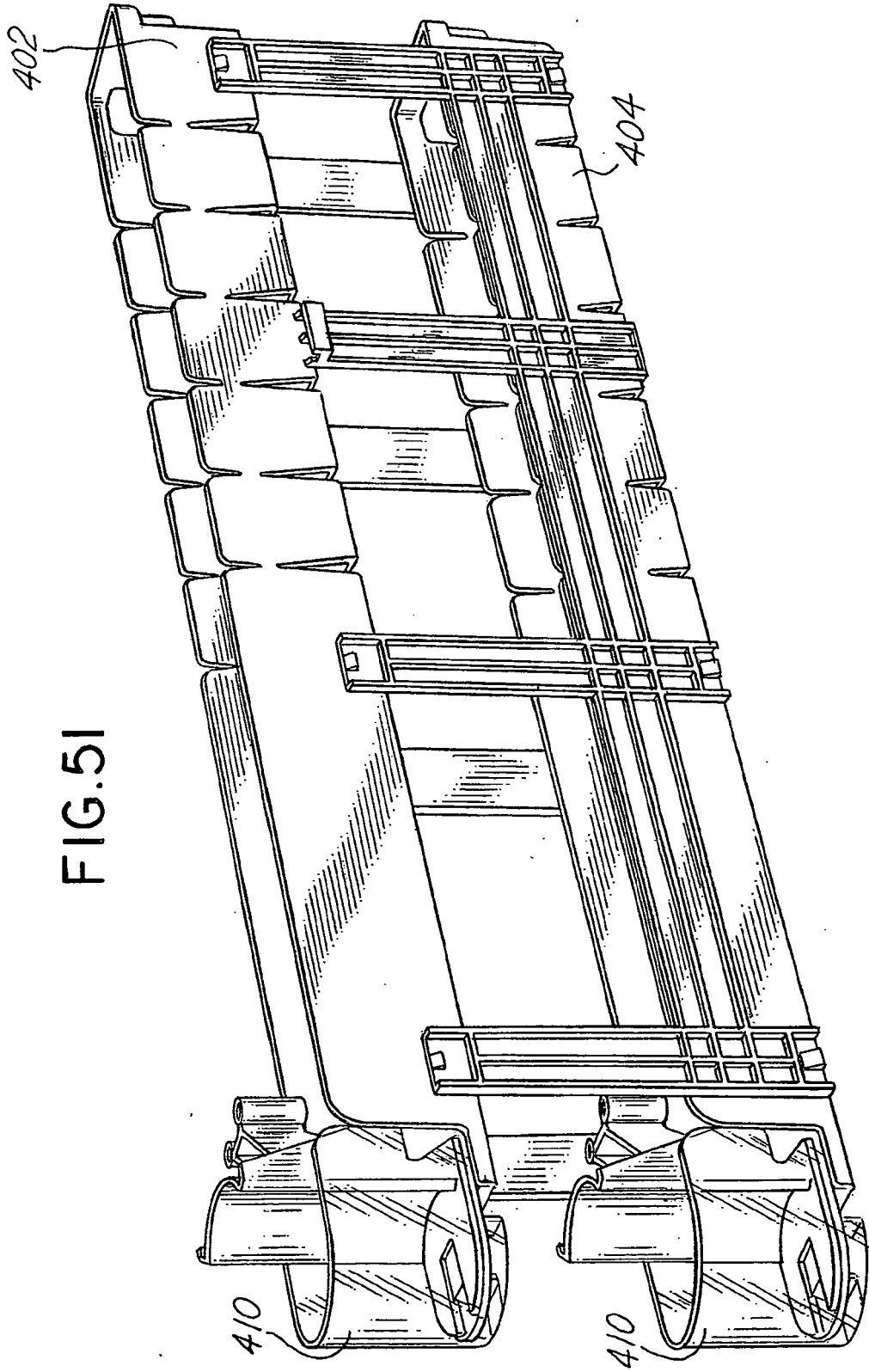
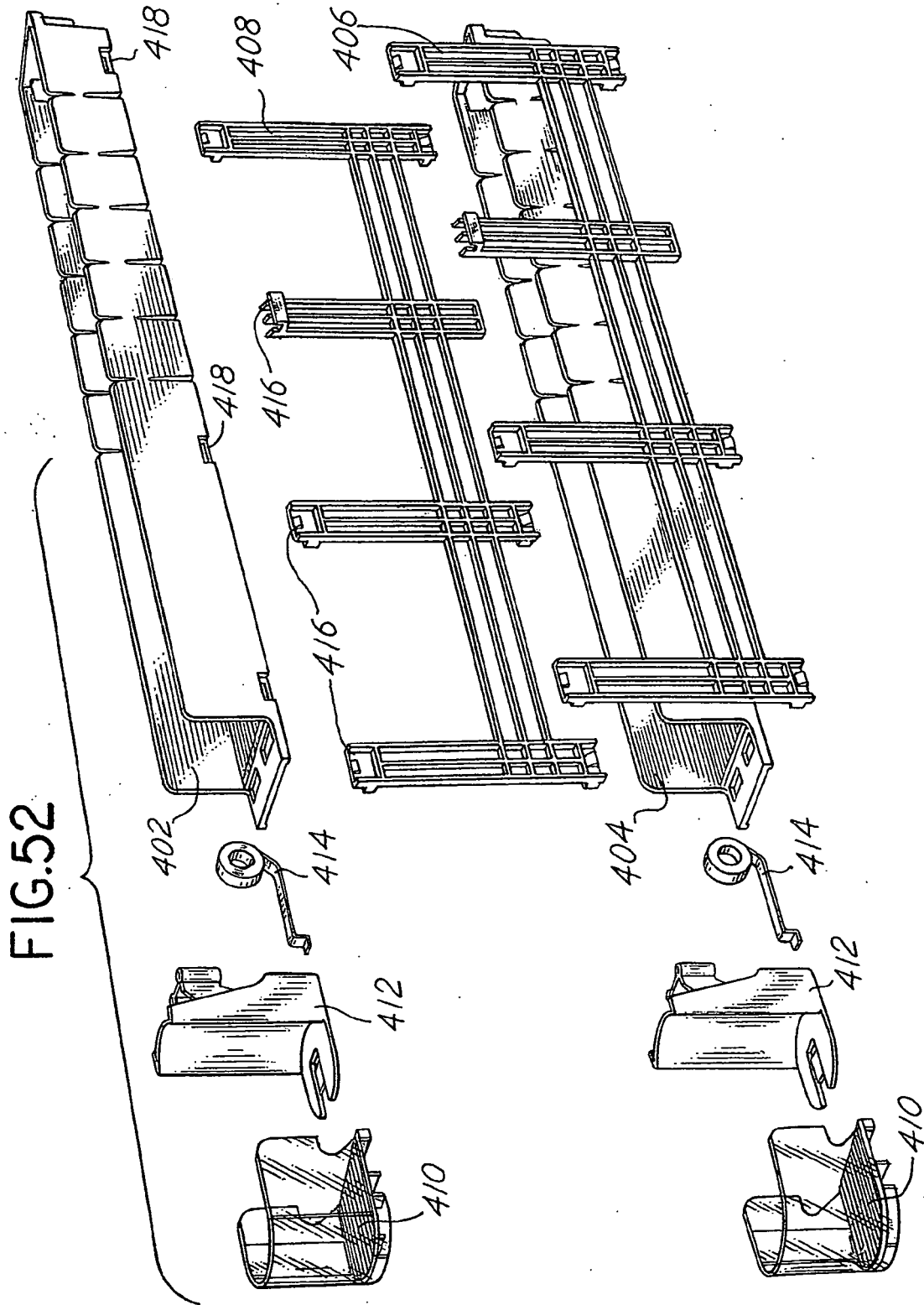

FIG. 51



**REFERENCES CITED IN THE DESCRIPTION**

*This list of references cited by the applicant is for the reader's convenience only. It does not form part of the European patent document. Even though great care has been taken in compiling the references, errors or omissions cannot be excluded and the EPO disclaims all liability in this regard.*

**Patent documents cited in the description**

- US 20050199564 A [0006]
- US 11257718 B [0037]