



- (51) International Patent Classification:  
*B23B 31/117* (2006.01)      *B23B 31/20* (2006.01)
- (21) International Application Number:  
PCT/IL2018/050758
- (22) International Filing Date:  
11 July 2018 (11.07.2018)
- (25) Filing Language: English
- (26) Publication Language: English
- (30) Priority Data:  
15/664,537      31 July 2017 (31.07.2017)      US
- (71) Applicant: ISCAR LTD. [IL/IL]; P.O. Box 11, 24959 Tefen (IL).
- (72) Inventors: SHAHEEN, Philip; P. O. Box 5239, 21550 Tarshiha (IL). FISHER, Raz; 119 Hazait Street, Karkom, 1292600 (IL).
- (74) Agent: SAVAGE, Nicholas et al.; Iscar Ltd., Patent Department, P.O. Box 11, 24959 Tefen (IL).
- (81) Designated States (unless otherwise indicated, for every kind of national protection available): AE, AG, AL, AM, AO, AT, AU, AZ, BA, BB, BG, BH, BN, BR, BW, BY, BZ, CA, CH, CL, CN, CO, CR, CU, CZ, DE, DJ, DK, DM, DO, DZ, EC, EE, EG, ES, FI, GB, GD, GE, GH, GM, GT, HN, HR, HU, ID, IL, IN, IR, IS, JO, JP, KE, KG, KH, KN, KP, KR, KW, KZ, LA, LC, LK, LR, LS, LU, LY, MA, MD, ME, MG, MK, MN, MW, MX, MY, MZ, NA, NG, NI, NO, NZ, OM, PA, PE, PG, PH, PL, PT, QA, RO, RS, RU, RW, SA, SC, SD, SE, SG, SK, SL, SM, ST, SV, SY, TH, TJ, TM, TN, TR, TT, TZ, UA, UG, US, UZ, VC, VN, ZA, ZM, ZW.
- (84) Designated States (unless otherwise indicated, for every kind of regional protection available): ARIPO (BW, GH, GM, KE, LR, LS, MW, MZ, NA, RW, SD, SL, ST, SZ, TZ, UG, ZM, ZW), Eurasian (AM, AZ, BY, KG, KZ, RU, TJ, TM), European (AL, AT, BE, BG, CH, CY, CZ, DE, DK, EE, ES, FI, FR, GB, GR, HR, HU, IE, IS, IT, LT, LU, LV,

(54) Title: TOOL HOLDER HAVING CAPTIVE NON-RELEASABLE MEMBERS, METHOD OF MANUFACTURE AND ASSEMBLY OF SAME AND CUTTING TOOL

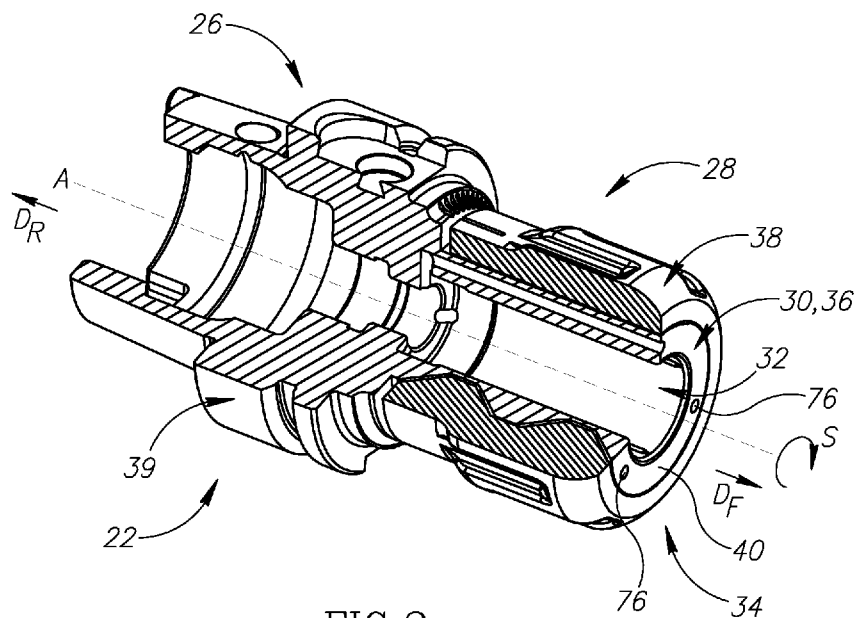

FIG. 2

(57) Abstract: A cutting tool includes a tool holding system (12, 122) having a clamping portion (28). The clamping portion (28) includes an integrally formed one-piece inner coupling member (36) that at least partially forms a clamping sleeve portion (30) having a clamping bore (32) for clampingly receiving a cutting insert (24). The clamping portion (28) also includes an integrally formed one-piece outer coupling member (38) that is circumferentially disposed about at least a portion of the inner coupling member (36). The tool holding system (12) also has a mounting portion (26) that is connected to one of the inner and outer coupling members (36; 38). The inner and outer coupling members (36; 38) are captively and non-releasably engaged with each other via inter-engaged first and second engagement surfaces (56, 58) that are slidingly displaceable with respect to each other.



MC, MK, MT, NL, NO, PL, PT, RO, RS, SE, SI, SK, SM,  
TR), OAPI (BF, BJ, CF, CG, CI, CM, GA, GN, GQ, GW,  
KM, ML, MR, NE, SN, TD, TG).

**Published:**

- *with international search report (Art. 21(3))*
- *before the expiration of the time limit for amending the claims and to be republished in the event of receipt of amendments (Rule 48.2(h))*

TOOL HOLDER HAVING CAPTIVE NON-RELEASABLE MEMBERS, METHOD OF MANUFACTURE AND  
ASSEMBLY OF SAME AND CUTTING TOOL**FIELD OF THE INVENTION**

5

The subject matter of the present application relates to tool holding systems, in general, and to such tool holding systems having parts that are captively and non-releasably engaged, in particular, and to such parts being manufactured by additive manufacturing further in particular.

10

**BACKGROUND OF THE INVENTION**

Tool holding systems can be provided with a clamping portion having a clamping bore for clampingly receiving a cutting insert therein. Typically, in rotary cutting tools, the clamping bore is formed in a clamping sleeve that undergoes an inward radial displacement (i.e. diameter shrinkage) thereby clampingly engaging the cutting insert located in the clamping bore. The inward radial displacement can be actuated by a tightening member, such as a tightening nut.

In some such tool holding systems said diameter shrinkage can be achieved by providing eccentric surface(s) on the clamping sleeve that are urged radially inwardly by tightening of the tightening member.

In some other such tool holding systems the clamping sleeve can be formed by a conical collet, for example, a standard ER collet. Examples of such tool holding systems, are disclosed in, for example, US 4,699,388 and US 8,118,312. Optionally, to allow precise alignment of the collet, the collet can be detachably connected to an annular collet ring that is rotatably connected to the tightening nut. Examples of such tool holding systems are disclosed in, for example, US 5,522,605 and US 5,911,421, where the collet ring is rotatably connected to the tightening nut via ball bearings.

It is an object of the subject matter of the present application to provide a new and improved tool holding system.

It is another object of the subject matter of the present application to provide a tool holding system with inner and outer coupling members that are captively and non-releasably engaged with each other.

It is yet another object of the subject matter of the present application to provide a new and improved cutting tool.

It is yet another object of the subject matter of the present application to provide a new and improved method of manufacture and assembly of a tool holding system.

5

### SUMMARY OF THE INVENTION

In accordance with a first aspect of the subject matter of the present application there is provided a tool holding system, having a tool holding system central axis defining opposite  
10 forward and rear directions, the tool holding system comprising:

a clamping portion comprising:

an integrally formed one -piece inner coupling member forming at least part  
of a clamping sleeve portion having a clamping bore, for clampingly receiving a  
cutting insert, the clamping bore opening out at a forward end of the tool holding  
15 system, the inner coupling member having a radially outwardly facing a first  
engagement surface; and

an integrally formed one-piece outer coupling member having a radially  
inwardly facing second engagement surface; and

a mounting portion connected to one of the inner and outer coupling members; wherein  
20 the outer coupling member is circumferentially disposed about at least a portion of the  
inner coupling member, with the first engagement surface facing the second engagement surface;  
the inner and outer coupling members are captively and non-releasably engaged with each  
other; and

the first and second engagement surfaces are slidingly displaceable with respect to each  
25 other to adjust the inner and outer coupling members between locked and released positions.

In accordance with a second aspect of the subject matter of the present application there is provided a cutting tool comprising:

a tool holding system of the type described above; and

a cutting insert located in the clamping bore and clampingly engaged therein.

30 In accordance with a third aspect of the subject matter of the present application there is provided a method of manufacture and assembly of a tool holding system of the type described above, comprising:

manufacturing the mounting portion;

manufacturing, by using an additive manufacturing process, a clamping head part comprising:

the inner and outer coupling members;

5 at least one connecting portion connecting the inner and outer coupling members;

an annular separation cavity bounded by the inner and outer coupling members and

the at least one connecting portion; and

a clamping head bore opening out to at least the clamping head forward end surface of the clamping head part;

10 separating the clamping head part into the inner and outer coupling members; and

connecting the clamping head part to the mounting portion.

It is understood that the above-said is a summary, and that features described hereinafter may be applicable in any combination to the subject matter of the present application, for example,  
15 any of the following features may be applicable to the tool holding system or the cutting tool or the method of manufacture and assembly:

The first and second engagement surfaces can extend circumferentially about the tool holding system central axis. The first and second engagement surfaces can be slidingly displaceable with respect to each other in a circumferential direction about the tool holding system  
20 central axis.

The first and second engagement surfaces can be slidingly displaceable with respect to each other in the circumferential direction by no more than 50°.

The first engagement surface can comprise at least one engagement recess recessed therein. The second engagement surface can comprise at least one engagement projection projecting  
25 therefrom. Each engagement projection can be located in a respective engagement recess.

The at least one engagement projection can comprise a plurality of angularly spaced apart engagement projections arranged in at least one axial projection row. The at least one engagement recess can comprise a plurality of angularly spaced apart engagement recesses arranged in at least one axial recess row.

30 Each engagement recess can comprise a central recess bottom surface. Each recess bottom surface can comprise a recess clearance surface and a recess abutment surface adjacent thereto in

the circumferential direction. The recess abutment surface can be located further from the tool holding system central axis than the recess clearance surface.

Each engagement projection can comprise a central projection top surface. Each projection top surface can have a constant radial distance from the tool holding system central axis.

5 The first engagement surface can comprise at least one engagement projection projecting therefrom. The second engagement surface can comprise at least one engagement recess recessed therein. Each engagement projection can be located in a respective engagement recess.

The first engagement surface can be located on the inner coupling member and face radially outwardly. The second engagement surface can be located on the outer coupling member and face  
10 radially inwardly.

The outer coupling member can form a tightening nut.

The inner coupling member can be integrally connected with the mounting portion forming a tool body having a one-piece construction.

The outer coupling member can comprise a radially inwardly facing outer threaded portion.  
15 The mounting portion can comprise a radially outwardly facing mounting threaded portion. The outer threaded portion can be threadingly engaged to the mounting threaded portion.

The inner coupling member can form in entirety the clamping sleeve portion.

The inner coupling member can form a sliding collet ring. The clamping sleeve portion can further comprise a collet that is releasably attached to the inner coupling member. The  
20 clamping bore can be located in the collet.

The tool holding system can further comprise at least one coolant channel opening out at the forward end of the tool holding system.

Each coolant channel can be formed in the inner coupling member and extend an entire axial length thereof.

25 The inner coupling member can comprise at least one axially extending coolant ridge. Each coolant channel can be located in a coolant ridge.

The first engagement surface can comprise a plurality of angularly spaced apart engagement recesses. Members of each pair of circumferentially adjacent engagement recesses can be separated by a respective coolant ridge.

The inner coupling member can comprise a coolant groove that extends the entire axial length of the inner coupling member. Each coolant channel can be formed by the coolant groove and the outer coupling member.

Each projection top surface can abut a respective recess abutment surface.

5 The method can comprise manufacturing the clamping head part to have exactly two connecting portions connecting the inner and outer coupling members so that the separation cavity can be entirely closed.

The step of separating the clamping head part into the inner and outer coupling members can comprise removing the at least one connecting portion.

10 The step of removing the at least one connecting portion can comprise:

- i) in the clamping head part, face grooving a separation groove which extends to the separation cavity; or
- ii) grinding the clamping head part to the separation cavity; or
- iii) in the clamping head part, external grooving a separation groove which extends to  
15 the separation cavity; or
- iv) in the clamping head bore, internal grooving a separation groove which extends to the separation cavity.

The method can comprise manufacturing the mounting portion with a non-additive manufacturing process.

20 The method can comprise manufacturing the mounting portion with an additive manufacturing process.

The method can comprise connecting the clamping head part to the mounting portion by additively manufacturing the clamping head part directly onto the mounting portion.

25 The method can comprise connecting the clamping head part to the mounting portion by manufacturing the mounting portion and the clamping head part together in a single additive manufacturing process.

The method can comprise manufacturing the mounting portion and the clamping head part separately. Then connecting the clamping head part to the mounting portion.

The method can further comprise:

30 releasably attaching a collet to the inner coupling member after separating the clamping head part into the inner and outer coupling members; wherein:

connecting the clamping head part to the mounting portion comprises threadingly attaching the outer coupling member to the mounting portion after releasably attaching the collet to the inner coupling member.

5

### BRIEF DESCRIPTION OF THE FIGURES

For a better understanding of the present application and to show how the same may be carried out in practice, reference will now be made to the accompanying drawings, in which:

**Fig. 1** is a perspective view of a cutting tool in accordance with a first embodiment of the present application;

**Fig. 2** is a perspective view of a tool holding system, partially cut away, in accordance with the first embodiment of the present application;

**Fig. 3** is a perspective view of an inner coupling member shown in Fig. 2;

**Fig. 4** is a perspective view of an outer coupling member, partially cut away, shown in Fig. 2;

**Fig. 5** is an axial cross-sectional view of the tool holding system shown in Fig. 2;

**Fig. 6a** is an axially perpendicular cross-sectional view taken along the line VIa-VIa in Fig. 5, when the tool holding system is in a released position;

**Fig. 6b** is an analogous view of Fig. 6a, when the tool holding system is in a locked position;

**Fig. 7** is a perspective view of a mounting portion and a separate clamping head part in accordance with the first embodiment of the present application;

**Fig. 8** is a perspective view of the clamping head part connected to the mounting portion;

**Fig. 9** is a perspective view of the clamping head part, partially cut away, showing the inner and outer coupling members before separation;

**Fig. 10** is an analogous view of Fig. 9, after separation of the inner and outer coupling members;

**Fig. 11** is a perspective view of the cutting tool, partially cut away, in accordance with a second embodiment of the present application;

**Fig. 12** is a perspective view of a clamping portion of the tool holding system, with a cut away section, in accordance with the second embodiment of the present application;

**Fig. 13** is a perspective view of the inner coupling member shown in Fig. 12;

**Fig. 14** is a perspective view of the outer coupling member, partially cut away, shown in Fig. 12;

**Fig. 15** is a front view of the clamping portion shown in Fig. 12;

**Fig. 16** is a cross-sectional view taken along the line XVII-XVII in Fig. 15;

5 **Fig. 17** is a perspective view of the clamping head part, partially cut away, showing the inner and outer coupling members before separation;

**Fig. 18** is a detail of Fig. 17 indicated by "XVIII"; and

**Fig. 19** is an analogous view of Fig. 17, after separation the inner and outer coupling members.

10

It will be appreciated that for simplicity and clarity of illustration, elements shown in the figures have not necessarily been drawn to scale. For example, the dimensions of some of the elements may be exaggerated relative to other elements for clarity, or several physical components may be included in one functional block or element. Further, where considered appropriate, reference numerals may be repeated among the figures to indicate corresponding or analogous elements.

15

## DETAILED DESCRIPTION OF THE INVENTION

20

In the following description, various aspects of the subject matter of the present application will be described. For purposes of explanation, specific configurations and details are set forth in sufficient detail to provide a thorough understanding of the subject matter of the present application. However, it will also be apparent to one skilled in the art that the subject matter of the present application can be practiced without the specific configurations and details presented herein.

25

Attention is first drawn to Fig. 1 showing a cutting tool **20, 120**, for chip removal, depicting an aspect of the present application. In this non-limiting example shown in the drawings, the cutting tool **20, 120** is a rotary cutting tool. In particular, the rotary cutting tool is a drilling tool, suitable for drilling cutting operations. However, the subject matter of the present application is not restricted only to drilling cutters and could also be applicable to, for example but not limited to, milling tools. Moreover, the cutting tool **20, 120** could be a non-rotary cutting tool, such as, but not limited to, a turning tool. The cutting tool **20, 120** has a tool longitudinal axis **C**. In

30

accordance with some embodiments of the subject matter of the present application, the cutting tool **20, 120** can be rotatable in a direction of rotation **R** about the tool longitudinal axis **C**. The cutting tool **20, 120** includes a tool holding system **22, 122**. The cutting tool **20, 120** also includes a cutting insert **24** clampingly engaged to the tool holding system **22, 122**. The cutting insert **24** is designed to perform metal cutting operations and has a cutting edge (not shown) for the purpose thereof. In this non-limiting example shown in the drawings, the cutting insert **24** is a drill bit.

Reference is now made to Fig. 2, showing the tool holding system **22, 122**, depicting another aspect of the present application. The tool holding system **22, 122** has a tool holding system central axis **A**. The tool holding system central axis **A** defines opposite forward and rear directions **D<sub>F</sub>, D<sub>R</sub>**. In accordance with some embodiments of the subject matter of the present application, the tool holding system central axis **A** can be co-incident with the tool longitudinal axis **C**.

It should be noted that use of the terms "forward" and "rearward" throughout the description and claims refer to a relative position in a direction of the tool holding system central axis **A** towards the left and right, respectively, in Figs. 5 and 16. In the present disclosure, "forward" is associated with the cutting end of the cutting tool **20, 120**. It should further be noted that use of the terms "axial" and "radial" throughout the description and claims are with respect to the tool holding system central axis **A**, unless otherwise stated.

The tool holding system **22, 122** includes a mounting portion **26** and a clamping portion **28** connected thereto. In the case of rotary cutting tools, for example, the mounting portion **26** is designed to be connected to a torque transferring system (such as a spindle, not shown) in order to rotate the cutting tool **20, 120**.

Referring to Fig. 2, the clamping portion **28** includes an integrally formed one-piece inner coupling member **36, 136**. The clamping portion **28** also includes an integrally formed one-piece outer coupling member **38, 138**. The outer coupling member **38, 138** is circumferentially disposed about at least a portion of the inner coupling member **36, 136**.

The mounting portion **26** is connected to one of the inner and outer coupling members **36, 136; 38, 138**. In accordance with the first embodiment of the subject matter of the present application, the inner coupling member **36** can be integrally connected with the mounting portion **26** forming a tool body **39** having a one-piece construction.

Referring now to Fig. 3, the inner coupling member **36, 136** forms at least part of a clamping sleeve portion **30** which includes a clamping bore **32**. The clamping bore **32** is designed for clampingly receiving a cutting insert **24**. The clamping bore **32** opens out at a forward end **34** of the tool holding system **22, 122**. In accordance with some embodiments of the subject matter of the present application, the inner coupling member **36, 136** can include two opposite (forward and rear) inner end surfaces **40, 41** and an inner peripheral surface **42** extending therebetween. The inner peripheral surface **42** can extend circumferentially about the tool holding system central axis **A**. The inner coupling member **36, 136** can include an inner bore **44** that can open out at least to the forward inner end surface **40**. The inner bore **44** can be defined by an inner bore wall surface **46**. It is noted that in the configuration where the inner coupling member **36** is integrally connected with the mounting portion **26**, the rear inner end surface **41** is an imaginary surface that is located where the mounting portion **26** merges (i.e. transitions) into the inner coupling member **36**.

In accordance with the first embodiment of the subject matter of the present application, the inner coupling member **36** can form in entirety the clamping sleeve portion **30**. That is to say, the clamping sleeve portion **30** is formed from no other part except the inner coupling member **36**. Advantageously, this provides for a tool holding system **22** with only two distinct parts, with no need for assembly with additional parts. In such a configuration, the inner bore **44** can form the clamping bore **32**. The inner coupling member **36** can include an inner base portion **49** at a rear end thereof. The inner base portion **49** can define the maximum radial dimension of the inner coupling member **36**. The outer coupling member **38** can be circumferentially disposed about a portion of the inner coupling member **36** that does not include the inner base portion **49**.

Referring now to Fig. 4, in accordance with some embodiments of the subject matter of the present application the outer coupling member **38, 138** can include two opposite (forward and rear) outer end surfaces **48** and an outer peripheral surface **50** extending therebetween. The outer peripheral surface **50** can extend circumferentially about the tool holding system central axis **A**. The outer coupling member **38, 138** can include an outer through bore **52** that can extend between, and open out to, the two outer end surfaces **48**. The outer through bore **52** can be defined by an outer through bore wall surface **53** that faces radially inwardly. The inner coupling member **36, 136** can be located at least partially in the outer through bore **52**. The outer coupling member **38, 138** can form a tightening nut **54**.

Referring to Figs 3 and 4, the inner coupling member **36, 136** has a radially outwardly facing first engagement surface **56, 58**. while the outer coupling member **38, 138** has a radially inwardly facing second engagement surface **58**. The first and second engagement surfaces **56, 58** can extend around the entire circumferential extent of the inner or outer coupling member **36, 136; 38, 138** upon which it is located. As shown in Fig. 2, the inner and outer coupling members **36, 136; 38, 138** are captively and non-releasably engaged via inter-engaged first and second engagement surfaces **56, 58**. The first and second engagement surfaces **56, 58** are slidingly displaceable with respect to each other to adjust the inner and outer coupling members between locked and released positions.

In accordance with some embodiments of the subject matter of the present application, the first and second engagement surface **56, 58** can extend circumferentially about the tool holding system central axis **A**. The first and second engagement surfaces **56, 58** can face each other. The first and second engagement surfaces **56, 58** can be slidingly displaceable with respect to each other in a circumferential direction **S** about the tool holding system central axis **A**. Thus, the first and second engagement surfaces **56, 58** can be slidingly rotatable with respect to each other. The circumferential direction **S** and the direction of rotation **R** can be co-directional.

In accordance with the first embodiment of the subject matter of the present application, the inner coupling member's first engagement surface **56** can include at least one engagement recess **62** recessed therein. The outer coupling member's second engagement surface **58** can include at least one radially inwardly facing engagement projection **60** projecting therefrom. Referring to Figs. 2 and 5, each engagement projection **60** can be located in a respective engagement recess **62**. Thus, the first and second engagement surfaces **56, 58** can be inter-engaged.

As seen in Fig. 3, in accordance with the first embodiment of the subject matter of the present application, the at least one engagement projection **60** can include a plurality of angularly spaced apart engagement projections **60** arranged in at least one axial projection row. The at least one engagement recess **62** can include a plurality of angularly spaced apart engagement recesses **62** arranged in at least one axial recess row. In the non-limiting example shown in the drawings, there are exactly two axial projection rows and two axial recess rows.

Each engagement recess **62** can include two angularly spaced apart recess side walls **64** and a central recess bottom surface **66** that extends therebetween. Each recess bottom surface **66**

can include a recess clearance surface **68** and a recess abutment surface **70**. The recess abutment surface **70** can be adjacent to the recess clearance surface **68** in the circumferential direction **S**. As seen in Figs. 3, 6a and 6b, the recess abutment surface **70** can be located further from the tool holding system central axis **A** than the recess clearance surface **68** in the radial direction. Each engagement recess **62** can include two opposite axially spaced apart recess axial side walls **65**.

As seen in Fig. 4, each engagement projection **60** can include two angularly spaced apart projection side walls **72** and a central projection top surface **74** that extends therebetween. Each projection top surface **74** can have a constant radial distance **D** from the tool holding system central axis **A**. Each engagement projection **60** can include two opposite axially spaced apart projection axial side walls **73**. Contact between one or more of the recess axial side walls **65** and one or more of the projection axial side walls **73** prevent axial displacement of the outer coupling member **38**, **138** with respect to the inner coupling member **36**, **136**.

Reverting to Fig. 3, in accordance with the first embodiment of the subject matter of the present application, the radially outwardly facing first engagement surface **56** can be located on the inner peripheral surface **42** of the inner coupling member **36**. And as seen in Fig. 4, the radially inwardly facing second engagement surface **58** can be located on the outer through bore wall surface **53** of the outer coupling member **38**.

Referring to Figs. 2 and 5, in accordance with some embodiments of the subject matter of the present application, the tool holding system **22**, **122** can include at least one coolant channel **76** that opens out at the forward end **34** of the tool holding system **22**, **122**. The coolant channel **76** is designed to allow delivery of a cooling fluid to the cutting portion of the cutting insert **24**.

In accordance with the first embodiment of the subject matter of the present application, each coolant channel **76** can be formed in the inner coupling member **36** and extend an entire axial length thereof. Each coolant channel **76** can open out to the forward inner end surface **40**. The inner coupling member **36** can include at least one axially coolant ridge **78**. Each coolant ridge **78** can extend in the axial direction. Each coolant channel **76** can be located in a coolant ridge **78**. Members of each pair of circumferentially adjacent engagement recesses **62** can be separated by a respective coolant ridge **78**.

The tool holding system **22**, **122** is adjustable between a released and locked position. In the released position of the tool holding system **22**, **122**, the clamping bore **32** has clearance to allow the cutting insert **24** to be inserted therein. In the locked position of the tool holding system

**22, 122**, the cutting insert **24** is located in the clamping bore **32** and clampingly engaged therein, forming the cutting tool **20, 120**.

In accordance with the first embodiment of the subject matter of the present application, to adjust the tool holding system **22, 122** between a released and locked position the first and second engagement surfaces **56, 58** can be slidably displaced with respect to each other in the circumferential direction **S** about the tool holding system central axis **A** by no more than 50°. Further rotation can be prevented by contact between the projection and recess side walls **72, 64**. Alternatively, rotation can be prevented by tight abutment between projection top surface **74** and a respective recess abutment surface **70**.

As mentioned earlier in the description, one aspect of the present invention relates to the cutting tool **20, 120**, where the cutting insert **24** is located in the clamping bore **32** and clampingly engaged therein. When the tool holding system **22** is in the locked position, in accordance with the first embodiment of the subject matter of the present application, each projection top surface **74** can abut a respective recess abutment surface **70**. Thus, the clamping sleeve portion **30** is urged in the radial inward direction so that the cutting insert **24** is clampingly engaged in the clamping bore **32**.

A third aspect of the present application includes a method of manufacture and assembly of the tool holding system **22, 122**. Reference is made to Fig. 7, showing a clamping head part **80** and the mounting portion **26** in accordance with the first embodiment, although the method is also applicable for the other embodiments. The method includes manufacturing the mounting portion **26**. In accordance with some embodiments of the subject matter of the present application, the step of manufacturing the mounting portion **26** can include a non-additive manufacturing process. Alternatively, the step of manufacturing the mounting portion **26** can include an additive manufacturing process.

It should also further be noted that use of the term "additive manufacturing process" throughout the description and claims refers to processes used to create a three-dimensional object in which layers of material are formed to create an object. Examples of such processes include, but are not limited to, Selective Laser Melting (SLM), Selective Laser Sintering (SLS), Direct Metal Laser Sintering (DMLS), Fused Deposition Modeling (FDM) and 3D Printing.

The method includes the step of manufacturing the clamping head part **80, 180**, by using an additive manufacturing process. The clamping head part **80, 180** includes clamping head

forward and rear end surfaces **82, 84** and a clamping head peripheral surface **86** that extends therebetween. The clamping head part **80, 180** includes a clamping head bore **88**, recessed in, and opening out to, at least the clamping head forward end surface **82**. The clamping head bore **88** can open out to the clamping head forward and rear end surface **82, 84**. The clamping head bore **88** is defined by a clamping head bore wall surface **90**. The clamping head part **80, 180** is formed from the inner and outer coupling members **36, 136; 38, 138** which are connected by at least one connecting portion **92**. Each connecting portion **92** can be annular in shape. Each connecting portion **92** can be located at an axial end (i.e. forward or rear end) of one or both of the inner and outer coupling members **36, 136; 38, 138**. The clamping head bore **88** corresponds to the inner bore **44**. The clamping head peripheral surface **86** corresponds to the outer peripheral surface **50** and optionally a portion of the inner peripheral surface **42**.

It is noted that, except in the case where the clamping head part **80** is manufactured directly onto the mounting portion **26** (as described further on in the description), the order of two steps (i.e. manufacturing the mounting portion **26** and the clamping head part **80**) can be swapped. It is also noted that in such a case, one of the clamping head forward end surfaces **82** is an imaginary surface that is located where the mounting portion **26** merges (i.e. transitions) into the clamping head part **80**.

Referring to Fig. 9, the clamping head part **80, 180** includes an annular separation cavity **94** that is bounded by the inner and outer coupling members **36, 136; 38, 138** and the at least one connecting portion **92**. The first and second engagement surfaces **56, 58** are spaced apart by the separation cavity **94**. Thus, the shape of the separation cavity **94** is laterally defined by the shape of the first and second engagement surfaces **56, 58**. Optionally, the inner and outer coupling members **36, 136; 38, 138** can be connected by exactly two connecting portions **92** so that the separation cavity **94** is entirely closed. The separation cavity **94** can have a slit-like shape.

Referring to Fig. 10, the method includes separating the clamping head part **80, 180** into the inner and outer coupling members **36, 136; 38, 138**. In accordance with some embodiments of the subject matter of the present application, the step of separating the clamping head part **80, 180** can include removing the at least one connecting portion **92**. The step of removing the at least one connecting portion **92** can include one of the following: i) in the clamping head part **80, 180**, face grooving a separation groove **96** which extends to the separation cavity **94**, or ii) grinding the clamping head part **80, 180** to the separation cavity **94**, or iii) in the clamping head part **80,**

**180**, external grooving a separation groove **96** which extends to the separation cavity **94**, or iv) in the clamping head part **80, 180**, internal grooving a separation groove **96** which extends to the separation cavity **94**.

The method further includes the step of connecting the clamping head part **80, 180** to the mounting portion **26** either i) during or after the step of manufacturing the clamping head part **80, 180** or ii) after the step separating the clamping head part **80, 180**.

Referring to Fig. 8, in accordance with the first embodiment of the subject matter of the present application, the step of connecting the clamping head part **80** to the mounting portion **26** can be performed during the step of manufacturing the clamping head part **80** by additively manufacturing the clamping head part **80** directly onto the mounting portion **26**. Moreover, when the mounting portion **26** is additively manufactured, the mounting portion **26** and the clamping head part **80** can be manufactured together in a single additive manufacturing process. Alternatively, the mounting portion **26** and the clamping head part **80** can be manufactured separately. The step of connecting the clamping head part **80** to the mounting portion **26** can include for example, brazing the parts together.

A second embodiment of the invention is described below. As seen in Fig. 12, the outer coupling member **138** can be circumferentially disposed about the entire inner coupling member **136**. Referring to Figs. 13 to 16, the at least one engagement recess **62** can include an annular groove **108**. The at least one engagement projection **60** can include an annular ridge **110**. The first engagement surface **56** can be located on the inner coupling member **136** and face radially outwardly. Specifically, the first engagement surface **56** can be located on the inner peripheral surface **42**. The second engagement surface **58** can be located on the outer coupling member **138** and face radially inwardly. Specifically, the second engagement surface **58** can be located on the outer through bore wall surface **53**.

Reverting to Fig. 12, the inner coupling member **136** can form a sliding collet ring **102** which is directly slidingly displaceable with respect to the tightening nut **54**. Advantageously, this provides for a tool holding system **22** with no need for post-assembly with additional parts, such as ball bearings. In such a configuration, the inner bore **44** can form the clamping bore **32**. The inner bore **44** can open out to both of the two opposite inner end surfaces **40, 41** forming a ring through bore **104**. The clamping portion **28** can further include a collet **106**. The clamping bore

**32** can be located in the collet **106**. The collet **106** can be releasably attached to the sliding collet ring **102** at the ring through bore **104**.

As seen in Fig. 13, in accordance with the second embodiment of the subject matter of the present application, the inner coupling member **136** can include a coolant groove **114** that extends the entire axial length of the inner coupling member **136**. For example, coolant groove **114** can be located in the inner peripheral surface **42**. Each coolant channel **76** can be formed by the coolant groove **114** and the outer coupling member **138**. Alternatively, each coolant channel **76** can be formed by the coolant groove **114** and the cutting insert **24**.

In accordance with the second embodiment of the subject matter of the present application, to adjust the tool holding system **122** between a released and locked position, the collet **106** is urged in the radial inward direction via a conical receiving bore **112**, by turning the tightening nut **54** (i.e., the outer coupling member **138**), so that the cutting insert **24** is clampingly engaged in the clamping bore **32** as shown in Fig. 11 (as is well known in the art).

Reference is now made to Fig. 11. The outer coupling member **138** can include a radially inwardly facing outer threaded portion **98**. The mounting portion **26** can include a radially outwardly facing mounting threaded portion **100**. The method can further include releasably attaching a collet **106** to the inner coupling member **136** after separating the clamping head part **180** into the inner and outer coupling members **136**, **138**. The step of connecting the clamping head part **80** to the mounting portion **26** can include threadingly attaching the outer coupling member **138** to the mounting portion **26** after the step of releasably attaching the collet **106** to the inner coupling member **136**.

It should be noted that one feature of the subject matter of the present application is that since the inner and outer coupling members **36**, **136**; **38**, **138** are captively and non-releasably engaged, the tool holding system **22**, **122** has no falling parts when, example, replacing the cutting insert **24** or the collet **106**. Thus, generally speaking, the inner and outer coupling members cannot be separated from another without damaging at least one of the members.

It can be seen from the foregoing that in one embodiment the least one engagement recess **62** is formed on the inner coupling member **36** while in the other embodiment the at least one engagement recess **62** is formed on the outer coupling member **138**, with the at least one projection **60** being formed on the other coupling member.

Although the subject matter of the present application has been described to a certain degree of particularity, it should be understood that various alterations and modifications could be made without departing from the spirit or scope of the invention as hereinafter claimed.

## CLAIMS

1. A tool holding system (22, 122), having a tool holding system central axis (A) defining opposite forward and rear directions ( $D_F$ ,  $D_R$ ), the tool holding system (22, 122) comprising:

a clamping portion (28) comprising:

an integrally formed one-piece inner coupling member (36, 136) forming at least part of a clamping sleeve portion (30) having a clamping bore (32), for clampingly receiving a cutting insert (24), the clamping bore (32) opening out at a forward end (34) of the tool holding system (22, 122), the inner coupling member (36, 136) having a radially outwardly facing a first engagement surface (56); and

an integrally formed one-piece outer coupling member (38, 138) having a radially inwardly facing second engagement surface (58); and

a mounting portion (26) connected to one of the inner and outer coupling members (36, 136; 38, 138); wherein

the outer coupling member (38, 138) is circumferentially disposed about at least a portion of the inner coupling member (36, 136), with the first engagement surface (56) facing the second engagement surface (58);

the inner and outer coupling members (36, 136; 38, 138) are captively and non-releasably engaged with each other; and

the first and second engagement surfaces (56, 58) are slidingly displaceable with respect to each other to adjust the inner and outer coupling members between locked and released positions.

2. The tool holding system (22, 122), according to claim 1, wherein:

the first and second engagement surfaces (56, 58) extend circumferentially about the tool holding system central axis (A); and

the first and second engagement surfaces (56, 58) are slidingly displaceable with respect to each other in a circumferential direction (S) about the tool holding system central axis (A).

3. The tool holding system (22), according to claim 2, wherein:

the first and second engagement surfaces (56, 58) are slidably displaceable with respect to each other in the circumferential direction (S) by no more than 50°.

4. The tool holding system (22, 122), according to any one of claims 1-3; wherein:
  - the first engagement surface (56) comprises at least one engagement recess (62) recessed therein;
  - the second engagement surface (58) comprises at least one engagement projection (60) projecting therefrom; and
  - each engagement projection (60) is located in a respective engagement recess (62).
  
5. The tool holding system (22), according to claim 4, wherein:
  - the at least one engagement projection (60) comprises a plurality of angularly spaced apart engagement projections (60) arranged in at least one axial projection row; and
  - the at least one engagement recess (62) comprises a plurality of angularly spaced apart engagement recesses (62) arranged in at least one axial recess row.
  
6. The tool holding system (22), according to claims 4 or 5; wherein:
  - each engagement recess (62) comprises a central recess bottom surface (66);
  - each recess bottom surface (66) comprises a recess clearance surface (68) and a recess abutment surface (70) adjacent thereto in the circumferential direction (S); and
  - the recess abutment surface (70) is located further from the tool holding system central axis (A) than the recess clearance surface (68) in the radial direction.
  
7. The tool holding system (22), according to claim 6, wherein:
  - each engagement projection (60) comprises a central projection top surface (74);
  - each projection top surface (74) has a constant radial distance (D) from the tool holding system central axis (A).
  
8. The tool holding system (122), according to claims 1 or 2, wherein:
  - the first engagement surface (56) comprises at least one engagement projection (60) projecting therefrom;

the second engagement surface (58) comprises at least one engagement recess (62) recessed therein; and

each engagement projection (60) is located in a respective engagement recess (62).

9. The tool holding system (122), according to claim 8, wherein:

the at least one engagement recess (62) comprises an annular groove (108); and

the at least one engagement projection (60) comprises an annular ridge (110).

10. The tool holding system (22, 122), according to any one of claims 1-9, wherein the outer coupling member (38, 138) forms a tightening nut (54).

11. The tool holding system (22), according to any one of claims 1-7 and 10, wherein the inner coupling member (36, 136) is integrally connected with the mounting portion (26) forming a tool body (39) having a one-piece construction.

12. The tool holding system (122), according to any one of claims 1-2 and 8-10, wherein:

the outer coupling member (138) comprises a radially inwardly facing outer threaded portion (98);

the mounting portion (26) comprises a radially outwardly facing mounting threaded portion (100); and

the outer threaded portion (98) is threadingly engaged to the mounting threaded portion (100).

13. The tool holding system (22), according to any one of claims 1-7 and 10-11, wherein the inner coupling member (36) forms in entirety the clamping sleeve portion (30).

14. The tool holding system (122), according to any one of claims 1-2, 8-10 and 12, wherein:  
the inner coupling member (136) forms a sliding collet ring (102);

the clamping sleeve portion (30) further comprises a collet (106) that is releasably attached to the inner coupling member (136); and

the clamping bore (32) is located in the collet (106).

15. The tool holding system (22, 122), according to any one of claims 1-15, further comprising at least one coolant channel (76) opening out at the forward end (34) of the tool holding system (22, 122).
16. The tool holding system (22), according to claim 15, wherein each coolant channel (76) is formed in the inner coupling member (36) and extends an entire axial length thereof.
17. The tool holding system (22), according to claim 16, wherein:  
the inner coupling member (36) comprises at least one axially extending coolant ridge (78);  
and  
each coolant channel (76) is located in a coolant ridge (78).
18. The tool holding system (22), according to claim 17, wherein:  
the first engagement surface (56) comprises a plurality of angularly spaced apart engagement recesses (62); and  
members of each pair of circumferentially adjacent engagement recesses (62) are separated by a respective coolant ridge (78).
19. The tool holding system (122), according to claim 15, wherein:  
the inner coupling member (136) comprises a coolant groove (114) that extends the entire axial length of the inner coupling member (136); and  
each coolant channel (76) is formed by the coolant groove (114) and the outer coupling member (138).
20. A cutting tool (20, 120), comprising:  
a tool holding system (22, 122) in accordance with any one of claims 1-19; and  
a cutting insert (24) located in the clamping bore (32) and clampingly engaged therein.
21. The cutting tool (20), according to claim 20 wherein:  
the first engagement surface (56) comprises at least one engagement recess (62);

the second engagement surface (58) comprises at least one engagement projection (60);  
each engagement projection (60) is located in a respective engagement recess (62);  
each engagement recess (62) comprises a central recess bottom surface (66);  
each recess bottom surface (66) comprises a recess clearance surface (68) and a recess abutment surface (70) adjacent thereto in the circumferential direction (S); and  
the recess abutment surface (70) is located further from the tool holding system central axis (A) than the recess clearance surface (68), in the radial direction;  
each engagement projection (60) comprises a central projection top surface (74);  
each projection top surface (74) has a constant radial distance (D) from the tool holding system central axis (A); and  
each projection top surface (74) abuts a respective recess abutment surface (70).

22. The cutting tool (20), according to claim 21 wherein:  
the inner coupling member (36) forms in entirety the clamping sleeve portion (30).
23. The cutting tool (120), according to claim 2020 wherein:  
the inner coupling member (136) forms a sliding collet ring (102);  
the clamping sleeve portion (30) further comprises a collet (106) that is releasably attached to the inner coupling member (136); and  
the clamping bore (32) is located in the collet (106).
24. A method of manufacture and assembly of a tool holding system (22, 122) in accordance with any one of claims 1-19, comprising:  
manufacturing the mounting portion (26);  
manufacturing, by using an additive manufacturing process, a clamping head part (80, 180) comprising:  
the inner and outer coupling members (36, 136; 38, 138);  
at least one connecting portion (92) connecting the inner and outer coupling members (36, 136; 38, 138);  
an annular separation cavity (94) bounded by the inner and outer coupling members (36, 136; 38, 138) and the at least one connecting portion (92); and

- a clamping head bore (88) opening out to at least the clamping head forward end surface (82) of the clamping head part (80, 180);  
separating the clamping head part (80, 180) into the inner and outer coupling members (36, 136; 38, 138); and  
connecting the clamping head part (80, 180) to the mounting portion (26).
25. The method according to claim 24, comprising manufacturing the clamping head part (80, 180) to have exactly two connecting portions (92) connecting the inner and outer coupling members (36, 136; 38, 138) so that the separation cavity (94) is entirely closed.
26. The method according to claims 24 or 25, wherein the step of separating the clamping head part (80, 180) into the inner and outer coupling members (36, 136; 38, 138) comprises removing the at least one connecting portion (92).
27. The method according to claim 26, wherein the step of removing the at least one connecting portion (92) comprises:
- i) in the clamping head part (80, 180), face grooving a separation groove (96) which extends to the separation cavity (94); or
  - ii) grinding the clamping head part (80, 180) to the separation cavity (94); or
  - iii) in the clamping head part (80, 180), external grooving a separation groove (96) which extends to the separation cavity (94); or
  - iv) in the clamping head bore (88), internal grooving a separation groove (96) which extends to the separation cavity (94).
28. The method according to any one of claims 24-27, comprising manufacturing the mounting portion (26) with a non-additive manufacturing process.
29. The method according to any one of claims 24-27, comprising manufacturing the mounting portion (26) with an additive manufacturing process.

30. The method according to any one of claims 24-29, comprising connecting the clamping head part (80) to the mounting portion (26) by additively manufacturing the clamping head part (80) directly onto the mounting portion (26).

31. The method, according to any one of claims 24-27 and 29, comprising connecting the clamping head part (80) to the mounting portion (26) by manufacturing the mounting portion (26) and the clamping head part (80) together in a single additive manufacturing process.

32. The method, according to any one of claim 24-30, comprising:  
manufacturing the mounting portion (26) and the clamping head part (80) separately; and  
then connecting the clamping head part (80) to the mounting portion (26).

33. The method, according to any one of claims 24-27, further comprising:  
releasably attaching a collet (106) to the inner coupling member (136) after separating the clamping head part (180) into the inner and outer coupling members (136, 138); wherein:  
connecting the clamping head part (180) to the mounting portion (26) comprises  
threadingly attaching the outer coupling member (138) to the mounting portion (26) after  
releasably attaching the collet (106) to the inner coupling member (136).

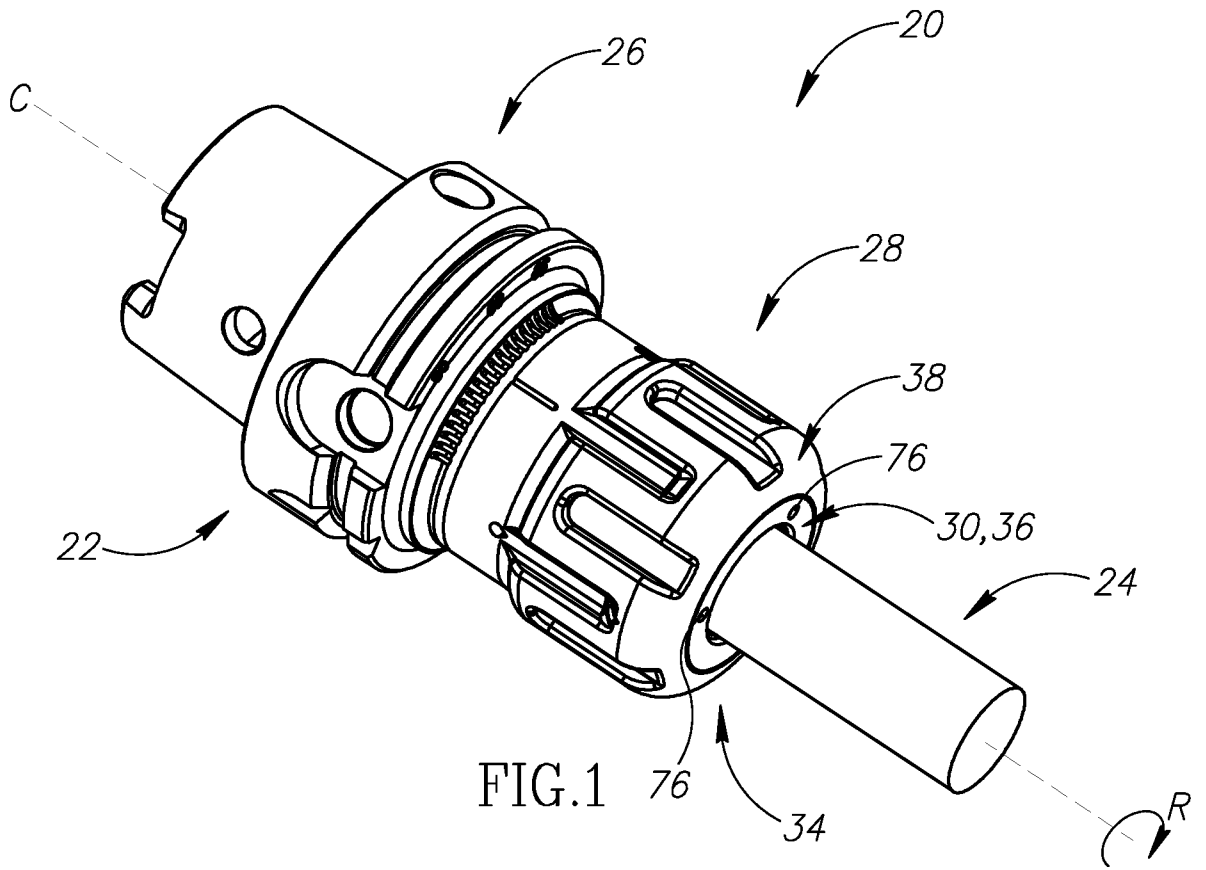

FIG. 1

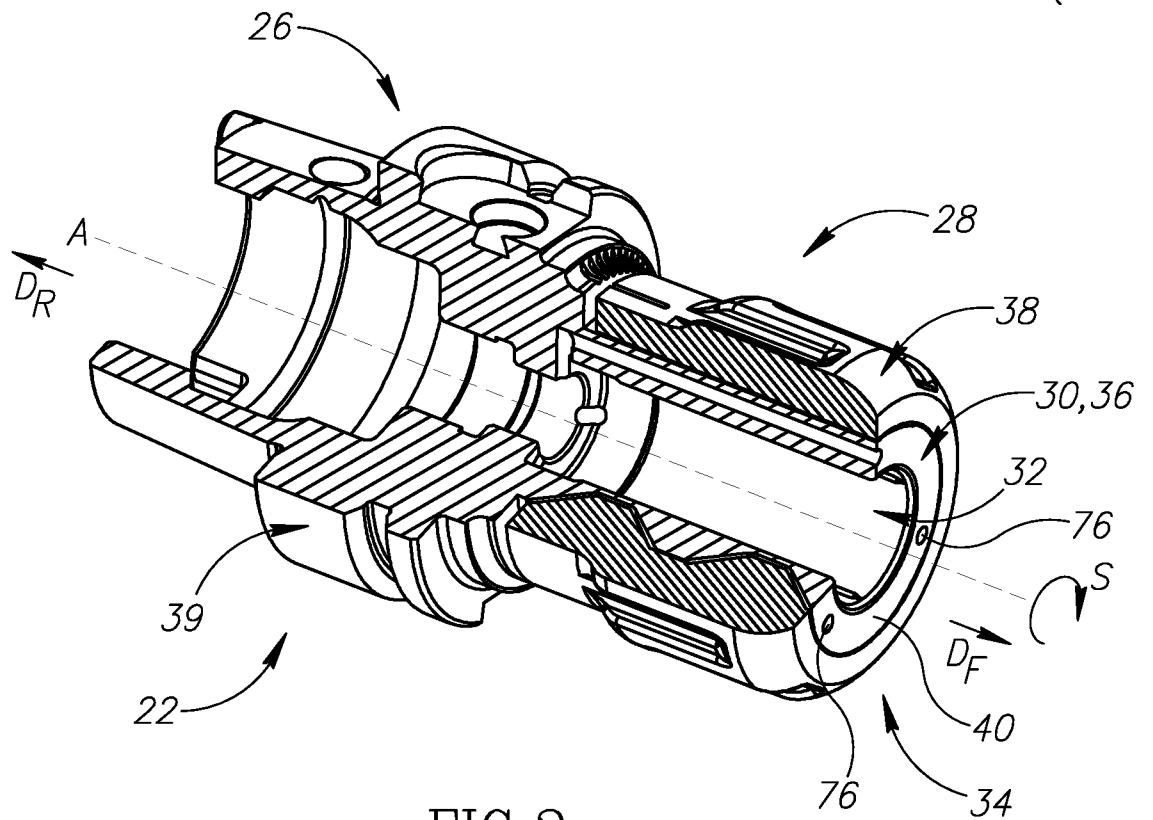

FIG. 2

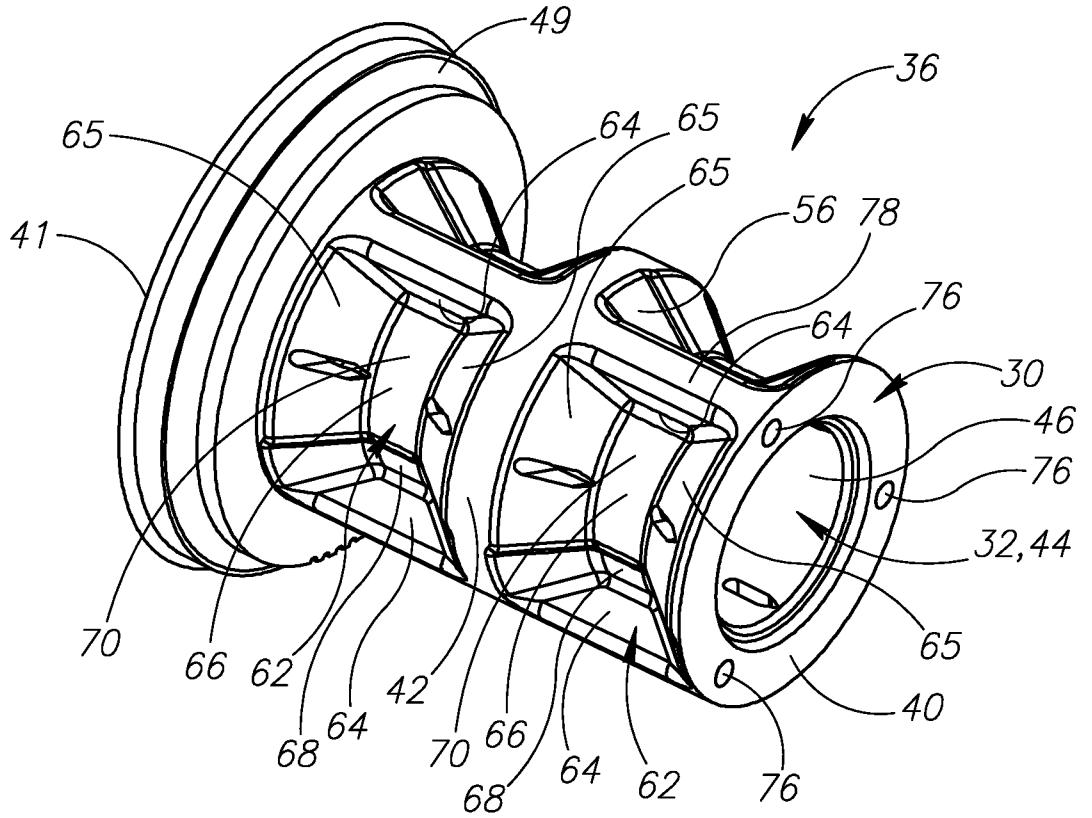

FIG. 3

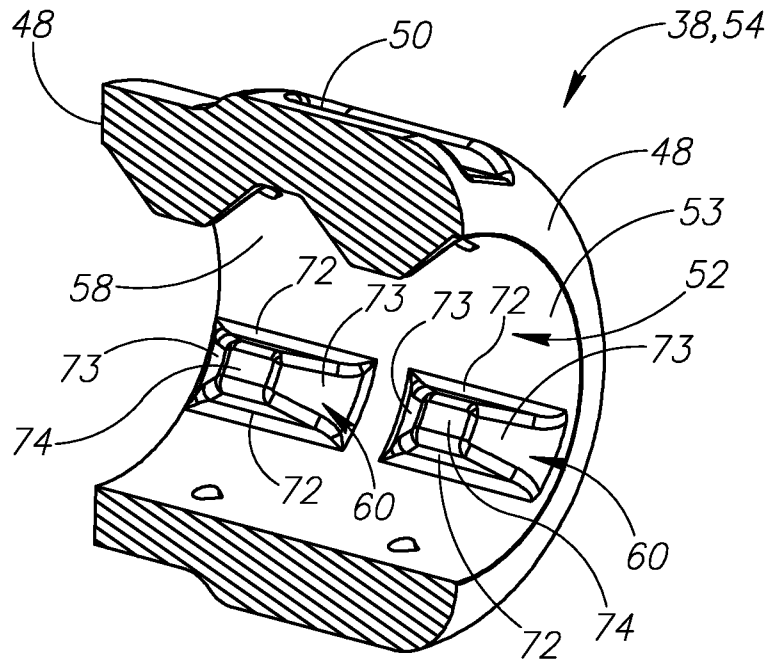

FIG. 4

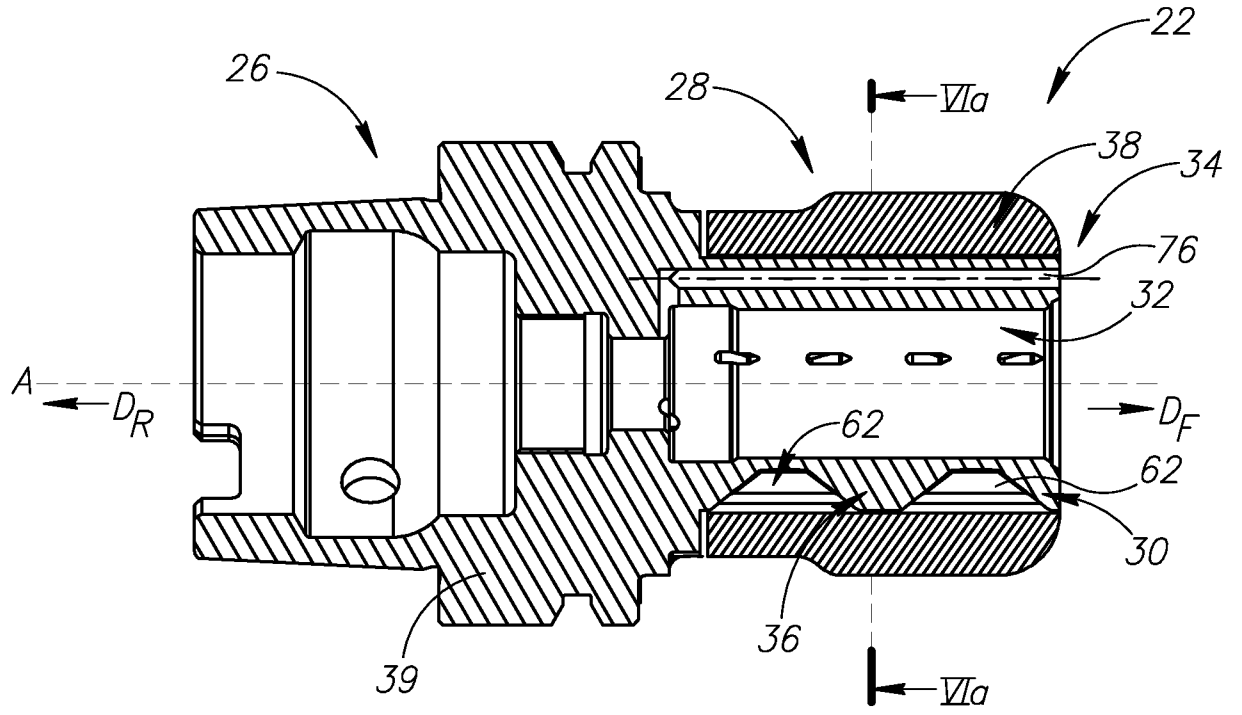

FIG. 5

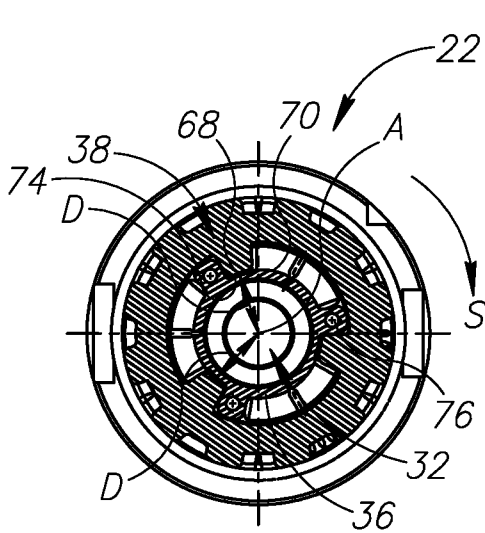

FIG. 6a

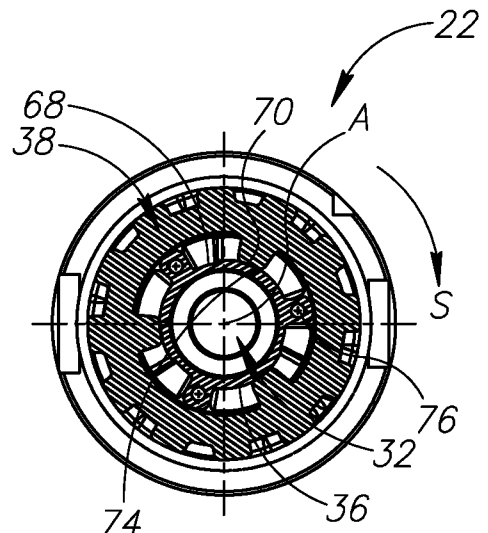

FIG. 6b

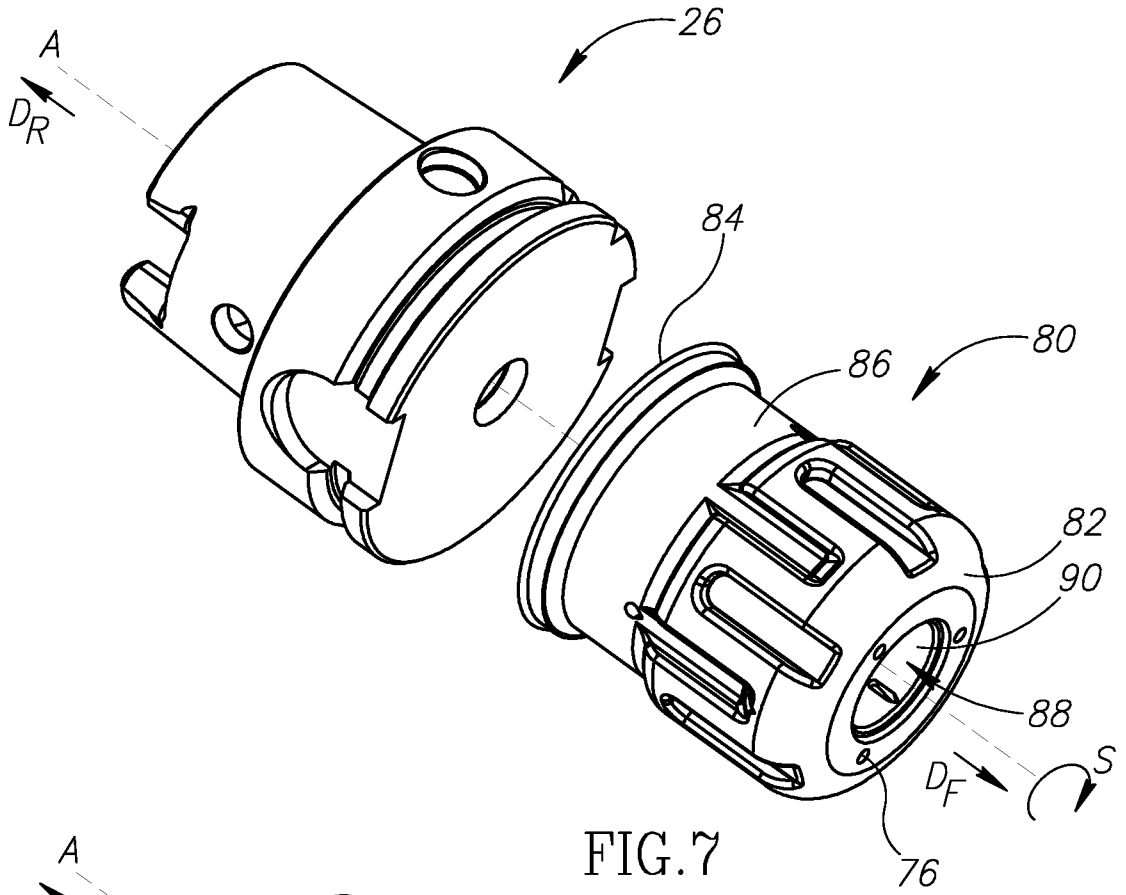

FIG. 7

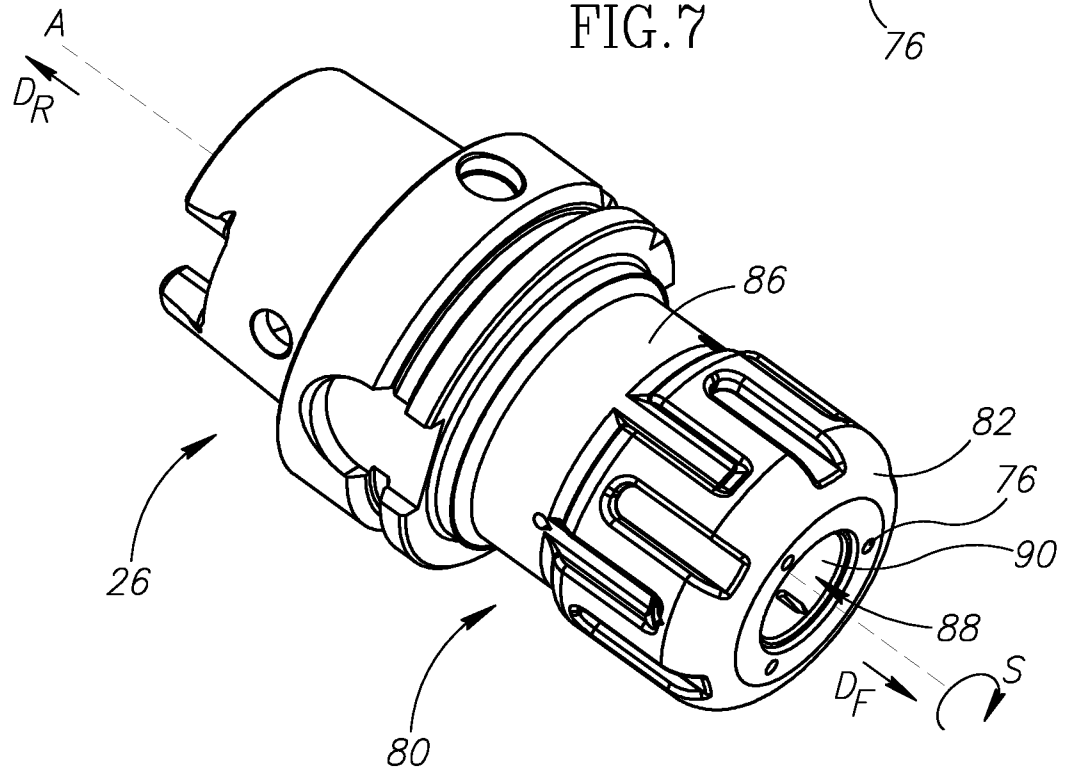

FIG. 8

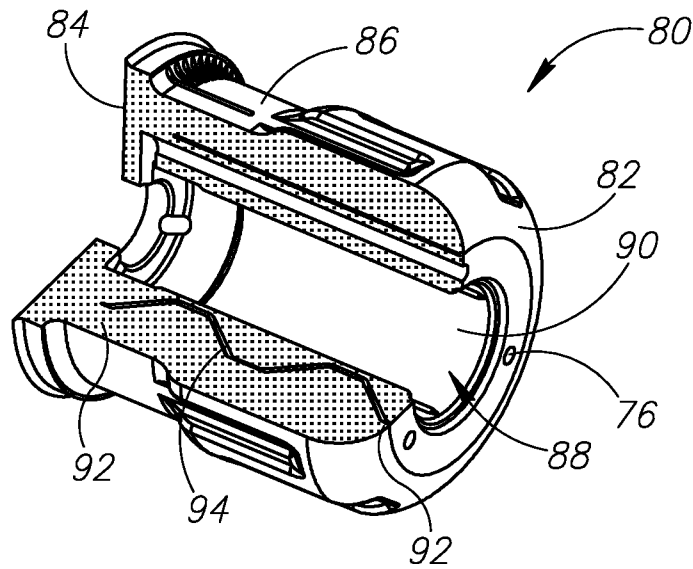

FIG. 9

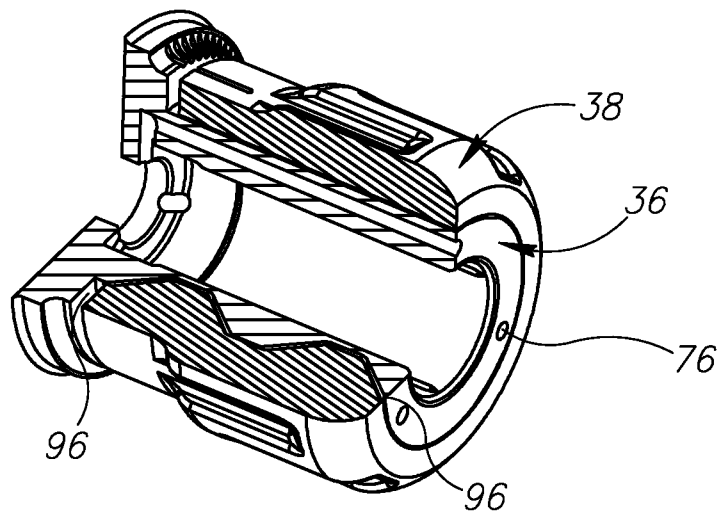
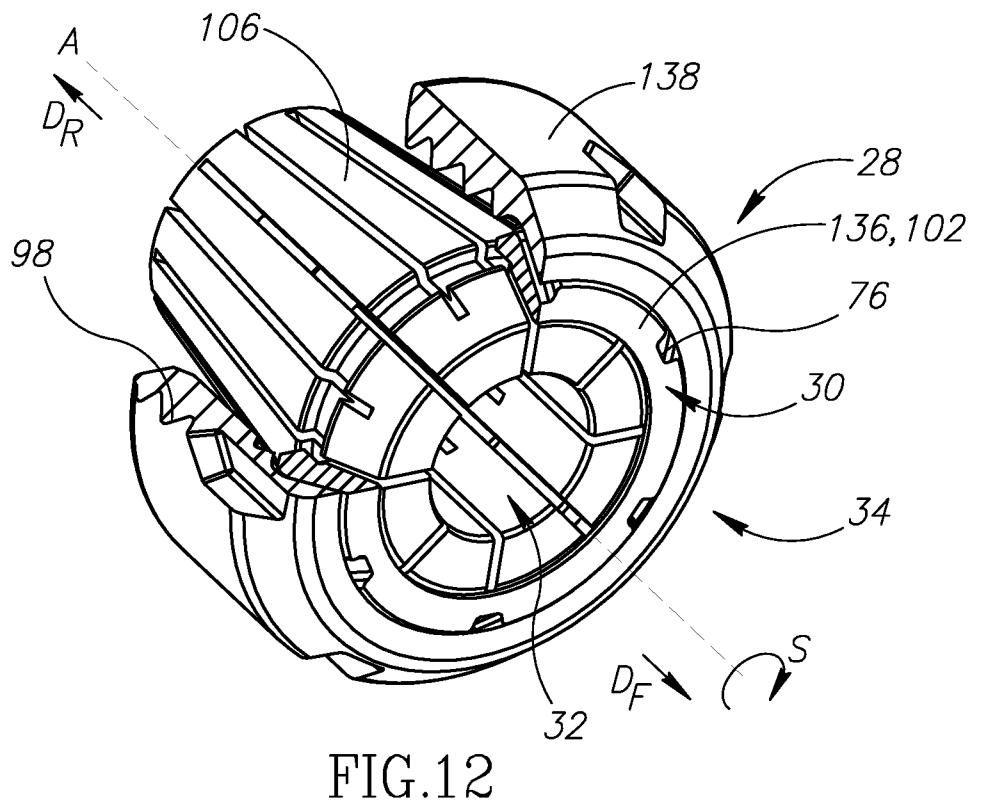
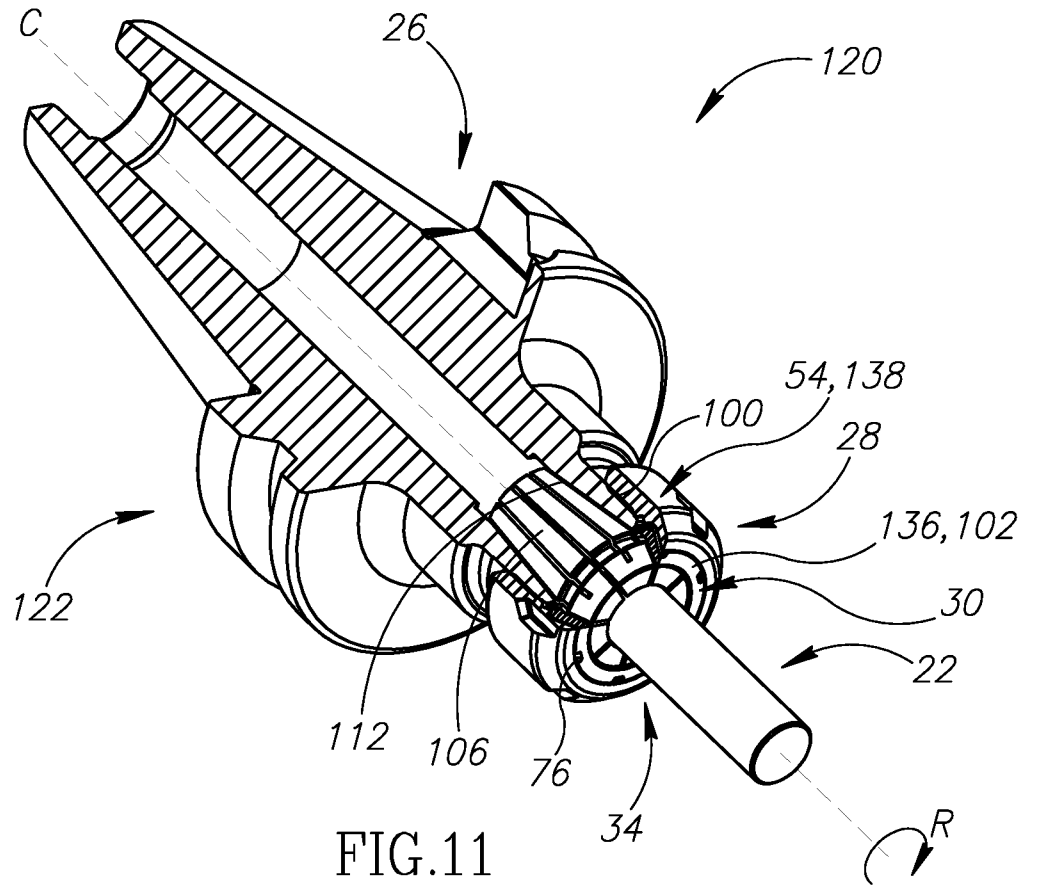

FIG. 10

6/9



7/9

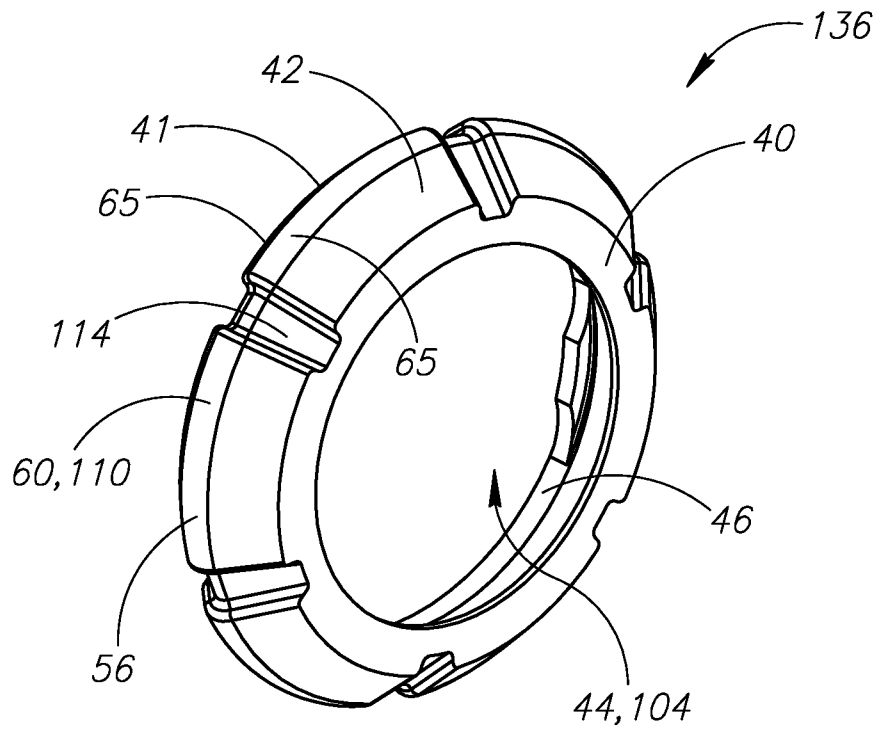

FIG. 13

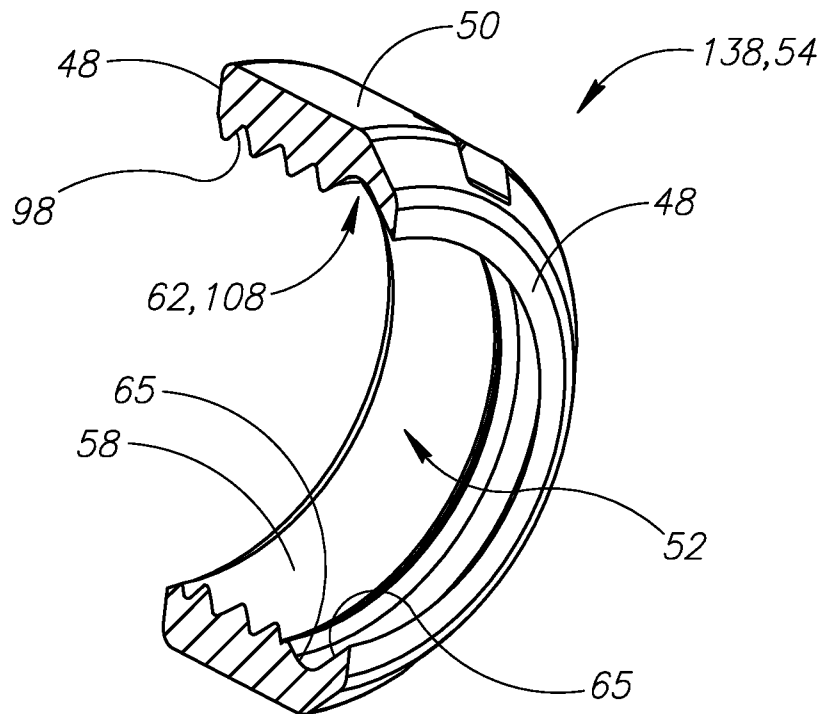

FIG. 14

8/9

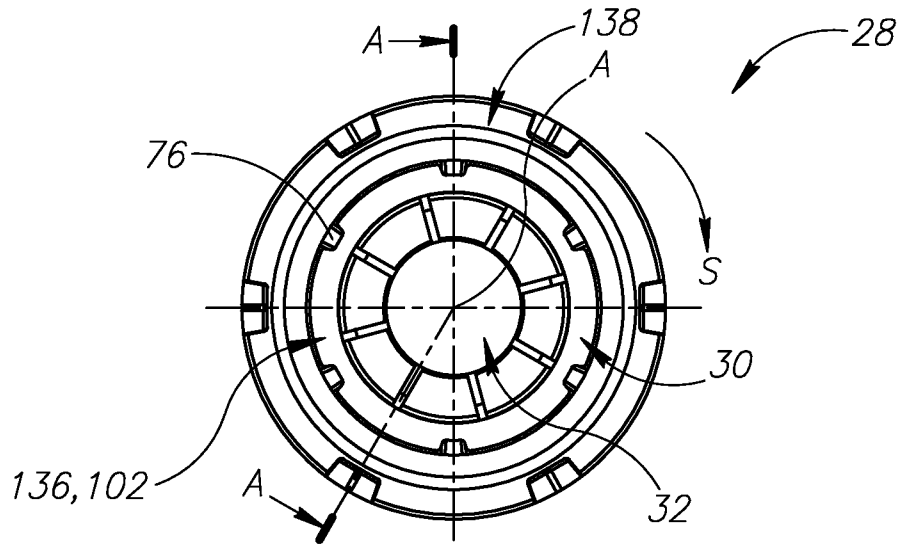

FIG. 15

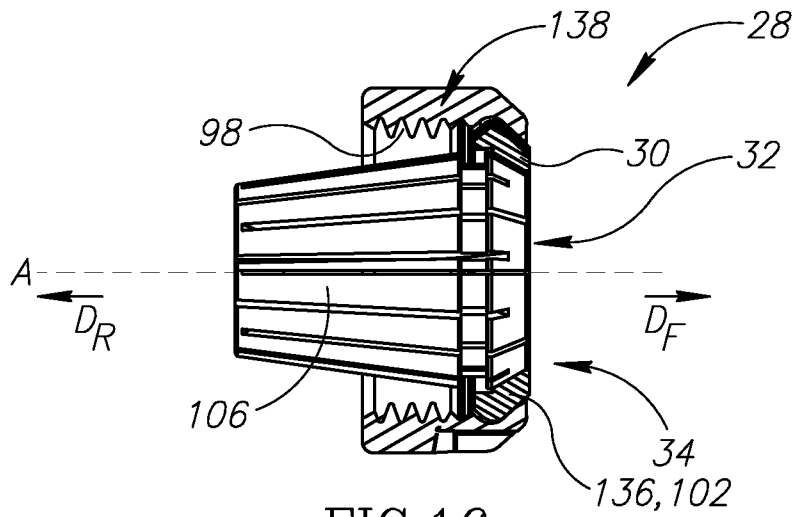

FIG. 16

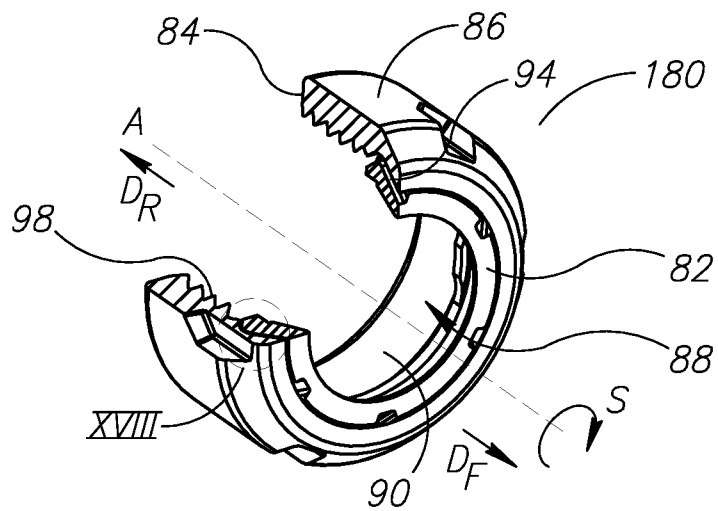

FIG. 17

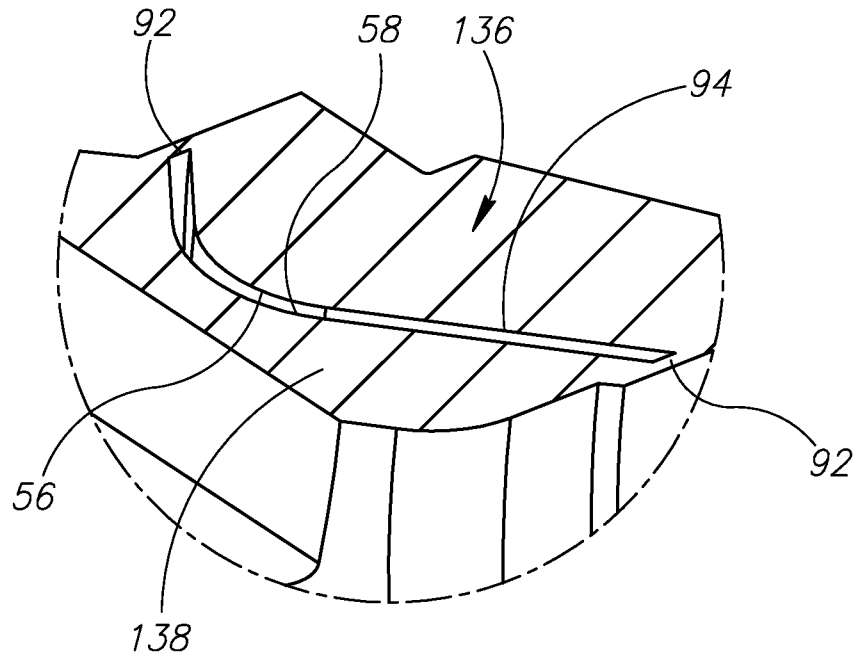

FIG.18

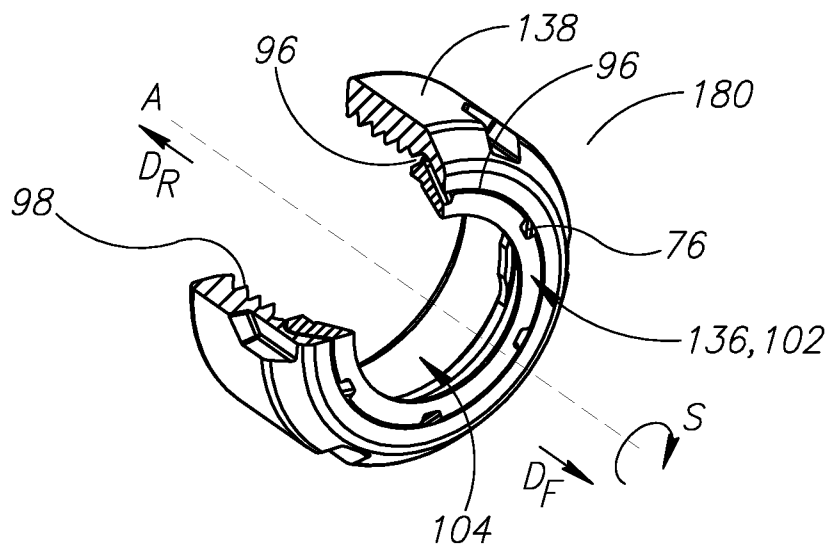

FIG.19

INTERNATIONAL SEARCH REPORT

International application No  
PCT/IL2018/050758

A. CLASSIFICATION OF SUBJECT MATTER  
INV. B23B31/117 B23B31/20  
ADD.  
According to International Patent Classification (IPC) or to both national classification and IPC

B. FIELDS SEARCHED  
Minimum documentation searched (classification system followed by classification symbols)  
B23B

Documentation searched other than minimum documentation to the extent that such documents are included in the fields searched

Electronic data base consulted during the international search (name of data base and, where practicable, search terms used)  
EPO-Internal, WPI Data

C. DOCUMENTS CONSIDERED TO BE RELEVANT

Category*	Citation of document, with indication, where appropriate, of the relevant passages	Relevant to claim No.
X	WO 2008/054295 A1 (ETP TRANSMISSION AB [SE]; ROSBERG NICLAS [SE]) 8 May 2008 (2008-05-08)	1,2,4,7, 11,13,20
A	the whole document	3,5,15, 21,22,24
A	----- JP S63 169205 A (NT TOOL KK) 13 July 1988 (1988-07-13)	1-7,11, 13, 15-18, 20-22, 24-32
A	----- US 2007/296162 A1 (GUY HANOCH [IL]) 27 December 2007 (2007-12-27) figures ----- -/--	1-7

Further documents are listed in the continuation of Box C.

See patent family annex.

\* Special categories of cited documents :

"A" document defining the general state of the art which is not considered to be of particular relevance

"E" earlier application or patent but published on or after the international filing date

"L" document which may throw doubts on priority claim(s) or which is cited to establish the publication date of another citation or other special reason (as specified)

"O" document referring to an oral disclosure, use, exhibition or other means

"P" document published prior to the international filing date but later than the priority date claimed

"T" later document published after the international filing date or priority date and not in conflict with the application but cited to understand the principle or theory underlying the invention

"X" document of particular relevance; the claimed invention cannot be considered novel or cannot be considered to involve an inventive step when the document is taken alone

"Y" document of particular relevance; the claimed invention cannot be considered to involve an inventive step when the document is combined with one or more other such documents, such combination being obvious to a person skilled in the art

"&" document member of the same patent family

Date of the actual completion of the international search  11 January 2019	Date of mailing of the international search report  18/01/2019
--	--

Name and mailing address of the ISA/ European Patent Office, P.B. 5818 Patentlaan 2 NL - 2280 HV Rijswijk Tel. (+31-70) 340-2040, Fax: (+31-70) 340-3016	Authorized officer  Rabolini, Marco
--	---

## INTERNATIONAL SEARCH REPORT

International application No  
PCT/IL2018/050758

C(Continuation). DOCUMENTS CONSIDERED TO BE RELEVANT		
Category*	Citation of document, with indication, where appropriate, of the relevant passages	Relevant to claim No.
A	<p>US 2003/132580 A1 (KOMINE TSUYOSHI [JP]) 17 July 2003 (2003-07-17)</p> <p>figures paragraph [0021] - paragraph [0022] paragraph [0027] - paragraph [0028] paragraph [0018] paragraph [0040] paragraph [0066] paragraph [0090] paragraph [0096] - paragraph [0097] -----</p>	<p>1,2, 8-10,12, 14,20,23</p>

# INTERNATIONAL SEARCH REPORT

International application No.  
PCT/IL2018/050758

## Box No. II Observations where certain claims were found unsearchable (Continuation of item 2 of first sheet)

This international search report has not been established in respect of certain claims under Article 17(2)(a) for the following reasons:

1.  Claims Nos.:  
because they relate to subject matter not required to be searched by this Authority, namely:
  
2.  Claims Nos.:  
because they relate to parts of the international application that do not comply with the prescribed requirements to such an extent that no meaningful international search can be carried out, specifically:
  
3.  Claims Nos.:  
because they are dependent claims and are not drafted in accordance with the second and third sentences of Rule 6.4(a).

## Box No. III Observations where unity of invention is lacking (Continuation of item 3 of first sheet)

This International Searching Authority found multiple inventions in this international application, as follows:

see additional sheet

1.  As all required additional search fees were timely paid by the applicant, this international search report covers all searchable claims.
  
2.  As all searchable claims could be searched without effort justifying an additional fees, this Authority did not invite payment of additional fees.
  
3.  As only some of the required additional search fees were timely paid by the applicant, this international search report covers only those claims for which fees were paid, specifically claims Nos.:
  
4.  No required additional search fees were timely paid by the applicant. Consequently, this international search report is restricted to the invention first mentioned in the claims; it is covered by claims Nos.:

### Remark on Protest

- The additional search fees were accompanied by the applicant's protest and, where applicable, the payment of a protest fee.
- The additional search fees were accompanied by the applicant's protest but the applicable protest fee was not paid within the time limit specified in the invitation.
- No protest accompanied the payment of additional search fees.

# INTERNATIONAL SEARCH REPORT

Information on patent family members

International application No

PCT/IL2018/050758

Patent document cited in search report	Publication date	Patent family member(s)	Publication date
WO 2008054295	A1	08-05-2008	NONE
-----			
JP S63169205	A	13-07-1988	JP 2562883 B2 11-12-1996
			JP S63169205 A 13-07-1988
-----			
US 2007296162	A1	27-12-2007	AT 528091 T 15-10-2011
			AU 2007264728 A1 03-01-2008
			BR PI0702924 A2 15-03-2011
			CA 2634170 A1 03-01-2008
			CN 101356033 A 28-01-2009
			EP 2032296 A1 11-03-2009
			IL 176592 A 17-05-2010
			JP 5015247 B2 29-08-2012
			JP 2009542445 A 03-12-2009
			KR 20090031844 A 30-03-2009
			RU 2008138747 A 10-08-2010
			TW 200812731 A 16-03-2008
			US 2007296162 A1 27-12-2007
			WO 2008001346 A1 03-01-2008
			ZA 200802595 B 28-10-2009
-----			
US 2003132580	A1	17-07-2003	CN 1432741 A 30-07-2003
			EP 1329272 A2 23-07-2003
			JP 2003205409 A 22-07-2003
			KR 20030061281 A 18-07-2003
			TW 536443 B 11-06-2003
			US 2003132580 A1 17-07-2003
-----			

**FURTHER INFORMATION CONTINUED FROM PCT/ISA/ 210**

This International Searching Authority found multiple (groups of) inventions in this international application, as follows:

1. claims: 1-7, 11, 13, 15-18, 20-22, 24-32

Chuck with sleeve wall portions that are pushed in radially  
---

2. claims: 8-10, 12, 14, 19, 23, 33

Chuck with collet  
---