

(No Model.)

J. B. SUTHERLAND.
STEAM ENGINE GOVERNOR.

No. 367,461.

Patented Aug. 2, 1887.

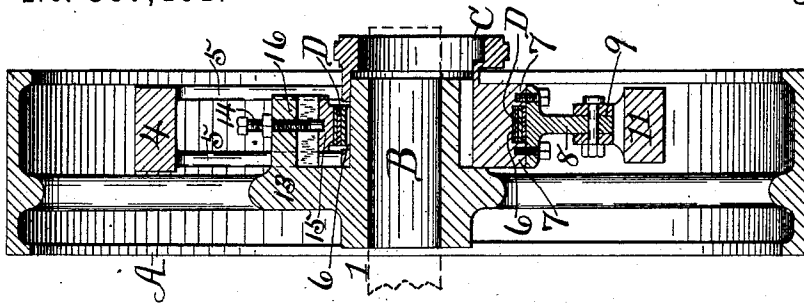

Fig. 3

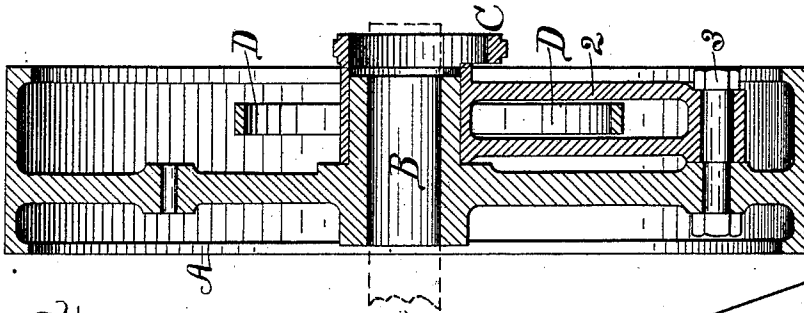

Fig. 2

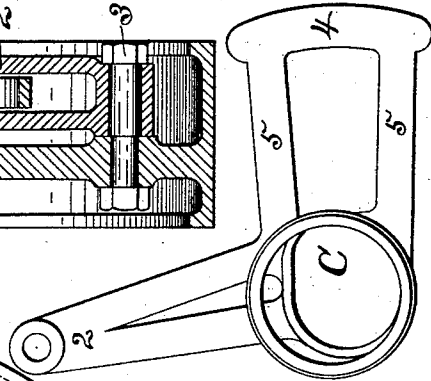

Fig. 4

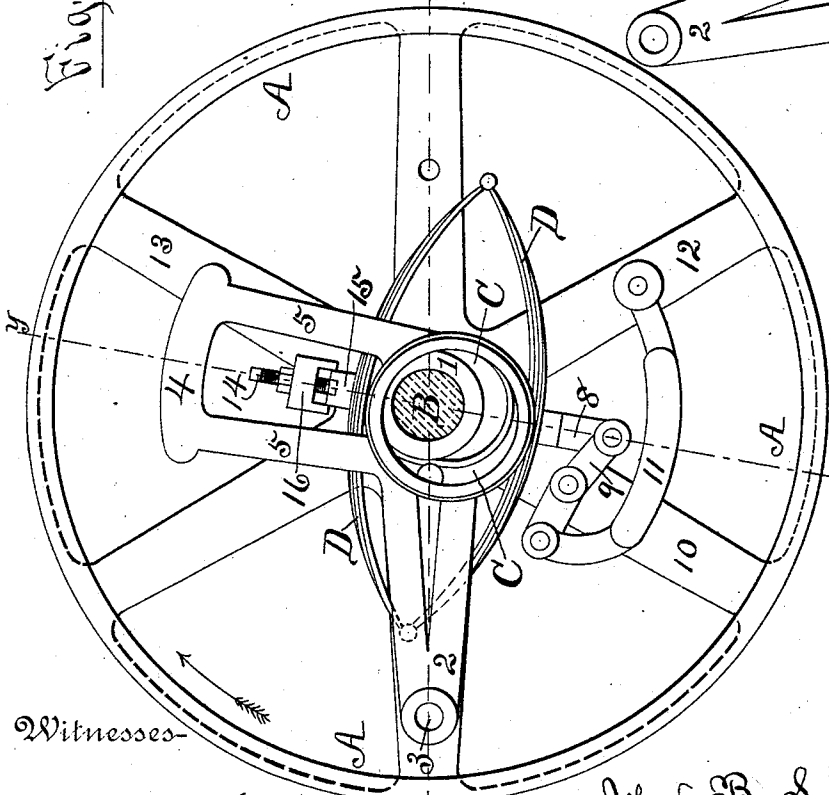

Fig. 1

Witnesses-

Henry Clark
Robert Miller

Inventor-

John B. Sutherland
By *His Attorney,*
Paul C. Raymond & Co.

UNITED STATES PATENT OFFICE.

JOHN B. SUTHERLAND, OF SYRACUSE, NEW YORK.

STEAM-ENGINE GOVERNOR.

SPECIFICATION forming part of Letters Patent No. 367,461, dated August 2, 1887.

Application filed February 17, 1887. Serial No. 227,899. (No model.)

To all whom it may concern:

Be it known that I, JOHN B. SUTHERLAND, of Syracuse, county of Onondaga, in the State of New York, a citizen of the United States, have invented certain new and useful Improvements in Steam-Engine Governors, of which the following is a specification, reference being had to the accompanying drawings, in which—

Figure 1 is a side elevation thereof; Fig. 2, a section taken on line *xx*, Fig. 1; Fig. 3, a section taken on line *yy*, Fig. 1, and Fig. 4 a detail of the eccentric, &c.

Similar letters and figures of reference indicate corresponding parts throughout the several views.

My invention relates to that class of governors in which weights (or balls) rotate with and around the main shaft; and it consists of an elliptic or arch spring provided on one side with a tension-regulator, which is connected to the governor-wheel, and the other side of which spring is connected to an eccentric upon the hub of the governor-wheel, the spring operating with the revolution of the main shaft in conjunction with counterbalance-weights, one being attached to the eccentric and the other to the governor-wheel, said weights being located substantially opposite each other, and the other novel features, hereinafter described and claimed.

It is constructed as follows: A is the governor-wheel, mounted in any desired manner upon the main shaft B, the wheel being provided with a hub, 1, elongated on one side, as shown.

C is an eccentric fitted to the hub 1 and provided with an arm, 2, by which it is secured to the wheel, a bolt, 3, being inserted through it and a spoke of the wheel and screwed up to a proper degree of tightness, or just enough to permit the proper play upon the bolt. Substantially at right angles to this arm I connect or secure the weight 4 to the eccentric by rods 5; or the eccentric-arm, two or more arms or rods, and weight may be all integral with each other.

Upon that side of the hub of the eccentric opposite adjacent to the weight 4, I cut a groove, 6, extending either partly or all of the way around the hub, creating the points or flanges 7, and upon these I secure the base

of the arm 8, across the groove 7, the arm projecting outward. To the outer end of this arm I connect pivotally one end of the angular lever 9, which is itself pivotally mounted upon a spoke, 10, of the governor-wheel, as shown; and to the other end of this angular lever I pivotally connect one end of the weight 11, the other end of which is pivotally mounted upon the spoke 12 of the governor-wheel, so that by the movement of the eccentric this weight is alternately drawn in from and thrown out toward the periphery of the governor-wheel.

Upon the opposite side from the arm 8, and projecting horizontally from the spoke 13, is a stud or block, 16, through which I insert vertically a set-screw, 14, the point of which bears either against the spring D or against a plate, 15, interposed between the set-screw and the spring.

The spring D is an ordinary elliptic or arch spring, the sides of which lie in the groove 6 in the hub of the eccentric, being held adjustably on one side by the set-screw 14, by which the tension of the spring is regulated, and being held securely on the opposite side by the base of the arm 8, as shown in Fig. 3 of the drawings.

It will be observed that any variation in the tension of the spring by the set-screw 14 will correspondingly or proportionally vary the speed of the engine; also, as one of the weights is a part of the eccentric, the friction is correspondingly reduced as well as the number of parts.

Having described my invention, what I claim as new, and desire to secure by Letters Patent, is—

1. In a governor, the combination of an eccentric mounted upon the main shaft and having its hub provided with a peripheral groove with an elliptic spring fitting in said groove and operating together, substantially as described.

2. In a governor, a main shaft, an eccentric provided at its hub with a peripheral groove, and an elliptic spring mounted in said groove and encompassing the shaft and eccentric, substantially as described.

3. In a governor, a main shaft, an eccentric having a grooved hub, and an elliptic spring,

both sides of which are seated in the periphery of the eccentric hub, substantially as described.

4. In a governor, a main shaft, an eccentric actuated by the main shaft, an elliptic spring seated in the groove of the eccentric hub, the wheel, and a spring-tension adjuster mounted upon a spoke of the wheel, substantially as described.

5. In a governor, a main shaft, an eccentric having a grooved hub, and a spring seated in said groove and fitting with adjustable contact against a plate interposed between it and a set-screw, substantially as described.

6. The combination of a wheel, a shaft, a grooved hubbed eccentric actuated thereby, an elliptic spring seated in the groove of the hub and thus fitting upon the eccentric, an arm, 8, connected to the eccentric, and a crank pivoted upon a spoke of the wheel and connected to said arm and to a counterbalance-weight, substantially as described.

7. In a governor, an adjusting-block secured to the wheel and provided with a set-screw, in combination with the spring, substantially as described.

8. In a governor, a weight, 4, rigidly secured to the eccentric by means of two or more arms or rods, 5, arranged opposite each other, as shown, an elliptic spring passing longitudinally between said arms, and an arm, 2, integral with the eccentric and formed at a substantial right angle to the weight-supporting arms or rods 5, and suitably secured at its free end to a spoke of the wheel, substantially as shown and described.

In witness whereof I have hereunto set my hand this 1st day of February, 1887.

JOHN B. SUTHERLAND.

In presence of—

WM. C. RAYMOND,
HIRAM CLARK.