



## INTERNATIONAL APPLICATION PUBLISHED UNDER THE PATENT COOPERATION TREATY (PCT)

<p>(51) International Patent Classification <sup>5</sup> : <b>B60K 15/04</b></p>	<p><b>A1</b></p>	<p>(11) International Publication Number: <b>WO 91/11342</b> (43) International Publication Date: 8 August 1991 (08.08.91)</p>
<p>(21) International Application Number: PCT/SE91/00011 (22) International Filing Date: 8 January 1991 (08.01.91) (30) Priority data: 9000277-5 26 January 1990 (26.01.90) SE (71) Applicant (for all designated States except US): AB VOLVO [SE/SE]; S-405 08 Göteborg (SE). (72) Inventor; and (75) Inventor/Applicant (for US only) : HARDE, Bo [SE/SE]; Tubogatan 10A, S-417 21 Göteborg (SE). (74) Agent: AWAPATENT AB; Box 53252, S-400 16 Göteborg (SE).</p>		<p>(81) Designated States: AT, AT (European patent), AU, BB, BE (European patent), BF (OAPI patent), BG, BJ (OAPI patent), BR, CA, CF (OAPI patent), CG (OAPI patent), CH, CH (European patent), CM (OAPI patent), DE, DE (European patent), DK, DK (European patent), ES, ES (European patent), FI, FR (European patent), GA (OAPI patent), GB, GB (European patent), GR (European patent), HU, IT (European patent), JP, KP, KR, LK, LU, LU (European patent), MC, MG, ML (OAPI patent), MR (OAPI patent), MW, NL, NL (European patent), NO, PL, RO, SD, SE, SE (European patent), SN (OAPI patent), SU, TD (OAPI patent), TG (OAPI patent), US.</p> <p><b>Published</b> With international search report. In English translation (filed in Swedish).</p>
<p>(54) Title: A DEVICE IN FUEL TANKS</p> <div data-bbox="564 1227 1230 1787" data-label="Image"> </div> <p>(57) Abstract</p> <p>The invention concerns a device in fuel tanks (1), preferably for vehicles, said tanks being provided with a mouth socket (2) to which a filler tube (3) is connected so as to have its one end portion projecting into the tank (1). Between the mouth socket (2) and the filler tube (3) a seal (4) is provided, the latter being formed with a portion (5) grippingly enclosing the mouth edge (6) of the socket (2) and defining, together with the filler tube (3), an intermediate space (13) allowing oscillation of the filler tube (3) relatively to the socket (2). A washer (14) is pressed against the filler tube (3) and is formed with a bent-over portion (15) grippingly engaging said portion (5) of the seal (4). A reinforcement sleeve (17) is positioned inside the filler tube (3) and presses against the inner face of the filler tube (3). A clamp-joint sleeve (16) is fitted around the mouth socket (2), enclosing portion (5) of the seal (4) and the washer (14).</p>		

**FOR THE PURPOSES OF INFORMATION ONLY**

Codes used to identify States party to the PCT on the front pages of pamphlets publishing international applications under the PCT.

AT	Austria	ES	Spain	MG	Madagascar
AU	Australia	FI	Finland	ML	Mali
BB	Barbados	FR	France	MN	Mongolia
BE	Belgium	GA	Gabon	MR	Mauritania
BF	Burkina Faso	GB	United Kingdom	MW	Malawi
BG	Bulgaria	GN	Guinea	NL	Netherlands
BJ	Benin	GR	Greece	NO	Norway
BR	Brazil	HU	Hungary	PL	Poland
CA	Canada	IT	Italy	RO	Romania
CF	Central African Republic	JP	Japan	SD	Sudan
CG	Congo	KP	Democratic People's Republic of Korea	SE	Sweden
CH	Switzerland	KR	Republic of Korea	SN	Senegal
CI	Côte d'Ivoire	LI	Liechtenstein	SU	Soviet Union
CM	Cameroon	LK	Sri Lanka	TD	Chad
CS	Czechoslovakia	LU	Luxembourg	TG	Togo
DE	Germany	MC	Monaco	US	United States of America
DK	Denmark				

A DEVICE IN FUEL TANKS

The invention concerns a device in fuel tanks, preferably for vehicles, the tank being provided with a mouth socket to which a filler tube is connected.

Previously, fuel tanks for vehicles within the car industry were made from deep-drawn, lead-covered sheet metal. In accordance with prior-art technology, an upper and a lower section are welded together and the tank thus formed is provided with a socket to which a filler tube is in turn connected. In order to prevent leakages from arising at the socket mouth, as may be caused by vibrations when the vehicle is running, a rubber hose is inserted between the socket and the filler tube and attached to said components with the aid of hose clamps. In particularly exposed positions reinforced rubber hoses are usually used.

In later years, synthetic resin tanks have come into use as they are now capable of satisfying the strength and security requirements on fuel tanks. However, the technology used in the manufacture of sheet metal tanks as concerns the interconnection between the socket and the filler tube has been adopted also for synthetic resin tanks. Thus, the socket, now manufactured from blow-moulded synthetic resin, is connected to the filler tube by means of a rubber hose and hose clamps. The joint between the tank and the filler tube is, however, a weak link. The rubber hose ages more rapidly than the rest of the components, particularly when used in positions where, during vehicle running it is exposed to sprays of water mixed with sand and salt from the roadway. This increases largely the risks for leakages caused by cracks in the tube, and also increases the risks for rupture of the tube, which could easily occur in the event of a collision. Obviously, fuel leakages constitute serious fire hazards.

The invention provides a device designed for direct connection of a rigid filler tube to a filler tank without the need of a hose. The device allows rotational and to some extent oscillating movements of the filler tube  
5 relatively to the fuel tank and even distortion of the fuel tank without any risk of leakage. The characterizing features of this device appears from the appended claims.

The invention will be described in closer detail in the following with reference to the accompanying drawing,  
10 wherein:

FIG. 1 is a longitudinal sectional view through the connection area between a fuel tank and a filler tube; and

FIG. 2 is a longitudinal section through a seal incorporated into the device.

15 On the drawing only a small part of the fuel tank 1 is illustrated, the filler opening of which merges into a mouth socket 2. A filler tube 3 extends through the mouth socket 2 and projects somewhat into the tank 1.

In accordance with the invention a seal 4, having the  
20 particular configuration appearing from Fig. 2, is inserted between the mouth socket 2 and the filler tube 3. A first portion 5 of the seal 4 grippingly encloses the mouth edge 6 of the socket 2 while a second portion 7 and a third portion 8 of the seal are pressed against the  
25 socket 2 and the filler tube 3, respectively, in a manner similar to that of O-rings. By means of a fourth portion 9 the seal 4 together with the filler tube 3 projects into the interior of the tank 1 and the inner marginal end portion 10 of the seal likewise presses against the filler  
30 tube 3 in the manner of an O-ring. The seal 4 is also formed with a lip portion 11 which abuts the inner face of the mouth socket 2 in the area of the junction of said socket with the tank 1. Together with the seal portion 9 the lip 11 forms a pocket 12.

35 In the area of the gripping portion 5 the seal 4 is configured so as to define a space 13 towards the filler tube 3. In accordance with the invention, a washer 14 is

3

forced onto the filler tube 3 so as to press against the latter and an outer, bent-over portion 15 of the washer 14 bridges said space 13 and grippingly engages the portion 5 of the seal 4. A clamp-joint sleeve 16 is provided around the mouth socket 2 so as to enclose portion 5 of the seal 4 and the washer 14. In its function as an interconnecting member the clamp-joint sleeve 16 serves as security device in the event of collisions.

Owing to the design of the seal 4 as described above and the position of the seal in the mouth of the tank 1 the tank 1 is well sealed while at the same time some movement of the filler tube 3 is allowed in an arbitrary direction in relation to the mouth socket 2 without any risks of leakage. When the filler tube 3 swings arbitrarily to the left or to the right as seen in the drawing figure the space 13 will be reduced or increased accordingly on one side or the other as the case may be while at the same time the washer 14 will enclose portion 5 of the seal 4 to a larger or smaller extent. The marginal end portion 10 of the seal 4 will at all times adhere to the inner end portion of the filler tube 3 and sealingly abut against the latter.

Owing to the particular design of the seal 4 the filler tube may be manufactured from a rigid material, such as aluminium, which is better suited than a rubber hose to withstand the effects of exposure to the severe conditions prevailing in a vehicle. In accordance with the invention, the inner end portion of the filler tube 3 is also provided with a reinforcement sleeve 17 made from a harder material than the filler tube 3. The sleeve 17 permits a certain maximum movement of the filler tube 3 without the latter being distorted, which otherwise could have caused leakages.

In case the tank 1 is distorted, for instance in the event of a collision, resulting in generation of a positive pressure is created inside the tank, said positive pressure will force the lip 11 of the seal to be pressed

4

against the inner faces of the socket 2 or the tank 1 while at the same time the portion 9 and the edge portion 10 of the seal will be pressed against the filler tube 3. Positive pressure inside the pocket 12 thus will provide  
5 an improved sealing function.

The invention is not limited to the embodiment as illustrated and described but could be varied in many ways within the scope of the appended claims. It goes without saying that the seal 4 could be used in various kinds of  
10 tanks in other connections than in fuel tanks for vehicles.

15

20

25

30

35

## CLAIMS

1. A device in fuel tanks having a mouth socket (2) with a filler tube (3) connected thereto, characterized in that one of the end portions of the filler tube (3) extends through the mouth socket (2) and into the tank (1), that a seal (4) is provided between the mouth socket (2) and the filler tube (3), a portion (5) of said seal enclosing the outer mouth edge (6) of the socket (2) so as to define a space (13) together with said filler tube (3), thus permitting oscillating movements of said filler tube (3) relatively to the socket (2), that a washer (14) is pressed into abutment against the filler tube (3), said washer (14) being formed with a bent-over portion (15) which is fitted over said seal portion (5), that inside the filler tube (3) is positioned a reinforcement sleeve (17) which is pressed into engagement with the inner wall of the filler tube (3), and that a clamp-joint sleeve (16) is fitted externally about the mouth socket (2) so as to enclose the gripping bent-over portion (15) of the seal (4) as well as the washer (14).

2. A device as claimed in claim 1, characterized in that the seal (4) has a lip (11) which is directed inwards, towards the tank (1), and which is in abutting relationship with the inner face of the mouth socket (2) or the tank (1), said lip (11) defining a pocket (12) together with the rest of the seal (4).

3. A device as claimed in claim 1, characterized in that the inner edge end portion (10) of the seal (4) serves the purpose of an O-ring.

Fig.1

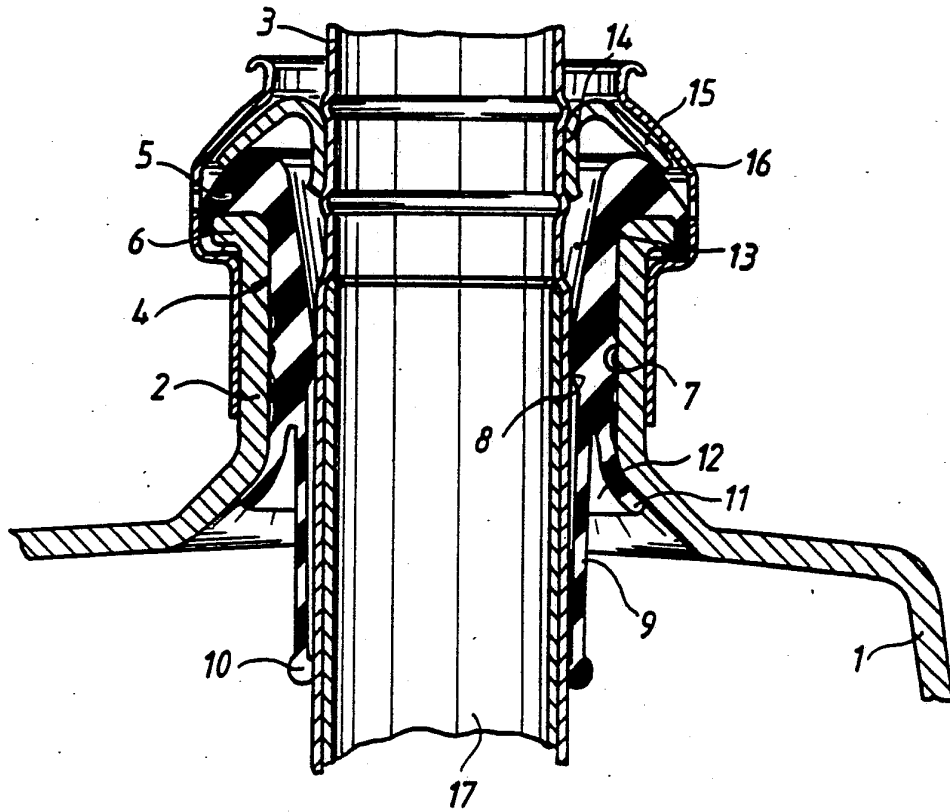
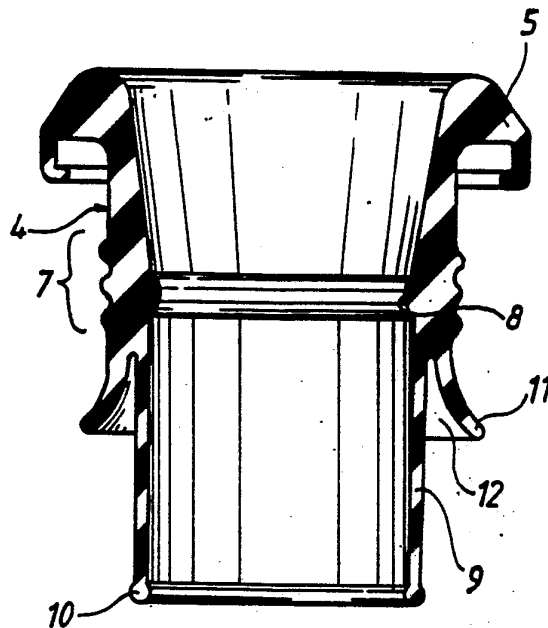

Fig.2



# INTERNATIONAL SEARCH REPORT

International Application No PCT/SE 91/00011

<b>I. CLASSIFICATION OF SUBJECT MATTER</b> (if several classification symbols apply, indicate all) <sup>6</sup>		
According to International Patent Classification (IPC) or to both National Classification and IPC		
IPC5: B 60 K 15/04		
<b>II. FIELDS SEARCHED</b>		
Minimum Documentation Searched <sup>7</sup>		
Classification System	Classification Symbols	
IPC5	B 60 K	
Documentation Searched other than Minimum Documentation to the Extent that such Documents are Included in Fields Searched <sup>8</sup>		
SE,DK,FI,NO classes as above		
<b>III. DOCUMENTS CONSIDERED TO BE RELEVANT<sup>9</sup></b>		
Category *	Citation of Document, <sup>11</sup> with indication, where appropriate, of the relevant passages <sup>12</sup>	Relevant to Claim No. <sup>13</sup>
A	US, A, 4088241 (HALL ET AL) 9 May 1978, see the whole document  -----  -----	1
<p>* Special categories of cited documents:<sup>10</sup></p> <p>"A" document defining the general state of the art which is not considered to be of particular relevance</p> <p>"E" earlier document but published on or after the international filing date</p> <p>"L" document which may throw doubts on priority claim(s) or which is cited to establish the publication date of another citation or other special reason (as specified)</p> <p>"O" document referring to an oral disclosure, use, exhibition or other means</p> <p>"P" document published prior to the international filing date but later than the priority date claimed</p> <p>"T" later document published after the international filing date or priority date and not in conflict with the application but cited to understand the principle or theory underlying the invention</p> <p>"X" document of particular relevance, the claimed invention cannot be considered novel or cannot be considered to involve an inventive step</p> <p>"Y" document of particular relevance, the claimed invention cannot be considered to involve an inventive step when the document is combined with one or more other such documents, such combination being obvious to a person skilled in the art.</p> <p>"&amp;" document member of the same patent family</p>		
<b>IV. CERTIFICATION</b>		
Date of the Actual Completion of the International Search		Date of Mailing of this International Search Report
19th April 1991		1991 -04- 4
International Searching Authority		Signature of Authorized Officer
SWEDISH PATENT OFFICE		Göran Carlström

**ANNEX TO THE INTERNATIONAL SEARCH REPORT  
ON INTERNATIONAL PATENT APPLICATION NO.PCT/SE 91/00011**

This annex lists the patent family members relating to the patent documents cited in the above-mentioned international search report. The members are as contained in the Swedish Patent Office EDP file on **91-03-23**. The Swedish Patent Office is in no way liable for these particulars which are merely given for the purpose of information.

Patent document cited in search report	Publication date	Patent family member(s)	Publication date
US-A- 4088241	78-05-09	NONE	